



US00D902962S

(12) **United States Design Patent**
Juarez

(10) **Patent No.: US D902,962 S**

(45) **Date of Patent: ** *Nov. 24, 2020**

(54) **APPARATUS FOR REMOVING AND MELTING SNOW**

(71) Applicant: **Robert Juarez**, San Antonio, TX (US)

(72) Inventor: **Robert Juarez**, San Antonio, TX (US)

(*) Notice: This patent is subject to a terminal disclaimer.

(**) Term: **15 Years**

(21) Appl. No.: **29/620,749**

(22) Filed: **May 22, 2017**

(51) **LOC (12) Cl.** **15-03**

(52) **U.S. Cl.**
USPC **D15/11**

(58) **Field of Classification Search**
USPC D15/10-12, 28, 32, 33
CPC E01H 5/00; E01H 5/106; E01H 5/108;
E01H 5/12; E01H 5/10; E01H 5/102;
E01H 5/104; E01H 6/00

See application file for complete search history.

(56) **References Cited**

U.S. PATENT DOCUMENTS

- 2,078,310 A * 4/1937 Berres E01H 5/07
37/248
- 3,304,632 A * 2/1967 Joseph E01H 5/104
37/228
- 3,309,798 A * 3/1967 Devlin E01H 5/104
37/228
- 3,404,470 A * 10/1968 Raiti E01H 5/098
37/228
- 4,071,966 A * 2/1978 Cohen E01H 5/098
193/31 A
- D253,174 S * 10/1979 Mason D15/12

- 4,249,322 A * 2/1981 McLaughlin E01H 5/106
37/196
- 4,885,852 A * 12/1989 Gudmundsson E01H 5/076
37/260
- 5,588,231 A * 12/1996 Mavrianos E01H 5/104
126/343.5 R
- 5,642,673 A * 7/1997 Lucky, Sr. B60F 1/043
104/279
- D384,082 S * 9/1997 Lucky, Sr. D15/10
- 5,956,872 A * 9/1999 Mavrianos E01H 5/104
126/343.5 R
- D450,715 S * 11/2001 Adams D15/12
- 6,553,693 B1 * 4/2003 Desmarais B61D 15/00
104/279

* cited by examiner

Primary Examiner — Mark A Goodwin

(74) *Attorney, Agent, or Firm* — Paul R. Martin

(57) **CLAIM**

The ornamental design for an apparatus for removing and melting snow, as shown and described.

DESCRIPTION

FIG. 1 is a perspective view of apparatus for removing and melting snow of my new design showing it connected to a truck cab and chassis.

FIG. 2. Is another perspective view thereof.

FIG. 3 is an elevational view of the left side thereof.

FIG. 4 is an elevational view of the right side thereof.

FIG. 5 is a front elevational view thereof.

FIG. 6 is a back elevational view thereof; and,

FIG. 7 is a top plan view thereof.

The broken line showing of the truck cab in FIG. 1 is included for the purpose of illustrating environmental structure only and forms no part of the claimed design.

1 Claim, 6 Drawing Sheets

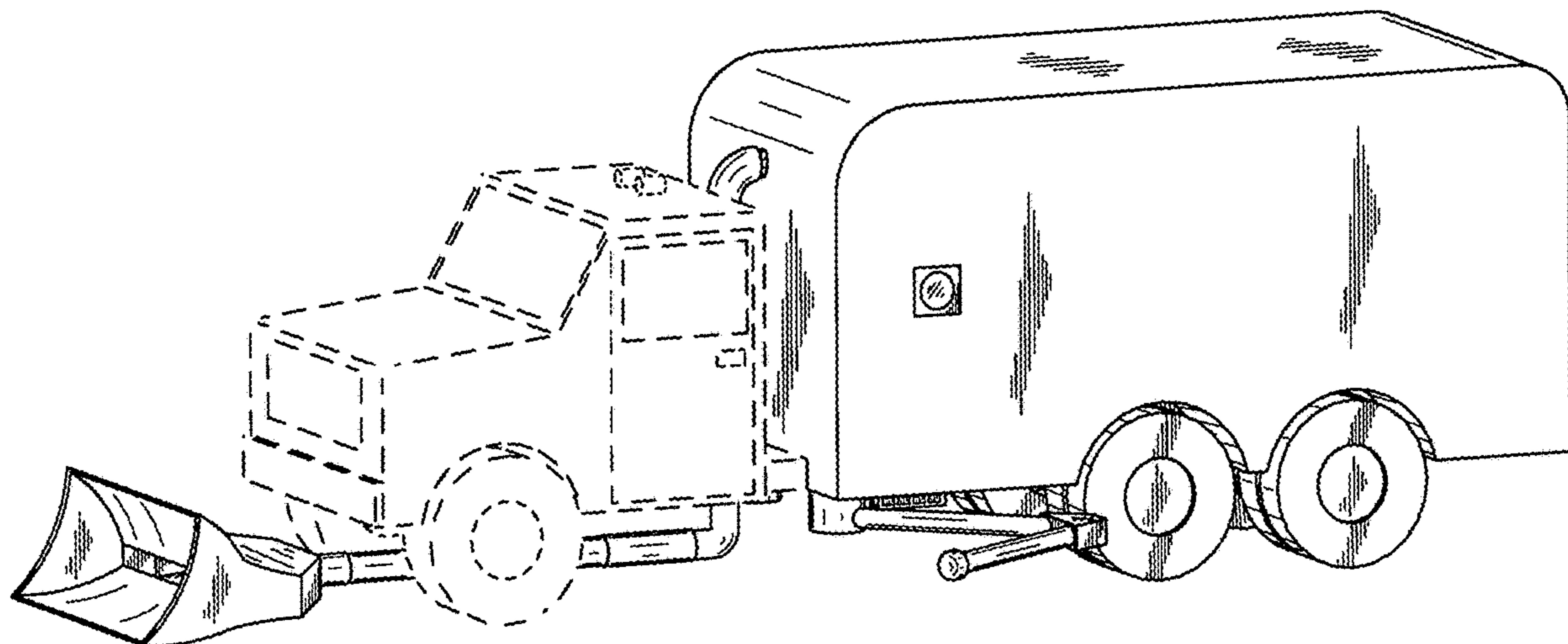

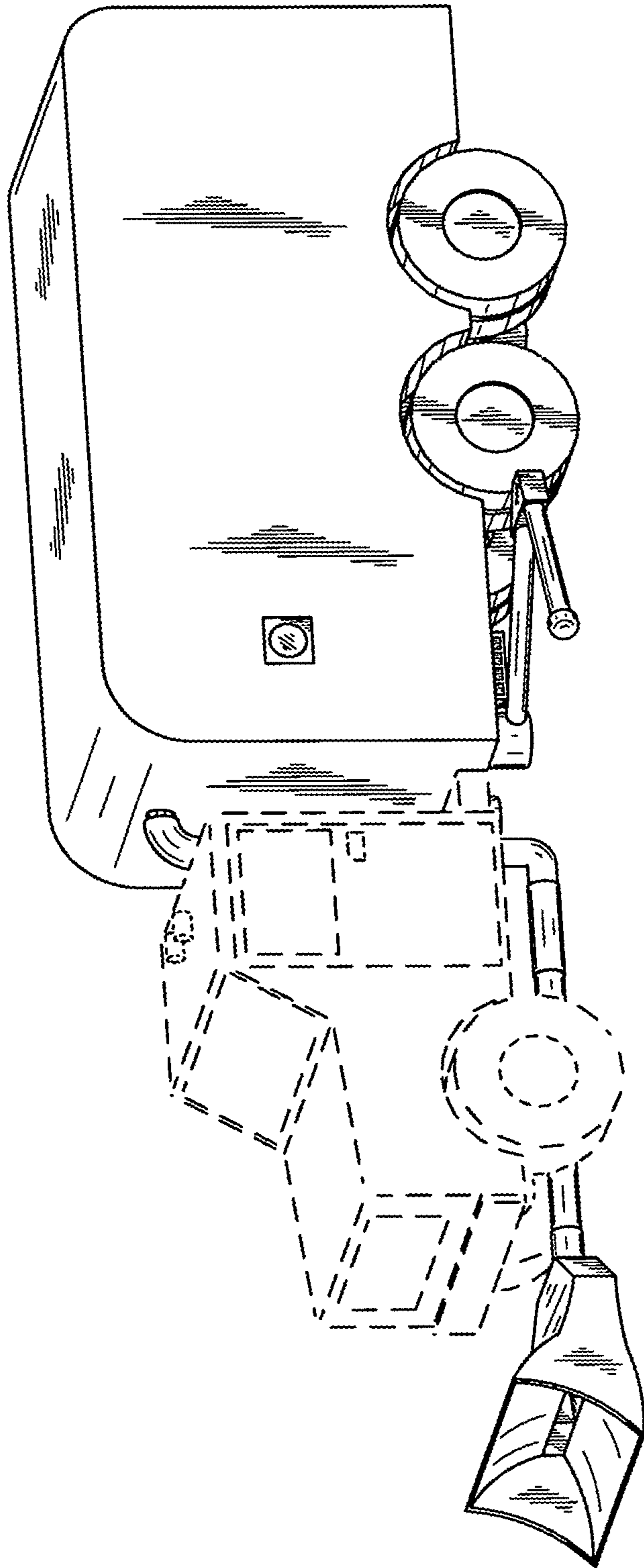

FIG. 1

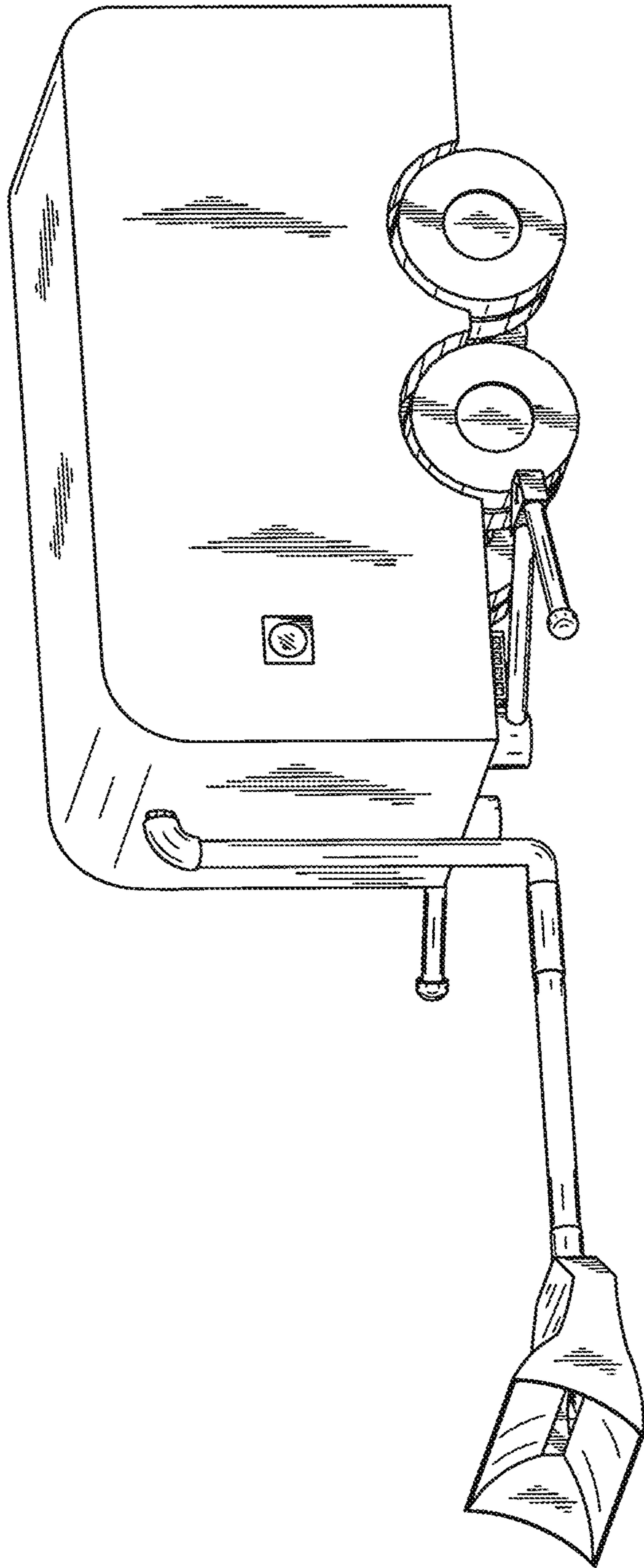

FIG. 2

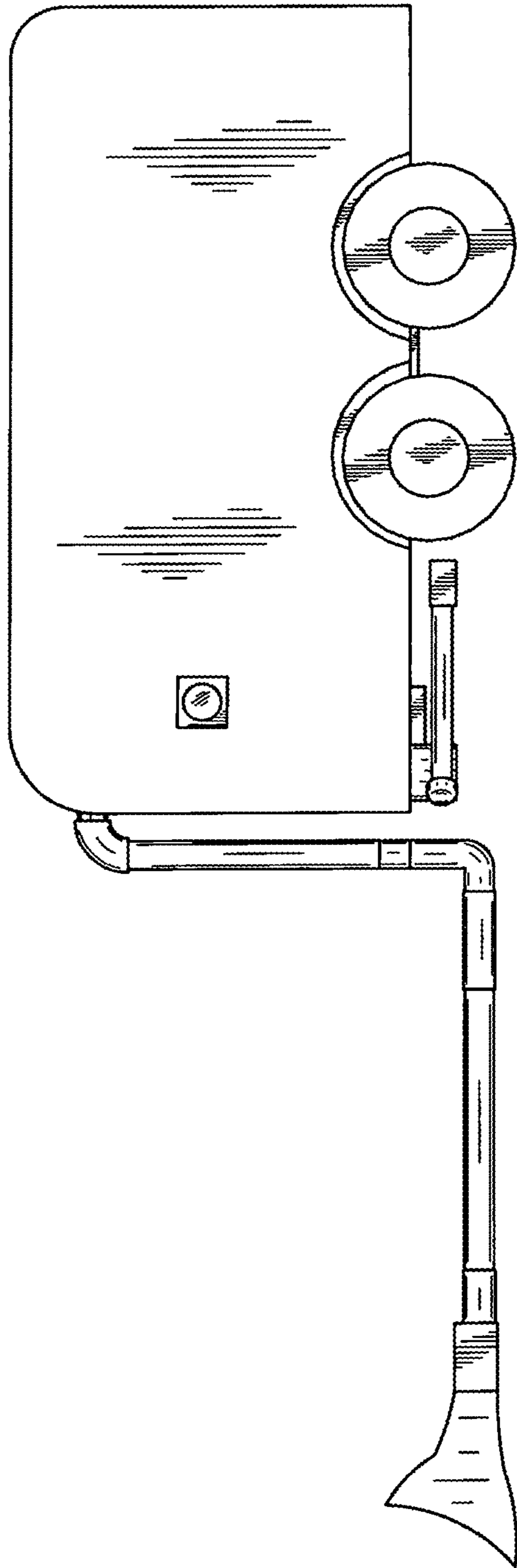

FIG. 3

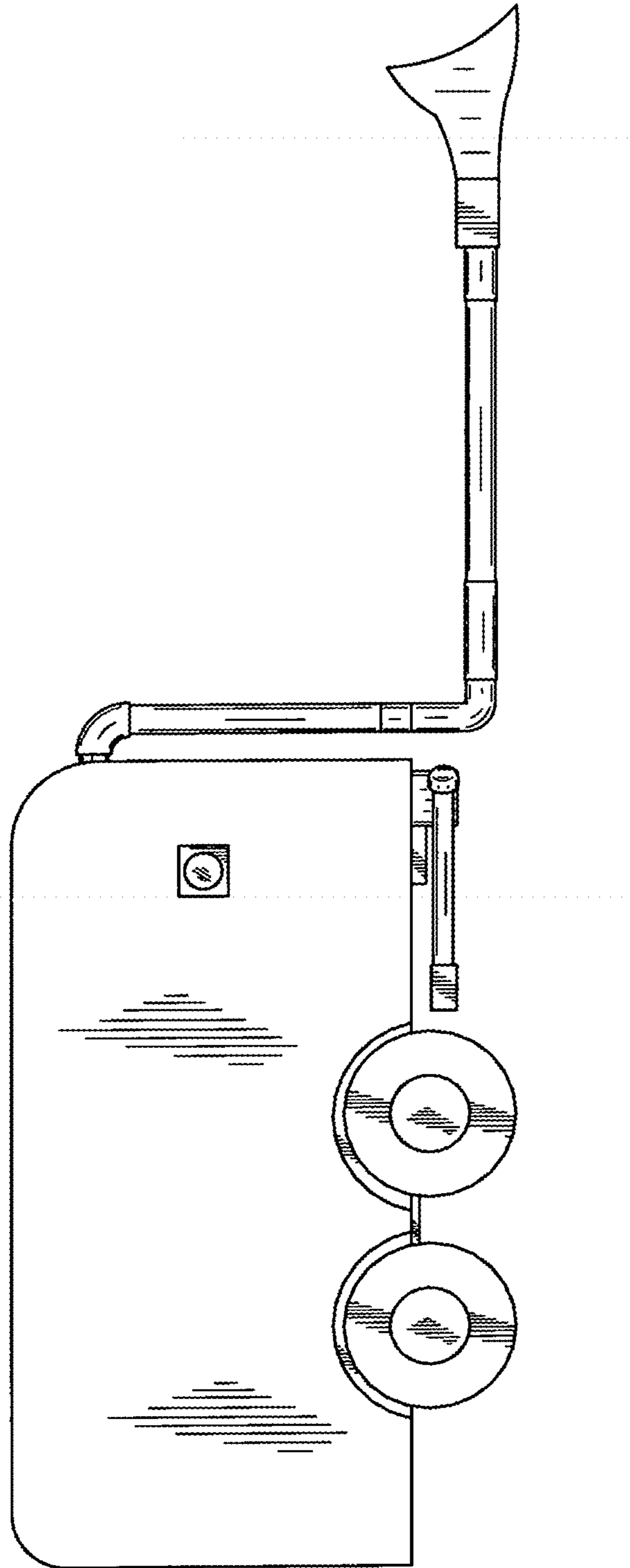

FIG. 4

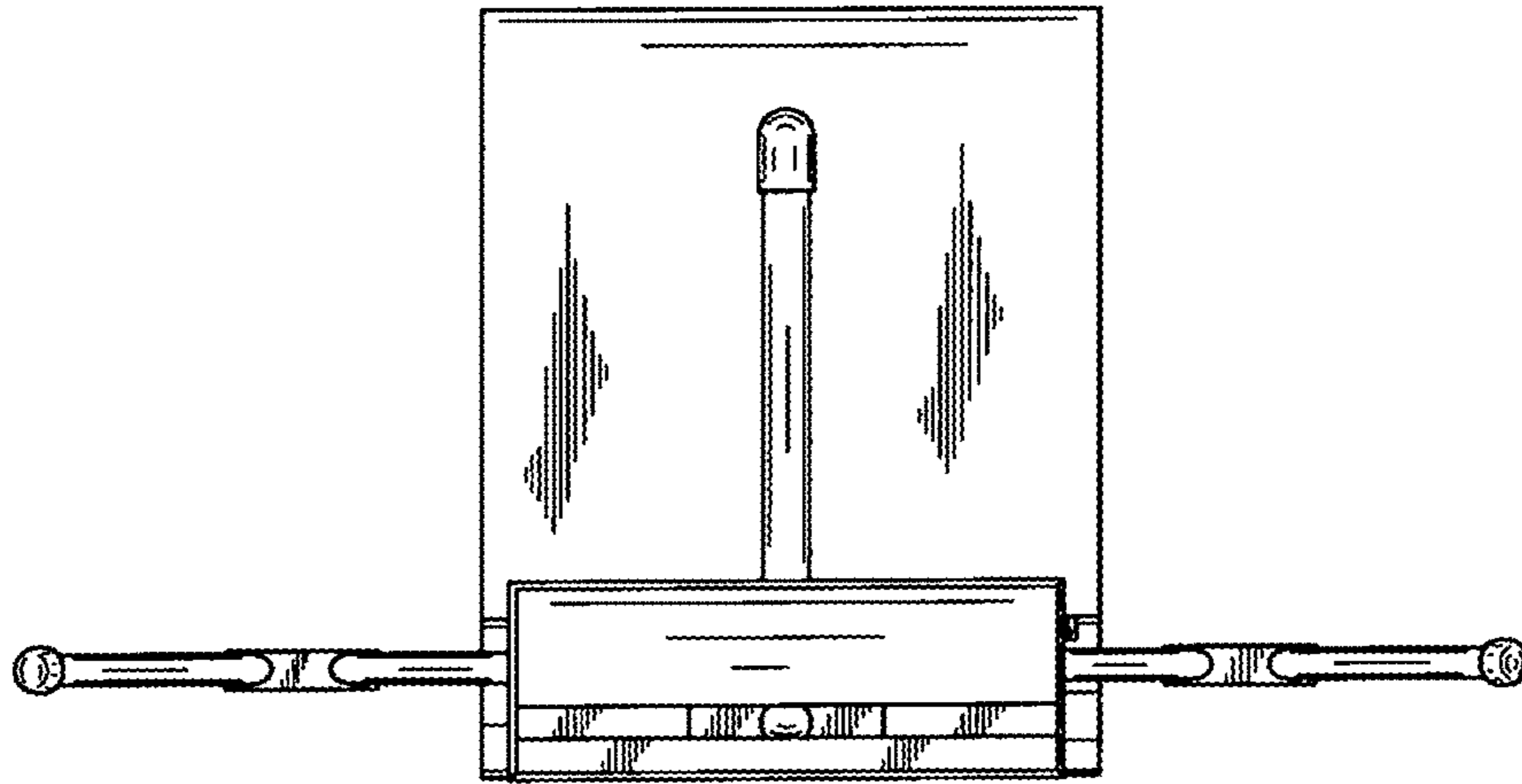

FIG. 5

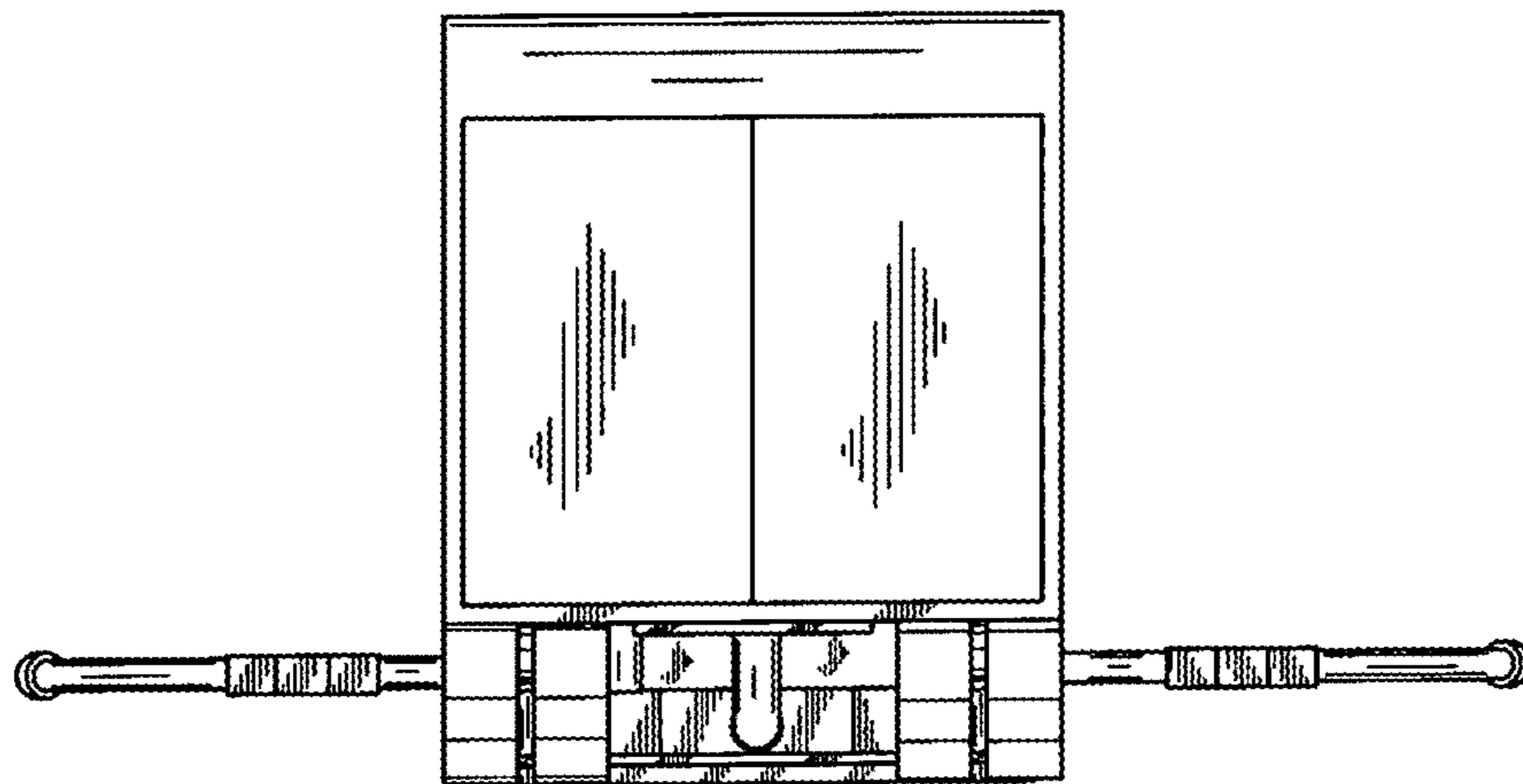

FIG. 6

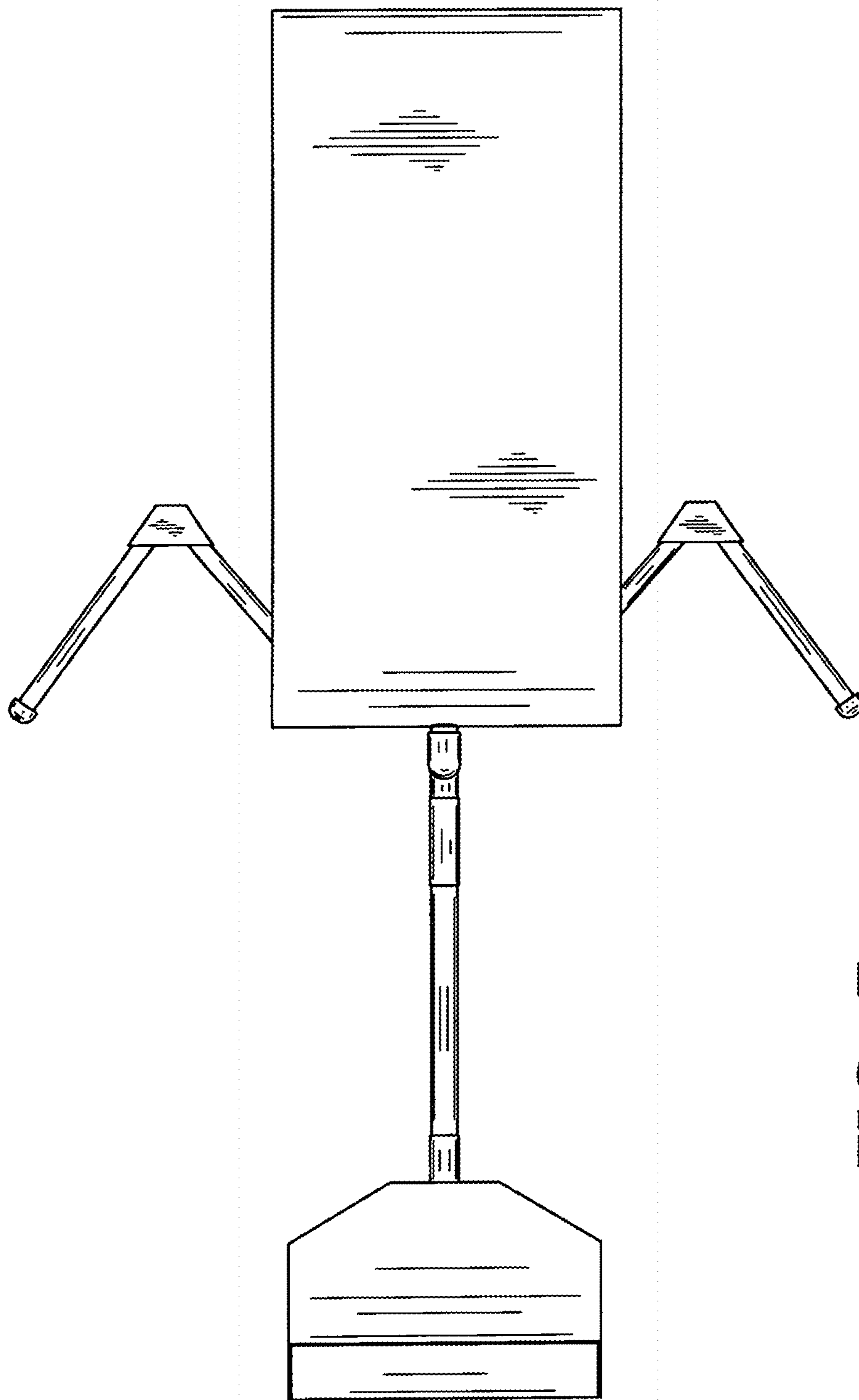

FIG. 7