



US00D902379S

(12) **United States Design Patent**
Trzeczieski

(10) **Patent No.:** **US D902,379 S**

(45) **Date of Patent:** **** Nov. 17, 2020**

(54) **COMPRESSED PHYTO MATERIAL TABLET**

(74) *Attorney, Agent, or Firm* — Bereskin & Parr LLP

(71) Applicant: **Michael Alexander Trzeczieski**, Toronto (CA)

(57) **CLAIM**

The ornamental design for a compressed phyto material tablet, as described and shown.

(72) Inventor: **Michael Alexander Trzeczieski**, Toronto (CA)

DESCRIPTION

(73) Assignee: **GSEH HOLISTIC, INC.**, Vancouver (CA)

FIG. 1 is a perspective view from the rear and right side of a first variant of a compressed phyto material tablet; FIG. 2 is a perspective view from the front and right side of the compressed phyto material tablet of FIG. 1; FIG. 3 is a top view of the compressed phyto material tablet of FIG. 1;

(**) Term: **15 Years**

(21) Appl. No.: **29/634,832**

FIG. 4 is a bottom view of the compressed phyto material tablet of FIG. 1;

(22) Filed: **Jan. 25, 2018**

(51) **LOC (12) Cl.** **24-01**

FIG. 5 is a front view of the compressed phyto material tablet of FIG. 1;

(52) **U.S. Cl.**

USPC **D24/101**

FIG. 6 is a rear view of the compressed phyto material tablet of FIG. 1;

(58) **Field of Classification Search**

USPC D24/100–104; D1/100

CPC A61K 9/20; A61K 9/209; A61K 9/2077;

A61K 9/5078; A61K 9/4891; A61K

9/167; A61K 9/2072; A61K 9/2081;

A61K 9/2086; A61K 8/11

See application file for complete search history.

FIG. 7 is a left side view of the compressed phyto material tablet of FIG. 1;

FIG. 8 is a right side view of the compressed phyto material tablet of FIG. 1;

FIG. 9 is a perspective view from the rear and right side of a second variant of a compressed phyto material tablet;

FIG. 10 is a perspective view from the front and right side of the compressed phyto material tablet of FIG. 9;

FIG. 11 is a top view of the compressed phyto material tablet of FIG. 9;

FIG. 12 is a bottom view of the compressed phyto material tablet of FIG. 9;

FIG. 13 is a front view of the compressed phyto material tablet of FIG. 9;

FIG. 14 is a rear view of the compressed phyto material tablet of FIG. 9;

FIG. 15 is a left side view of the compressed phyto material tablet of FIG. 9; and,

FIG. 16 is a right side view of the compressed phyto material tablet of FIG. 9.

(56) **References Cited**

U.S. PATENT DOCUMENTS

D309,506 S *	7/1990	Shurkus	D24/103
D334,968 S *	4/1993	Gladfelter	D23/207
5,391,378 A *	2/1995	Sanderson	A61J 3/10
				424/464
D356,375 S *	3/1995	McGuffey	D24/103
D373,187 S *	8/1996	Dickinson	D24/103
D516,668 S *	3/2006	Costa	D23/208
D592,273 S *	5/2009	Eisch	D23/207
D632,386 S *	2/2011	Chang	D24/101
D636,070 S *	4/2011	Illing	D24/101
D717,423 S *	11/2014	Heit	D24/101

(Continued)

Primary Examiner — Charles D Hanson

1 Claim, 4 Drawing Sheets

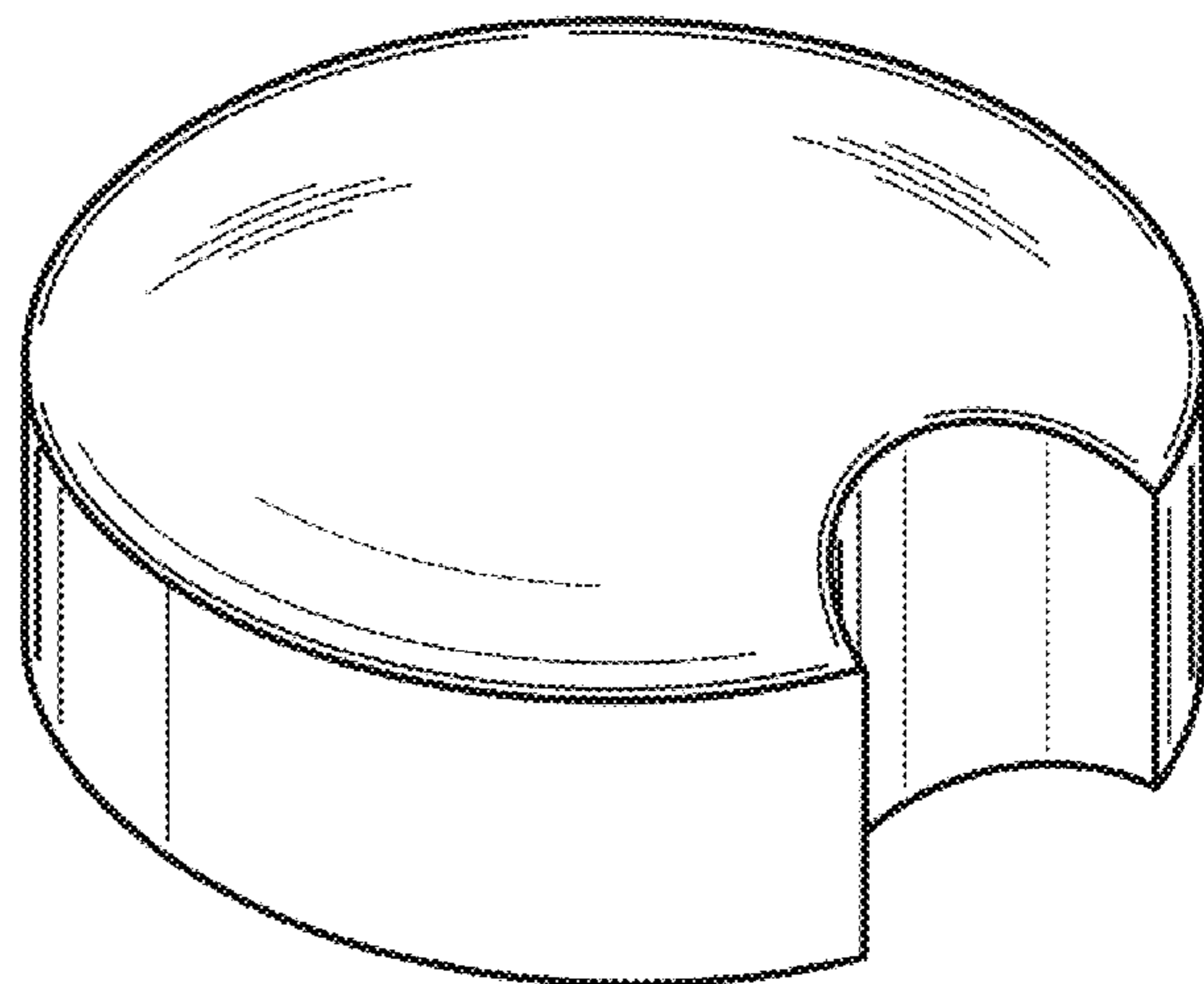
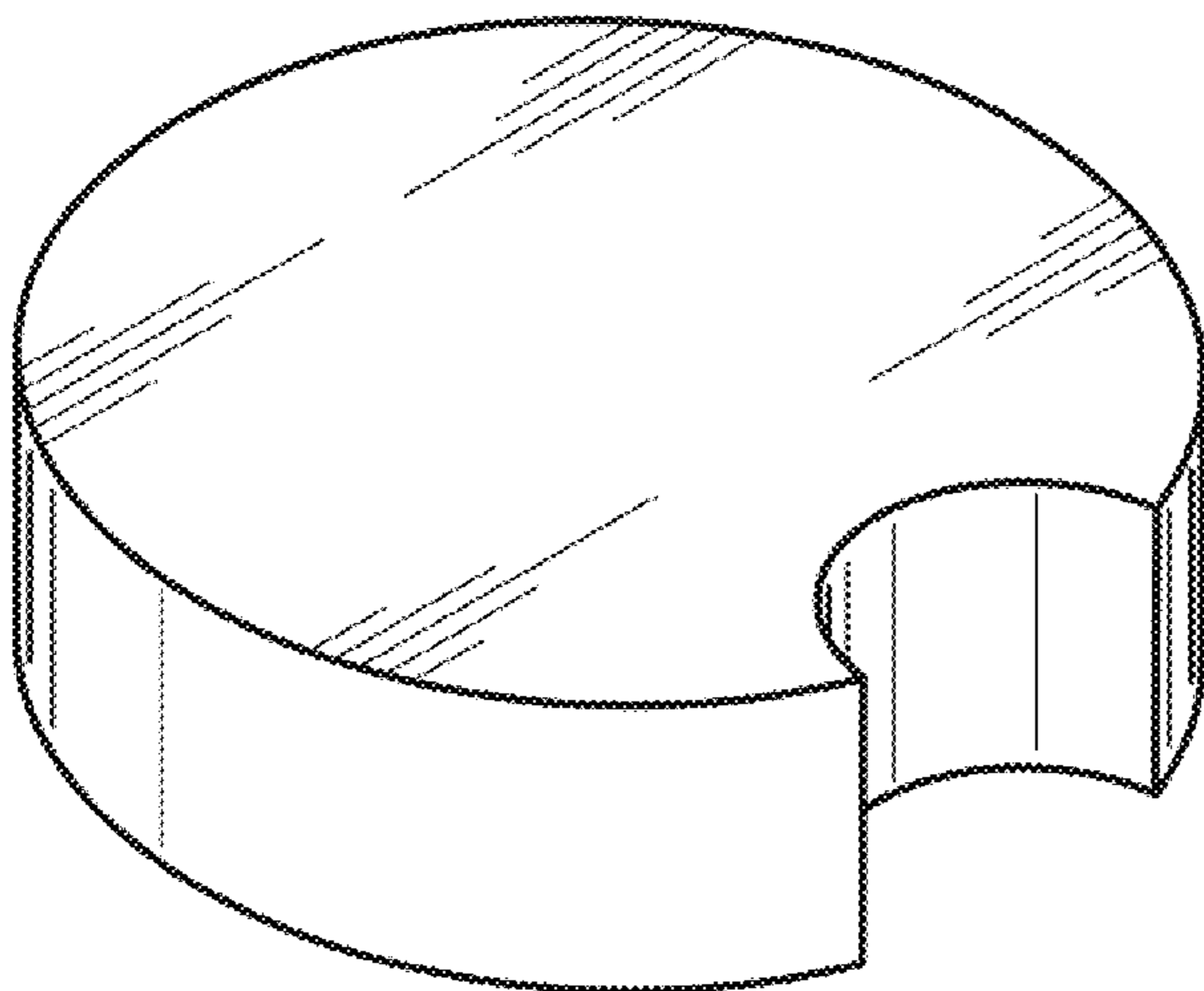

(56)

References Cited

U.S. PATENT DOCUMENTS

D736,369 S * 8/2015 Bruining D24/101
D745,659 S * 12/2015 Bruining D24/101
D768,283 S * 10/2016 Evans, II D1/114

* cited by examiner

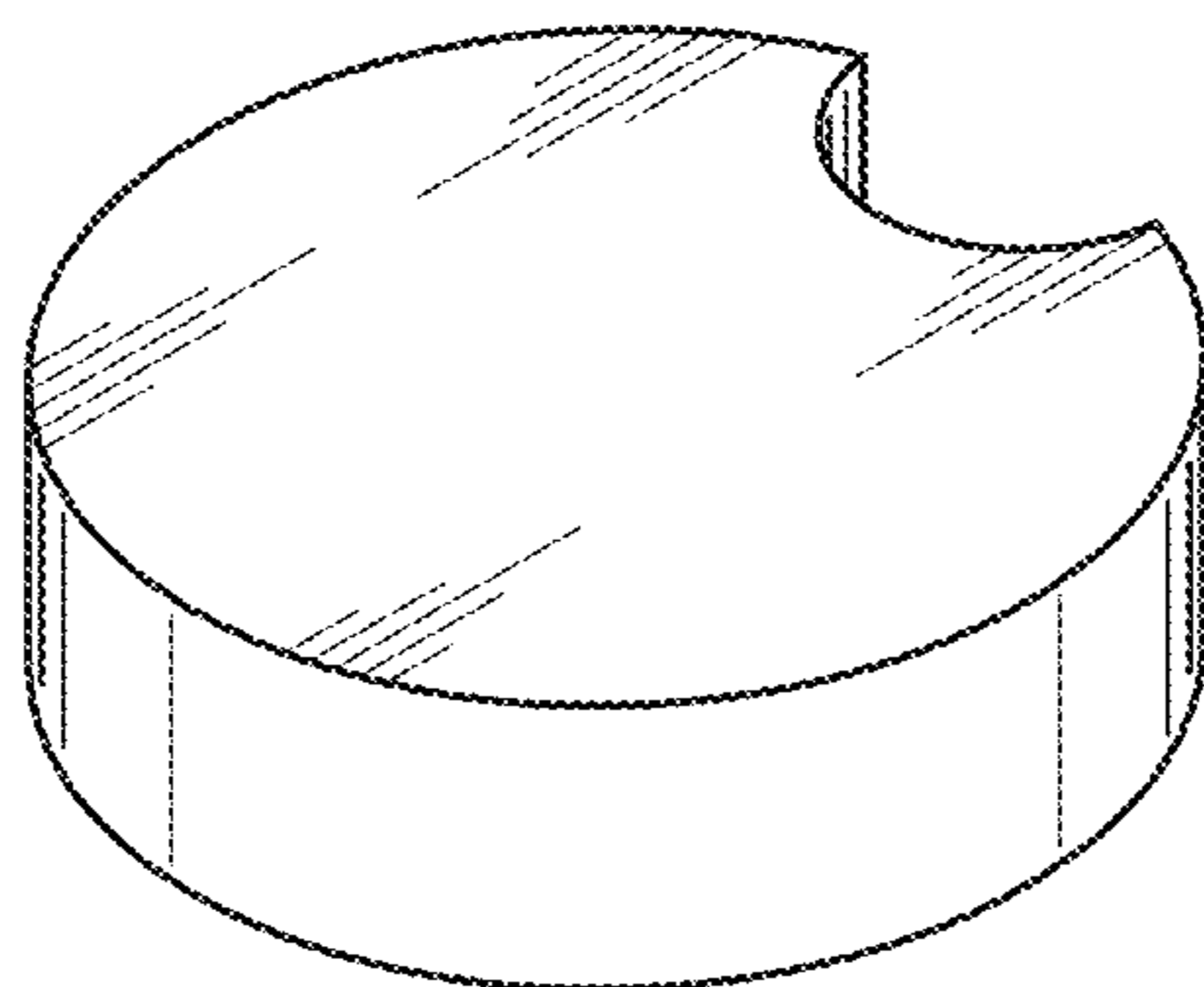

FIG. 1

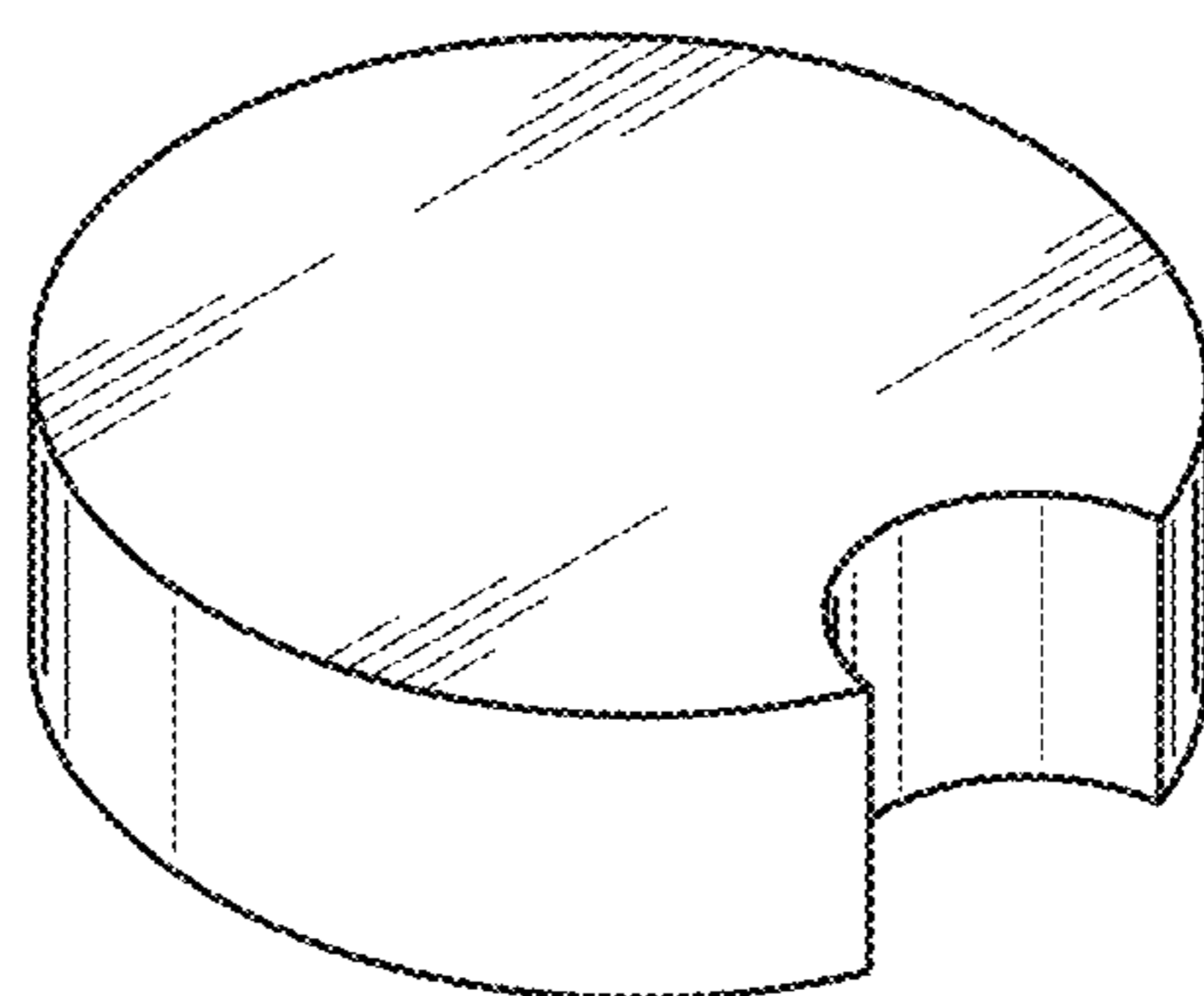

FIG. 2

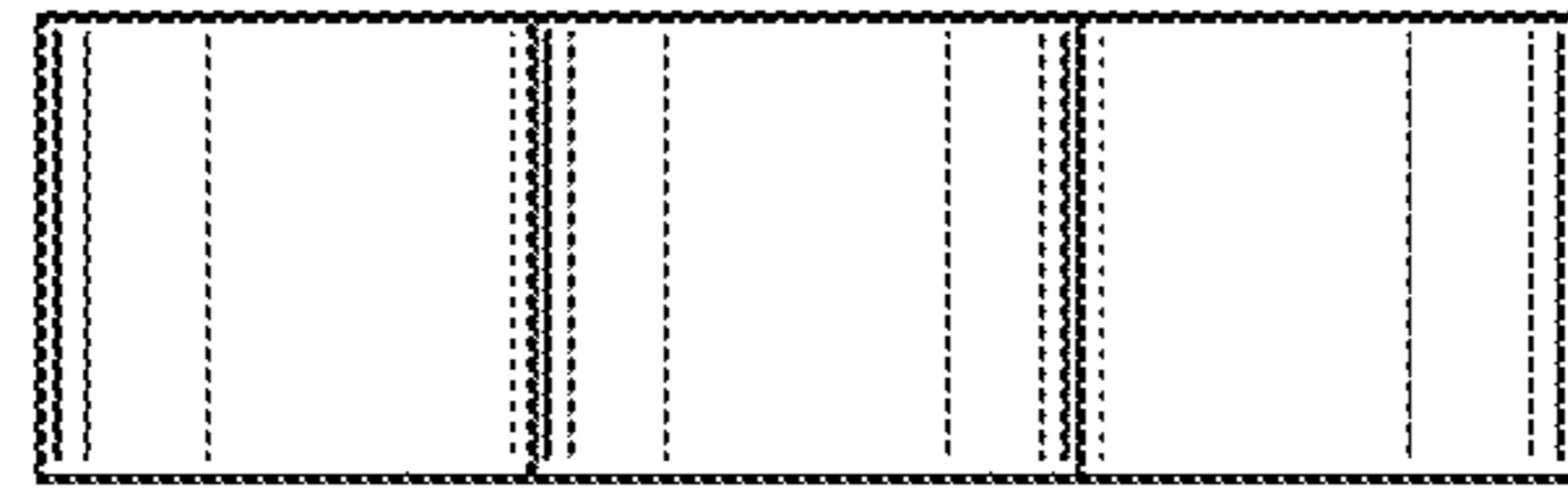

FIG. 5

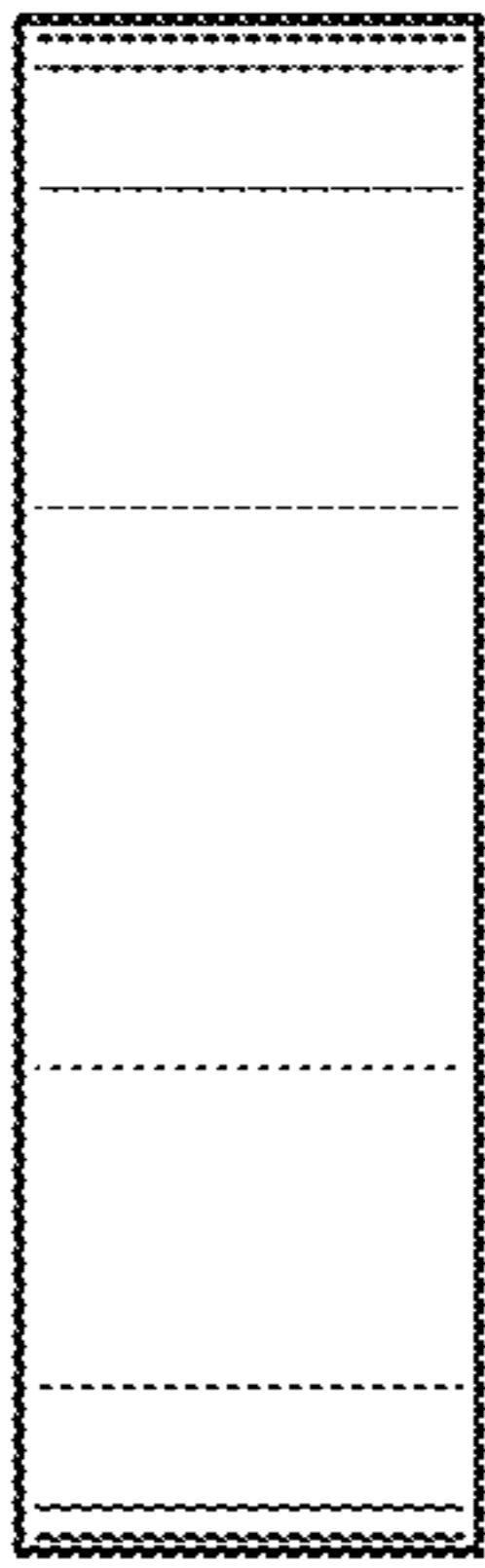

FIG. 7

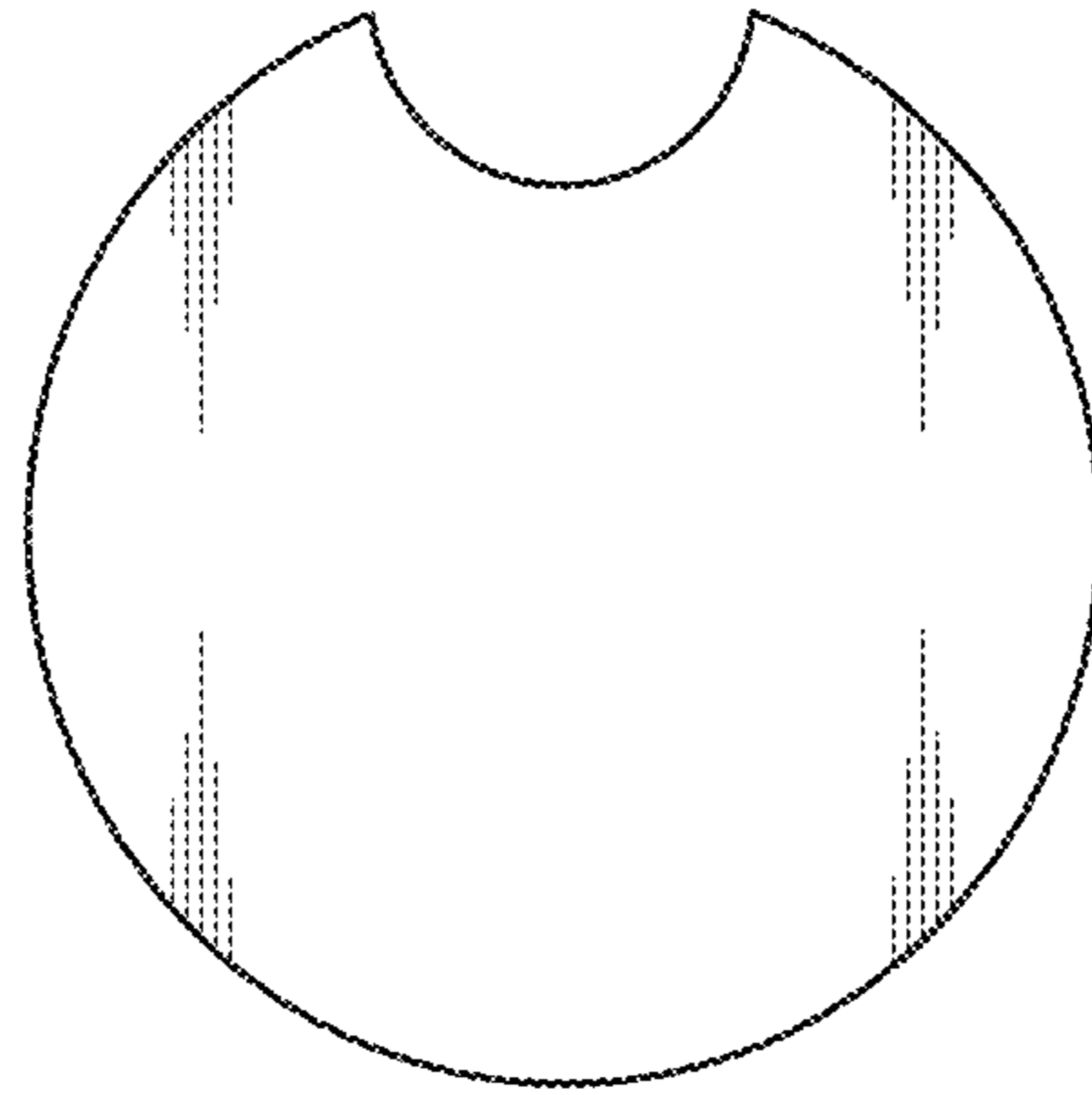

FIG. 3



FIG. 8



FIG. 6

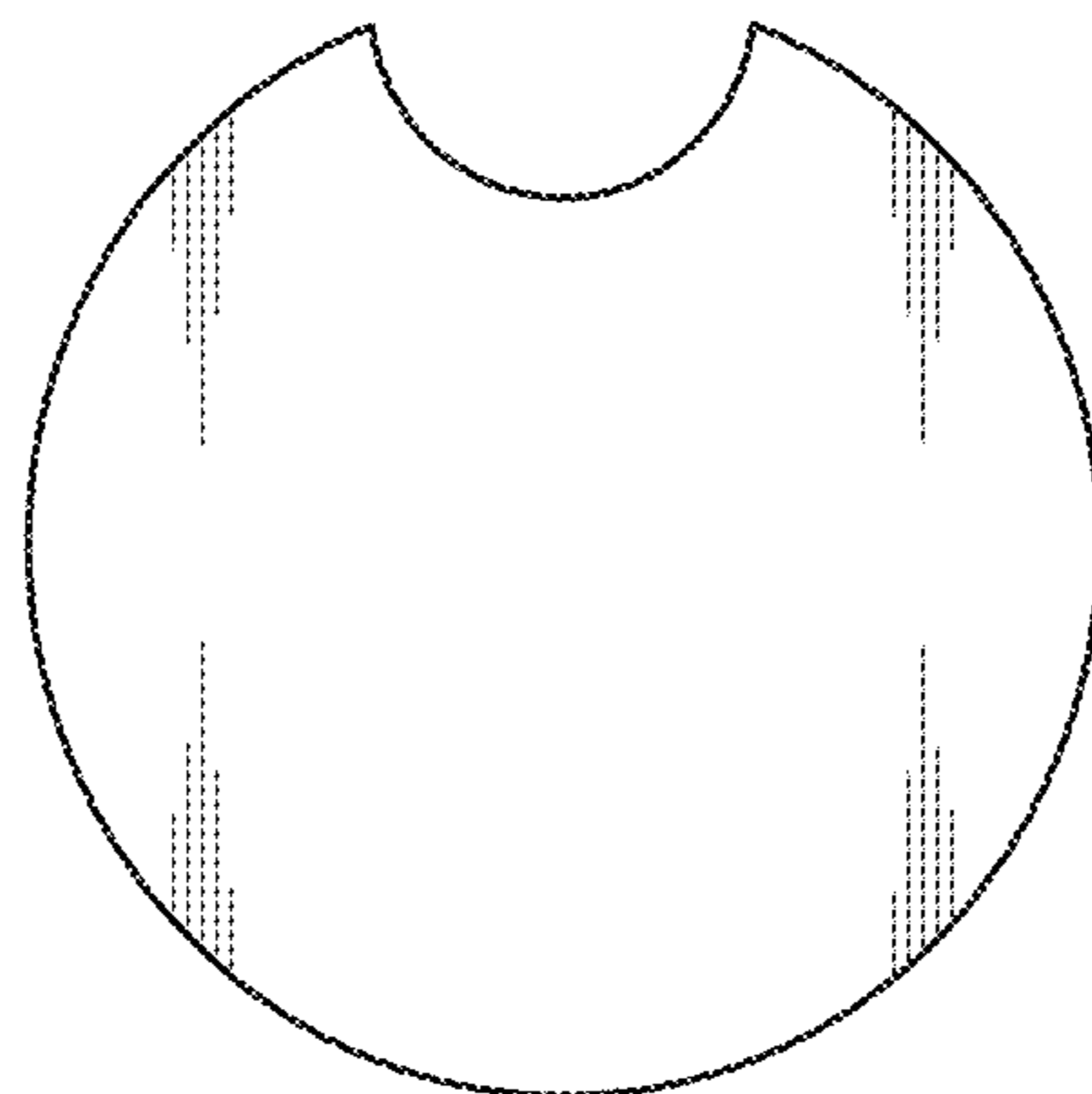

FIG. 4

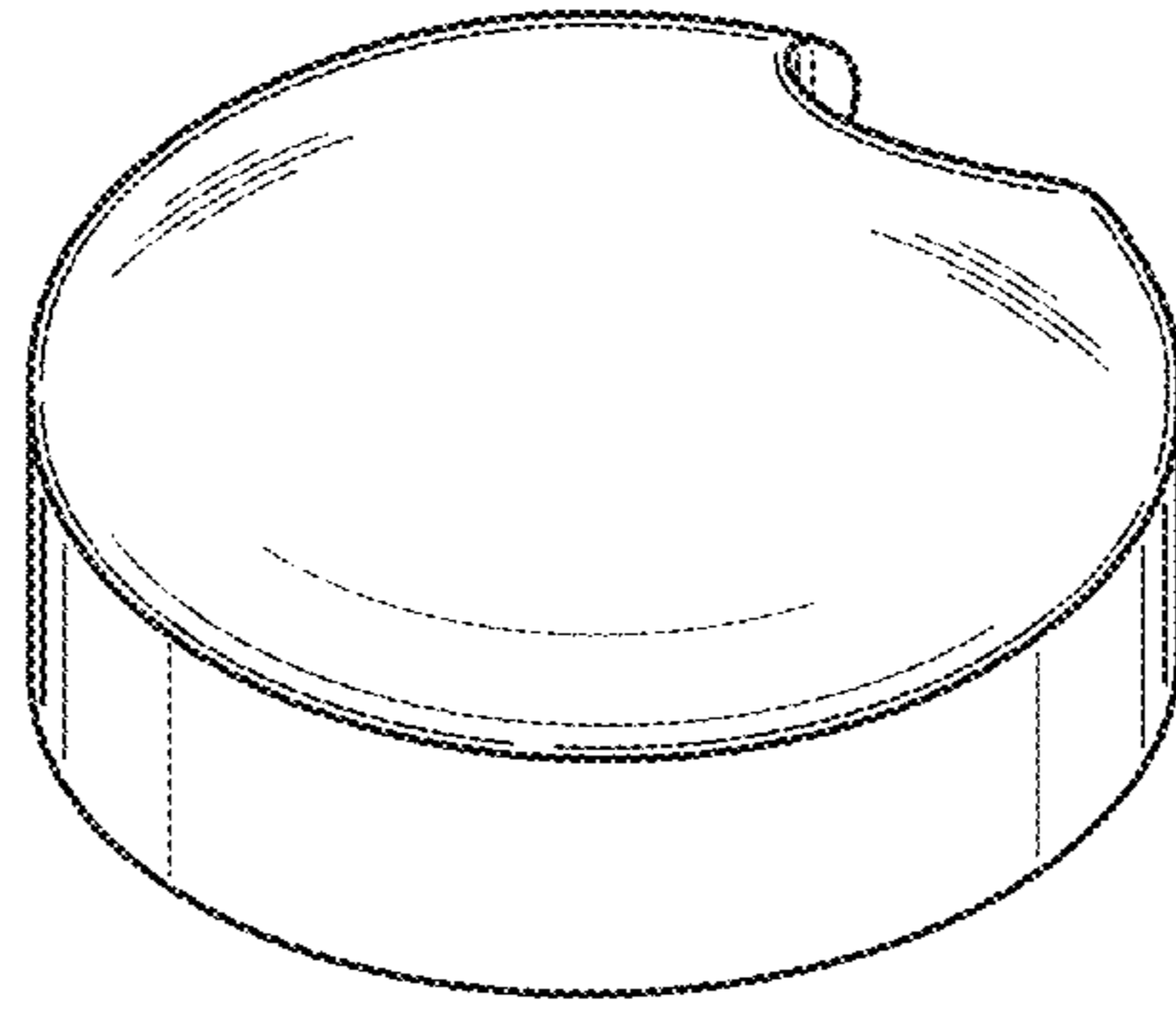

FIG. 9

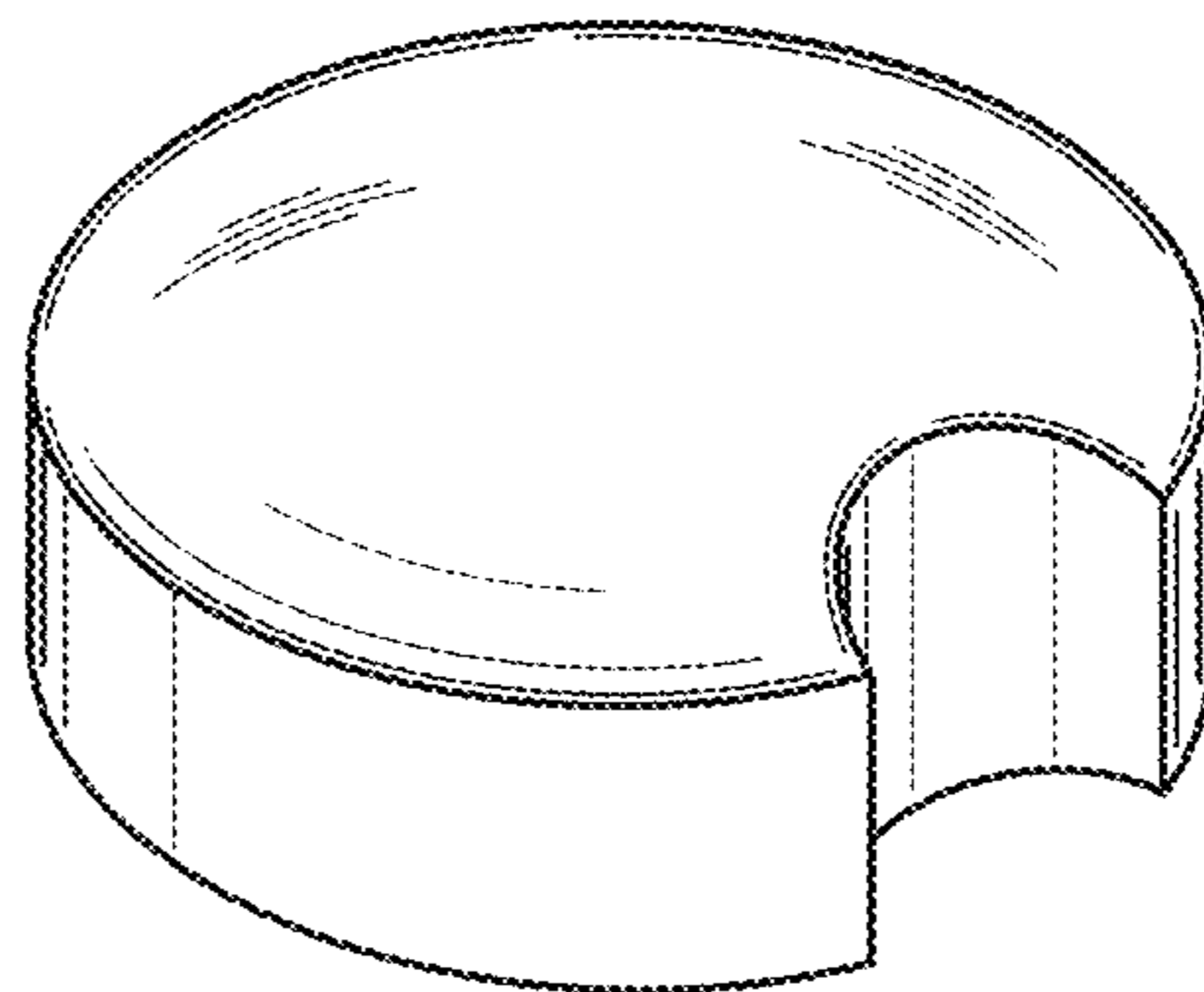

FIG. 10

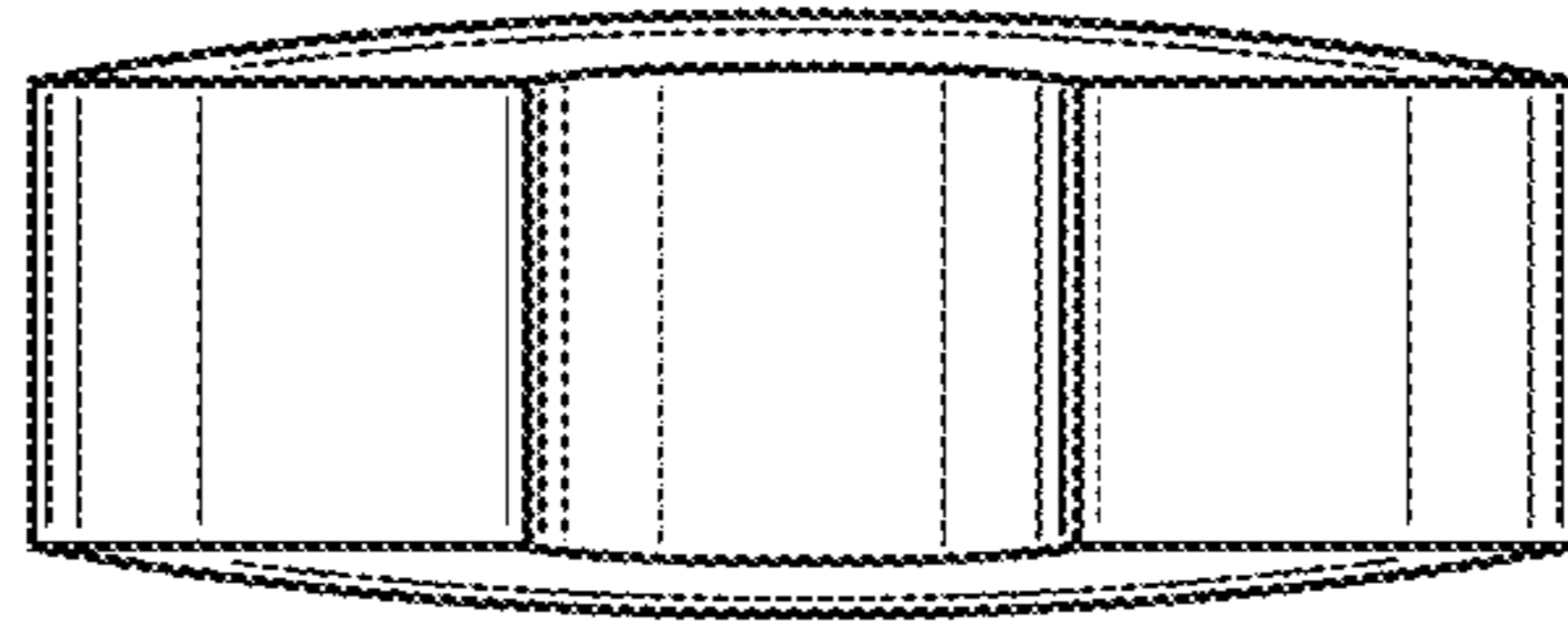

FIG. 13

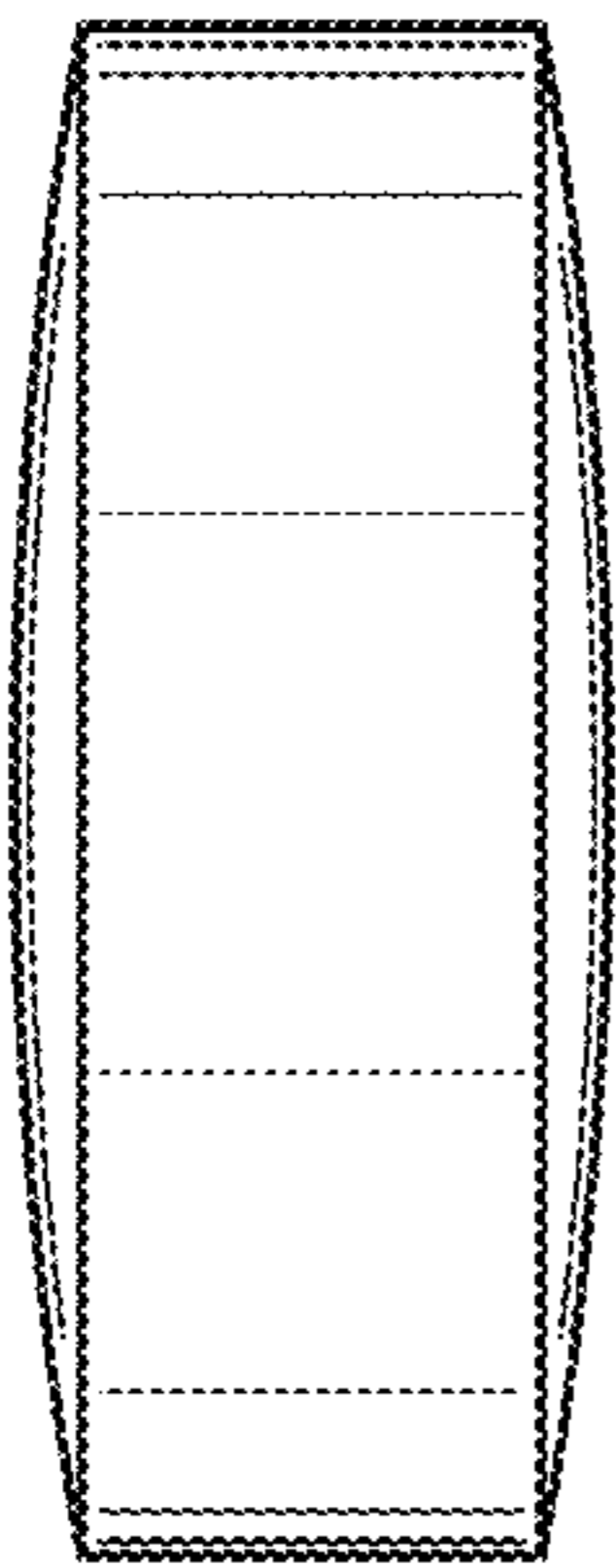

FIG. 15

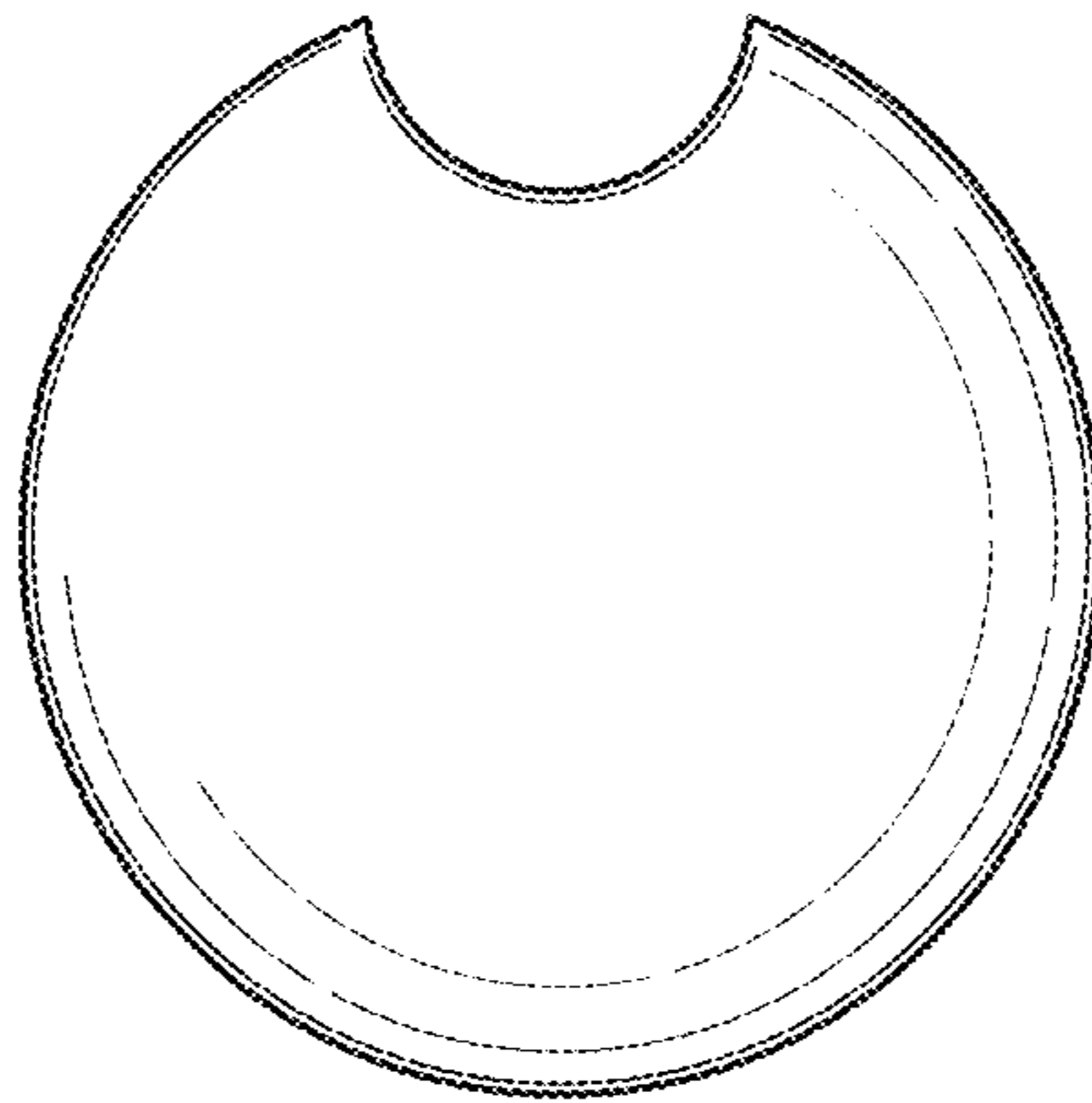

FIG. 11

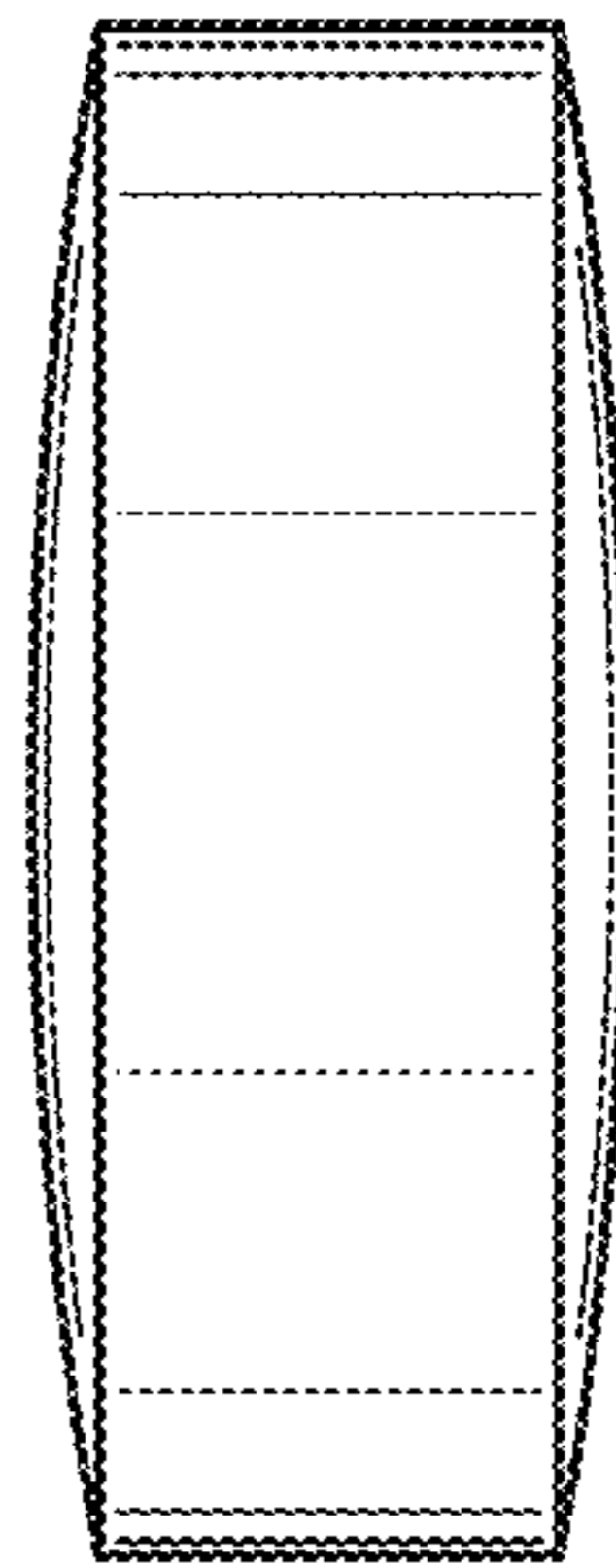

FIG. 16

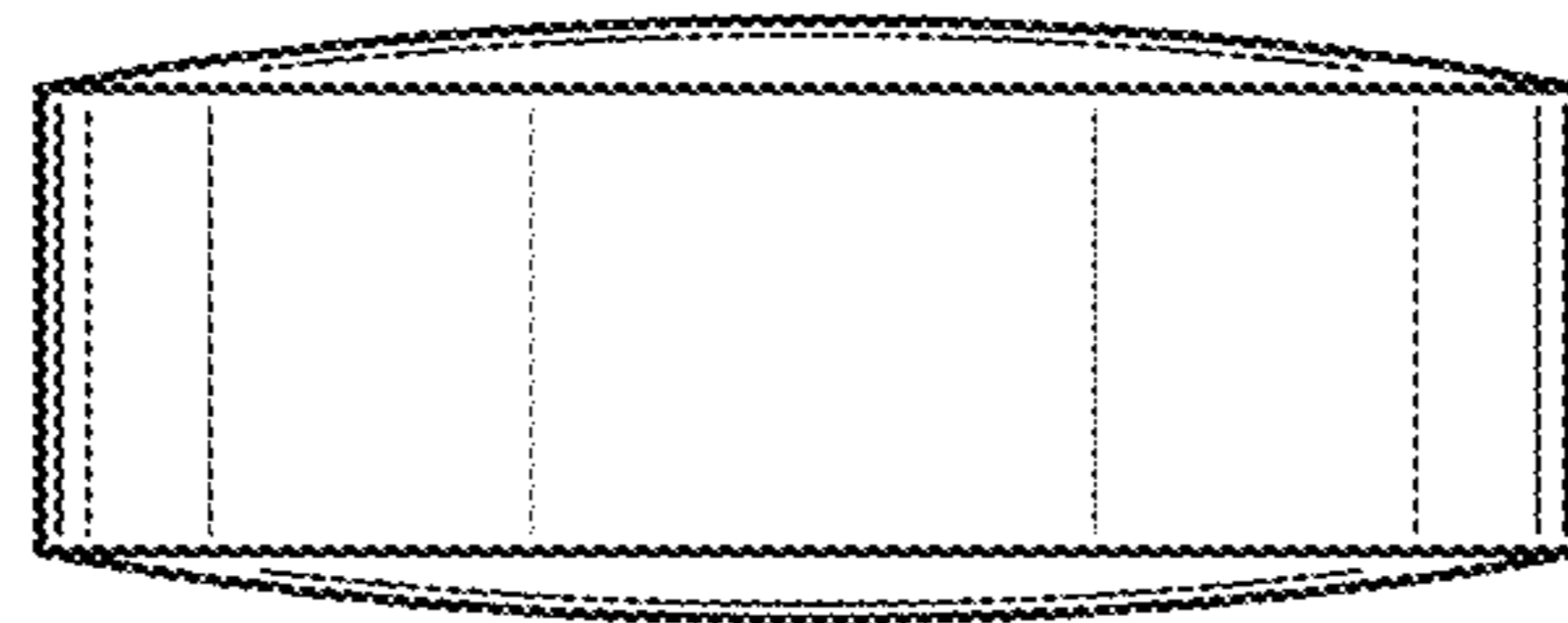

FIG. 14

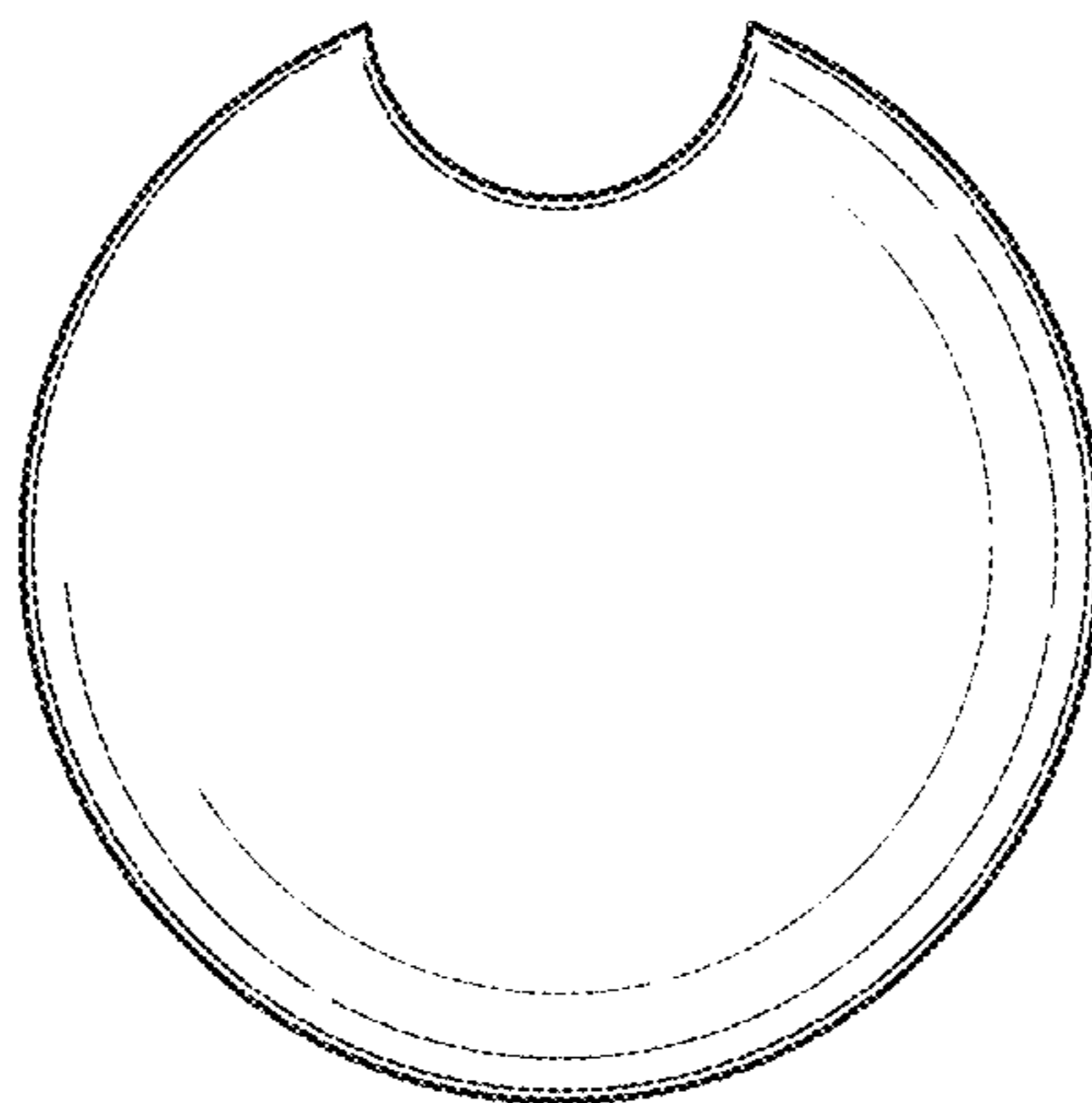

FIG. 12