



US00D902318S

(12) **United States Design Patent**  
**Anderson et al.**

(10) **Patent No.:** **US D902,318 S**

(45) **Date of Patent:** **\*\* Nov. 17, 2020**

(54) **SAFETY RAIL FOR A MARINE VESSEL**  
(71) Applicant: **Brunswick Corporation**, Mettawa, IL (US)  
(72) Inventors: **Kevin R. Anderson**, Fond du Lac, WI (US); **Scott G. Ahlswede**, Plymouth, WI (US); **Miles F. Gathright**, New Smyrna Beach, FL (US)

5,649,688 A \* 7/1997 Baker ..... E04F 11/181 256/21  
D389,460 S \* 1/1998 Wei-Hong ..... D13/155  
5,706,753 A \* 1/1998 Menne ..... B63B 17/02 114/361  
5,779,228 A 7/1998 Hansen  
6,796,101 B2 \* 9/2004 Chen ..... E04F 11/1851 52/781  
6,901,875 B1 6/2005 Beal et al.  
D509,906 S \* 9/2005 Enersen ..... D25/38.1  
(Continued)

(73) Assignee: **Brunswick Corporation**, Mettawa, IL (US)

**FOREIGN PATENT DOCUMENTS**

(\*\*) Term: **15 Years**

GB 2383777 7/2003  
KR 10-1443781 3/2014

(21) Appl. No.: **29/648,354**

*Primary Examiner* — Cynthia M. Chin  
(74) *Attorney, Agent, or Firm* — Andrus Intellectual Property Law, LLP

(22) Filed: **May 21, 2018**

(51) **LOC (12) Cl.** ..... **12-06**

(52) **U.S. Cl.**  
USPC ..... **D21/317; D25/38.1**

(58) **Field of Classification Search**  
USPC ..... D12/317, 318; D25/38.1, 39, 41.1, 124  
CPC ..... B63B 1/12; B63B 1/121; B63B 1/125; B63B 17/02; B63B 17/026; B63B 17/04  
See application file for complete search history.

(57) **CLAIM**

The ornamental design for a safety rail for a marine vessel, as shown and described.

**DESCRIPTION**

FIG. 1 is a front perspective view of a safety rail installed on an exemplary marine vessel.  
FIG. 2 is a front perspective view of the safety rail.  
FIG. 3 is a front view thereof.  
FIG. 4 is a rear view thereof.  
FIG. 5 is an end view thereof.  
FIG. 6 is an opposite end view thereof.  
FIG. 7 is a top view thereof; and,  
FIG. 8 is a bottom view thereof.  
The broken lines in FIG. 1 represent the environment in which the article resides. Broken lines in all other figures represent portions of the safety rail that form no part of the claim. The dash-dot broken lines immediately adjacent the shaded areas represent the bounds of the claim. None of the broken lines form a part of the claimed design.

(56) **References Cited**

**U.S. PATENT DOCUMENTS**

3,991,981 A 11/1976 Wu  
4,102,529 A 7/1978 Neblung et al.  
D258,279 S \* 2/1981 Moore ..... D12/302  
D269,910 S \* 7/1983 Johansson ..... D25/124  
4,475,840 A 10/1984 Schmitt et al.  
5,200,240 A \* 4/1993 Baker ..... E04F 11/1853 428/34.1  
D335,353 S \* 5/1993 Baker ..... D25/38.1  
D353,467 S \* 12/1994 Raynes ..... D25/125  
D361,153 S \* 8/1995 Fernandes ..... D13/155  
D378,432 S \* 3/1997 Raynes ..... G09B 21/003 D25/164

**1 Claim, 5 Drawing Sheets**

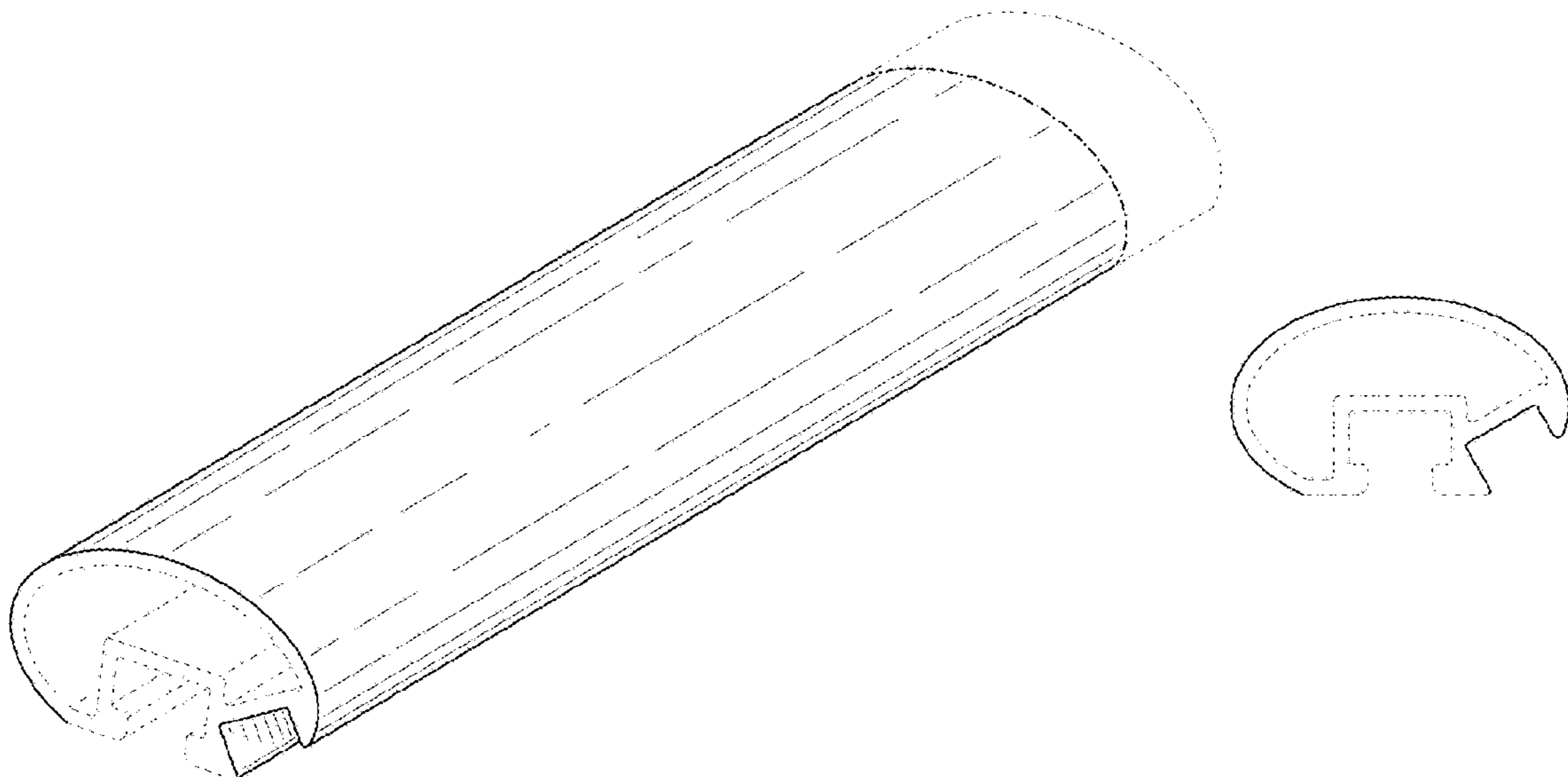

(56)

**References Cited**

## U.S. PATENT DOCUMENTS

7,017,320 B2 \* 3/2006 Chen ..... E04F 11/1817  
52/781  
D613,420 S \* 4/2010 Matheisl ..... D25/38.1  
8,356,802 B2 \* 1/2013 Reich ..... E04F 11/1836  
256/65.16  
8,567,333 B2 10/2013 Berman et al.  
D720,477 S \* 12/2014 Ross ..... D25/121  
8,905,570 B2 12/2014 Hartman  
9,068,361 B2 \* 6/2015 Quinn ..... F21V 33/006  
D751,243 S \* 3/2016 Seehof ..... D26/118  
D759,886 S \* 6/2016 Seehof ..... D26/118  
D759,887 S \* 6/2016 Seehof ..... D26/118  
D764,380 S \* 8/2016 Conrad ..... D12/317  
D768,050 S \* 10/2016 Conrad ..... D12/317  
D806,267 S \* 12/2017 Madden ..... D25/41.1  
D876,670 S \* 2/2020 Devitt ..... D25/41.1  
D877,933 S \* 3/2020 Devitt ..... D25/41.1  
D877,934 S \* 3/2020 Devitt ..... D25/41.1  
2008/0289294 A1 11/2008 Harrison et al.  
2011/0017969 A1 \* 1/2011 Reich ..... E04F 11/1836  
256/65.16  
2015/0152616 A1 6/2015 Taylor

\* cited by examiner

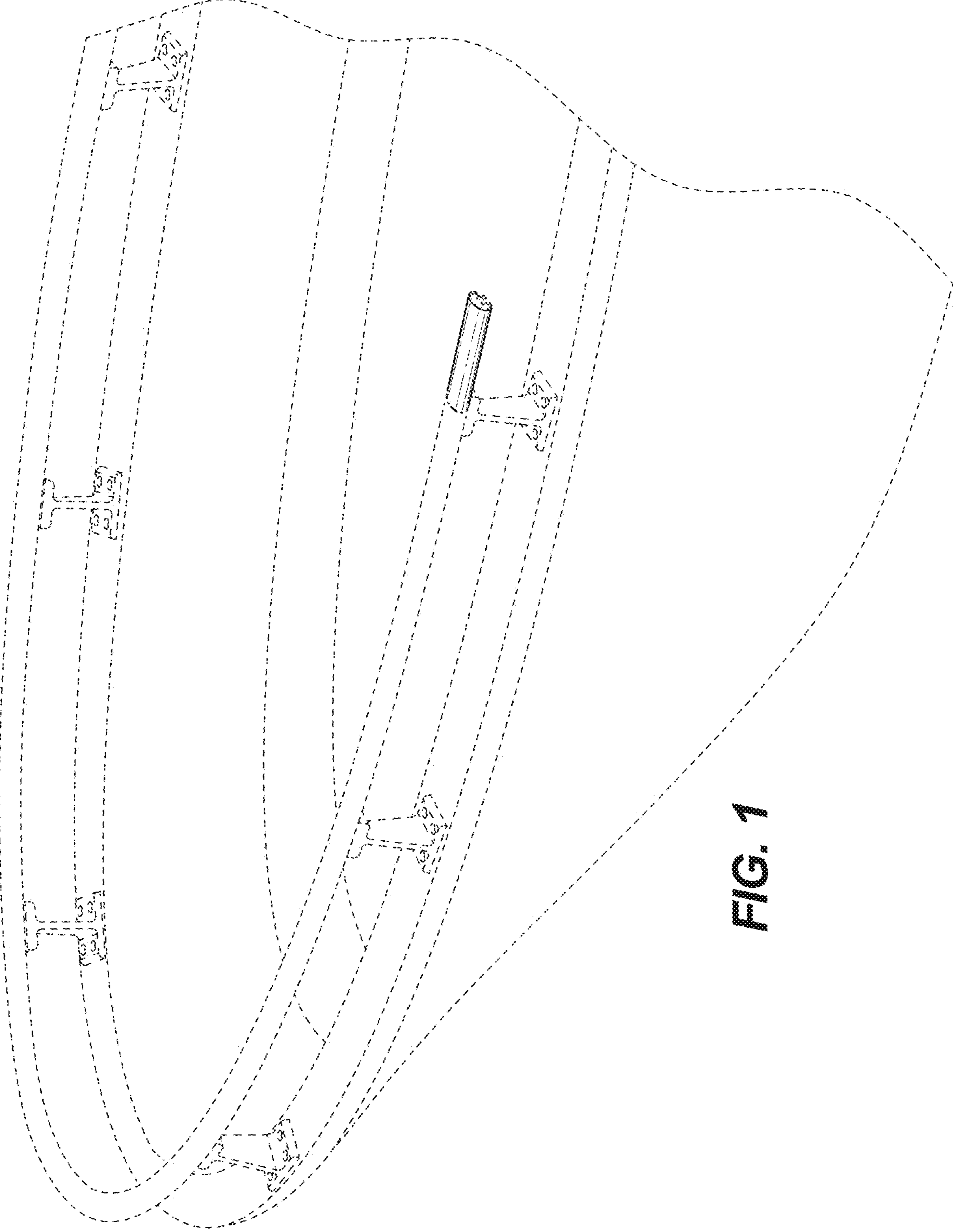

FIG. 1

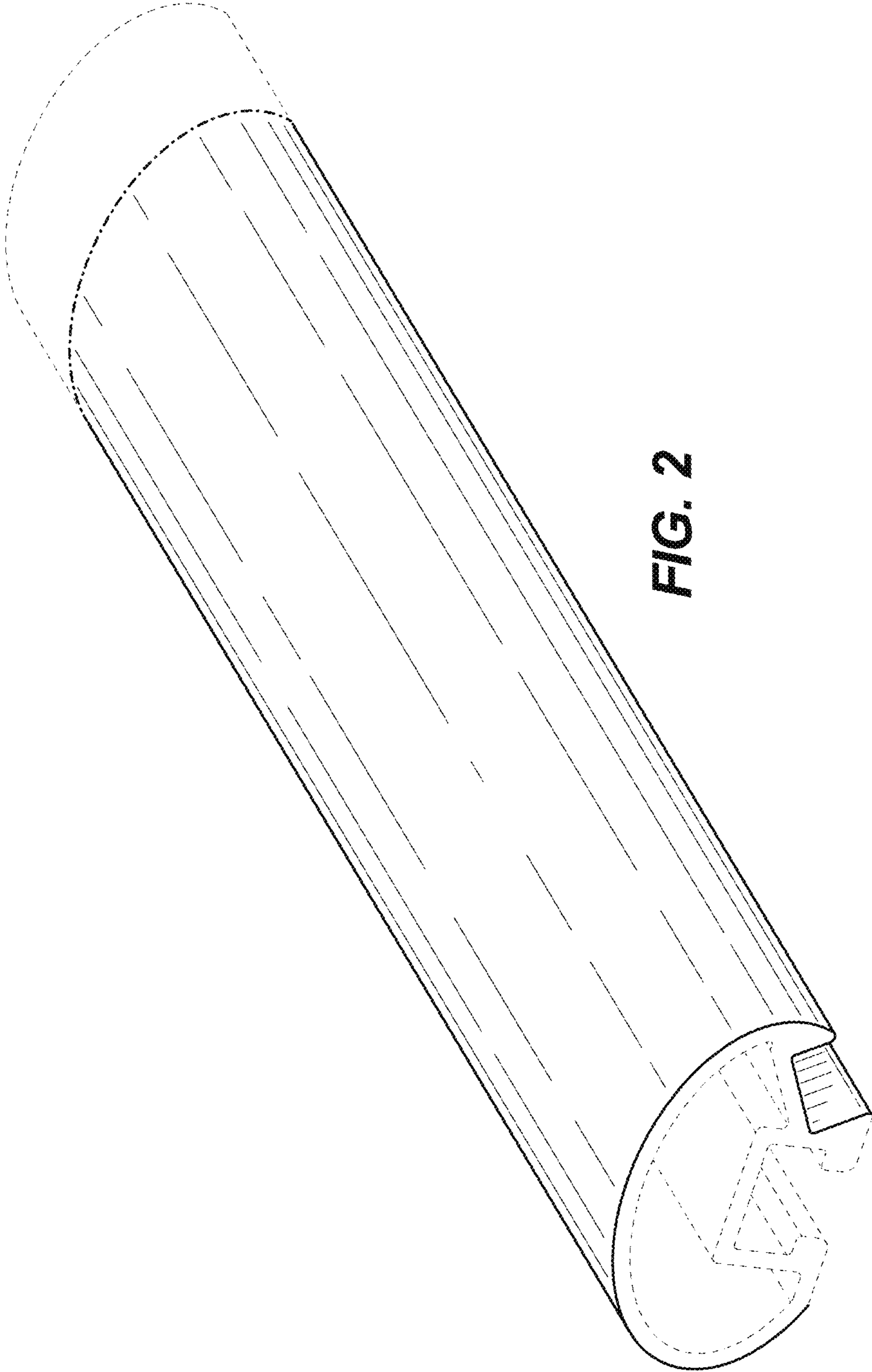
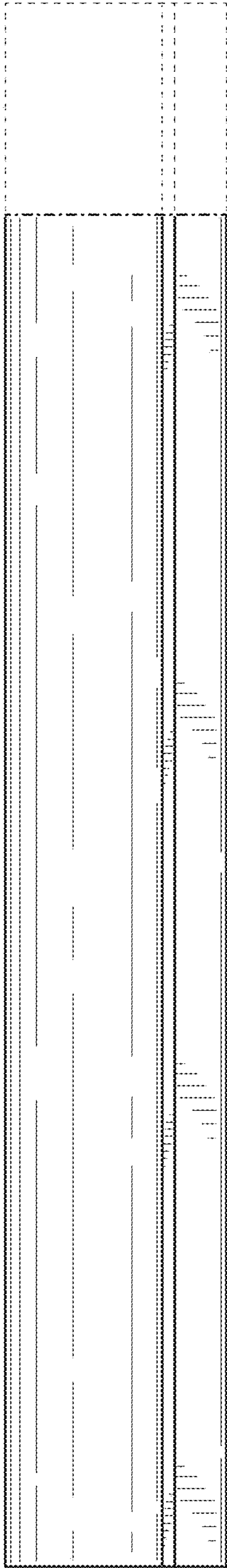
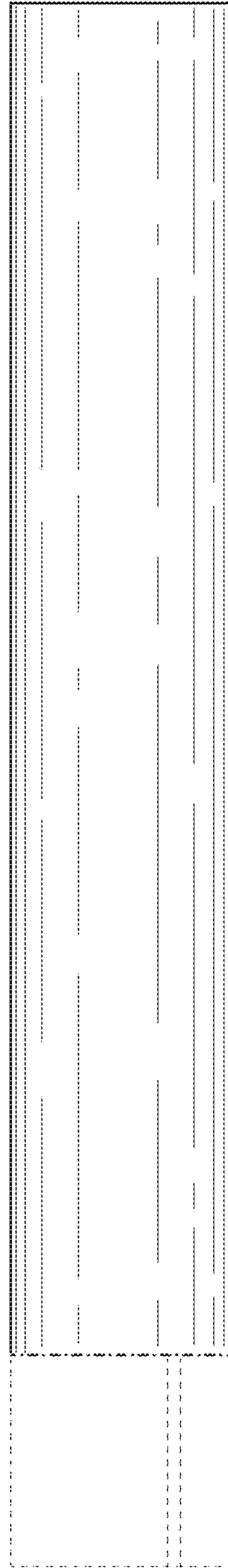

FIG. 2



**FIG. 3**



**FIG. 4**

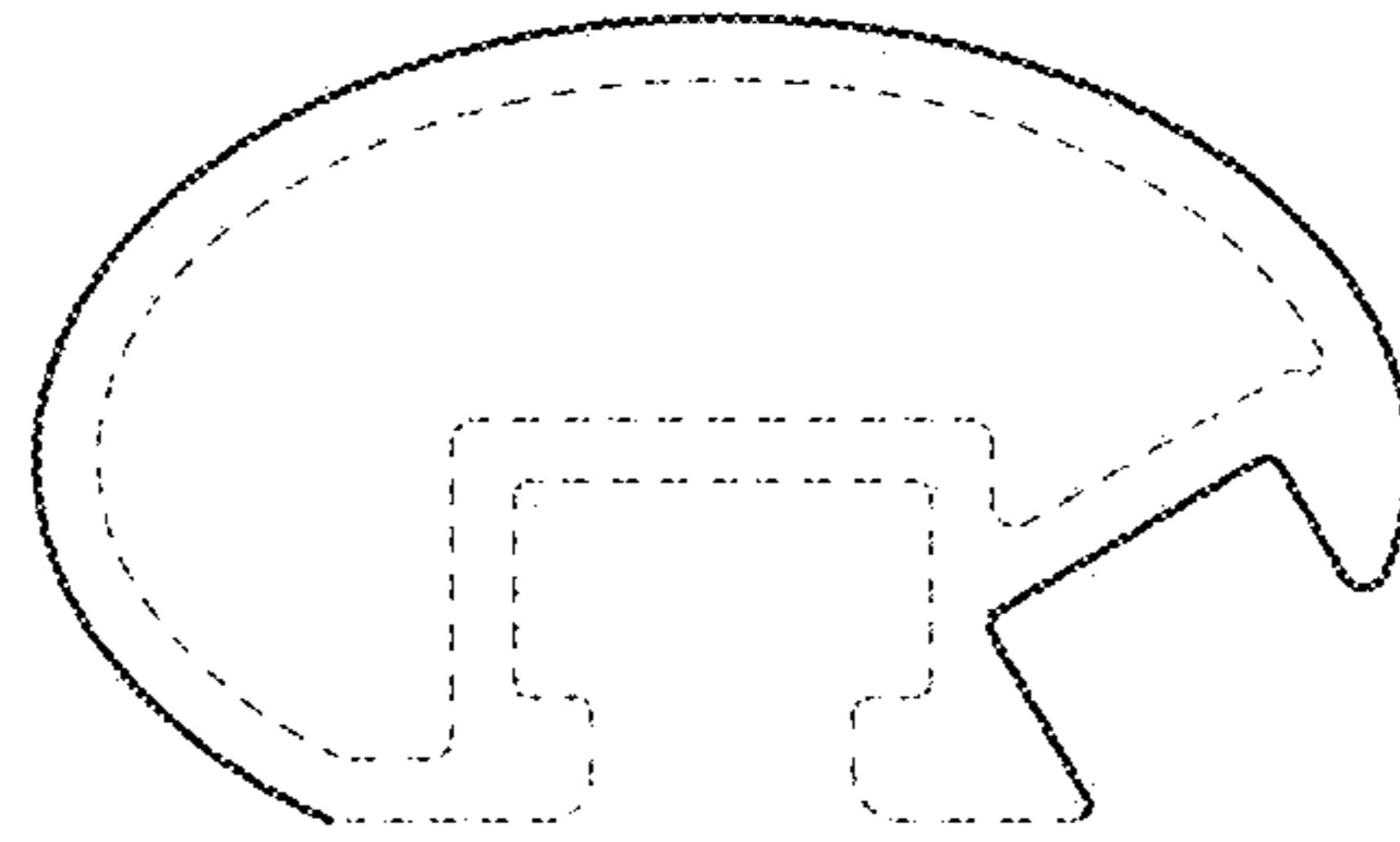

**FIG. 5**

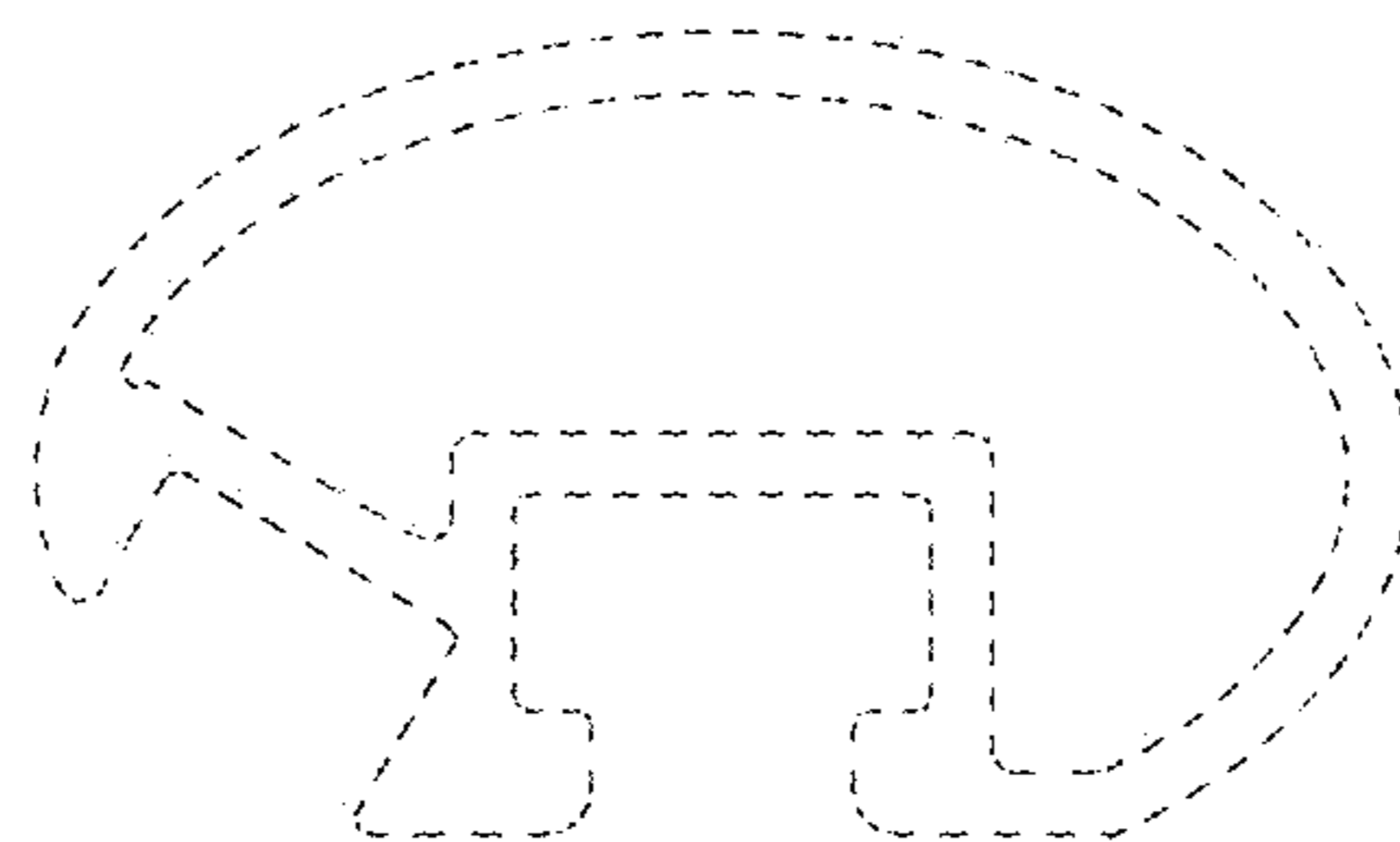

**FIG. 6**

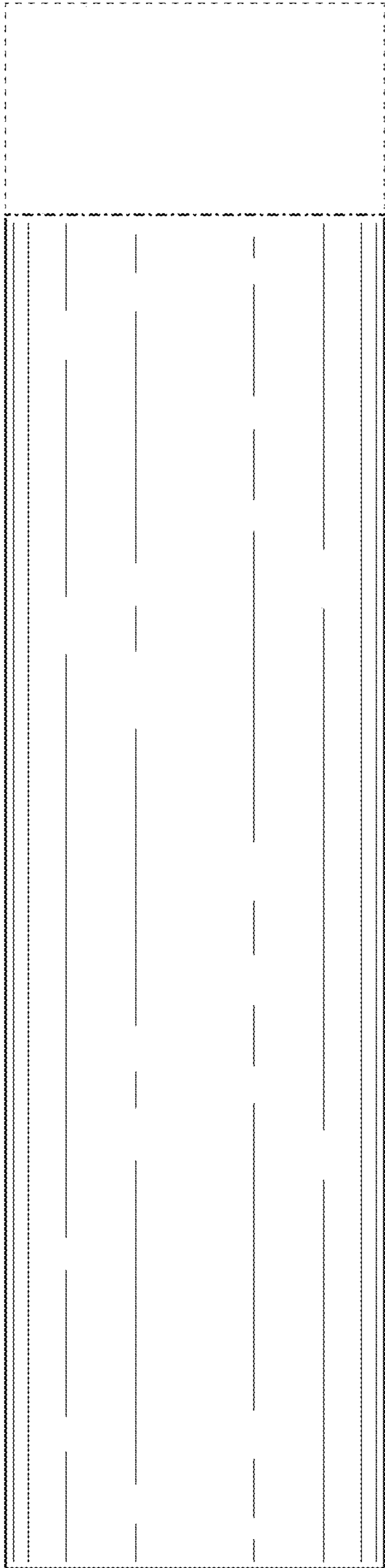

**FIG. 7**

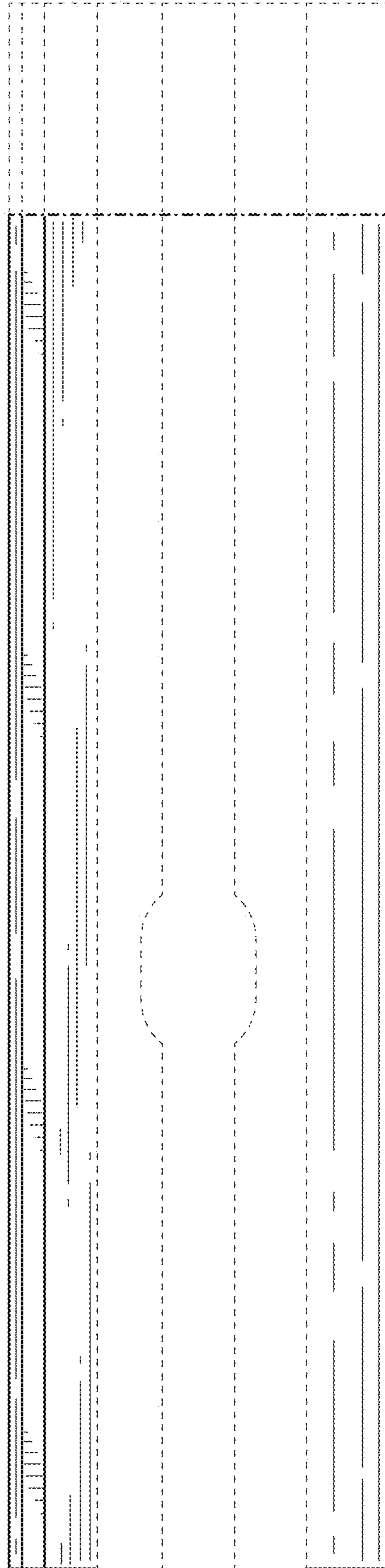

**FIG. 8**