



US00D901953S

(12) **United States Design Patent** (10) **Patent No.:** **US D901,953 S**
McQuary et al. (45) **Date of Patent:** **** Nov. 17, 2020**

(54) **BENCH WITH A CELLO OR GUITAR HOLDER**

D714,561 S * 10/2014 Lange D6/349
D743,707 S * 11/2015 Simitian D6/349
D874,174 S * 2/2020 Krouwel D6/370

(71) Applicant: **CELLO BENCH LLC**, Austin, TX (US)

* cited by examiner

(72) Inventors: **Laura McQuary**, Austin, TX (US);
Jose Minguell, Austin, TX (US)

Primary Examiner — Kelley A Donnelly

(74) *Attorney, Agent, or Firm* — Denko & Bustamante LLP; Sherri Wilson

(73) Assignee: **CELLO BENCH LLC**, Austin, TX (US)

(57) **CLAIM**

The ornamental design for a bench that includes an opening to hold a cello or guitar, as shown and described.

(**) Term: **15 Years**

DESCRIPTION

(21) Appl. No.: **29/704,297**

(22) Filed: **Sep. 4, 2019**

(51) **LOC (12) Cl.** **06-06**

(52) **U.S. Cl.**
USPC **D6/682**

(58) **Field of Classification Search**
USPC D6/349, 370, 680, 682, 682.5, 682.6;
D17/20

CPC A47F 5/0018; A47F 5/16; A47B 19/002;
A47B 23/007; A47B 23/042; A47B 2019/004; G10G 5/00; G10G 5/005;
A47C 1/00; A47C 11/00

See application file for complete search history.

(56) **References Cited**

U.S. PATENT DOCUMENTS

D213,496 S * 3/1969 Wormser D6/349
D229,591 S * 12/1973 Trail et al. D6/370
D342,401 S * 12/1993 Kempton D6/682
D423,239 S * 4/2000 Hornyak D6/355
D465,936 S * 11/2002 Arnold D6/349
D702,065 S * 4/2014 Moore D6/682.4
D713,182 S * 9/2014 Longacre D6/682

FIG. 1 is a front perspective view of the bench, depicted with an opening to hold a guitar;

FIG. 2 is a bottom perspective view of the bench, depicted with an opening to hold a guitar;

FIG. 3 is a front view of the bench, depicted with an opening to hold a guitar;

FIG. 4 is a back view of the bench, depicted with an opening to hold a guitar;

FIG. 5 is a side view of the bench, depicted with an opening to hold a guitar;

FIG. 6 is a side view of the bench, depicted with an opening to hold a guitar;

FIG. 7 is a top view of the bench, depicted with an opening to hold a guitar;

FIG. 8 is a bottom view of the bench, depicted with an opening to hold a guitar;

FIG. 9 is a front perspective view of the bench, depicted with an opening to hold a guitar; and,

FIG. 10 is a front perspective view of the bench, depicted with an opening to hold a cello.

The broken lines shown in the drawings are for illustrative purposes only and form no part of the claimed design.

1 Claim, 4 Drawing Sheets

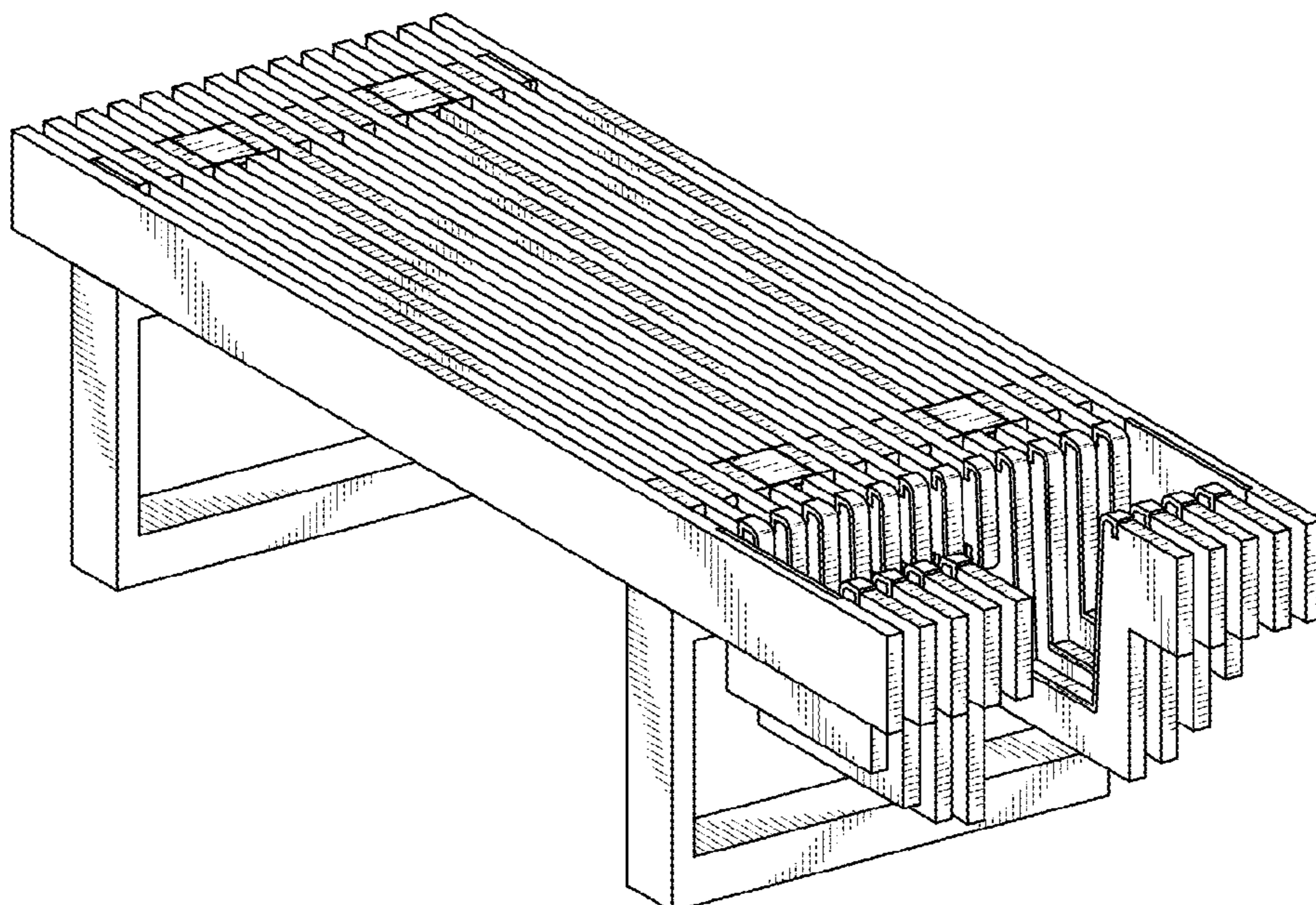

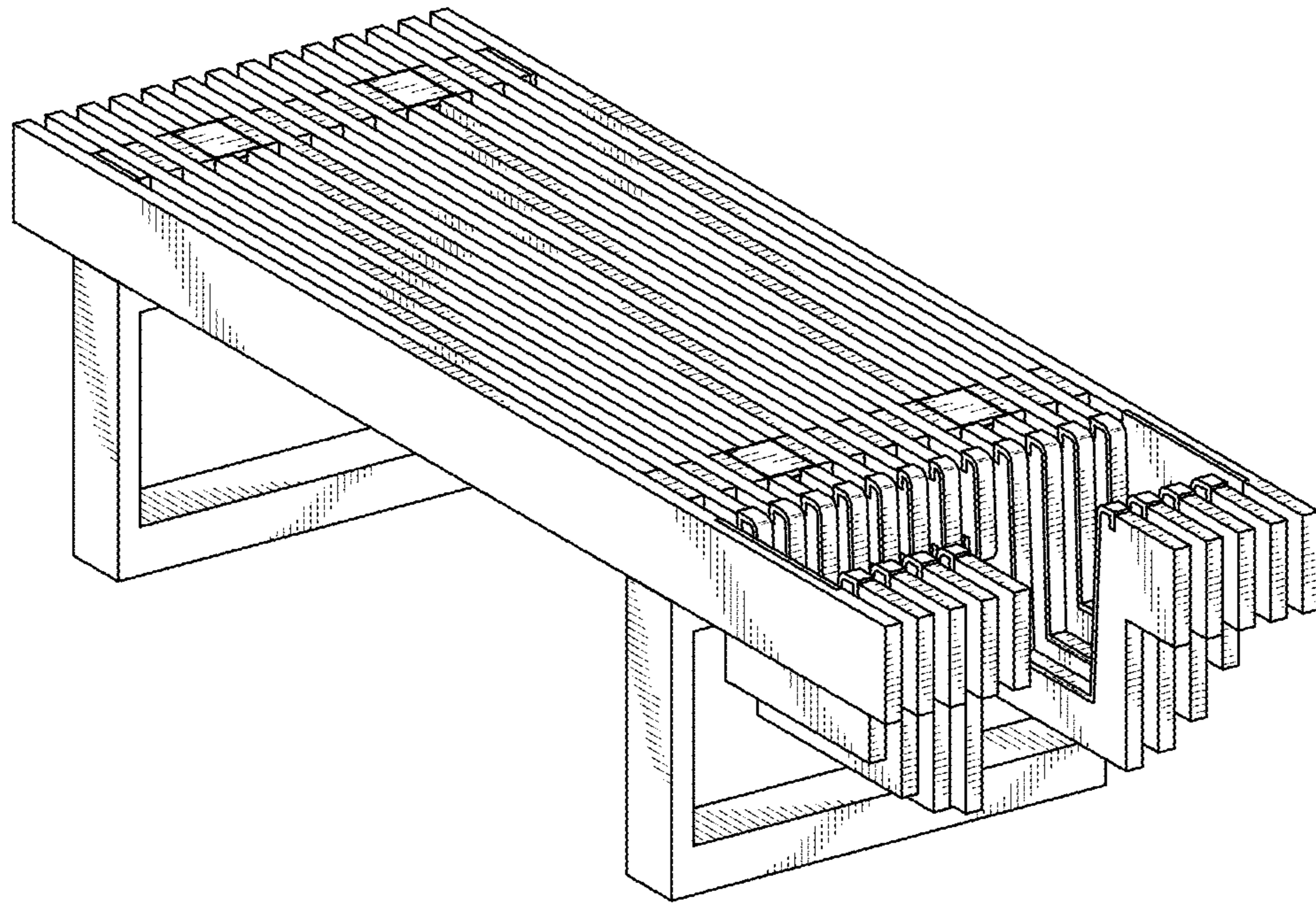

FIG. 1

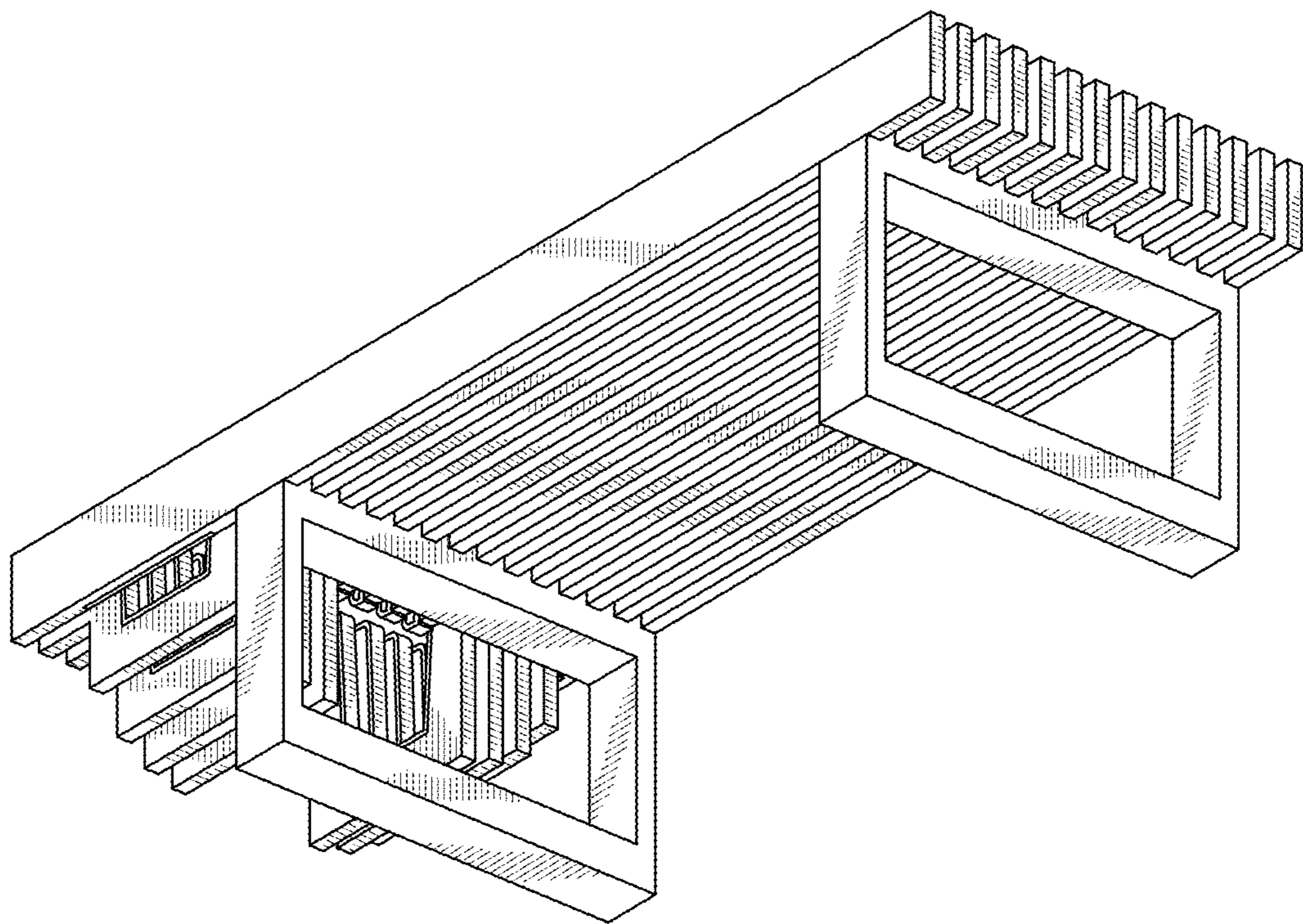

FIG. 2

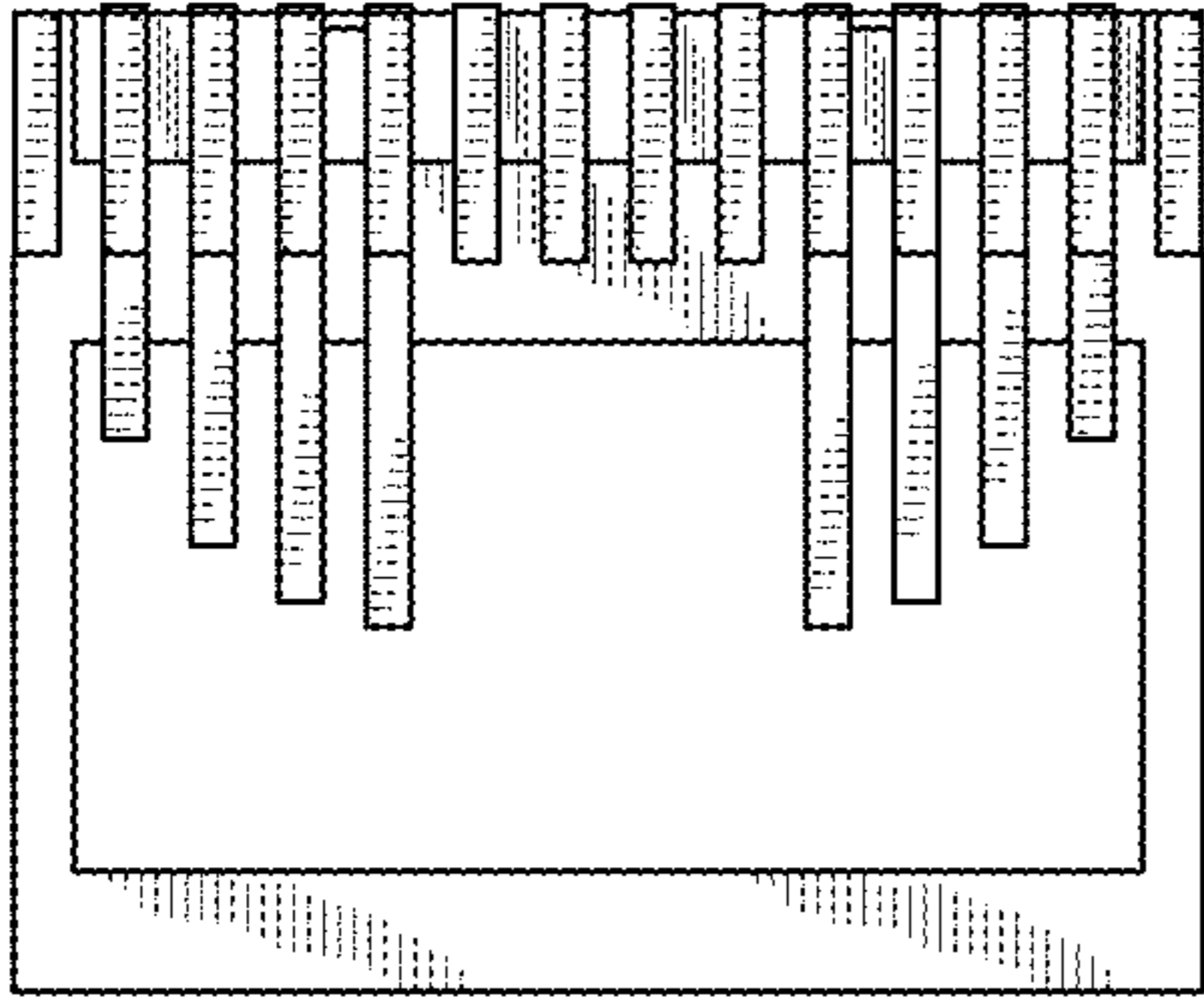

FIG. 3

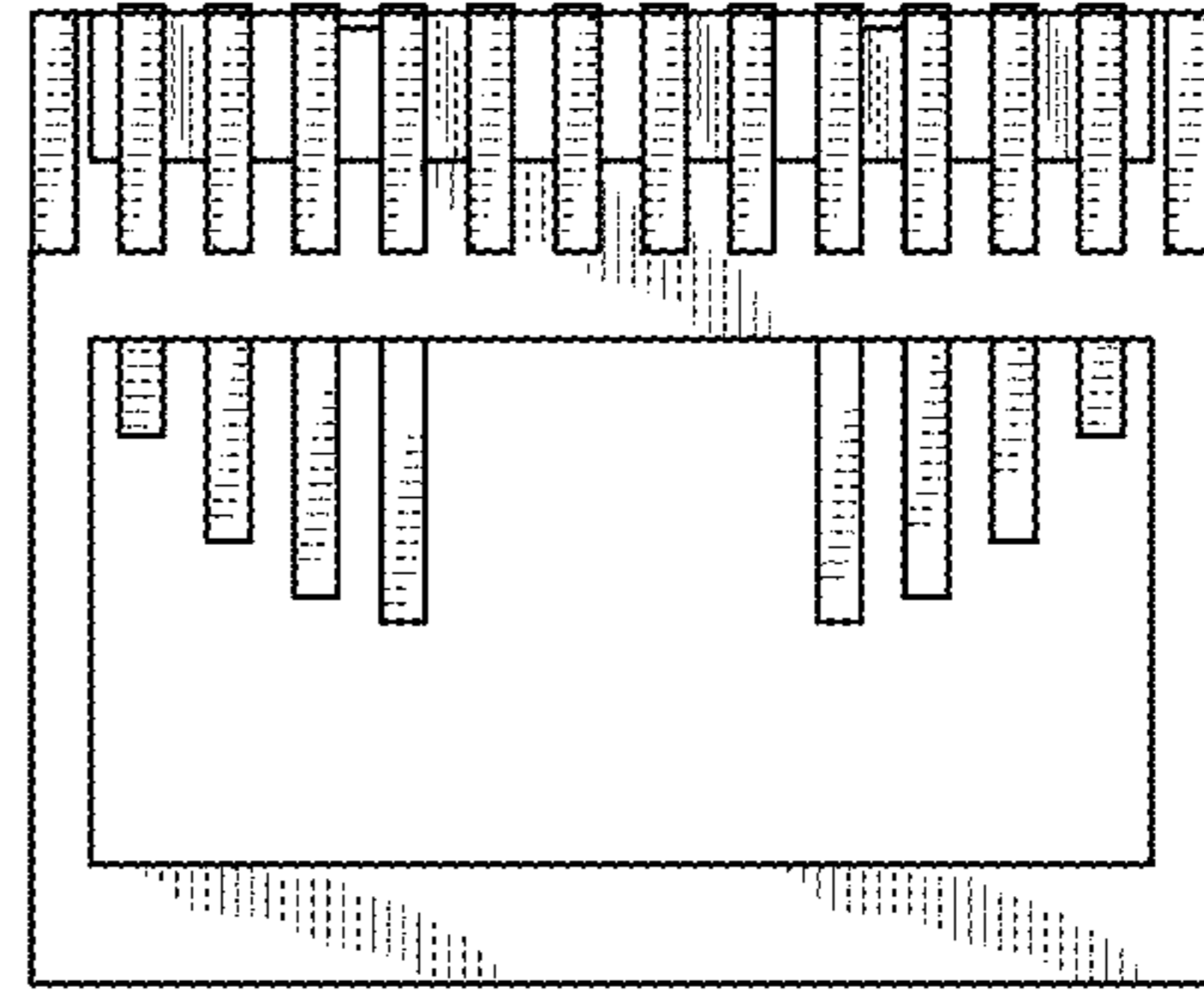

FIG. 4

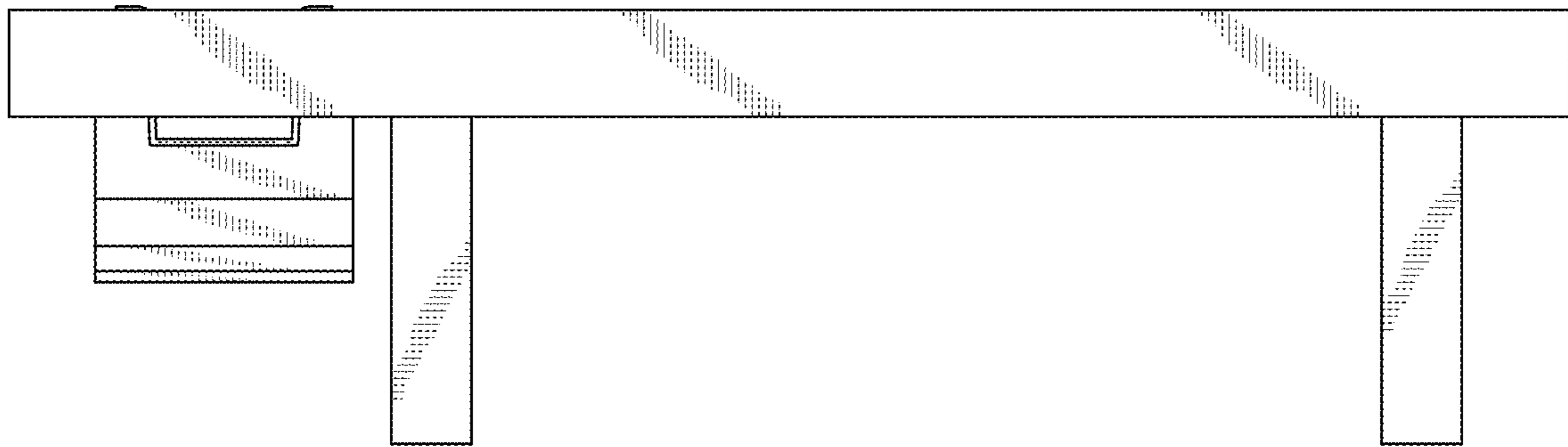

FIG. 5

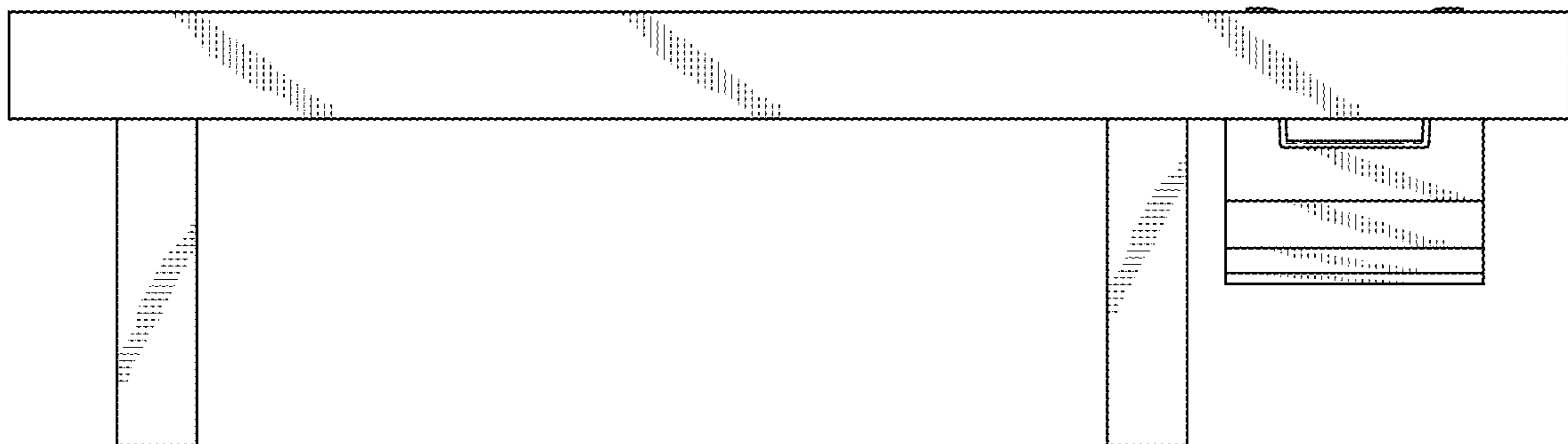

FIG. 6

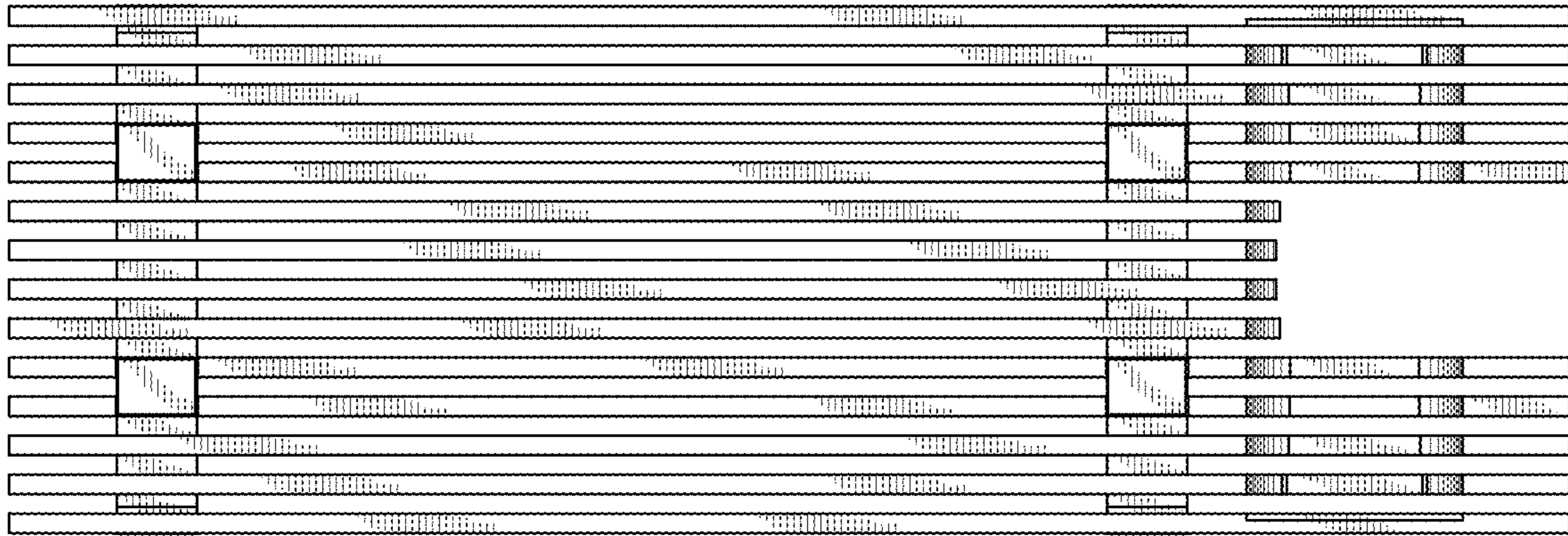

FIG. 7

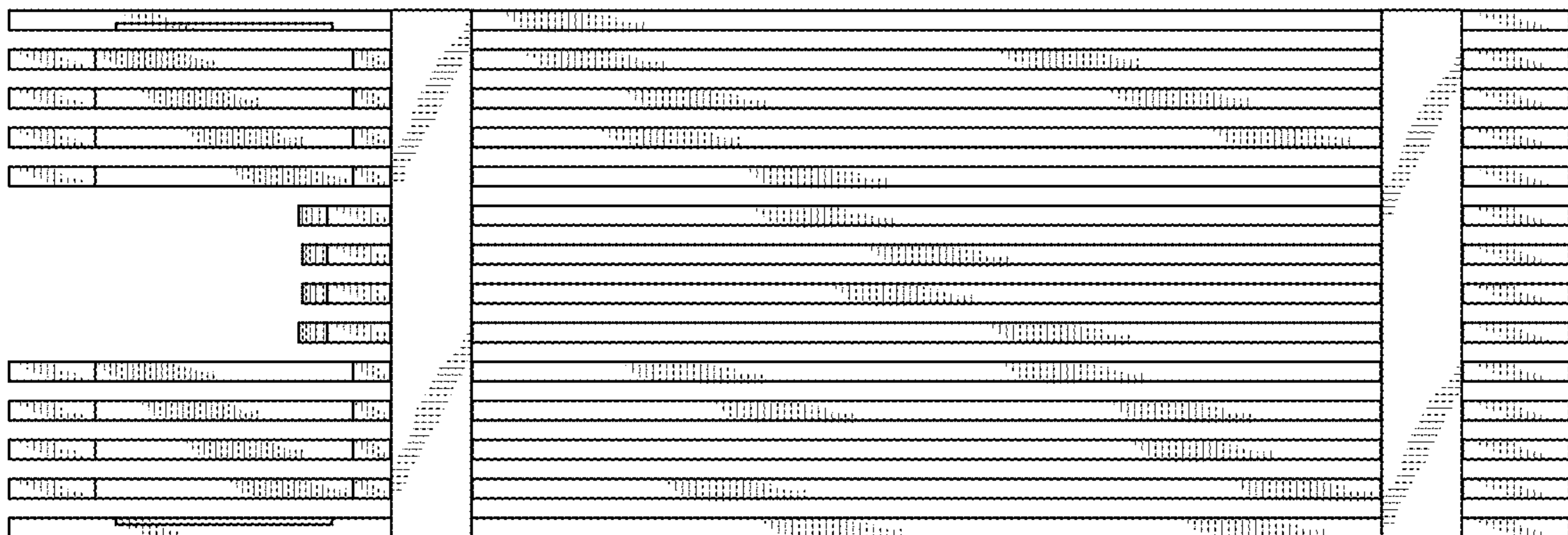

FIG. 8

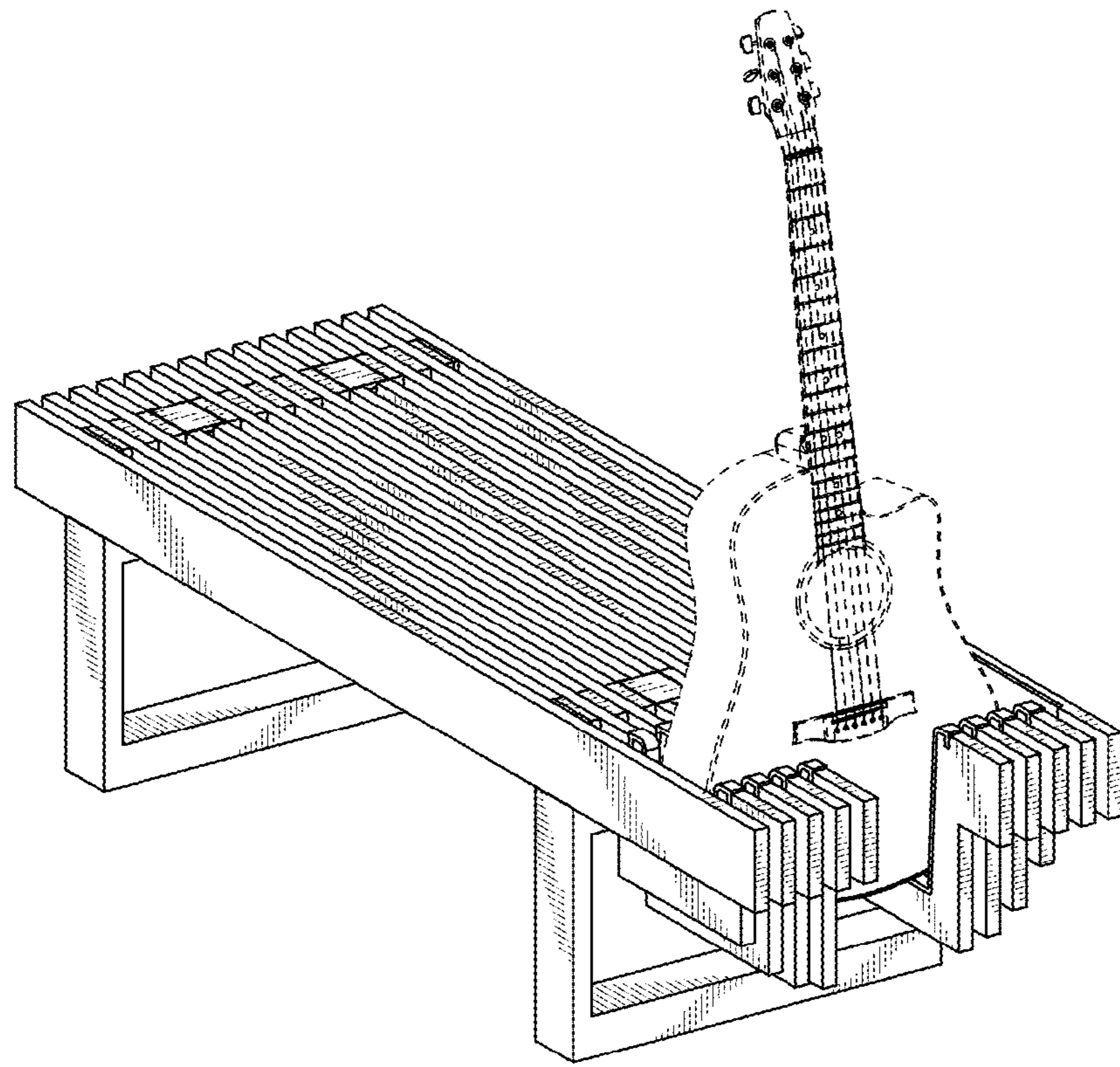

FIG. 9

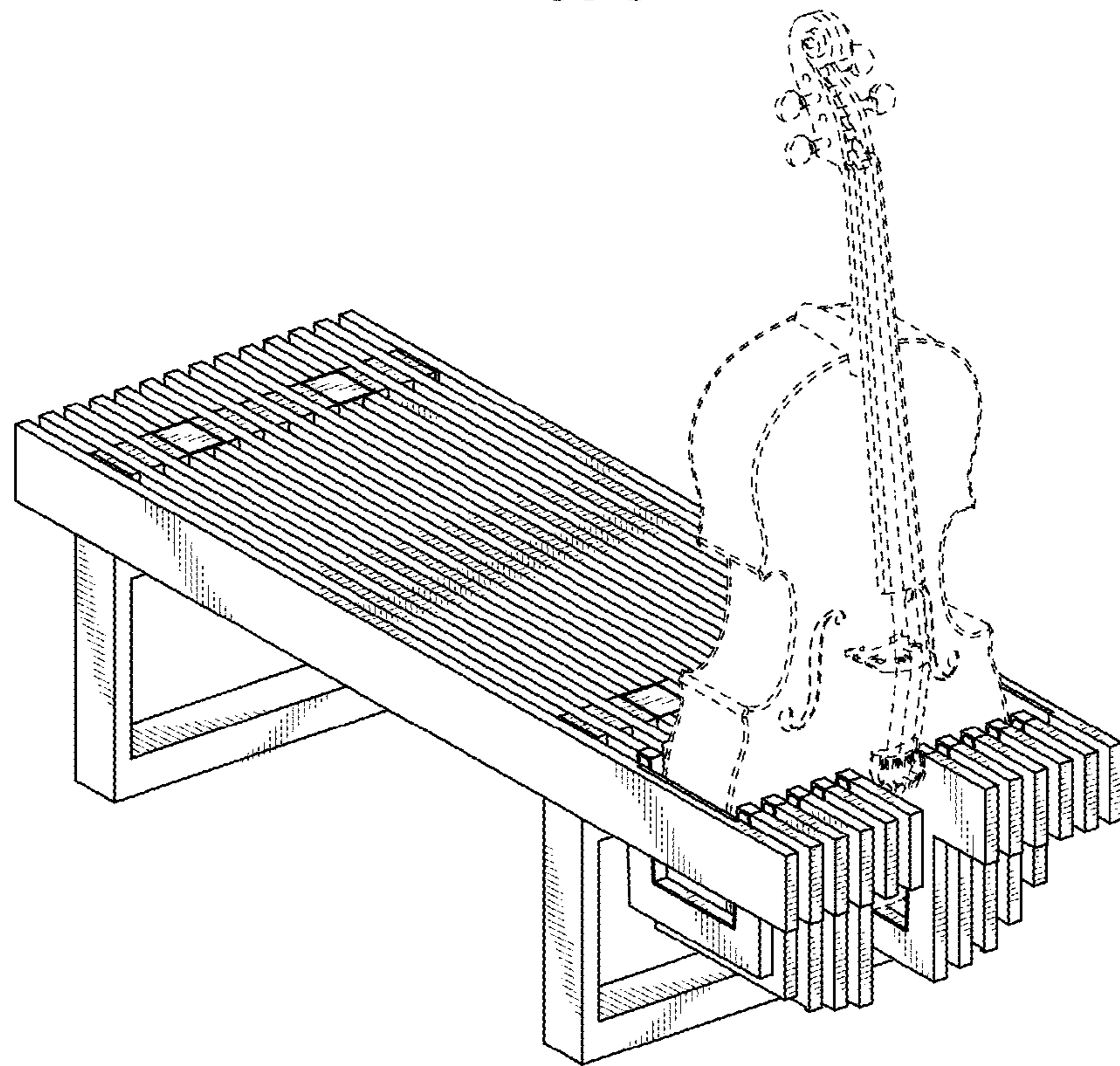

FIG. 10