



US00D901863S

(12) **United States Design Patent** (10) **Patent No.:** **US D901,863 S**
Gavrieli et al. (45) **Date of Patent:** **** Nov. 17, 2020**

- (54) **BLUE SOLE AND MIDSOLE ASSEMBLY FOR SINGLE-SOLE SHOE** 1,214,666 A 2/1917 Ford
1,519,009 A 12/1924 Reina
1,525,848 A * 2/1925 Bonaventure A43B 5/12
36/113
- (71) Applicant: **Gavrieli Brands LLC**, Beverly Hills, CA (US) 1,587,377 A 6/1926 Grosjean
1,650,466 A 11/1927 Righter
2,224,590 A 12/1940 Boivin
- (72) Inventors: **Kfir Gavrieli**, Beverly Hills, CA (US); 2,268,777 A 1/1942 Scholl
Dikla Gavrieli, Beverly Hills, CA (US) D133,819 S * 9/1942 Harris D2/939
D135,791 S 6/1943 Beebe
- (73) Assignee: **Gavrieli Brands LLC**, Beverly Hills, CA (US) 2,323,563 A 7/1943 Nugent
2,342,882 A 2/1944 Meltzer
D141,871 S 7/1945 Braun
2,383,585 A 8/1945 Bindner
- (**) Term: **15 Years** D149,685 S * 5/1948 Sandler D2/935
D150,729 S * 8/1948 Sandler D2/923
D166,090 S * 3/1952 Maling D2/897
- (21) Appl. No.: **29/681,286** 2,772,488 A 12/1956 Meltzer
2,904,814 A 9/1959 Scholl
- (22) Filed: **Feb. 24, 2019** 3,148,378 A 9/1964 Tibbitts
D200,897 S * 4/1965 Mitchell D2/919
D220,464 S 4/1971 Hayoshi
D247,396 S * 3/1978 Schlerth D2/939
4,412,393 A 11/1983 Terlizzi, Jr. et al.

Related U.S. Application Data

- (63) Continuation of application No. 29/657,653, filed on Jul. 24, 2018, now Pat. No. Des. 847,476, which is a continuation of application No. 29/570,760, filed on Jul. 12, 2016, now Pat. No. Des. 824,656, which is a continuation of application No. 29/493,455, filed on Jun. 10, 2014, now Pat. No. Des. 761,539.
- (51) **LOC (12) Cl.** **02-04**
- (52) **U.S. Cl.**
USPC **D2/950**; D2/971
- (58) **Field of Classification Search**
USPC D2/896, 900, 919-921, 925, 939, 947, D2/950, 969, 971
CPC A43B 21/00; A43B 21/02; A43B 21/06; A43B 9/14; A43B 1/0045; A43B 13/10; A43B 13/12; A43B 23/06; A43B 23/07; A43B 1/0036; A43B 5/12
See application file for complete search history.

(56) **References Cited**

U.S. PATENT DOCUMENTS

- | | | | | | |
|-------------|---------|---------------|--------------|---------|------------------|
| 249,086 A | 11/1881 | Pienovi | 6,857,203 B2 | 2/2005 | Minden |
| 773,850 A | 11/1904 | Cooper et al. | 6,895,693 B2 | 5/2005 | Baruck |
| 830,941 A | 9/1906 | Walden | 6,978,557 B2 | 12/2005 | Lee |
| 1,208,209 A | 12/1916 | Prince | 7,032,327 B1 | 4/2006 | Tartaglia et al. |

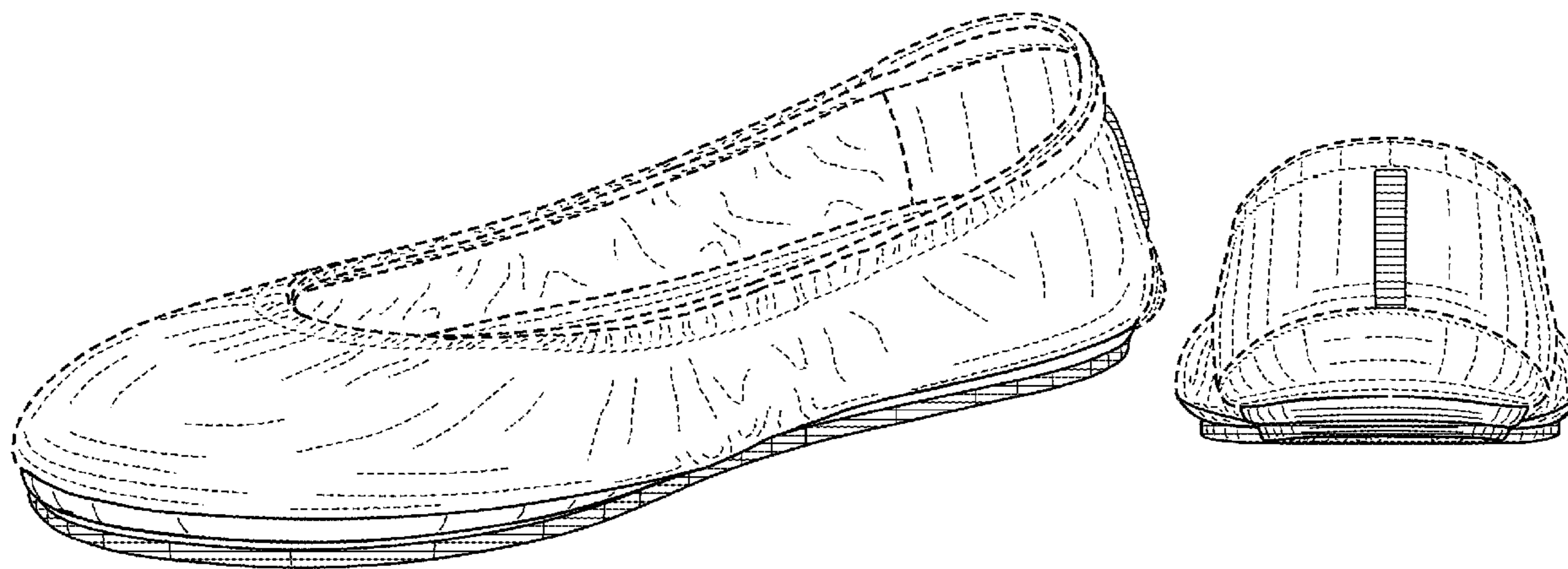

US D901,863 S

Page 2

7,036,244 B1 5/2006 Finch
D527,513 S 9/2006 Della Valle
D529,513 S * 10/2006 Aketa D15/5
D531,790 S 11/2006 Wurzburg
D534,341 S * 1/2007 Choi D2/896
D542,513 S 5/2007 Amado et al.
D556,990 S 12/2007 Cabados
7,337,558 B2 3/2008 Terlizzi et al.
D567,485 S 4/2008 James
D570,488 S 6/2008 Kirksey et al.
D571,084 S 6/2008 Comeau
D571,548 S 6/2008 Seamans
D571,989 S 7/2008 Siegal
D580,640 S 11/2008 Wurzburg
D582,638 S 12/2008 Ringholz
7,496,982 B2 3/2009 Clark et al.
7,506,459 B2 3/2009 Grisoni et al.
D591,031 S 4/2009 Cofinco
D593,295 S * 6/2009 Belley D2/969
D593,297 S * 6/2009 Belley D2/969
D593,307 S * 6/2009 Belley D2/969
D599,093 S * 9/2009 Issler D2/925
D604,030 S 11/2009 Wilson
D607,194 S 1/2010 Zagula
D610,332 S 2/2010 Raichle
D610,785 S 3/2010 Smith
D612,140 S 3/2010 Moon
D612,141 S 3/2010 Moon
7,694,435 B1 4/2010 Kiser et al.
D615,737 S 5/2010 Feller
7,735,244 B1 6/2010 Ameche
7,743,530 B2 6/2010 Truelsen
D618,891 S 7/2010 McClaskie
7,757,408 B2 7/2010 McClaskie
D630,829 S 1/2011 Weisner
D632,881 S 2/2011 Rosenberg
7,926,203 B2 4/2011 Wilkenfeld
7,966,747 B2 6/2011 Wilkenfeld et al.
D640,861 S 7/2011 Wilkenfeld
8,020,320 B2 9/2011 Gillespie
8,127,468 B2 3/2012 Morgan
D657,543 S 4/2012 Bove
D659,960 S 5/2012 Bizzo
8,230,619 B2 7/2012 Salvatelli
D664,755 S 8/2012 Gavrieli et al.
D665,157 S 8/2012 Wu
8,240,067 B2 8/2012 Sussmann
8,245,420 B2 8/2012 Wilson
D668,027 S 10/2012 Millieret
D668,438 S 10/2012 Millieret
D668,847 S * 10/2012 Gavrieli D2/925
D668,848 S * 10/2012 Gavrieli D2/925
D668,849 S 10/2012 Pozzi
D668,850 S 10/2012 Pozzi
D672,542 S 12/2012 Gray et al.
D676,634 S * 2/2013 Gavrieli D2/925
D681,927 S * 5/2013 Gavrieli D2/925
D681,928 S * 5/2013 Gavrieli D2/925
D681,929 S * 5/2013 Gavrieli A43B 13/16
D2/939
D683,936 S * 6/2013 Gavrieli D2/925
8,468,723 B2 6/2013 Malka-Harari
D686,812 S 7/2013 Kfir Gavrieli et al.
8,510,975 B2 8/2013 Krikelis
D688,853 S * 9/2013 Gavrieli A43B 3/108
D2/939
D688,854 S * 9/2013 Gavrieli A43B 13/186
D2/939
D688,855 S * 9/2013 Gavrieli A43B 9/02
D2/939
D689,270 S * 9/2013 Gavrieli A43B 23/0245
D2/939
D689,271 S * 9/2013 Gavrieli A43B 13/14
D2/939
D689,272 S * 9/2013 Gavrieli A43B 3/24
D2/939
D690,914 S * 10/2013 Gavrieli A43B 13/14
D2/939

D690,915 S * 10/2013 Gavrieli A43B 13/14
D2/939
D696,500 S 12/2013 Hunt
D699,424 S 2/2014 Hamm
8,661,714 B2 3/2014 Sussmann
8,745,893 B2 6/2014 Gavrieli et al.
8,973,287 B2 3/2015 Shibata
D761,539 S * 7/2016 Gavrieli D2/950
9,398,786 B2 7/2016 Gavrieli
D782,167 S 3/2017 Gavrieli
D824,150 S * 7/2018 Gavrieli D2/939
D831,312 S 10/2018 Gavrieli
2002/0078591 A1 6/2002 Morrone
2002/0129519 A1 9/2002 Cahan
2003/0070319 A1 4/2003 Minden
2003/0121176 A1 7/2003 Baruck
2004/0025377 A1 2/2004 Brannon
2005/0022421 A1 2/2005 Bruckner
2005/0115115 A1 6/2005 Lacey
2005/0217148 A1 10/2005 Connolly et al.
2005/0262734 A1 12/2005 Cheng
2006/0086005 A1 4/2006 Yerian
2006/0156576 A1 7/2006 Sloan
2007/0074424 A1 4/2007 Lin
2007/0204482 A1 9/2007 Gibson-Collinson
2007/0204483 A1 9/2007 Kirsch et al.
2008/0052964 A1 3/2008 Taylor
2008/0086912 A1 4/2008 Wilkenfeld
2008/0110059 A1 5/2008 Kuramoto et al.
2009/0019732 A1 1/2009 Sussmann
2009/0193685 A1 8/2009 Wilson
2009/0205222 A1 8/2009 Mclinden
2009/0272009 A1 11/2009 Weisner et al.
2010/0011625 A1 1/2010 Percival
2010/0018080 A1 1/2010 Smith
2010/0050469 A1 3/2010 Chen
2010/0095557 A1 4/2010 Jarvis
2010/0115793 A1 5/2010 Kraisosky
2010/0122475 A1 5/2010 Purrington
2010/0146822 A1 6/2010 MacGregor
2010/0212186 A1 8/2010 Cheng
2010/0275462 A1 11/2010 Pucci
2010/0281713 A1 11/2010 Pantazes
2015/0089843 A1 4/2015 Gavrieli

FOREIGN PATENT DOCUMENTS

DE	20 2006 000230	U1	5/2007
GB	2443937	A	5/2008
GB	2 446 205	A	8/2008
TW	D119165		10/2007

OTHER PUBLICATIONS

Examination Report for AU 341324, 3 pgs., dated Oct. 24, 2012.
Letter from TMI and Associates with Office Action, 2 pgs, dated Sep. 19, 2012 <http://www.payless.com/store/?&TLC=Womens&SLC=WomensNewArrivals&BLC=WomensNewArrivalsNewArrivals&With+Regular&ItemCode=60131&LotNumber=062642&Type=Adult&Popularity=637&Descriptvein>.
Taiwanese Office Action for TW 101300726, 10 pgs., dated Sep. 6, 2012.
“The Love List, Tiefs by Gavrieli—Foldable Ballet Flats,” <http://thelovelist-carly.blogspot.com.au/2010/09/tiefs-by-gavriell-foldable-ballet.html>, 2 pgs., Sep. 12, 2010.
“Tiefs by Gavrieli,” <http://tiefs.com>, 1 pg., retrieved Mar. 13, 2013 from URL.
“Try It Mummy!, Tiefs by Gavrieli,” <http://tryitmummy.blogspot.com.au/2010/12/tiefs-by-gavriell.html>, 3 pgs., Dec. 9, 2010.
“Wearability—Real People Style, What came first, the City Flat or the Tiefs,” <http://wearability.posterous.com/what-came-first-the-city-flat-or-the-tiefs>, 2 pgs., Aug. 29, 2010.
“The Ballet Flat . . . Reinvented; Ballet Flats . . . with a Bonus; Step Into Tiefs; Going Places? Take Tiefs,” <http://web.archive.org/web/2010052004346/http://www.tiefs.com/>; 4 pgs., May 24, 2010.

- “Tieks—Comfortable designer flats you can fit in your purse and wear all day, every day,” <http://web.archive.org/web/20110731151555/http://tieks.com/>; 6 pgs., Jul. 31, 2011.
- “58th Annual Emmy Awards,” http://spoonsforksandfashion.blogspot.com/2006_08_01_archive.html, depicting Nine West flats, 2 pgs., Aug. 1, 2006.
- Pictures of Nine West flats sold in 2006, 3 pgs.
- “I Love a Good Ballet Flat!,” <http://dressupfiles.com/i-love-a-good-ballet-flat>, depicting Sue London flats, 3 pgs., Sep. 3, 2010.
- Pictures of Sue London flats sold in 2010, 2 pgs.
- “Miss Cathie Reviews: The Yosi Samra Foldable Ballet Flat . . .,” <http://www.misscathie.com/2010/01/miss-cathie-reviews-the-yosi-samra-foldable-ballet-flat/>, depicting Yosi Samra flats, 9 pgs., Jan. 2010.
- Pictures of Yosi Samra flats sold in 2010, 2 pgs.
- “Goodbye two thousand ten,” http://emmajoyrussell.blogspot.com/2010_12_01_archive.html, depicting Gap flats, 39 pgs., Dec. 1, 2010.
- Pictures of Gap flats available for sale in 2010, 9 pgs.
- “Our newest design of folding flats-Pink,” <https://fitinclouds.wordpress.com/2010/05/16/our-newest-design-of-folding-flats-pink/>, depicting Fit in Clouds flats, 1 pg., May 16, 2010.
- “Fit in Clouds Satin Folding Shoes,” <http://www.goodhousekeeping.com/product-reviews/clothing/best/ballet-flats/fit-in-clouds-satin-foldable-ballet-flats>, depicting Fit in Clouds flats, 2 pg., Aug. 2013.
- Pictures of Fit in Clouds flats available for sale in 2011, 4 pgs.
- “Shoes for Standing,” <https://truthinshoes.wordpress.com/2008/07/>, depicting Sam & Libby flats, 2 pgs., Jul. 31, 2008.
- “Target Designer Collaboration: Announcing Sam & Libby Shoes for Target,” <http://www.therecessionista.com/2012/11/target-designer-collaboration-announcing-sam-libby-shoes-for-target.html>, depicting Sam & Libby flats, 1 pg., Nov. 26, 2012.
- Pictures of Sam & Libby flats available for purchase in 2011, 5 pgs.
- “Save your soles with Citisoles ballet flats,” <http://glamazondiaries.com/2009/07/save-your-soles-with-citisoles-ballet-flats>, depicting Citisoles flats, 3 pgs., Jul. 2009.
- Pictures of Citisoles flats available for purchase in 2009, 3 pgs.
- “#16 Corso Como Delicious Pumps Review and Giveaway!,” <http://www.mommatoldmeblog.com/2011/01/16-corso-como-delicious-pumps-review.html>, depicting Corso Como flats, 8 pgs., Jan. 16, 2011.
- Pictures of Corso Como flats available for sale in 2011, 3 pgs.
- “Jil-sander-navy-lead-ballet-flats-product . . .,” www.ebay.com, depicting Jil Sander flats, 4 pgs., Nov. 2013.
- Pictures of Jil Sander flats available for sale in 2011, 3 pgs.
- “Spare Soles: Shoes That Roll-up & Fold-up,” <http://herpackinglist.com/2011/01/spare-soles-shoes/>, depicting Spare Soles flats, 2 pgs., Jan. 2011.
- Pictures of Spare Soles flats available for sale in 2011, 5 pgs.
- Pictures of Roll-Uppz by Spare Soles flats available for sale in 2011, 6 pgs.
- “The Cutest Blog, Preppy 50 and Loving Lilly, Ballet Flat Delight,” <http://preppy50andlovinglilly.blogspot.com/2011/02/ballet-flat-delight.html>, depicting Henri Bendel flats, 1 pg., Feb. 19, 2011.
- Pictures of Henri Bendel flats available for sale in 2011, 4 pgs.
- “Mumsnet by parents for parents,” http://www.mumsnet.com/Talk/style_and_beauty/a1612000-Anyone-tried-Redfoot-Flatmates-foldable-ballet-pumps, depicting Redfoot Flatmates flats, 1 pg, Nov. 14, 2012.
- Pictures of Redfoot Flatmates flats available for sale in 2011, 6 pgs.
- “Amazon.com: Customer Reviews: Bloch London Women’s Lux Ballet Flat,” <http://www.amazon.com/Bloch-London-Womens-Ballet-Flat/product-reviews/B004LWP7YW>, depicting Bloch London flats, 4 pgs., Dec. 11, 2011.
- Pictures of Bloch London flats offered for sale in 2011, 11 pgs.
- “h&m foldable leopard print flat,” <https://8485shops.wordpress.com/2011/06/16/flats-for-7-bucks/shoe1/>, depicting h&m flats, 2 pgs., Jun. 16, 2011.
- Pictures of h&m foldable flats offered for sale in 2011, 4 pgs.
- “Seekyt—Juicy Couture Ballet Flats—Are They Worth The Money?,” <http://seekyt.com/juicy-couture-ballet-flats-are-they-worth-the-money/>, 2 pgs., Jun. 3, 2011.
- Pictures of Juicy Couture flats offered for sale in 2011, 3 pgs.
- “Purse Flats,” <http://purseflats.wordpress.com>, depicting Purse Flats by Erica Wilson, 3 pgs., Jul. 12, 2012.
- Pictures of Purse Flats by Erica Wilson offered for sale in 2011, 6 pgs.
- “Tieks by Gavrieli—Comfortable, designer flats you can fit in your purse and wear all day . . .,” <http://web.archive.org/web/20110202210649/http://www.tieks.com/>, 8 pgs., Feb. 2, 2011.
- “Carolina M. M. Goncalves > Tieks by Gavrieli,” http://m2.facebook.com/Tieks?v=timeline&filter=2&timecutoff=1406427986&page=17§ionLoadingID=m_timeline_loading_div_1293868799_1262332800_8_17&timeend=1293868799×tart=1262332800&tm=AQDOvghWQP_Nbwm&refid=17, 1 pg. Jan. 26, 2010.
- “The Shoes Oprah Would Wear to Work (if She Had to Walk),” <http://www.inc.com/30under30/christina-desmarais/kfir-gavrieli-and-elram-gavrieli-founders-of-tieks.html>, 2 pgs., Jul. 2, 2012.
- “Tieks by Gavrieli,” http://m2.facebook.com/Tieks?v=timeline&filter=2&timecutoff=1406427986&page=14§ionLoadingID=m_timeline_loading_div_1293868799_1262332800_8_14&timeend=1293868799×tart=1262332800&tm=AQDOvghWQP_Nbwm&refid=17, 4 pgs., Jan. 26, 2010.
- “Mighty Life List, Sensible Shoes,” <http://mightygirl.com/2010/08/24/sensible-shoes/>, 11 pgs., Aug. 24, 2010.
- “Find! Tieks: Fab & sexy flats for fall,” <http://thefabmom.com/2013/08/29/find-tieks-fab-sexy-flats-for-fall/>, 3 pgs. Aug. 29, 2013.
- “Step into Tieks,” <http://sliceofpink.typepad.com/blog/2010/09/tieks-1.html>, 5 pgs., Sep. 22, 2010.
- “In Need of Flat-Soled Shoes,” <http://www.kellywickham.com/mochamomma/2010/10/4/in-need-of-flat-soled-shoes.html>, 4 pgs., Oct. 3, 2010.
- “Say Hello to the Flat Shoes You Need for Fall . . . All 88 of Them!”, Picture of Adam Tucker Shoe/Slipper, <https://www.facebook.com/search/top/?q=adam%20shoes%20slipper>, last accessed Oct. 28, 2016, dated Oct. 1, 2013, 1 page.
- Picture of Adam Tucker Rainbow Shoes, <https://www.facebook.com/search/top/?q=adam%20shoes%20rainbow>, last accessed Oct. 28, 2016, dated Aug. 14, 2013, 1 page.
- Third Party Submission Under 37 CFR 1.290 regarding U.S. Appl. No. 15/905,239, Feb. 9, 2019, 94 pages.
- Order Granting TRO (D.I. 11), *Gavrieli Brands LLC vs. Soto Massini*, Civil Action No. 1:18-cv-00462, Mar. 28, 2018, 2 pages.
- Defendants’ Opposition To Motion For Temporary Restraining Order, Civil Action No. 1:18-cv-00462-GMS, Apr. 1, 2018, 12 pages.
- Declaration of Thomas Pichler In Opposition To Tro Request, C.A. No. 1:18-cv-00462-GMS, Apr. 1, 2018, 8 pages.
- Exhibit A to Pichler Declaration ISO TRO Opposition (D.I. 13-1), C.A. No. 1:18-cv-00462-GMS, Apr. 1, 2018, 29 pages.
- Order TRO (D.I. 18), C.A. No. 1:18, Apr. 4, 2018, 3 pages.
- Defendant Soto Massini (USA) Corporation’s Answer and Counterclaims To Verified Complaint for Patent Infringement, Trade Dress Infringement, and Unfair Competition, C.A. No. 1:18-cv-00462-GMS, May 1, 2018, 26 pages.
- Defendant Soto Massini (USA) Corporation’s Answer To Amended Complaint and Amended Counterclaims, C.A. No. 1:18-cv-00462-GMS, Jun. 5, 2018, 28 pages.
- Defendant Soto Massini (USA) Corporation’s Answer To Amended Complaint and First Amended Counterclaims, C.A. No. 1:18-cv-00462-GMS, Jul. 12, 2018, 31 pages.
- Exhibit A to SACC (45-1), Case 1:18-cv-00462-GMS, 3 pages.
- Exhibit B to SACC (45-2), Case 1:18-cv-00462-GMS, 5 pages.
- Exhibit C to SACC (45-3), Case 1:18-cv-00462-GMS, 5 pages.
- Exhibit D to SACC (45-4), Case 1:18-cv-00462-GMS, 4 pages.
- Defendant Soto-USA’s Invalidity Contentions, C.A. No. 1:18-cv-00462-MN, 16 pages.
- Redacted Verdict Form (D.I. 144), Case 1:18-cv-00462-GMS, 13 pages.
- Judgement (D.I. 149), C.A. No. 18-462-MN, May 13, 2019, 3 pages.
- Gavrieli Brands, LLC, v. Soto Massini (USA) Corp., et al.*, (full) Trial Transcript, C.A. No. 18-462(MN), vol. 1, 733 pages.
- Expert Report of Caroline de Baere (Fed. R. CIV. P. 26(a)(2)(B)), Case No. 18-cv-00462-MN, Mar. 1, 2019, 33 pages.

Exhibit 23, Infringement Analysis in Light of the Alleged Prior Art, 41 pages.
 Expert Report of Lance Rake, (Fed. R. CIV. P. 26(a)(2)(B), Mar. 1, 2019, 27 pages.
 U.S. Pat. No. 1,525,848, Feb. 10, 1925, B. S. Bonaventure, 3 pages.
 Design U.S. Pat. No. 247,396, Mar. 7, 1978, William A. Schlerth, 2 pages.
 Design U.S. Pat. No. D611,693 S, Mar. 16, 2010, Barbara Schwartz, 7 pages.
 Camper Book Excerpt—Nina Right, (pp. 334-335), The Walking Society, Lars Müller Publishers, 3 pages.
 Camper History—The Shoes, Every Season We Strive To Reinvent Some Of Our Classic Concepts While Continuing To Challenge The Status Quo With New And Original Designs. We Often Find That There Is A Camper Style For Every Walk Of Life, 8 pages.
 Tiefs by Gavrieli—Comfortable, designer flats you can fit in your purse and wear all day, every day!, Copperhead Snake Print Tiefs, <https://web.archive.org/web/20101230062534/http://www.tiefs.com:80/>, Dec. 30, 2010, 1 page.
 Tiefs by Gavrieli—Comfortable, designer flats you can fit in your purse and wear all day, every day!, Merlot Lizard Print Tiefs, <https://web.archive.org/web/20101230062534/http://www.tiefs.com:80/>, Dec. 30, 2010, 1 page.
 Tiefs by Gavrieli—Comfortable, designer flats you can fit in your purse and wear all day, every day!, Slate Grey Tiefs, <https://web.archive.org/web/20101230062534/http://www.tiefs.com:80/>, Dec. 30, 2010, 1 page.
 Tiefs by Gavrieli—Comfortable, designer flats you can fit in your purse and wear all day, every day!, Camel, <https://web.archive.org/web/20101230062534/http://www.tiefs.com:80/>, Dec. 30, 2010, 1 page.
 Tiefs by Gavrieli—Comfortable, designer flats you can fit in your purse and wear all day, every day!, Lilac, <https://web.archive.org/web/20101230062534/http://www.tiefs.com:80/>, Dec. 30, 2010, 1 page.
 Tiefs by Gavrieli—Comfortable, designer flats you can fit in your purse and wear all day, every day!, Leopard Print, <https://web.archive.org/web/20101230062534/http://www.tiefs.com:80/>, Dec. 30, 2010, 1 page.
 Tiefs by Gavrieli—Comfortable, designer flats you can fit in your purse and wear all day, every day!, The Tiefs eGift card . . . Always the perfect fit, <https://web.archive.org/web/20101230062534/http://www.tiefs.com:80/>, Dec. 30, 2010, 1 page.
 Tiefs by Gavrieli—Comfortable, designer flats you can fit in your purse and wear all day, every day!, Copperhead Snake Print, <https://web.archive.org/web/20110222174850/http://www.tiefs.com:80/>, Feb. 22, 2011, 1 page.
 Tiefs by Gavrieli—Comfortable, designer flats you can fit in your purse and wear all day, every day!, Patent Tiek Blue, <https://web.archive.org/web/20110222174850/http://www.tiefs.com:80/>, Feb. 22, 2011, 1 page.
 Tiefs by Gavrieli—Comfortable, designer flats you can fit in your purse and wear all day, every day!, Tangerine, <https://web.archive.org/web/20110222174850/http://www.tiefs.com:80/>, Feb. 22, 2011, 1 page.
 Tiefs by Gavrieli—Fashionable Flats That Fit in Your Purse California Navy, <https://web.archive.org/web/20100516173039/http://www.tiefs.com:80/california-navy.html>, May 16, 2010, 1 page.
 Tiefs by Gavrieli—Fashionable Flats That Fit in Your Purse Cardinal Red, <https://web.archive.org/web/20100516173045/http://www.tiefs.com:80/cardinal-red.html>, May 16, 2010, 1 page.
 Tiefs by Gavrieli—Fashionable Flats That Fit in Your Purse Metallic Gold, <https://web.archive.org/web/20100516173106/tiefs.com/metallic-gold.html>, May 16, 2010, 1 page.
 Tiefs by Gavrieli—Fashionable Flats That Fit in Your Purse Patent Tiek Blue, <https://web.archive.org/web/20100516173130/http://www.tiefs.com:80/tiek-blue.html>, May 16, 2010, 1 page.
 Tiefs by Gavrieli—Fashionable Flats That Fit in Your Purse Splash Page, The Ballet Flat . . . Reinvented, <https://web.archive.org/web/20100513055818/https://tiefs.com/>, May 13, 2010, 1 page.
 Tiefs by Gavrieli—Fashionable Flats That Fit in Your Purse Splash Page, Ballet Flats . . . with a Bonus, <https://web.archive.org/web/20100513055818/https://tiefs.com/>, May 13, 2010, 1 page.

Tiefs by Gavrieli—Fashionable Flats That Fit in Your Purse Splash Page, Going Places? Take Tiefs, <https://web.archive.org/web/20100513055818/https://tiefs.com/>, May 13, 2010, 1 page.
 Tiefs by Gavrieli—Fashionable Flats That Fit in Your Purse Splash Page, Step Into Tiefs, <https://web.archive.org/web/20100513055818/https://tiefs.com/>, May 13, 2010, 1 page.
 Tiefs by Gavrieli—Fashionable Flats That Fit in Your Purse True Blue, <https://web.archive.org/web/20100516173135/http://www.tiefs.com:80/true-blue.html>, May 16, 2010, 1 page.
 Tiefs by Gavrieli—Fashionable Flats That Fit in Your Purse White Croc Print, <https://web.archive.org/web/20100516173145/http://www.tiefs.com:80/white-croc-print.html>, May 16, 2010, 1 page.
 Tiefs by Gavrieli—Foldable Fashionable Ballet Flats, Wild Copper, Be a little wild . . . even when you're not., <https://web.archive.org/web/20100819165503/https://tiefs.com/>, Aug. 19, 2010, 1 page.
 Tiefs by Gavrieli—Foldable Fashionable Ballet Flats, Paradise Blue, The perfect pair for day and night, <https://web.archive.org/web/20100819165503/https://tiefs.com/>, Aug. 19, 2010, 1 page.
 Tiefs by Gavrieli—Foldable Fashionable Ballet Flats, Obsidian Black, When workdays spill over into party nights., <https://web.archive.org/web/20100819165503/https://tiefs.com/>, Aug. 19, 2010, 1 page.
 Tiefs by Gavrieli—Foldable Fashionable Ballet Flats, Fuchsia, Sweet and sultry, <https://web.archive.org/web/20100819165503/https://tiefs.com/>, Aug. 19, 2010, 1 page.
 Tiefs by Gavrieli—Foldable Fashionable Ballet Flats, Tan Croc print Tiefs, A timeless texture., <https://web.archive.org/web/20100819165503/https://tiefs.com/>, Aug. 19, 2010, 1 page.
 Tiefs by Gavrieli—Foldable Fashionable Ballet Flats, Be a little wild . . . even when you're not., <https://web.archive.org/web/20100902020755/https://tiefs.com/>, Sep. 2, 2010, 1 page.
 Tiefs by Gavrieli—Foldable Fashionable Ballet Flats, Obsidian Black, When workdays spill over into party nights. <https://web.archive.org/web/20100902020755/https://tiefs.com/>, Sep. 2, 2010, 1 page.
 Tiefs by Gavrieli—Foldable Fashionable Ballet Flats, Tan Croc Print, A timeless texture, <https://web.archive.org/web/20100902020755/https://tiefs.com/>, Sep. 2, 2010, 1 page.
 Tiefs by Gavrieli—Foldable Fashionable Ballet Flats, Paradise Blue, The perfect pair for day and night, <https://web.archive.org/web/20100902020755/https://tiefs.com/>, Sep. 2, 2010, 1 page.
 Tiefs by Gavrieli—Foldable Fashionable Ballet Flats, Fuchsia, Sweet and sultry, <https://web.archive.org/web/20100902020755/https://tiefs.com/>, Sep. 2, 2010, 1 page.
 Tiefs by Gavrieli—Foldable Fashionable Ballet Flats, Tiek Blue Tiefs, Let yourself shine, <https://web.archive.org/web/20100902020755/https://tiefs.com/>, Sep. 2, 2010, 1 page.

* cited by examiner

Primary Examiner — Dominic V Simone
 (74) Attorney, Agent, or Firm — Morgan, Lewis & Bockius LLP

(57) CLAIM

The ornamental design for a blue sole and midsole assembly for a single-sole shoe, as shown and described.

DESCRIPTION

The file of this patent contains at least one drawing executed in color. Copies of this patent with color drawing(s) will be provided by the Office upon request and payment of the necessary fee.

FIG. 1 is a perspective view of our new design of a blue sole and midsole assembly for a single-sole shoe, where the blue portions are indicated using the USPTO convention of horizontal lines for blue to indicate the blue color including any one of Pantone 277-Pantone 313, any one of Pantone 317-Pantone 320, any one of Pantone 325-Pantone 330, any

one of Pantone 332-336, any one of Pantone 628-Pantone 662, Pantone 801, Pantone 808, any one of Pantone 2702-Pantone 2708, any one of Pantone 2717-Pantone 2718, Pantone 2727 and Pantone 2728, Pantone 2747 and Pantone 2748, Pantone 2757 and Pantone 2758, Pantone 2767 and Pantone 2768, any one of Pantone 2906-Pantone 2995, any one of Pantone 3005-Pantone 3165, any one of Pantone 3242-Pantone 3254, anyone of Pantone 3256-Pantone 3278, any one of Pantone 5395-Pantone 5435, any one of Pantone 7453-Pantone 7465, any one of Pantone 7467-Pantone 7477, any one of Pantone 7541-Pantone 7547, any one of RAL 5016-RAL 5002, any one of RAL 5004-RAL 5014, or any one of RAL 5016-RAL 5026;

FIG. 2 is a first side view of the design of FIG. 1;
 FIG. 3 is a second side view of the design of FIG. 1;
 FIG. 4 is a top view of the design of FIG. 1;
 FIG. 5 is a bottom view of the design of FIG. 1;
 FIG. 6 is a front view of the design of FIG. 1;
 FIG. 7 is a back view of the design of FIG. 1;
 FIG. 8 is a perspective view of another embodiment of our new design of a blue sole and midsole assembly for single-sole shoe, where the blue portions indicate the blue color Pantone 293;
 FIG. 9 is a first side view of the design of FIG. 1;
 FIG. 10 is a second side view of the design of FIG. 1;
 FIG. 11 is a top view of the design of FIG. 1;
 FIG. 12 is a bottom view of the design of FIG. 1;
 FIG. 13 is a front view of the design of FIG. 1;
 FIG. 14 is a back view of the design of FIG. 1;
 FIG. 15 is a perspective view of yet another embodiment our new design of a blue sole and midsole assembly for single-sole shoe, where the blue portions indicate the blue color Pantone 314;
 FIG. 16 is a first side view of the design of FIG. 15;
 FIG. 17 is a second side view of the design of FIG. 15;
 FIG. 18 is a top view of the design of FIG. 15;
 FIG. 19 is a bottom view of the design of FIG. 15;
 FIG. 20 is a front view of the design of FIG. 15;
 FIG. 21 is a back view of the design of FIG. 15;
 FIG. 22 is a perspective view of yet another embodiment our new design of a blue sole and midsole assembly for single-sole shoe, where the blue portions indicate the blue color Pantone 331;
 FIG. 23 is a first side view of the design of FIG. 22;
 FIG. 24 is a second side view of the design of FIG. 22;
 FIG. 25 is a top view of the design of FIG. 22;
 FIG. 26 is a bottom view of the design of FIG. 22;
 FIG. 27 is a front view of the design of FIG. 22;
 FIG. 28 is a back view of the design of FIG. 22;
 FIG. 29 is a perspective view of yet another embodiment our new design of a blue sole and midsole assembly for single-sole shoe, where the blue portions indicate the blue color Pantone 644;
 FIG. 30 is a first side view of the design of FIG. 29;
 FIG. 31 is a second side view of the design of FIG. 29;
 FIG. 32 is a top view of the design of FIG. 29;
 FIG. 33 is a bottom view of the design of FIG. 29;

FIG. 34 is a front view of the design of FIG. 29;
 FIG. 35 is a back view of the design of FIG. 29;
 FIG. 36 is a perspective view of yet another embodiment our new design of a blue sole and midsole assembly for single-sole shoe, where the blue portions indicate the blue color Pantone 2905;
 FIG. 37 is a first side view of the design of FIG. 36;
 FIG. 38 is a second side view of the design of FIG. 36;
 FIG. 39 is a top view of the design of FIG. 36;
 FIG. 40 is a bottom view of the design of FIG. 36;
 FIG. 41 is a front view of the design of FIG. 36;
 FIG. 42 is a back view of the design of FIG. 36;
 FIG. 43 is a perspective view of yet another embodiment our new design of a blue sole and midsole assembly for single-sole shoe, where the blue portions indicate the blue color Pantone 3255;
 FIG. 44 is a first side view of the design of FIG. 43;
 FIG. 45 is a second side view of the design of FIG. 43;
 FIG. 46 is a top view of the design of FIG. 43;
 FIG. 47 is a bottom view of the design of FIG. 43;
 FIG. 48 is a front view of the design of FIG. 43;
 FIG. 49 is a back view of the design of FIG. 43;
 FIG. 50 is a perspective view of yet another embodiment our new design of a blue sole and midsole assembly for single-sole shoe, where the blue portions indicate the blue color Pantone 5405;
 FIG. 51 is a first side view of the design of FIG. 50;
 FIG. 52 is a second side view of the design of FIG. 50;
 FIG. 53 is a top view of the design of FIG. 50;
 FIG. 54 is a bottom view of the design of FIG. 50;
 FIG. 55 is a front view of the design of FIG. 50;
 FIG. 56 is a back view of the design of FIG. 50;
 FIG. 57 is a perspective view of yet another embodiment our new design of a blue sole and midsole assembly for single-sole shoe, where the blue portions indicate the blue color RAL 5003;
 FIG. 58 is a first side view of the design of FIG. 57;
 FIG. 59 is a second side view of the design of FIG. 57;
 FIG. 60 is a top view of the design of FIG. 57;
 FIG. 61 is a bottom view of the design of FIG. 57;
 FIG. 62 is a front view of the design of FIG. 57;
 FIG. 63 is a back view of the design of FIG. 57;
 FIG. 64 is a perspective view of yet another embodiment our new design of a blue sole and midsole assembly for single-sole shoe, where the blue portions indicate the blue color RAL 5015;
 FIG. 65 is a first side view of the design of FIG. 64;
 FIG. 66 is a second side view of the design of FIG. 64;
 FIG. 67 is a top view of the design of FIG. 64;
 FIG. 68 is a bottom view of the design of FIG. 64;
 FIG. 69 is a front view of the design of FIG. 64; and,
 FIG. 70 is a back view of the design of FIG. 64.
 The broken lines showing elements in the above described Figures are for illustrative purposes only and form no part of the claimed design.

**1 Claim, 60 Drawing Sheets
 (54 of 60 Drawing Sheet(s) Filed in Color)**

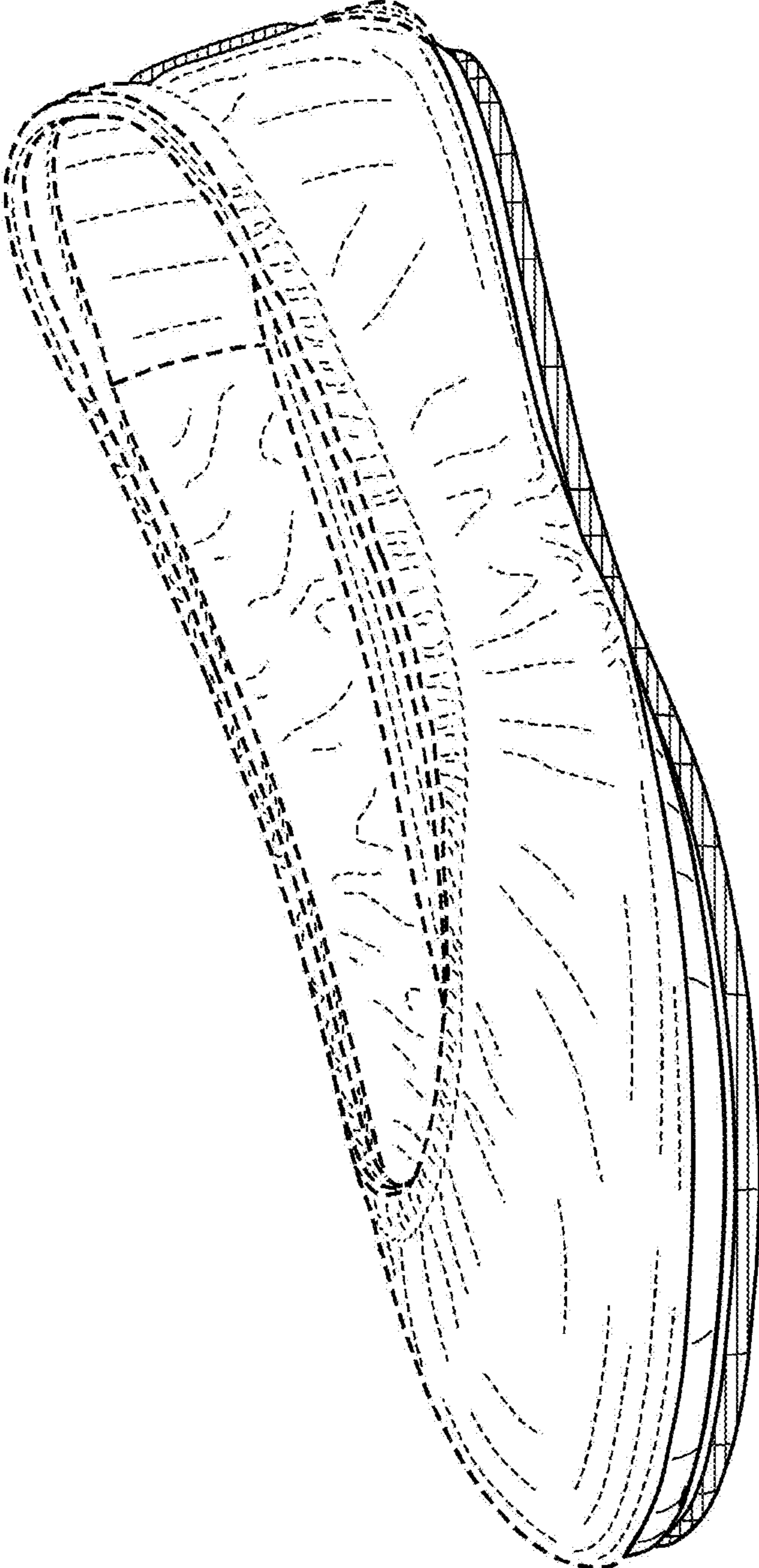

FIG. 1

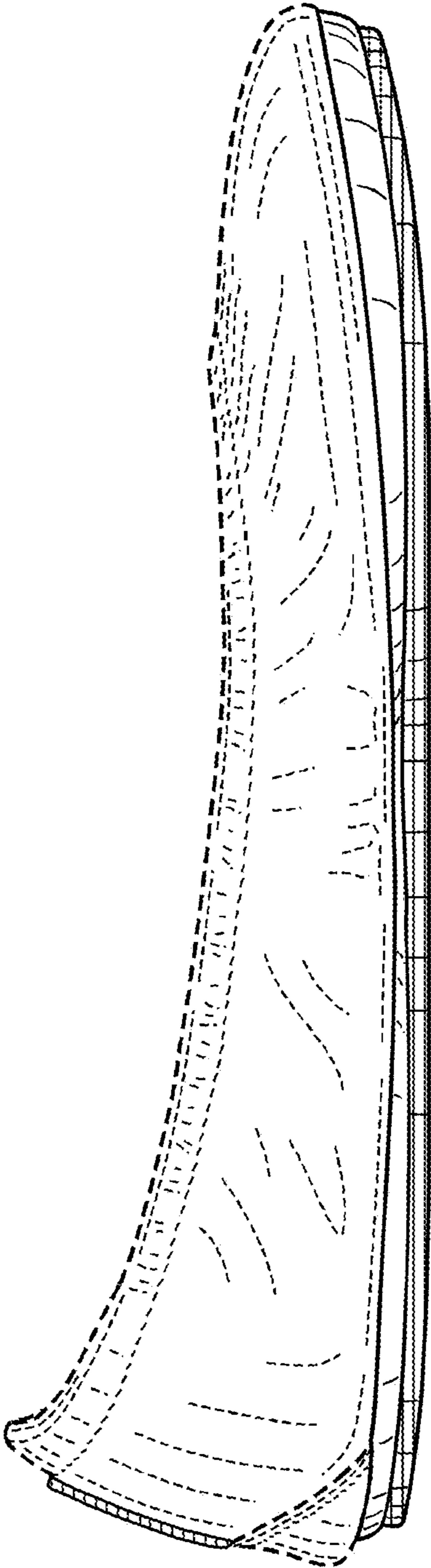

FIG. 2

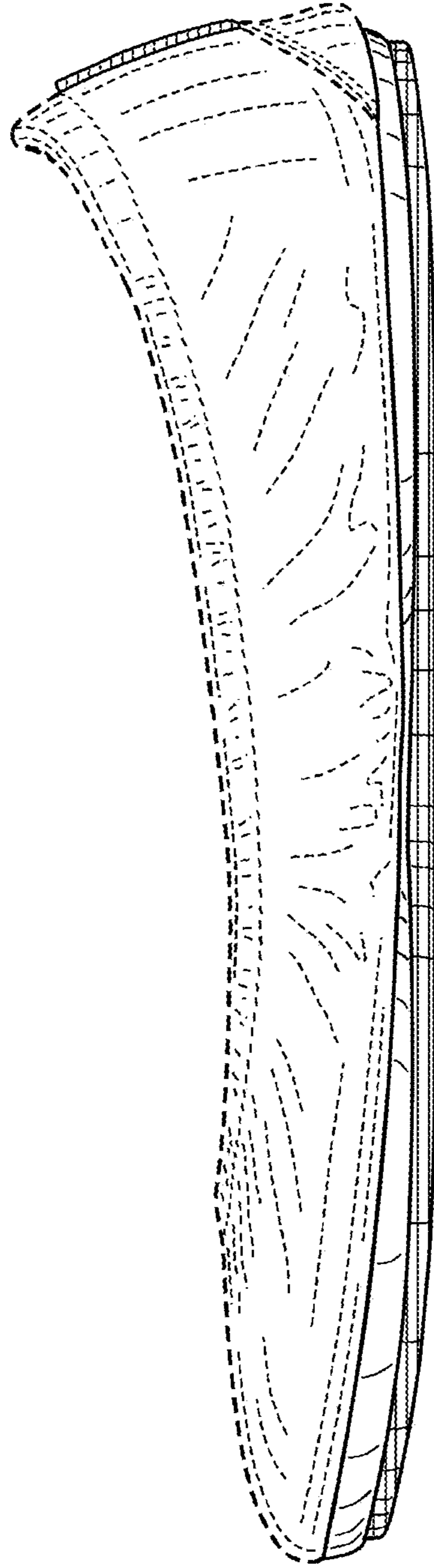

FIG. 3

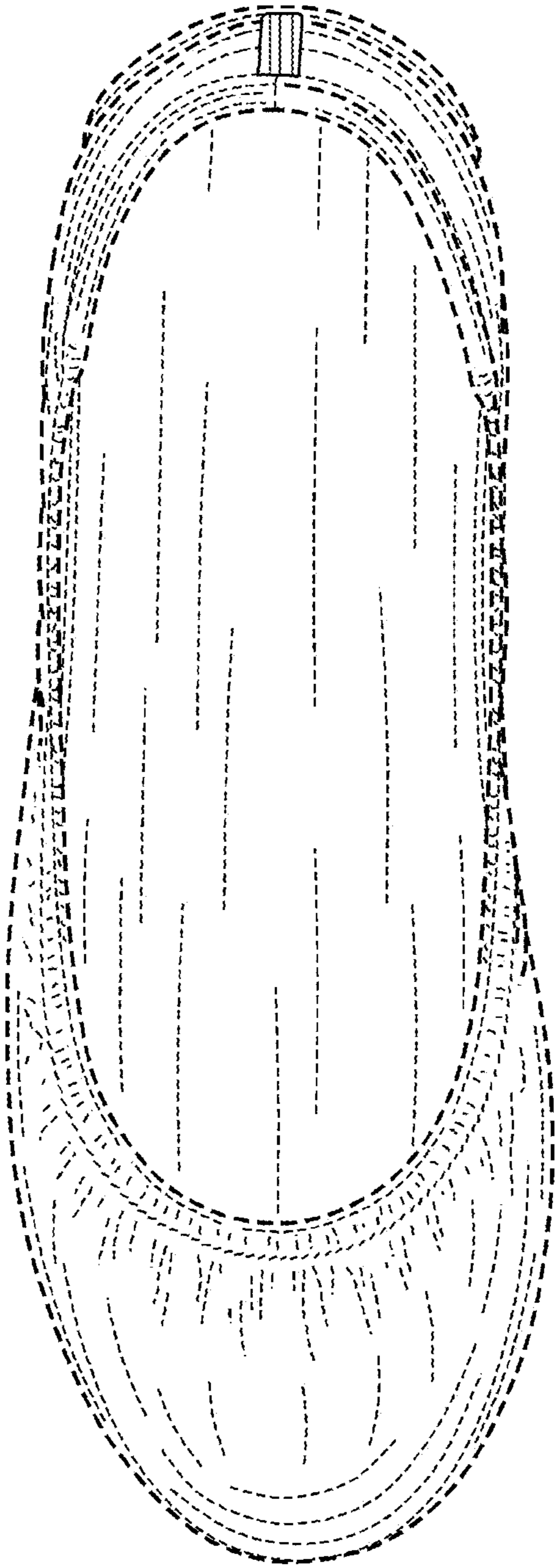

FIG. 4

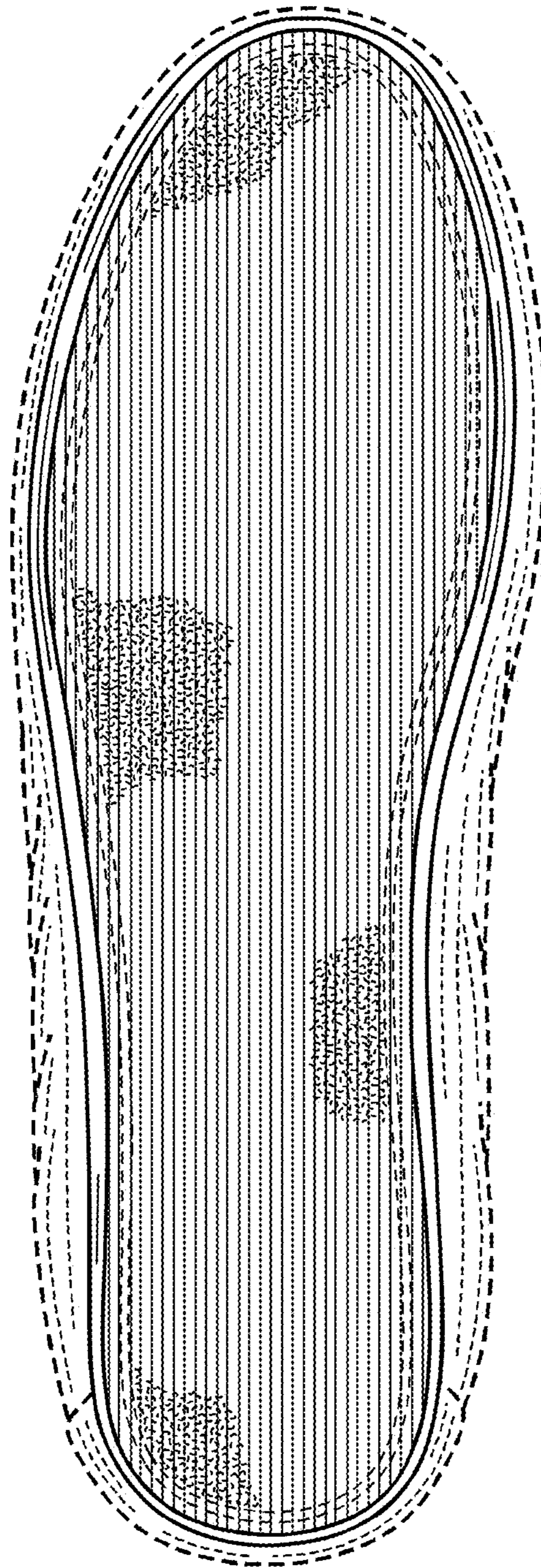

FIG. 5

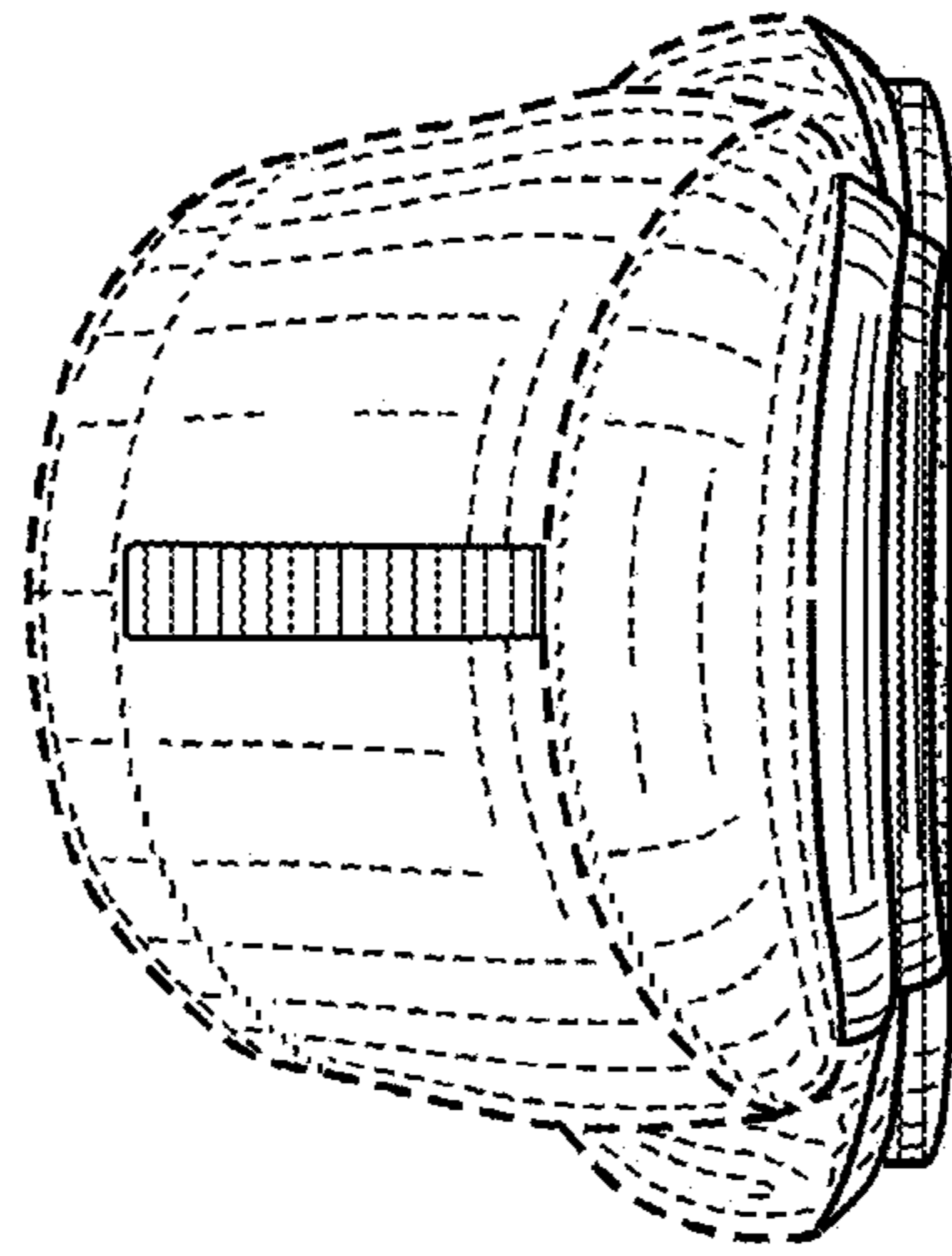

FIG. 6

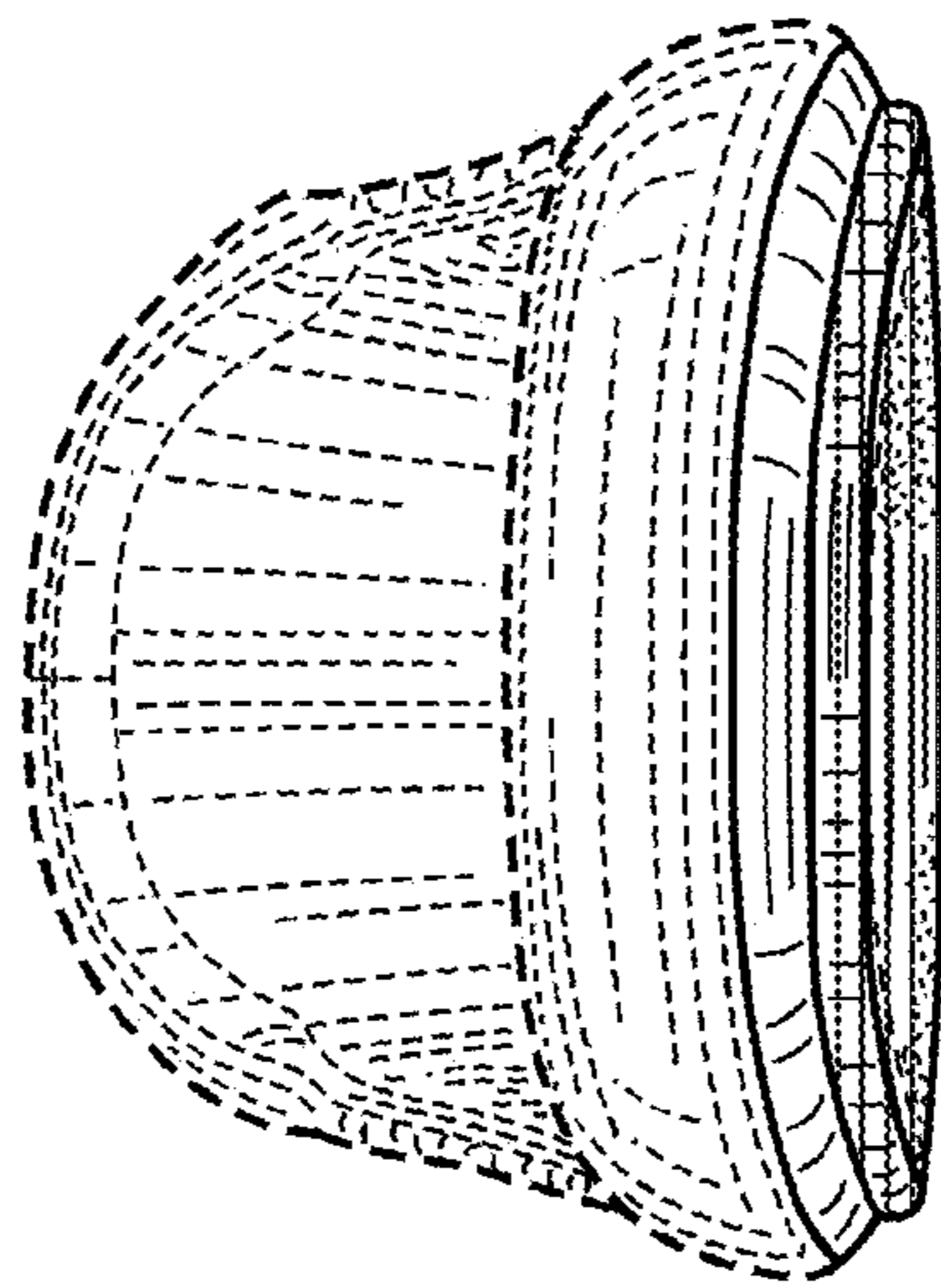

FIG. 7

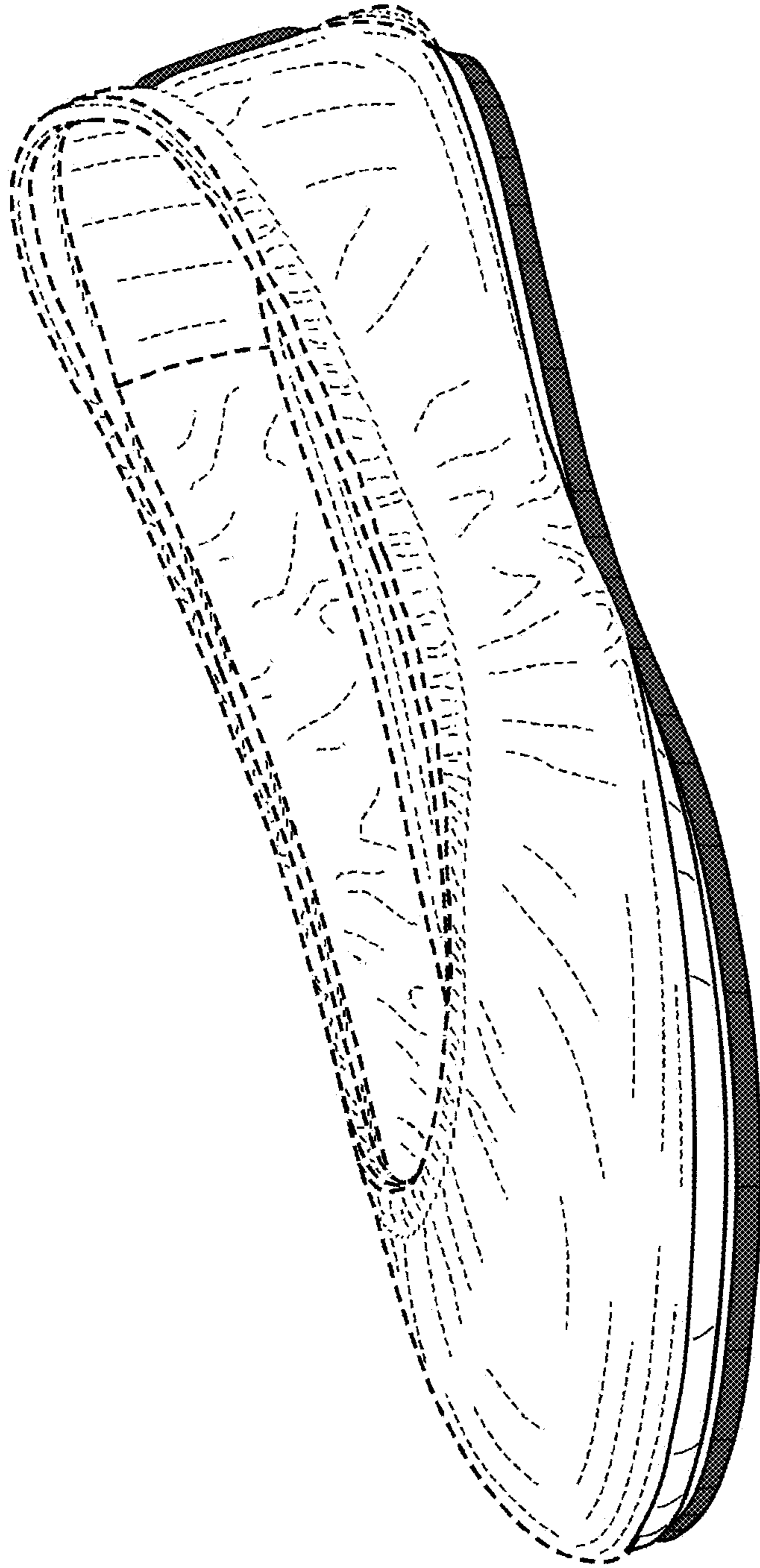

FIG. 8

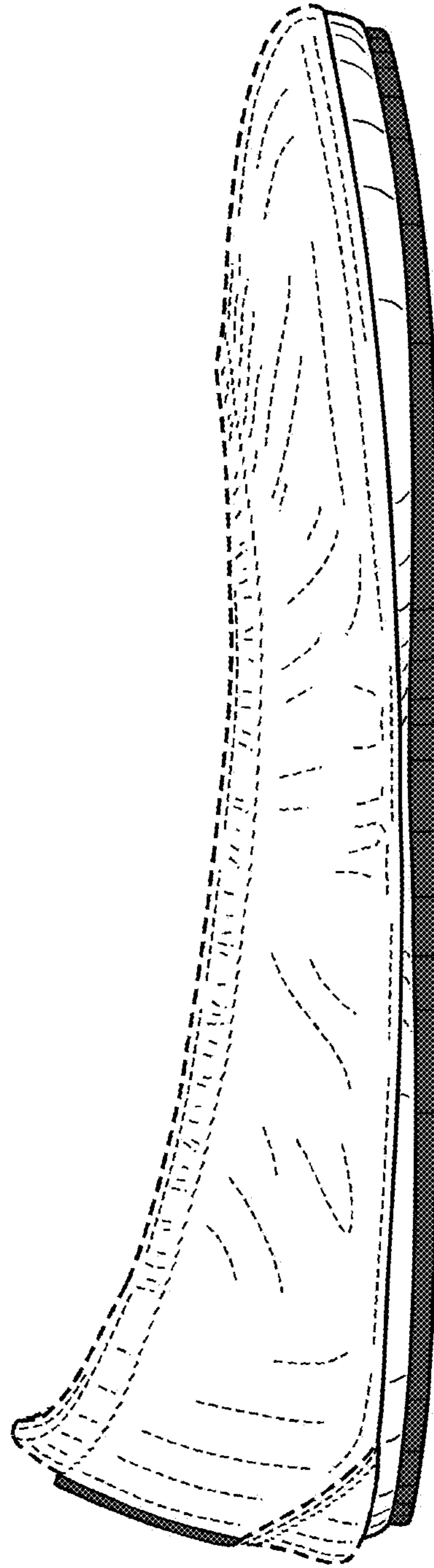

FIG. 9

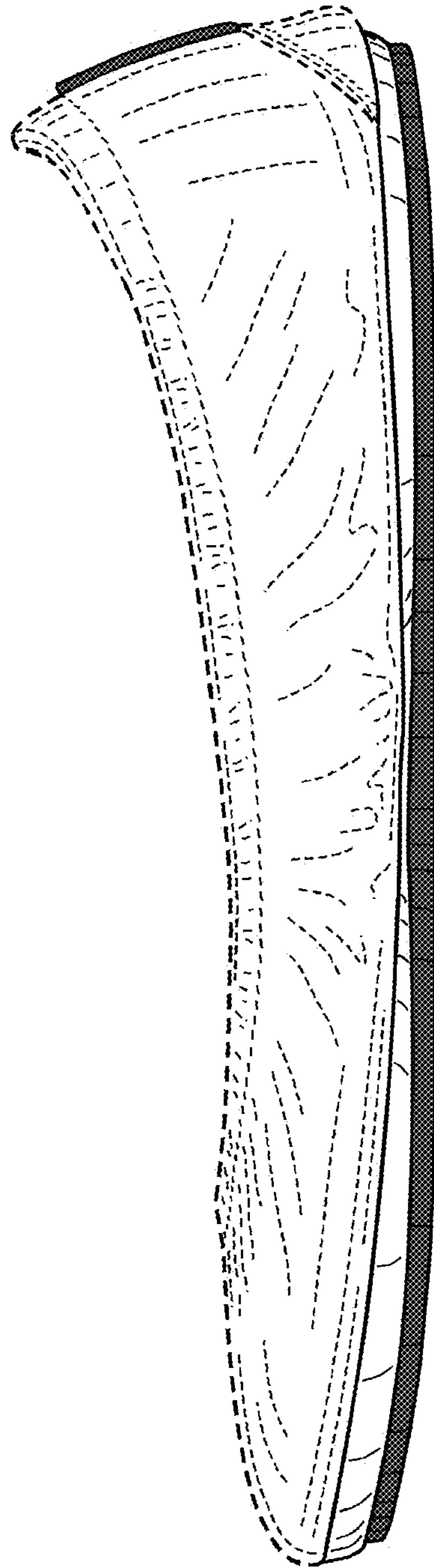

FIG. 10

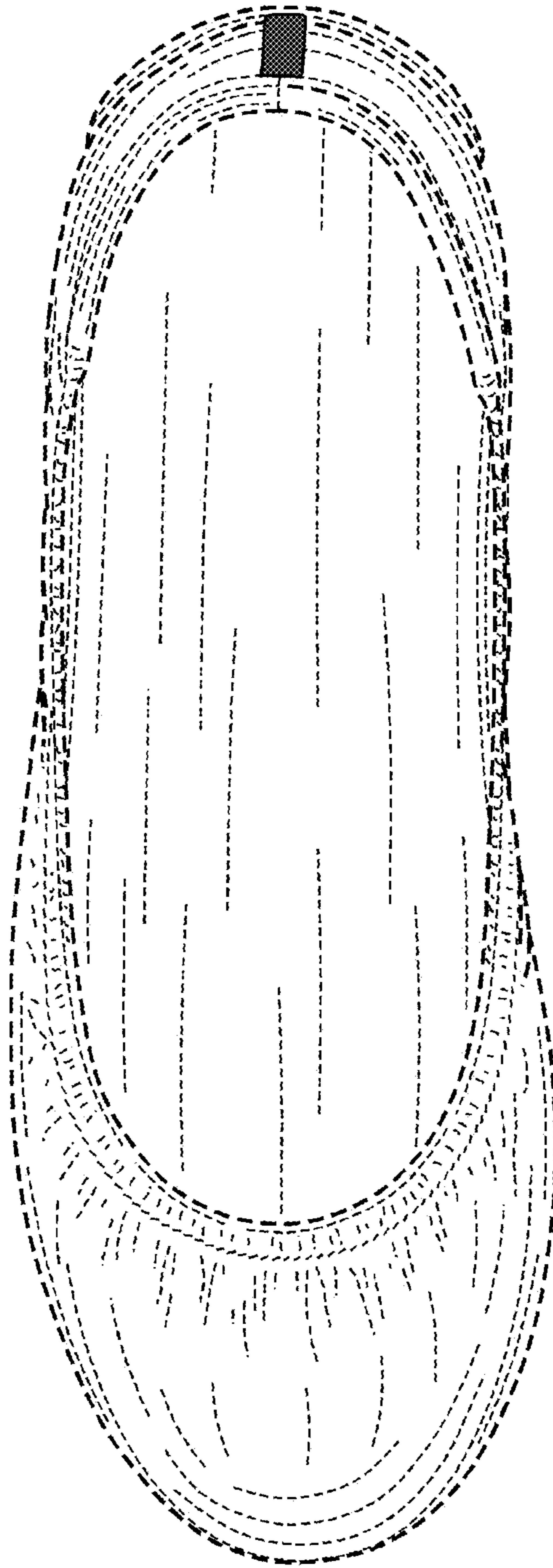

FIG. 11

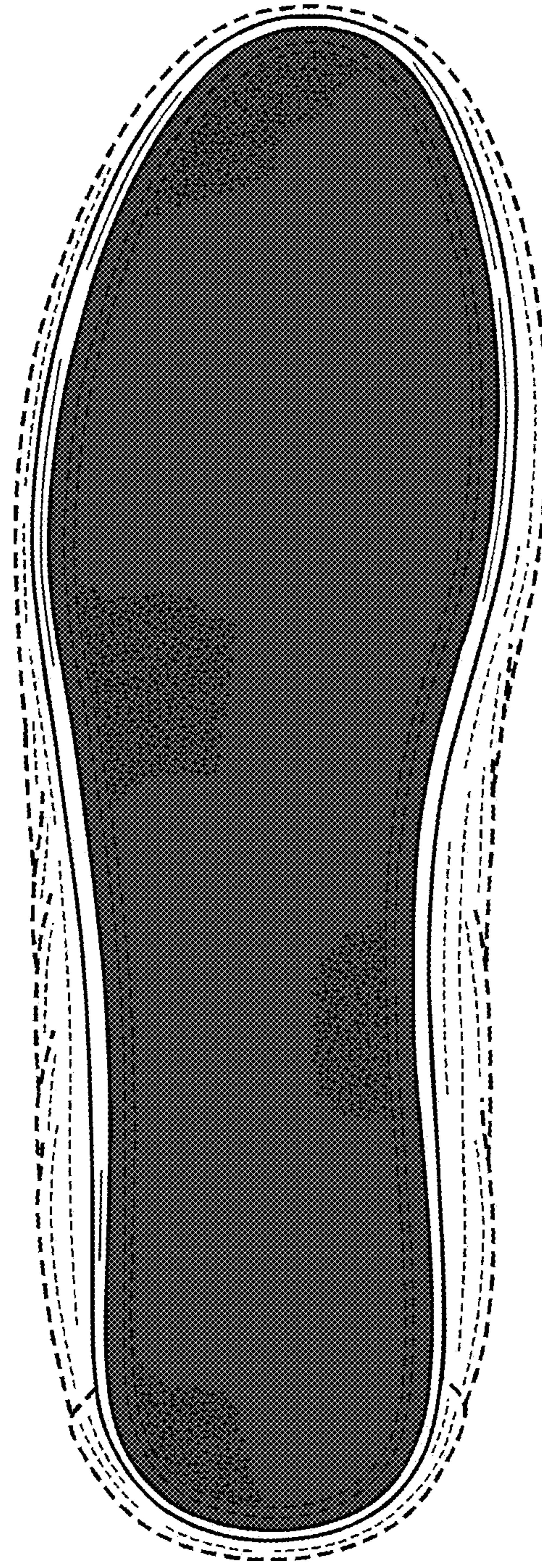

FIG. 12

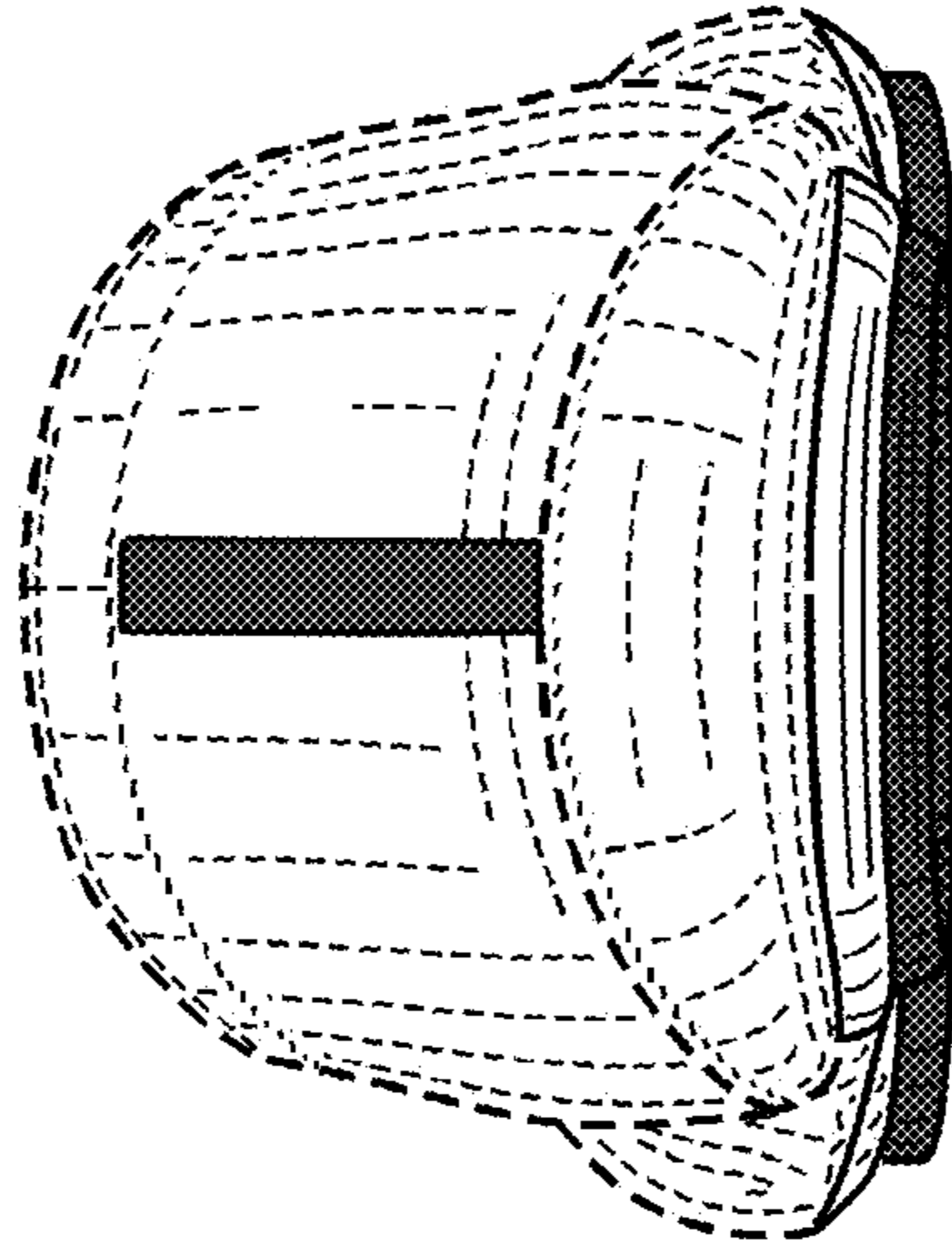

FIG. 14

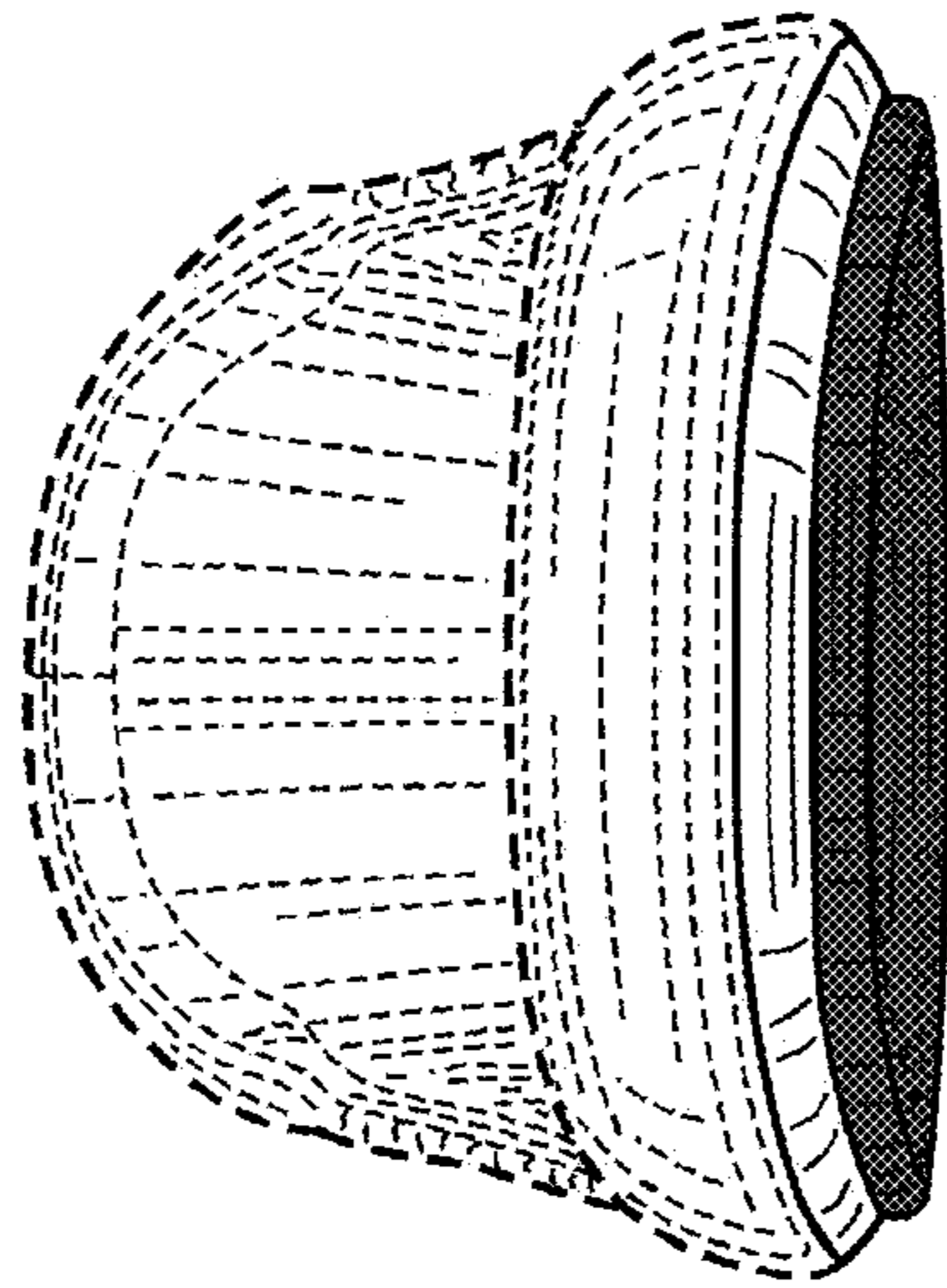

FIG. 13

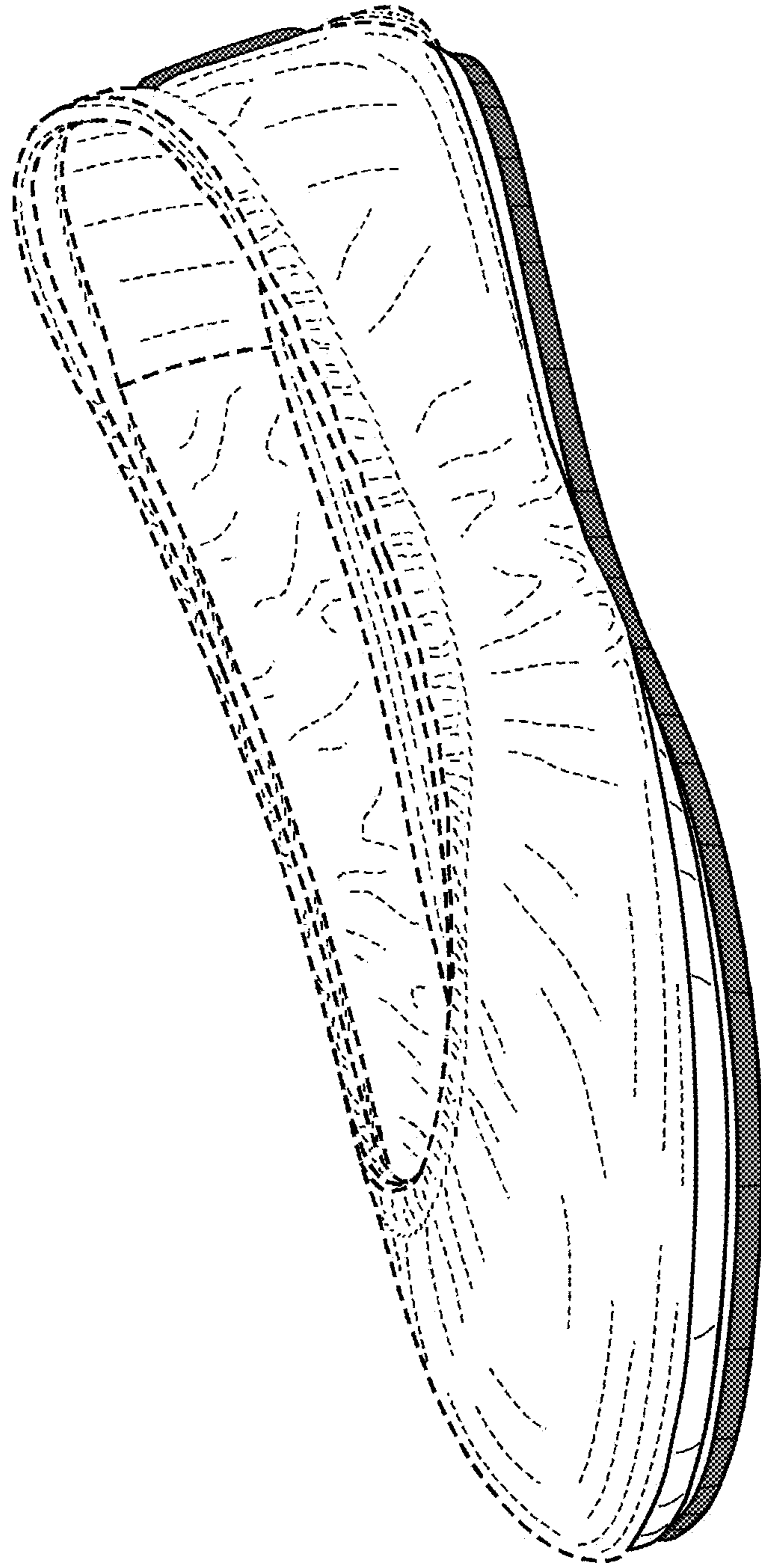

FIG. 15

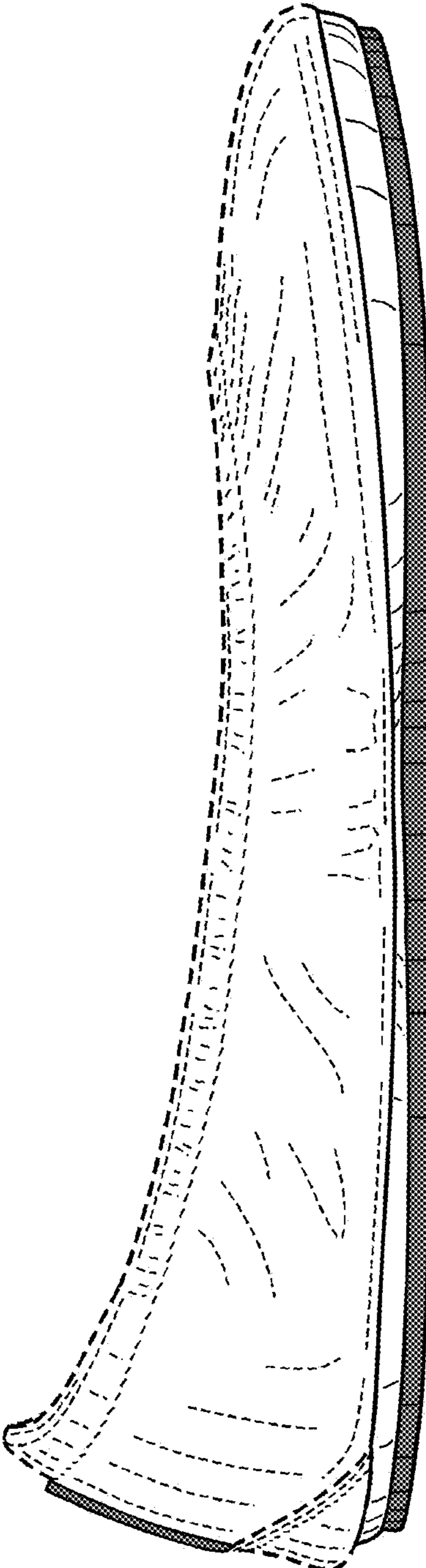

FIG. 16

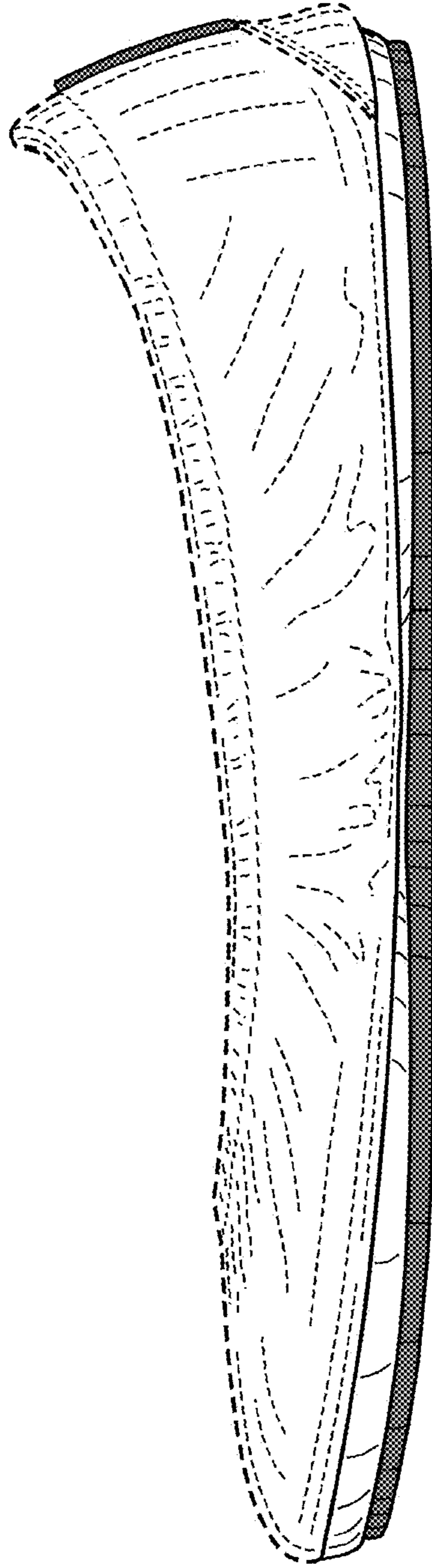

FIG. 17

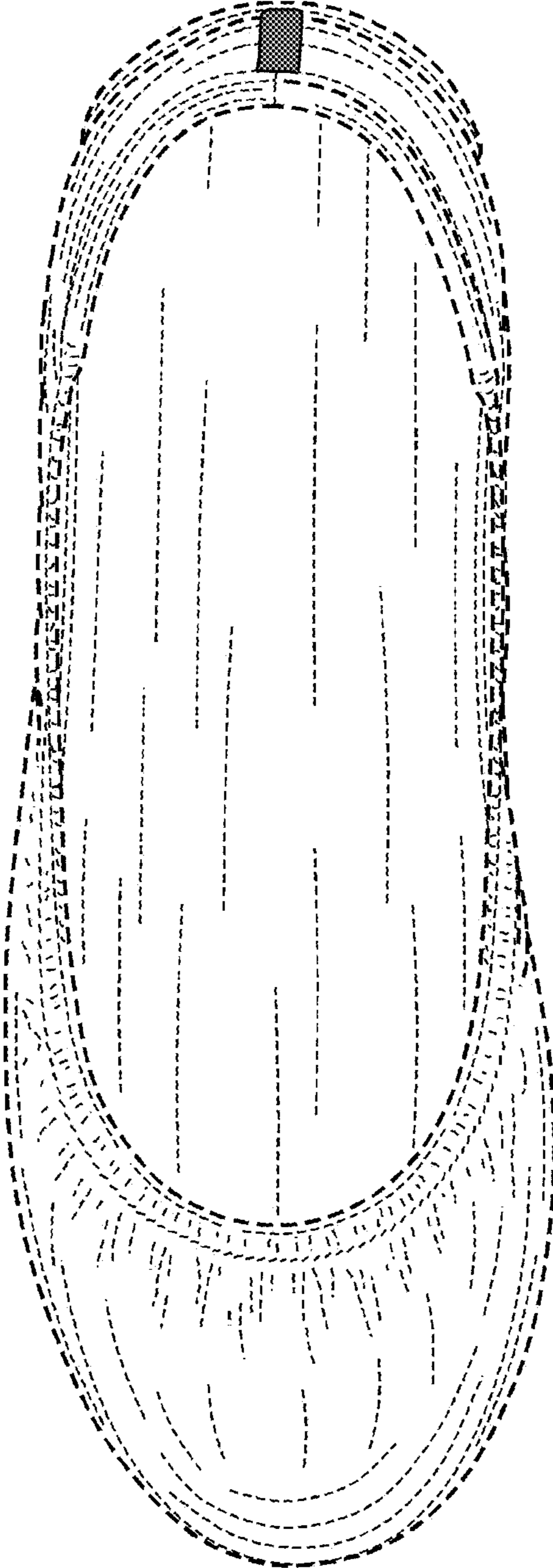

FIG. 18

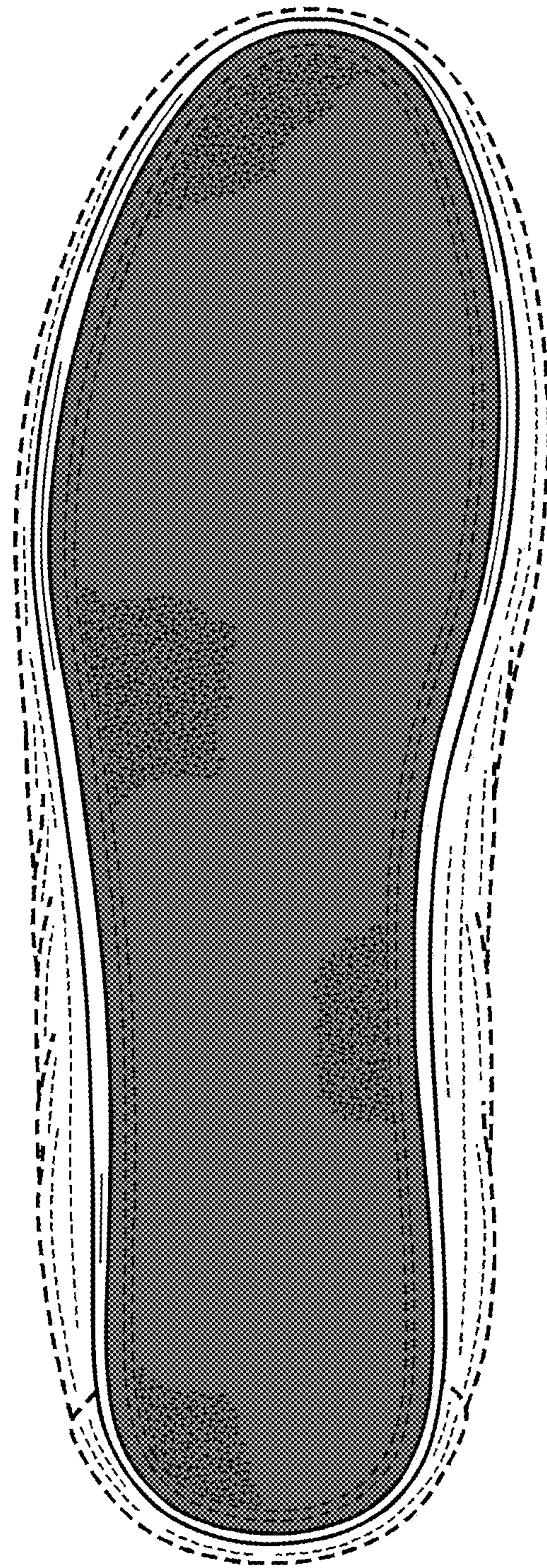

FIG. 19

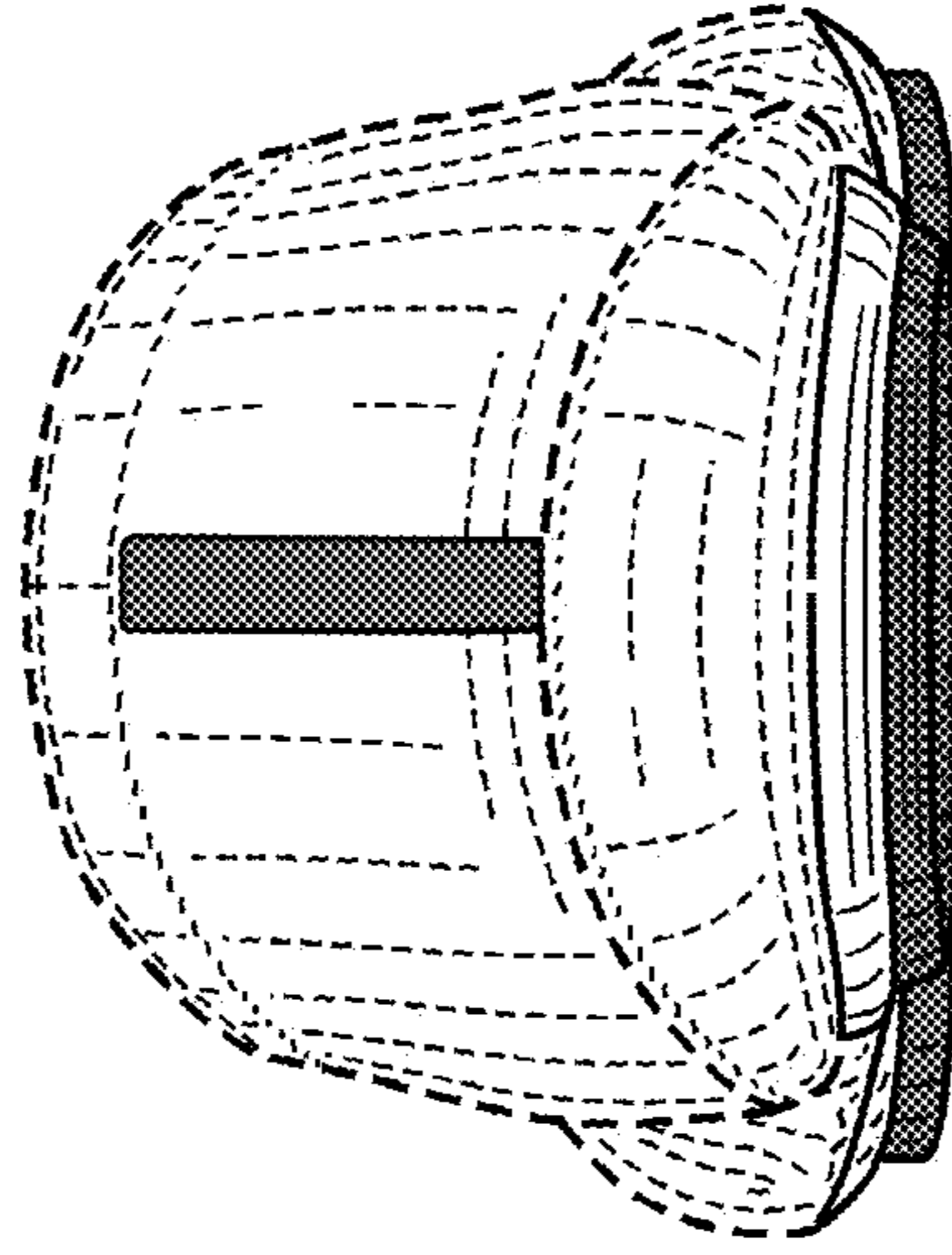

FIG. 21

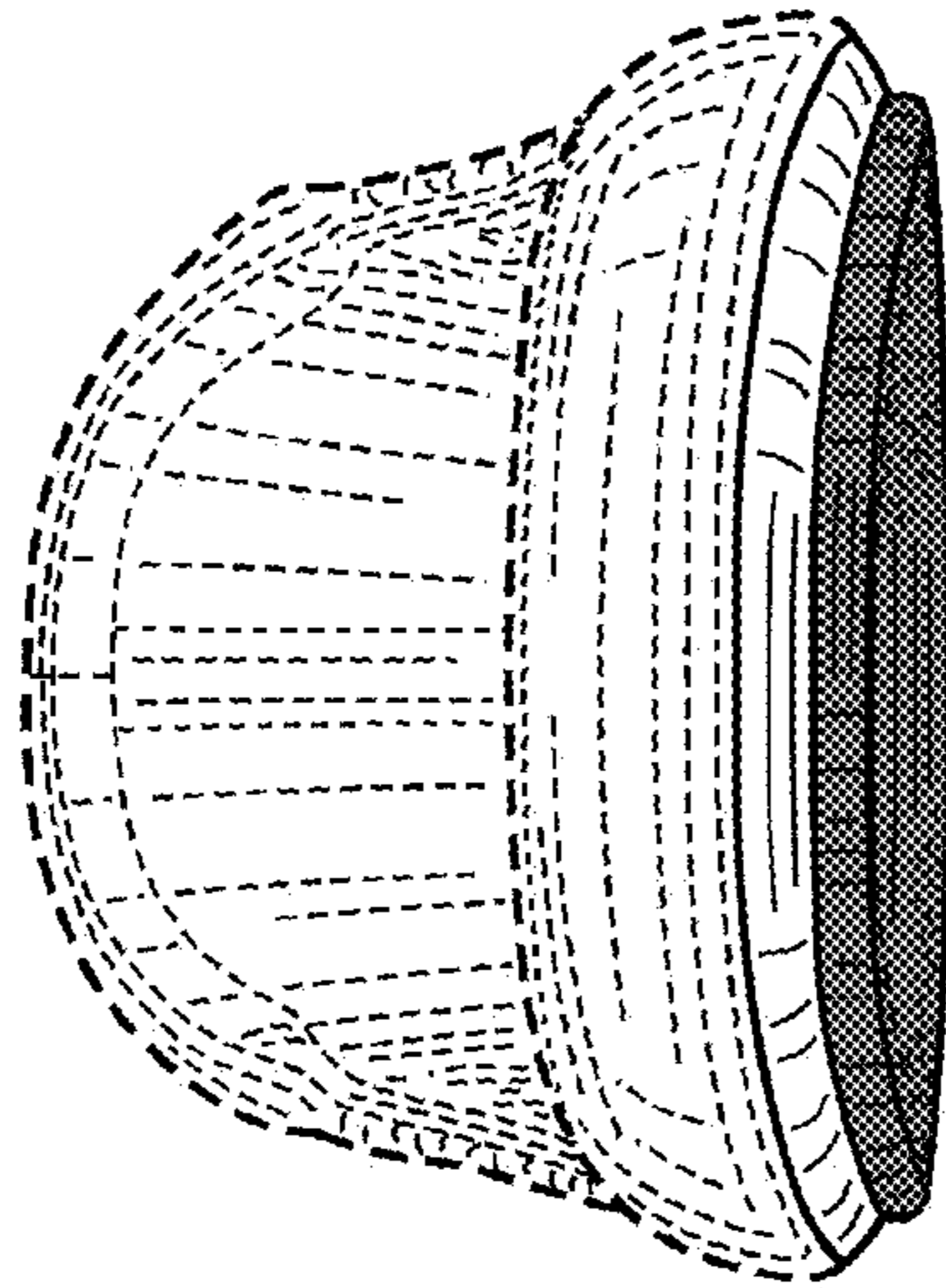

FIG. 20

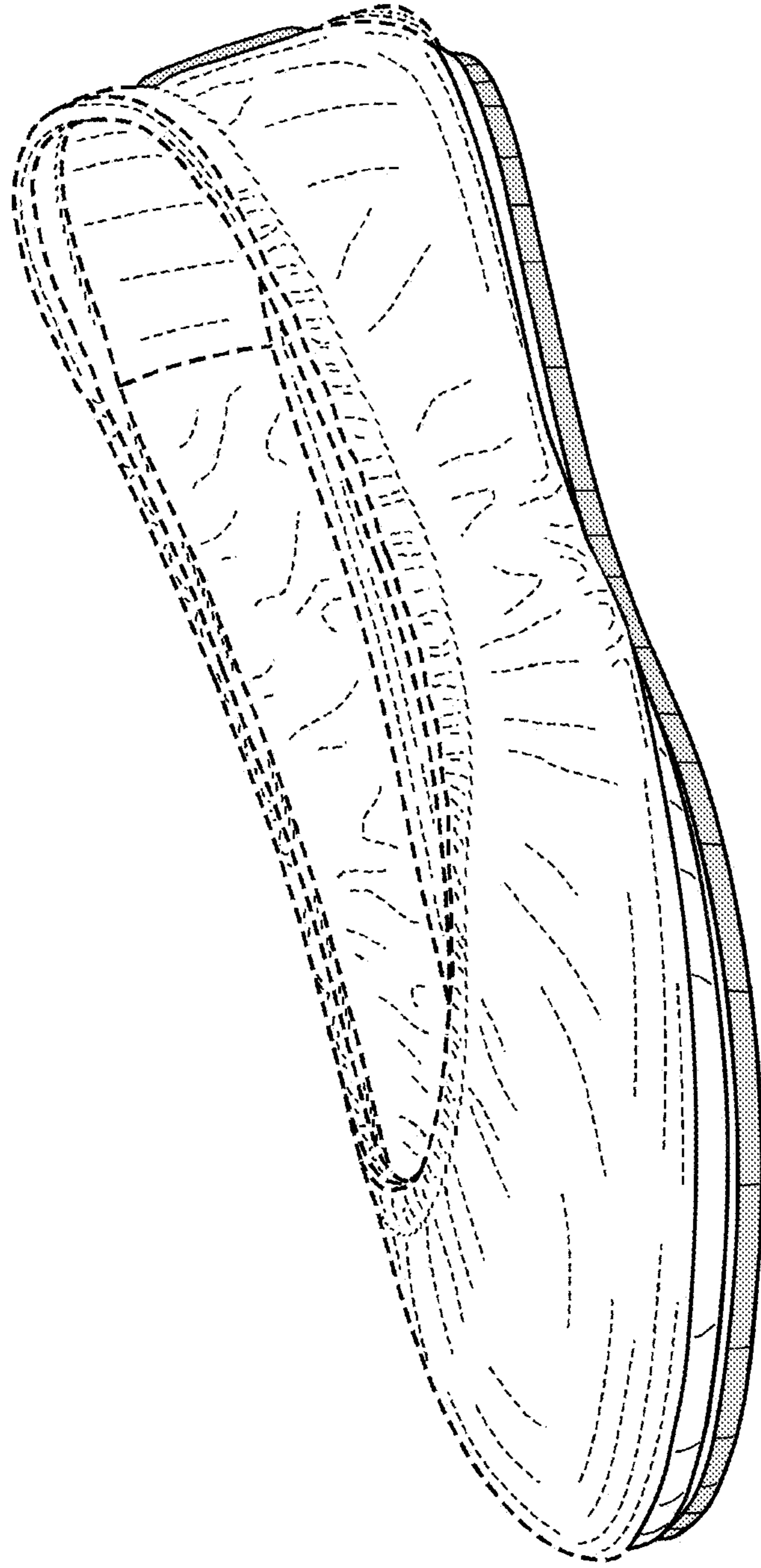

FIG. 22

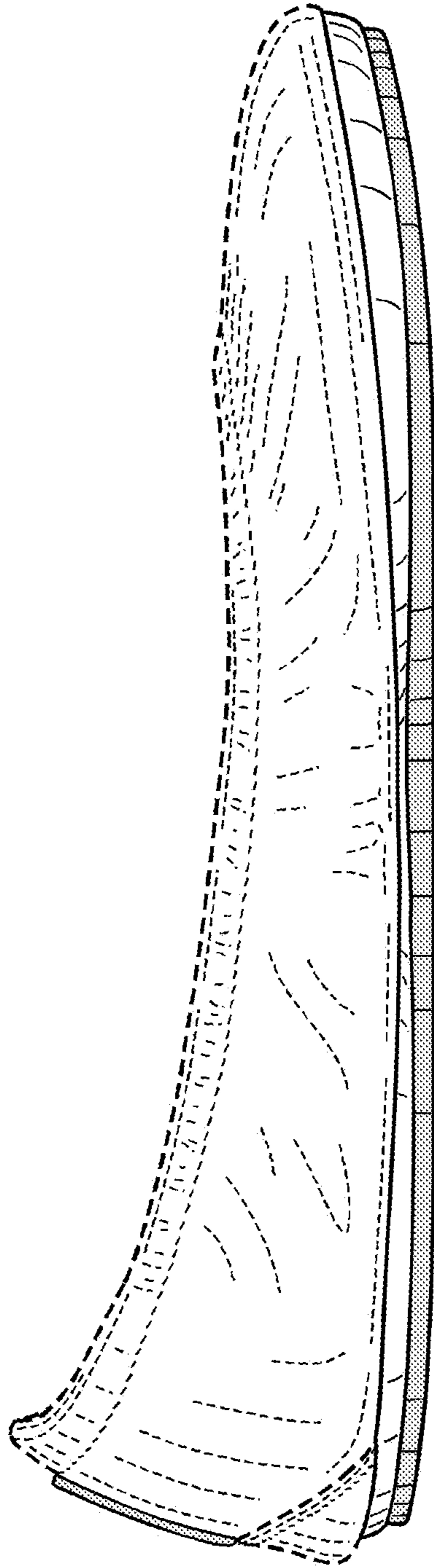

FIG. 23

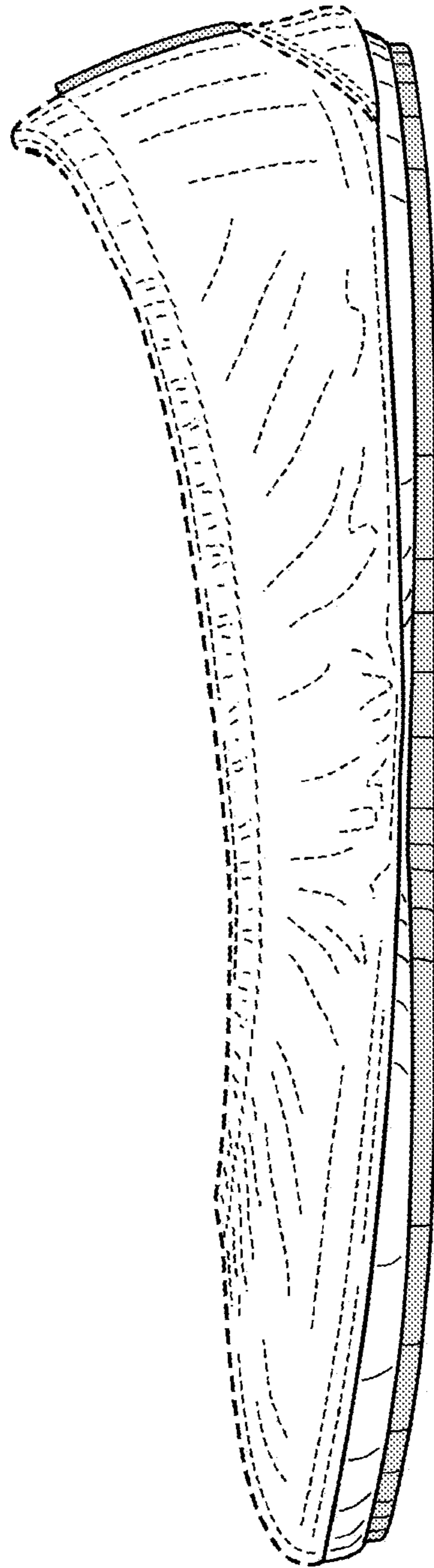

FIG. 24

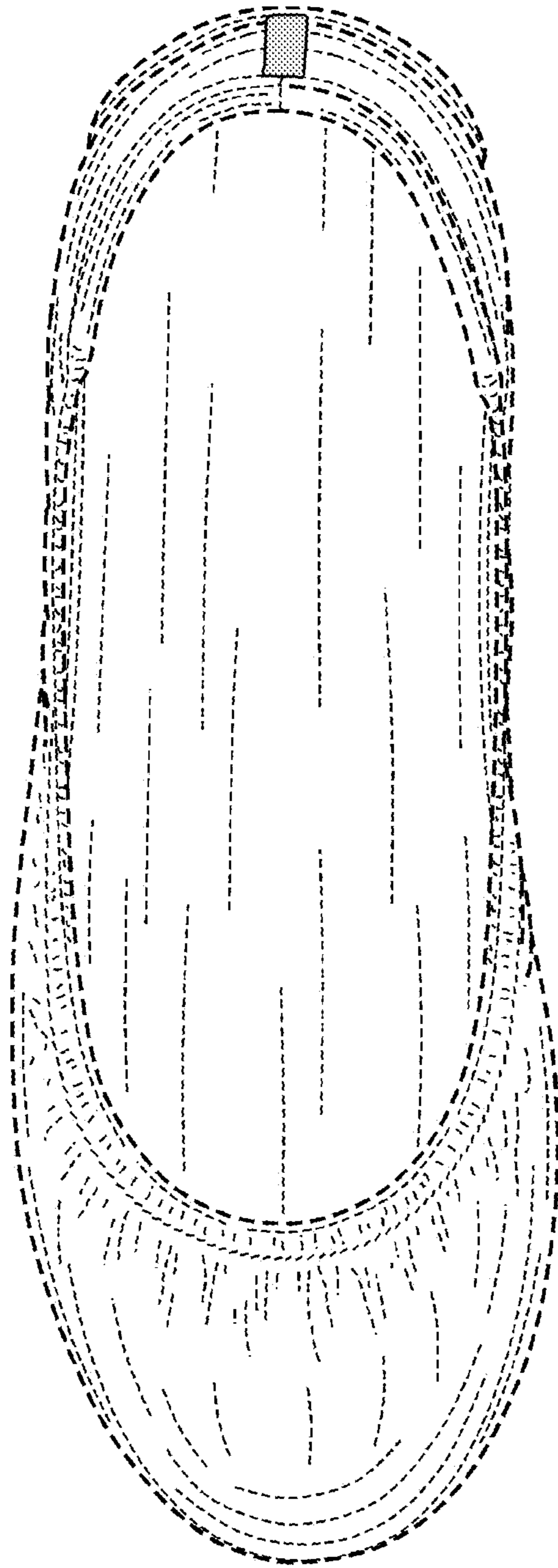

FIG. 25

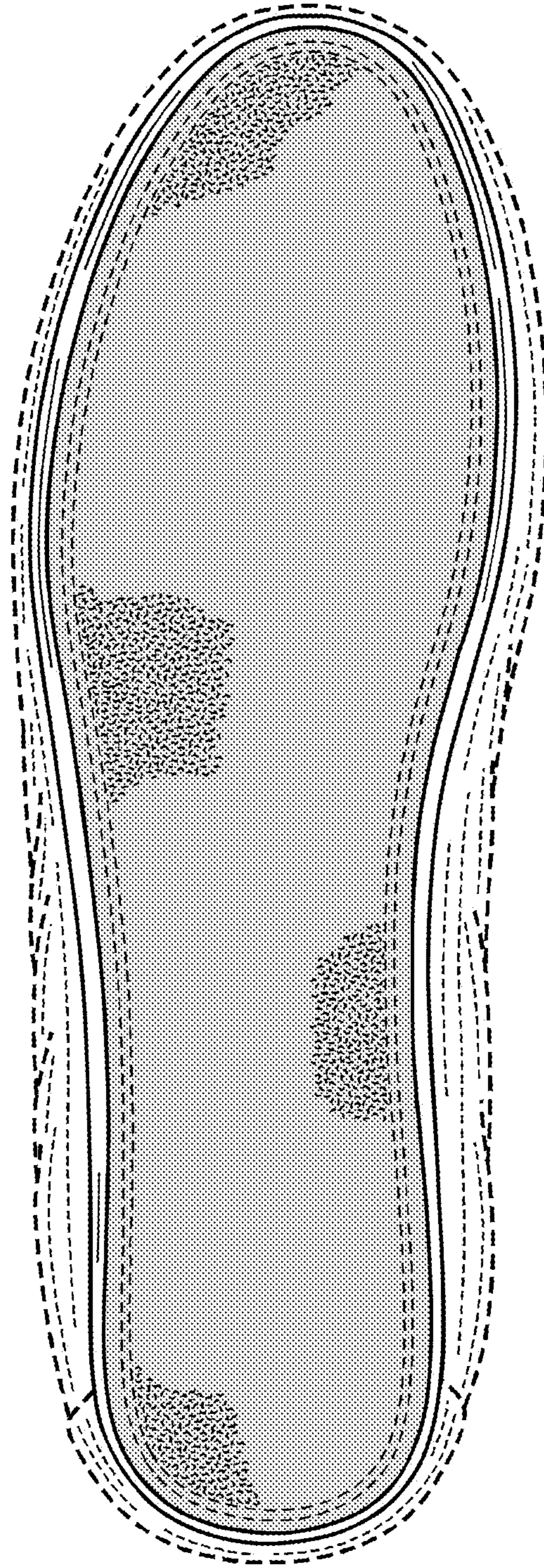

FIG. 26

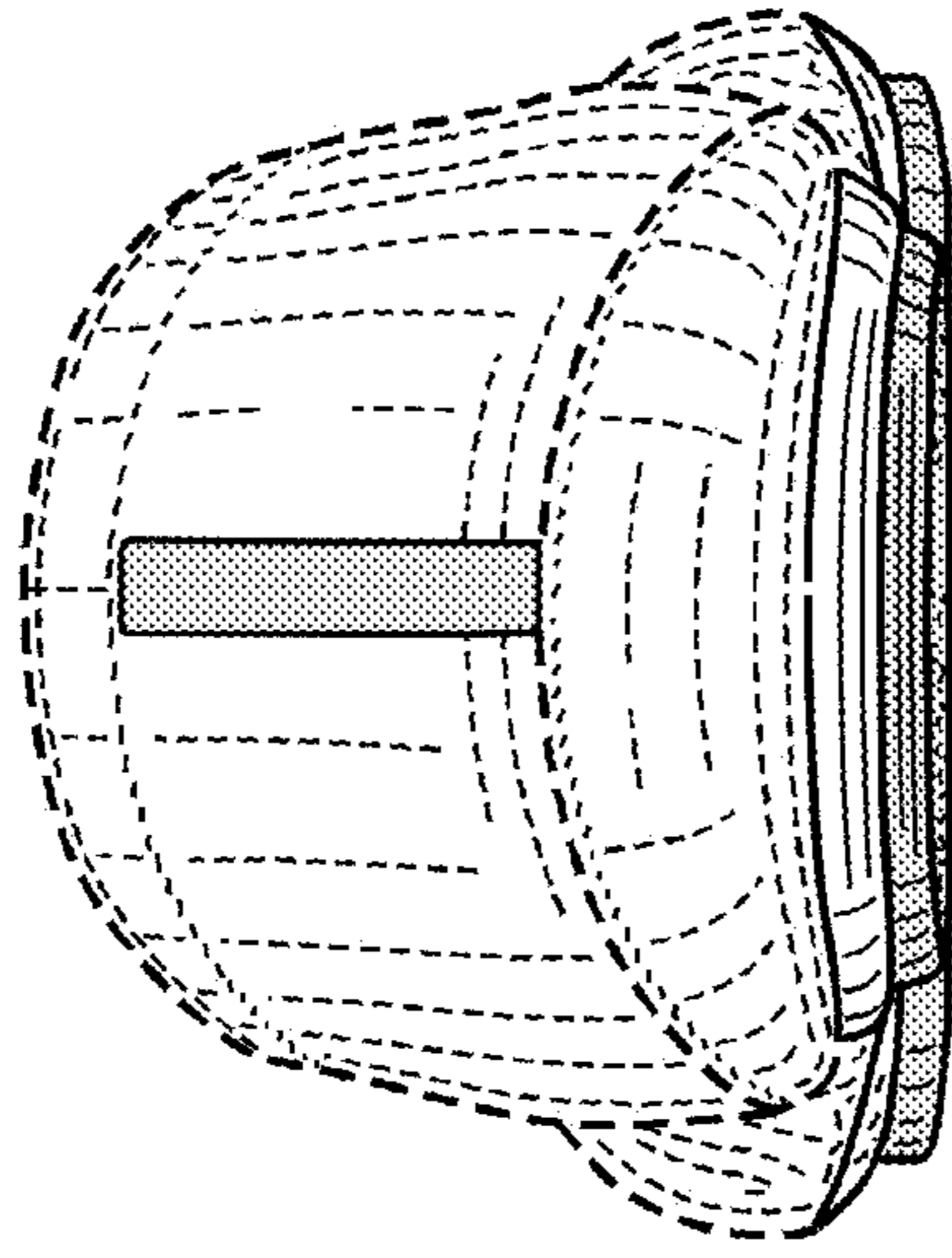

FIG. 27

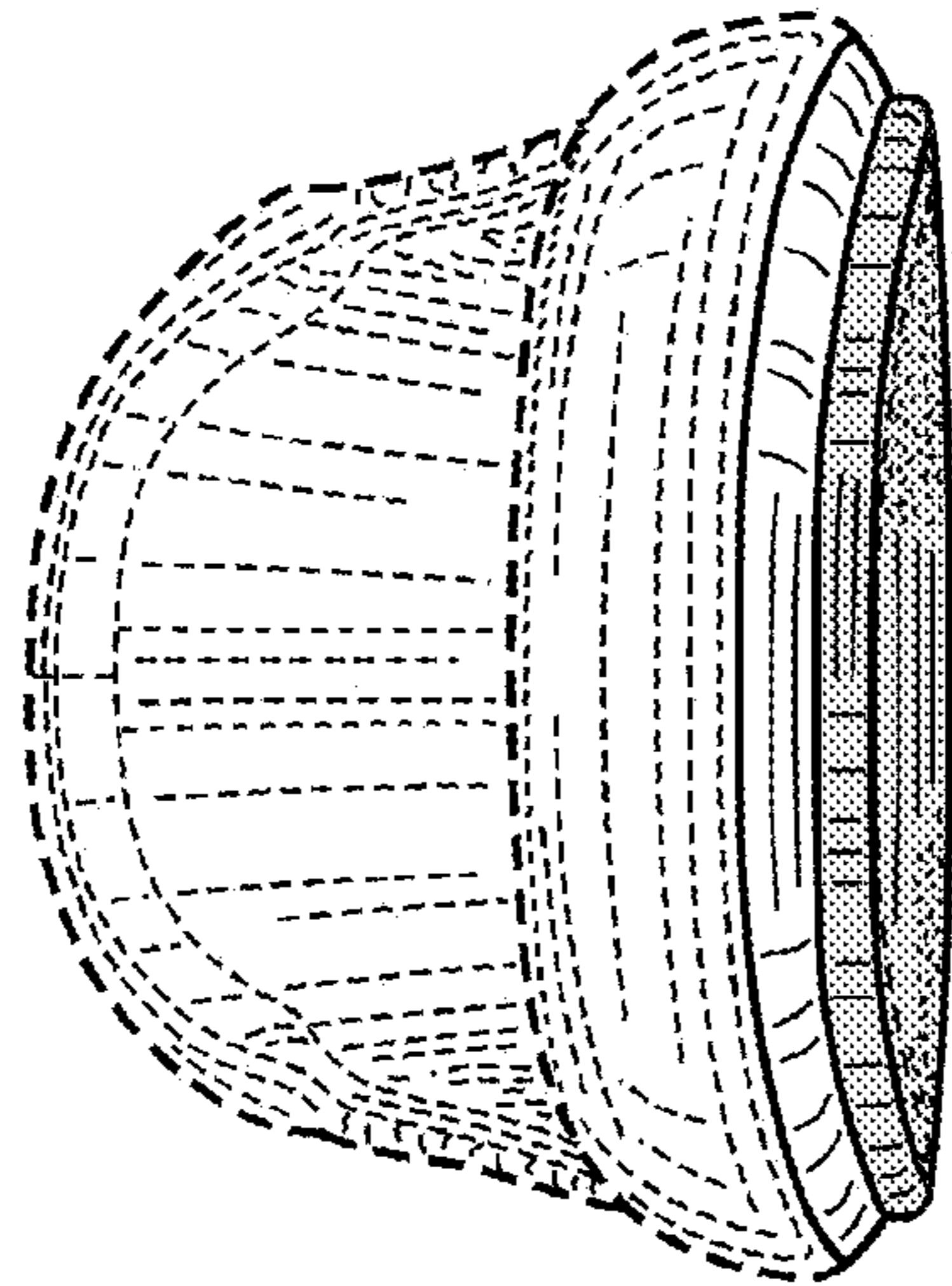

FIG. 28

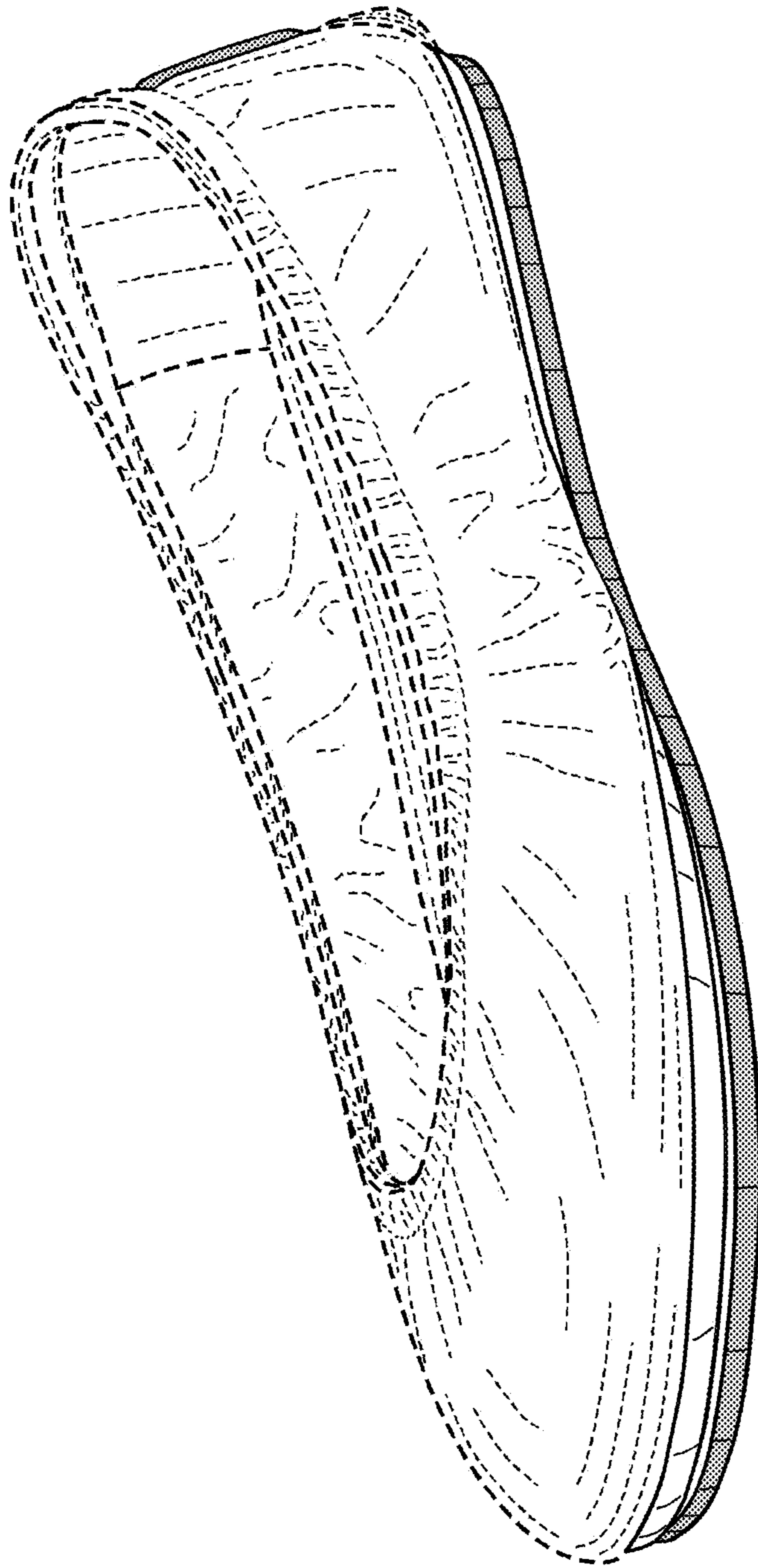

FIG. 29

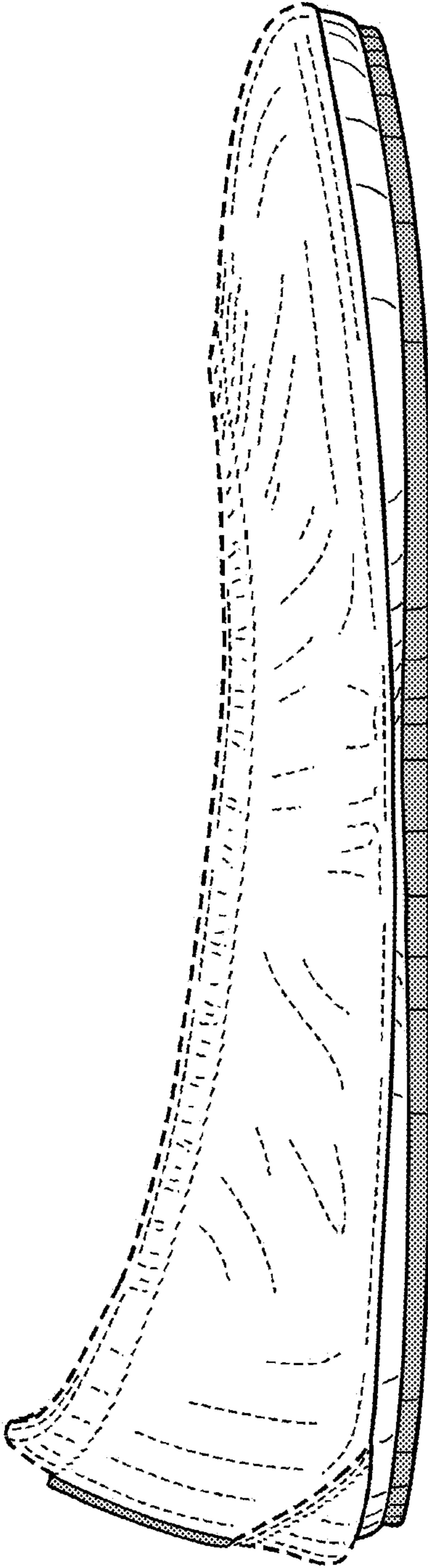

FIG. 30

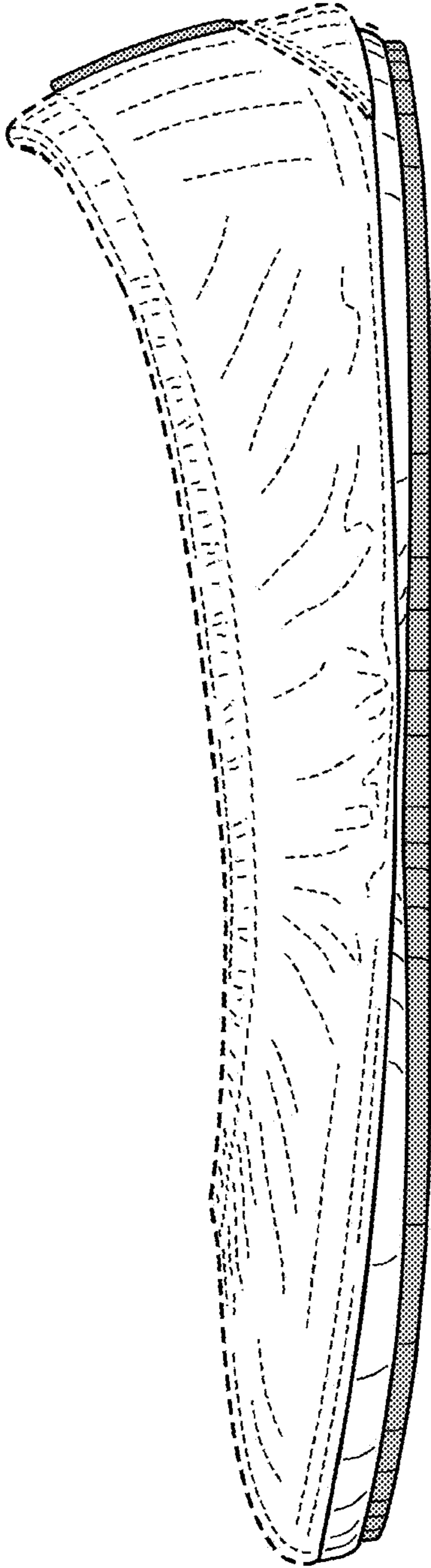

FIG. 31

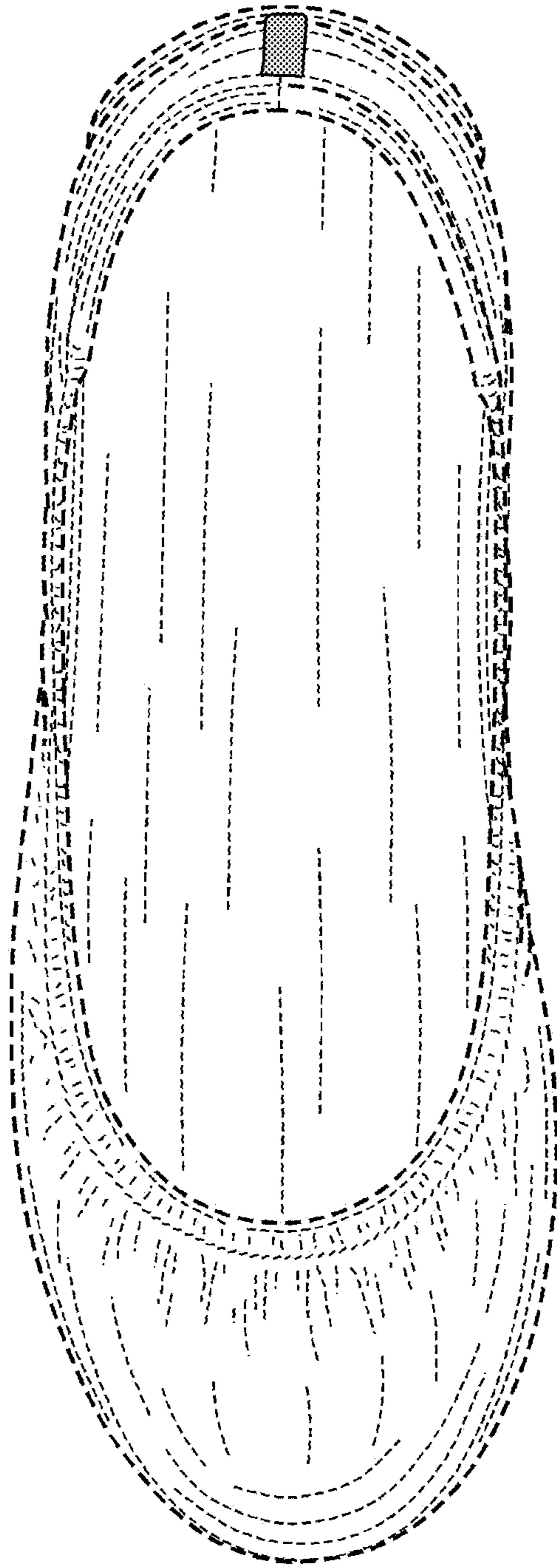

FIG. 32

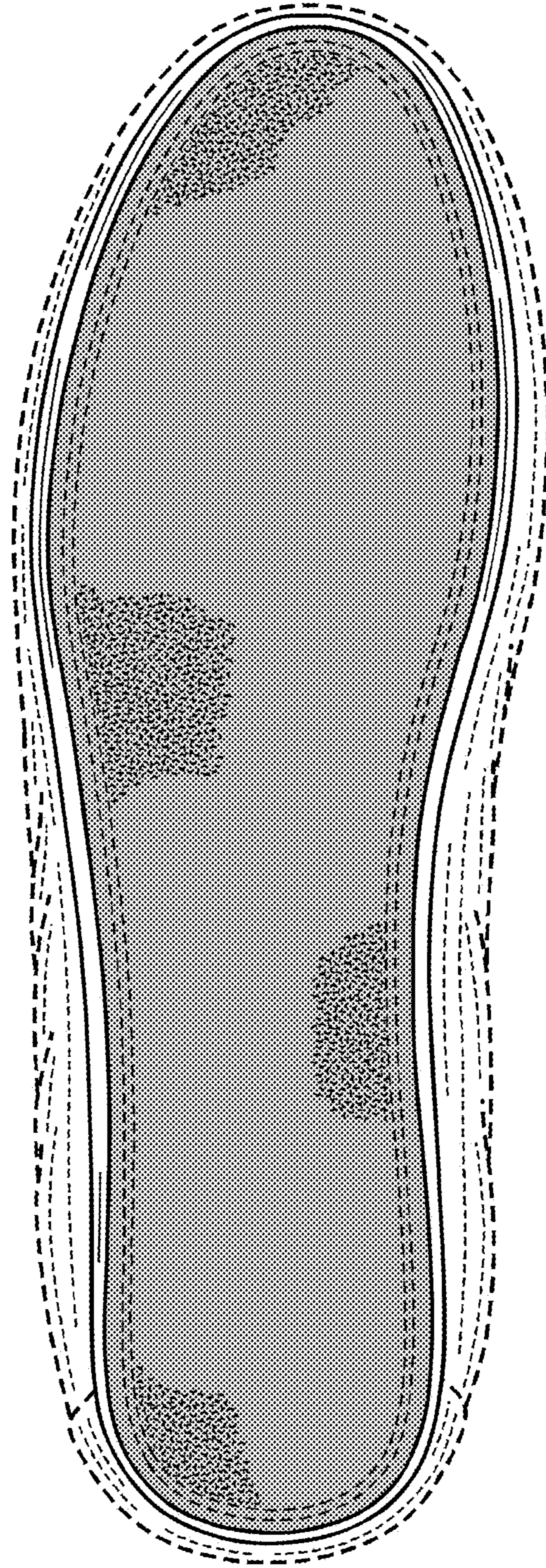

FIG. 33

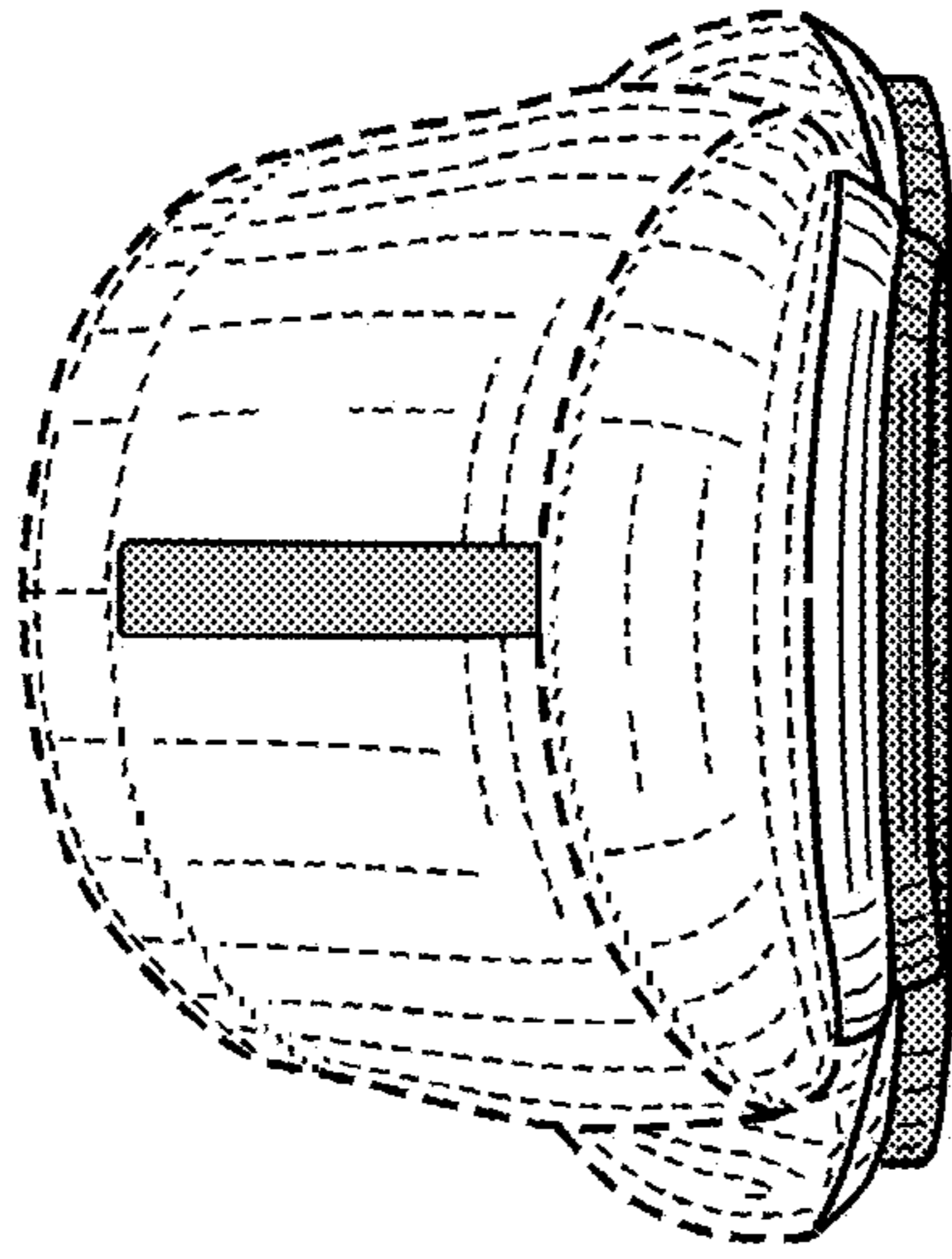

FIG. 35

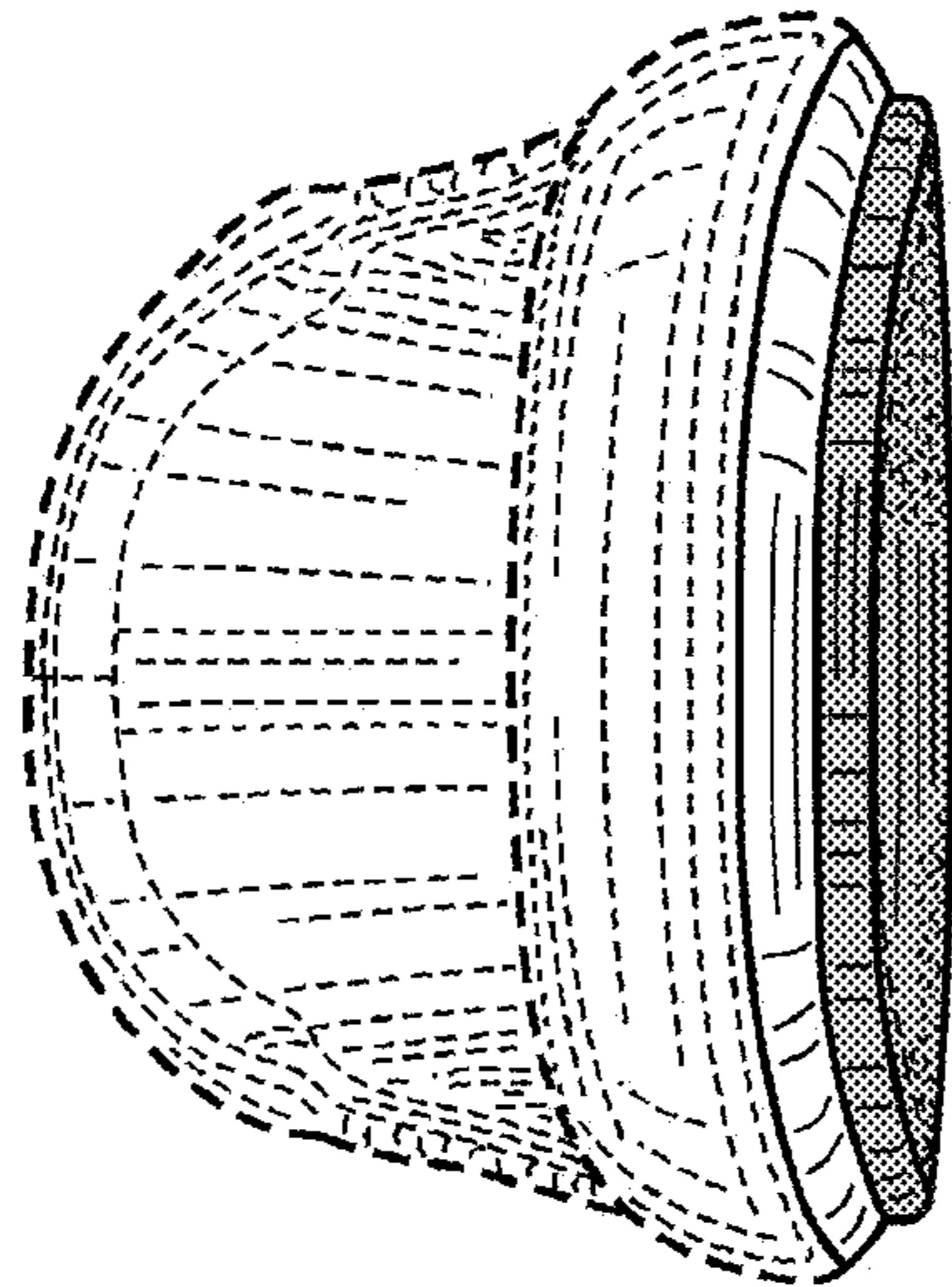

FIG. 34

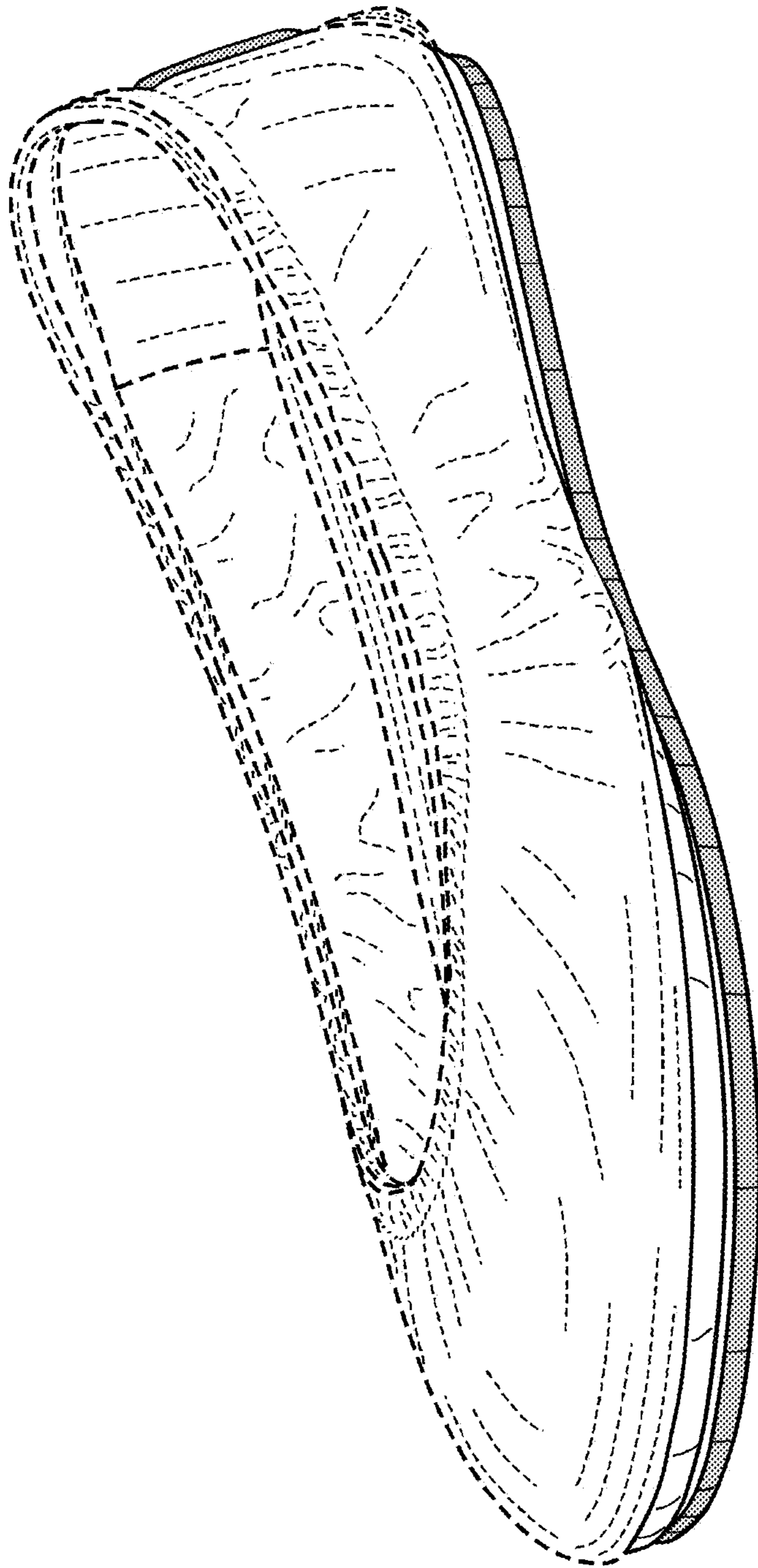

FIG. 36

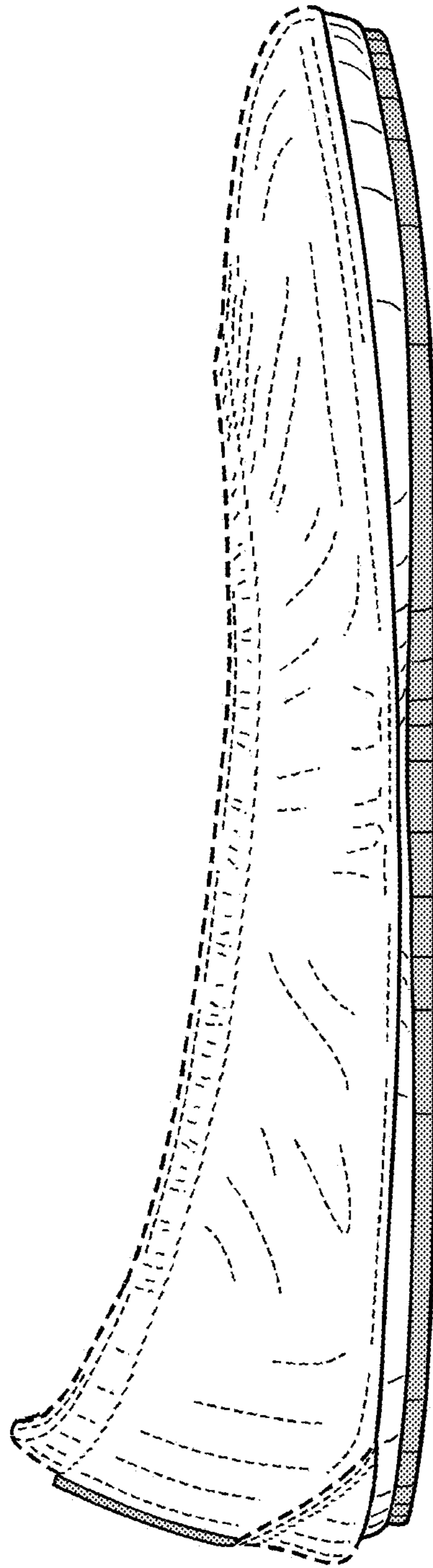

FIG. 37

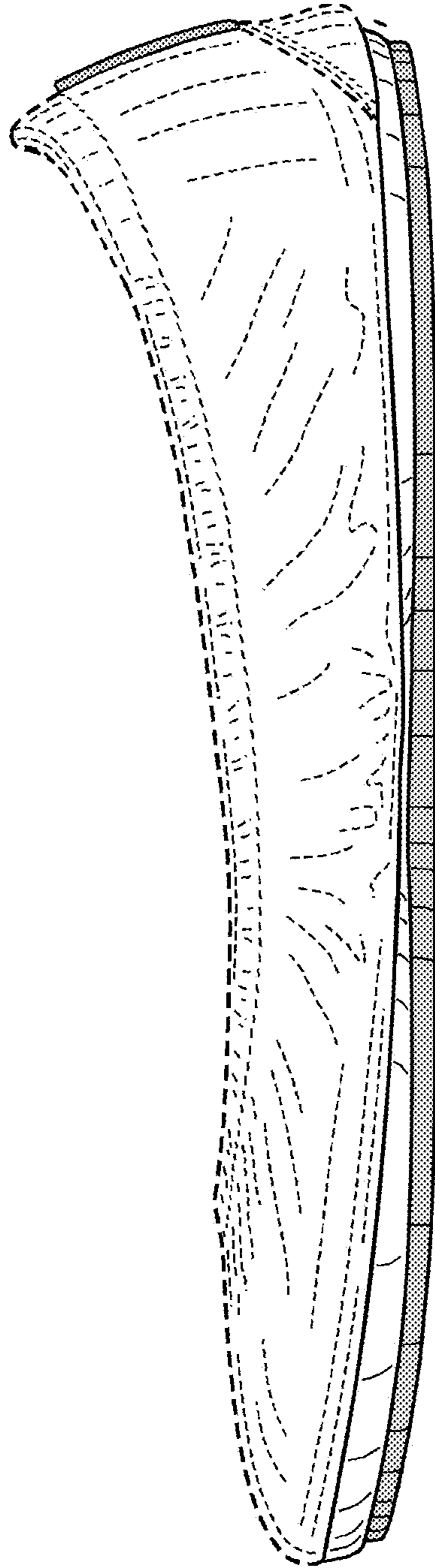

FIG. 38

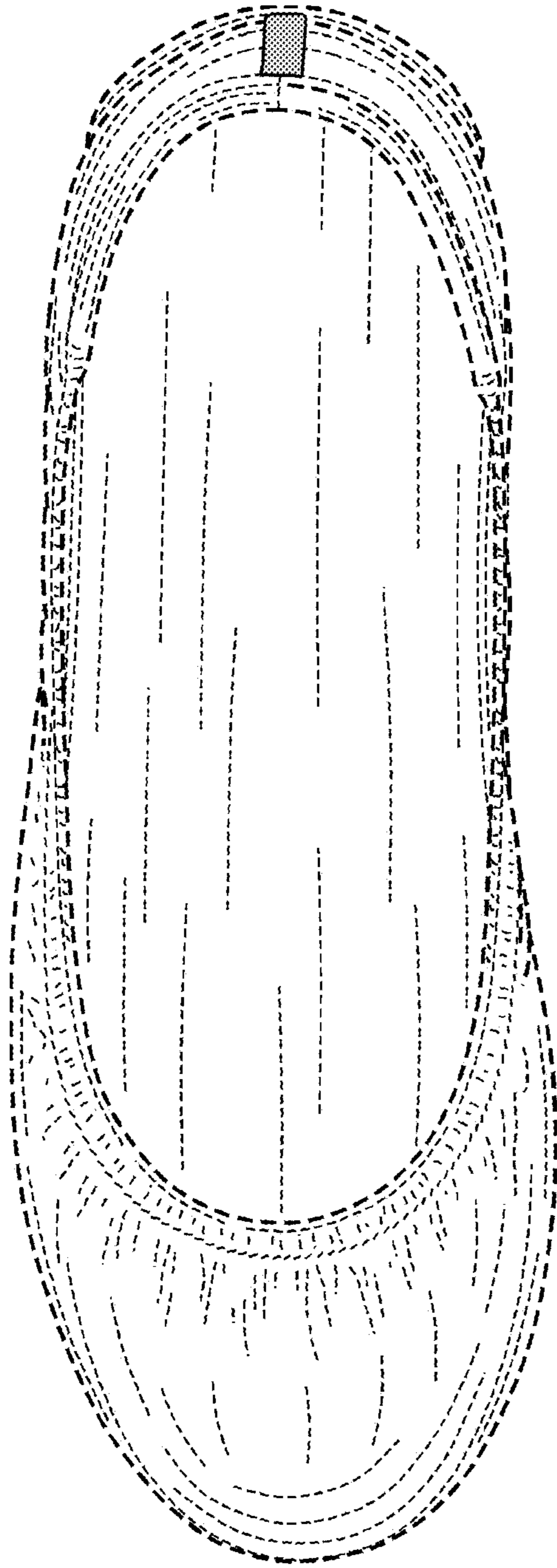

FIG. 39

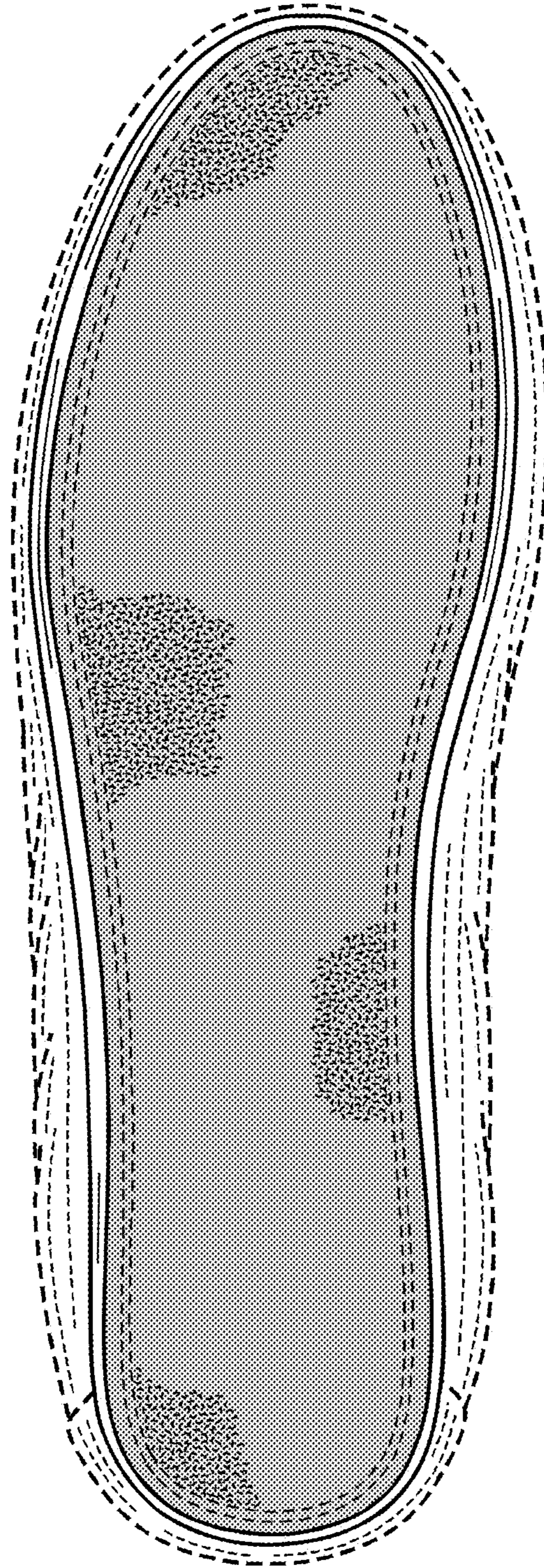

FIG. 40

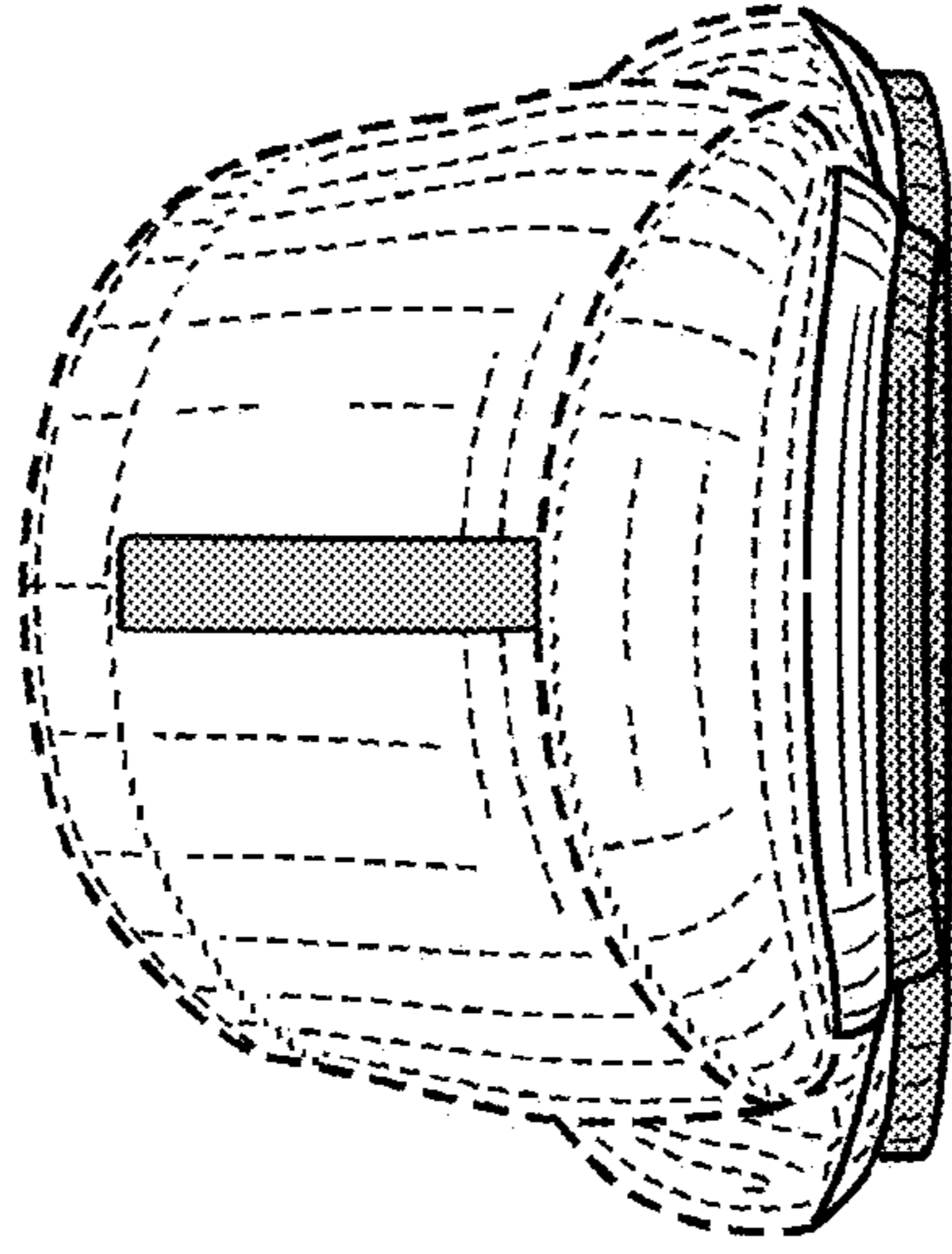

FIG. 42

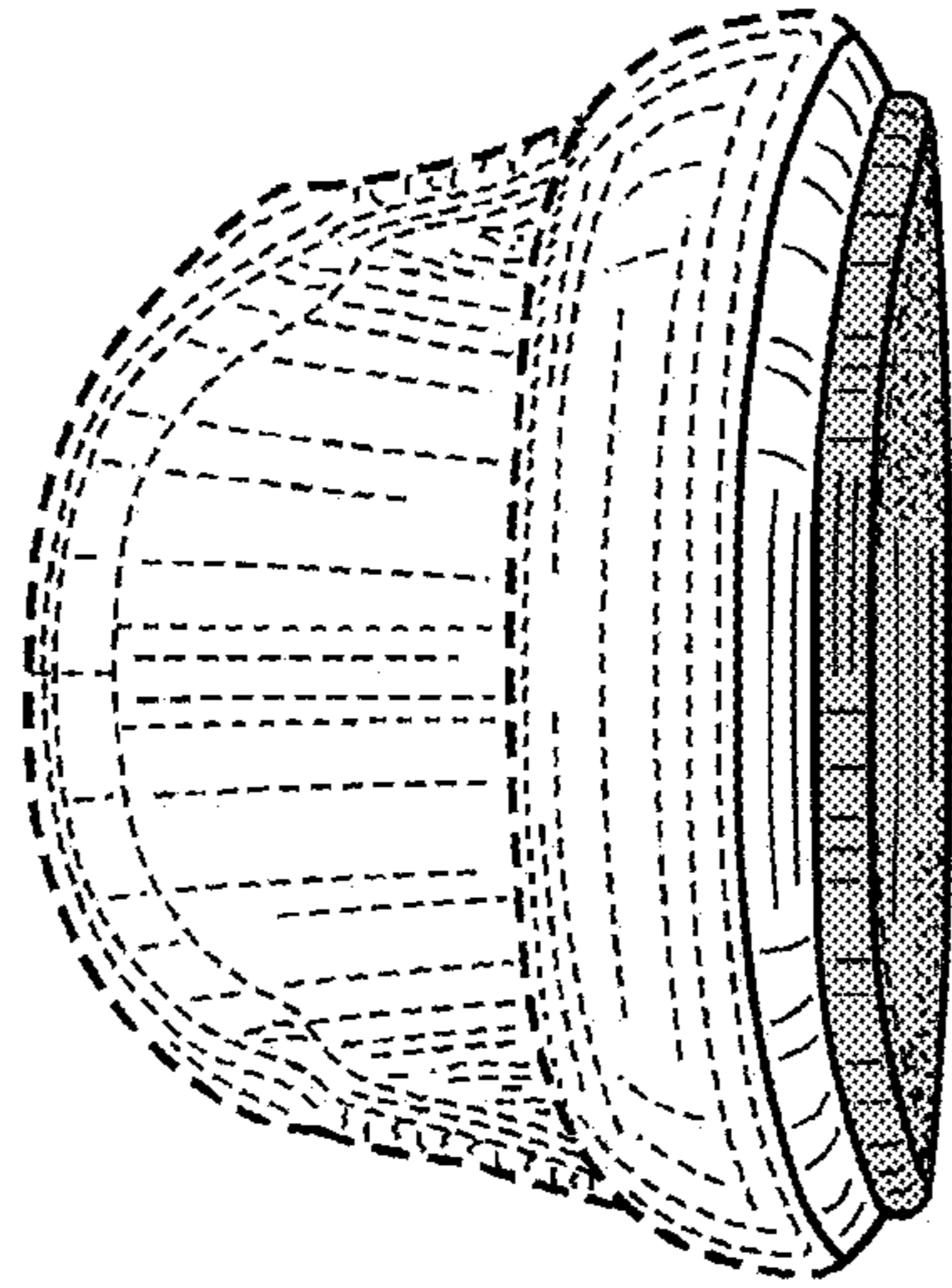

FIG. 41

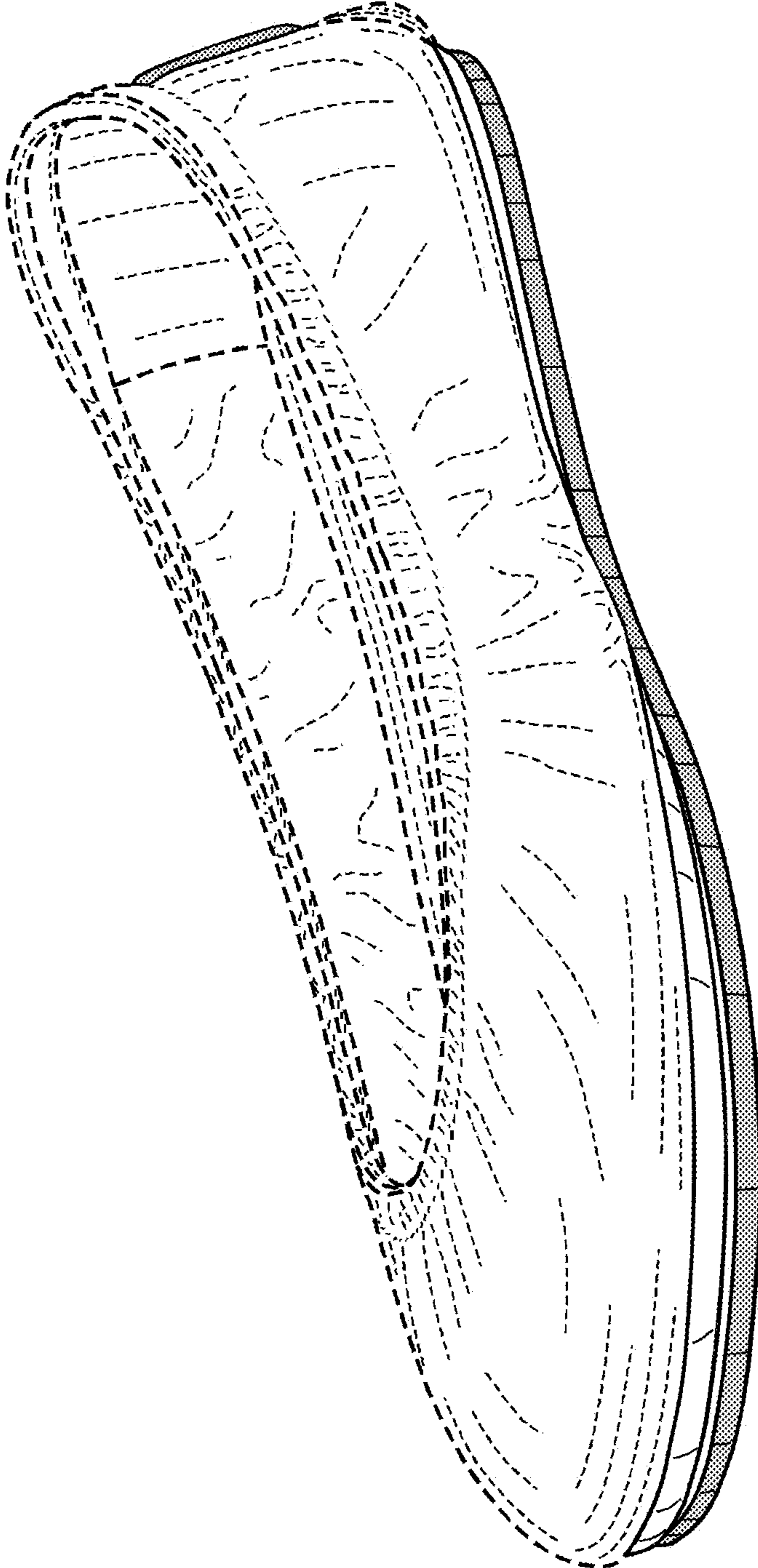

FIG. 43

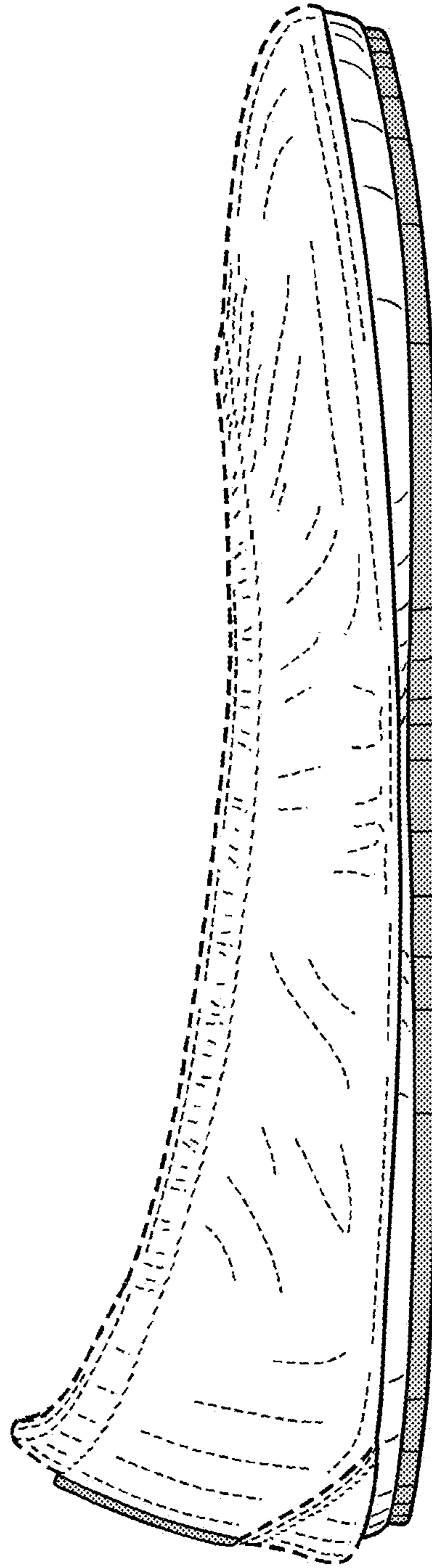

FIG. 44

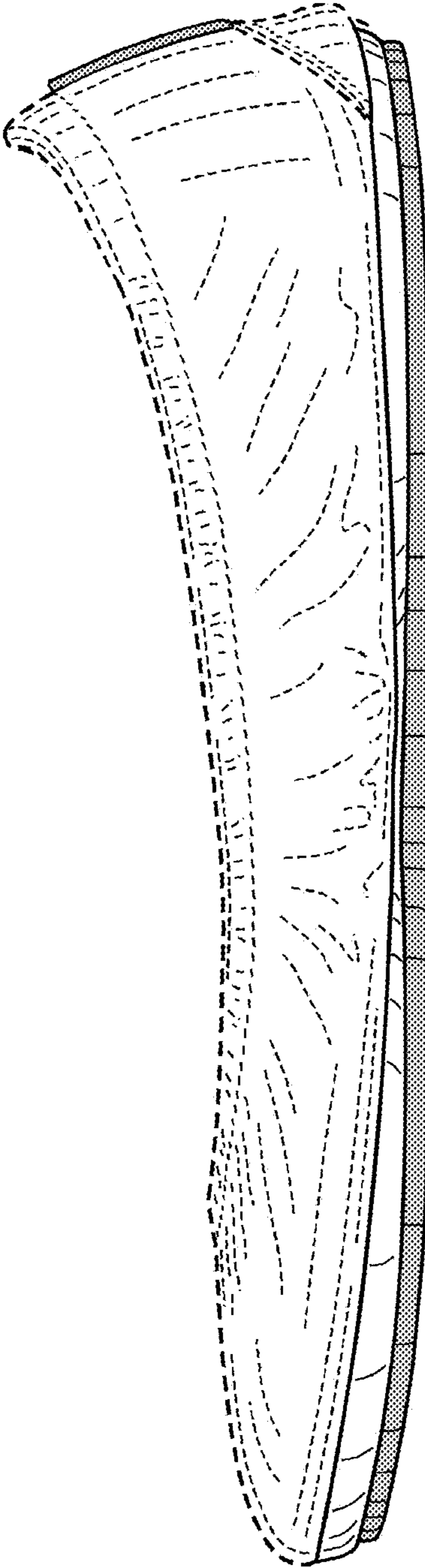

FIG. 45

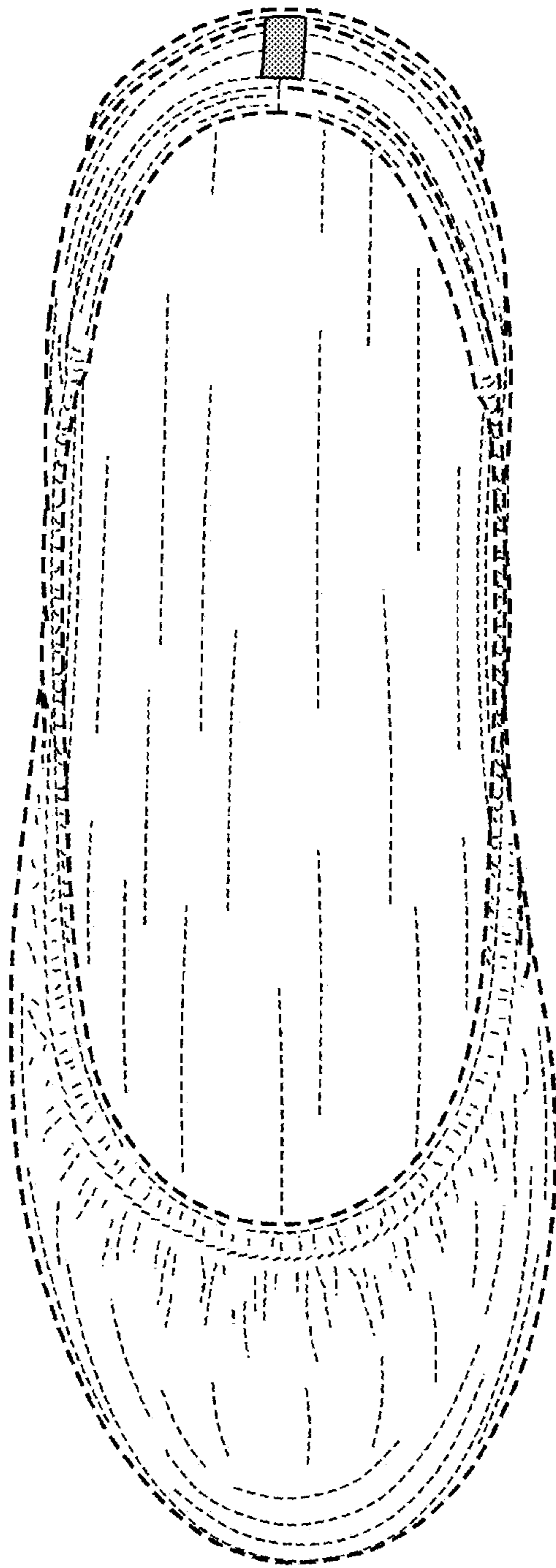

FIG. 46

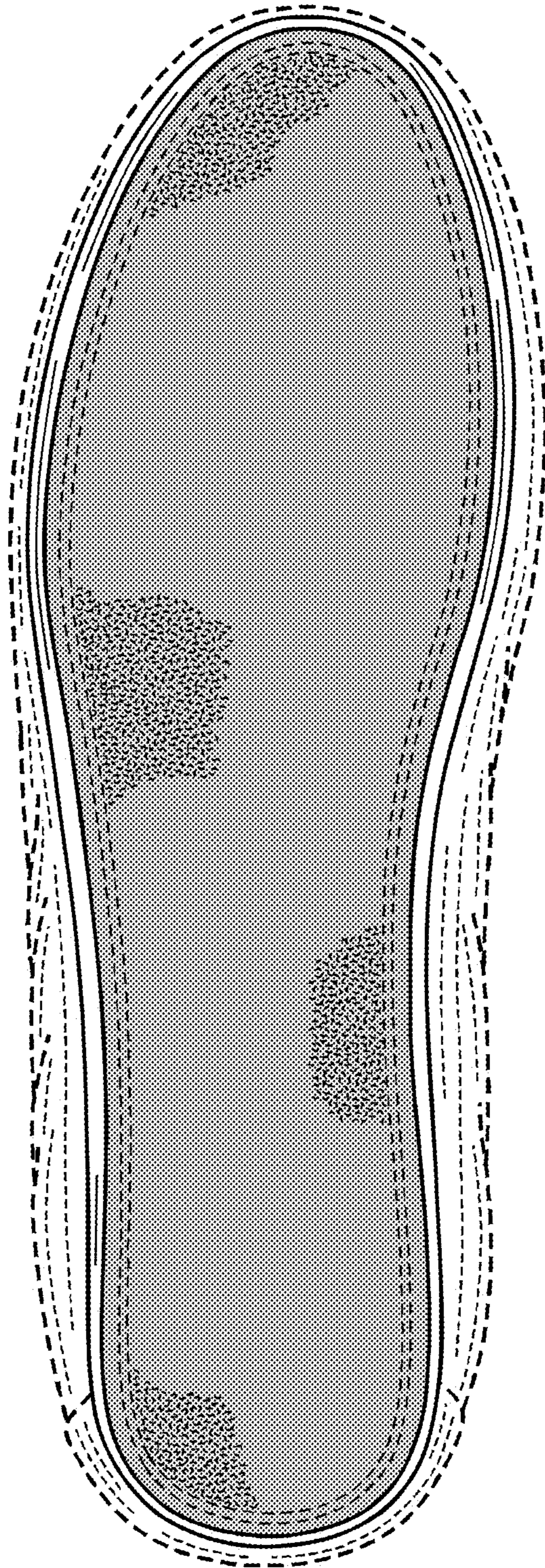

FIG. 47

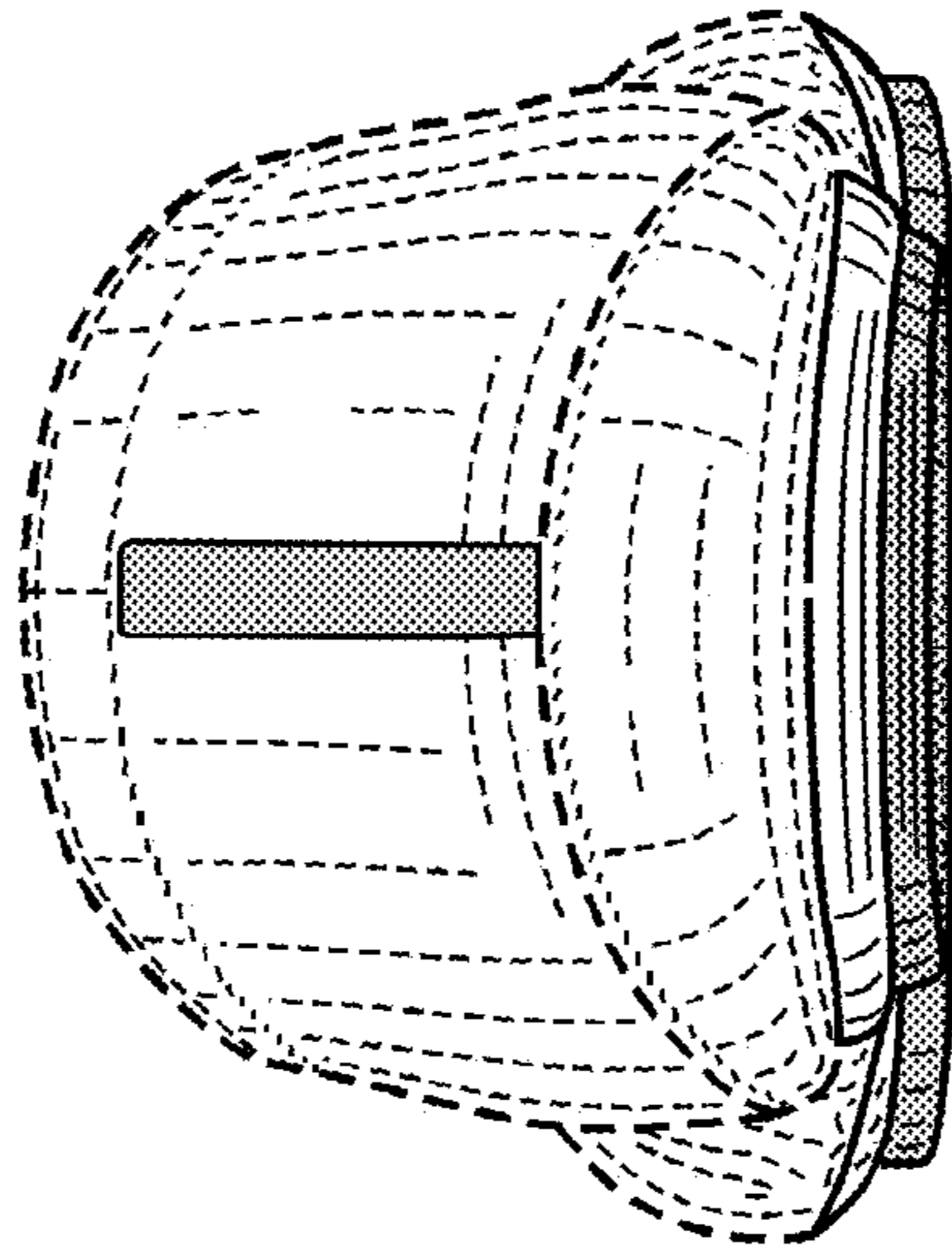

FIG. 49

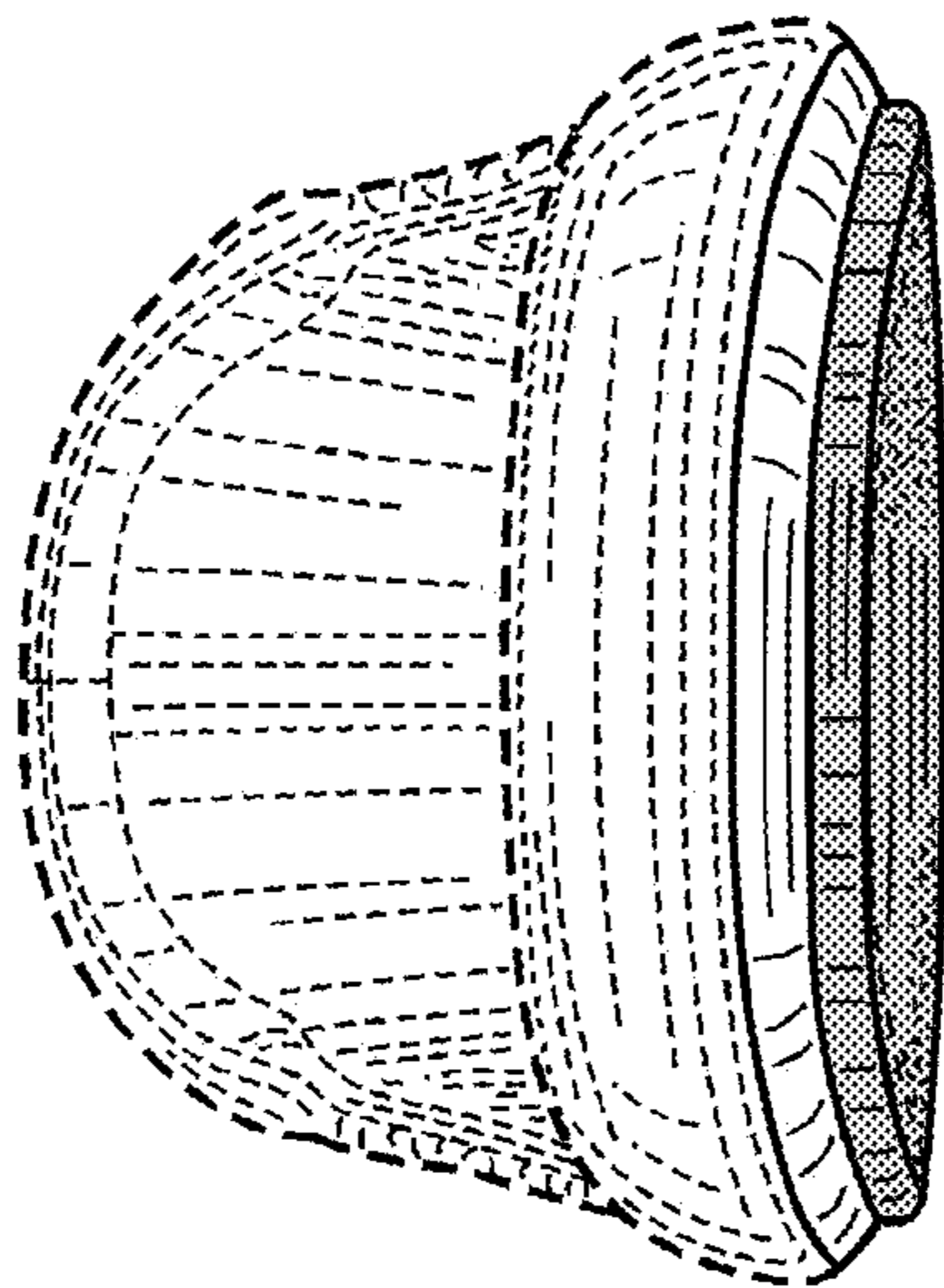

FIG. 48

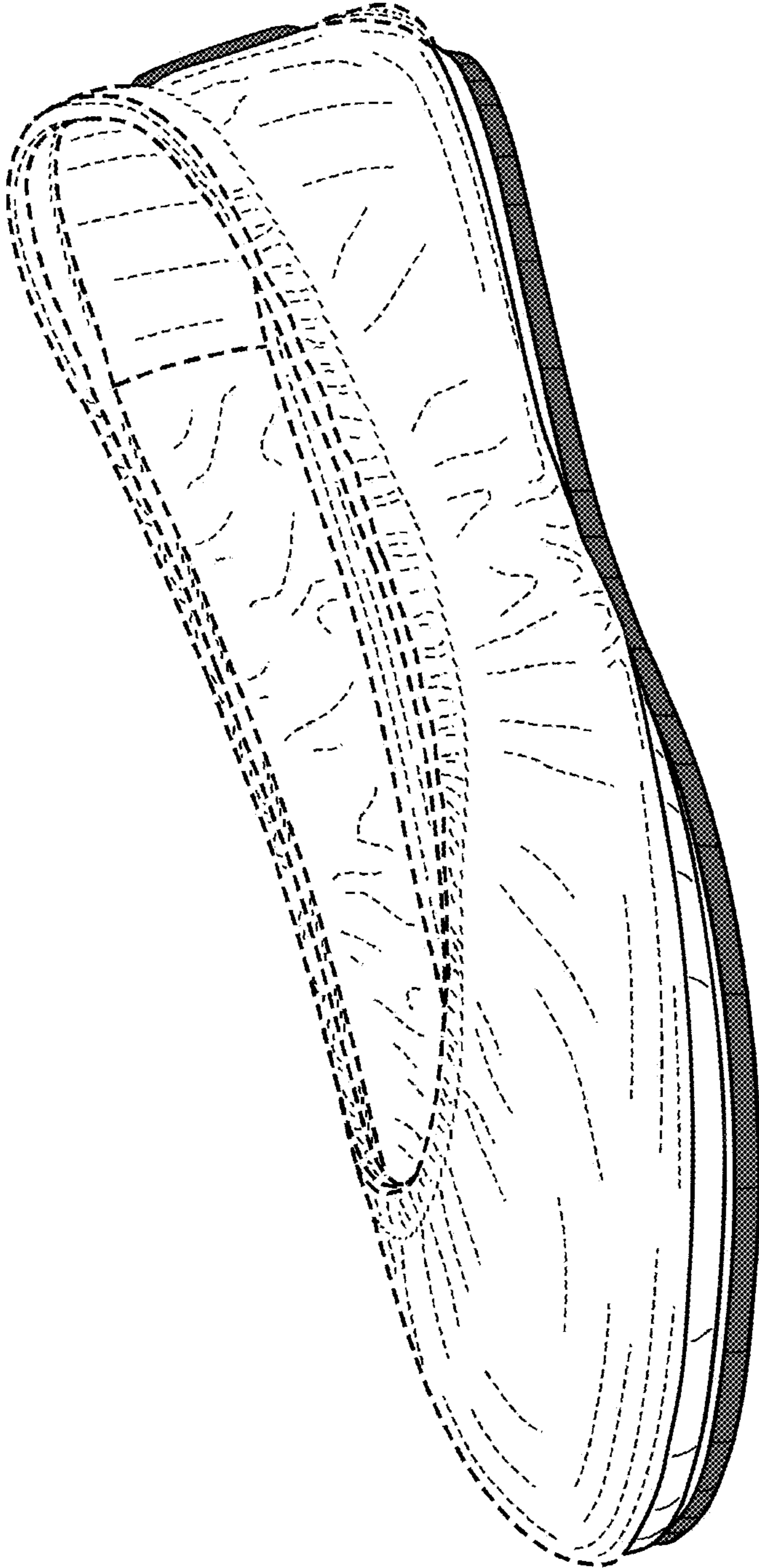

FIG. 50

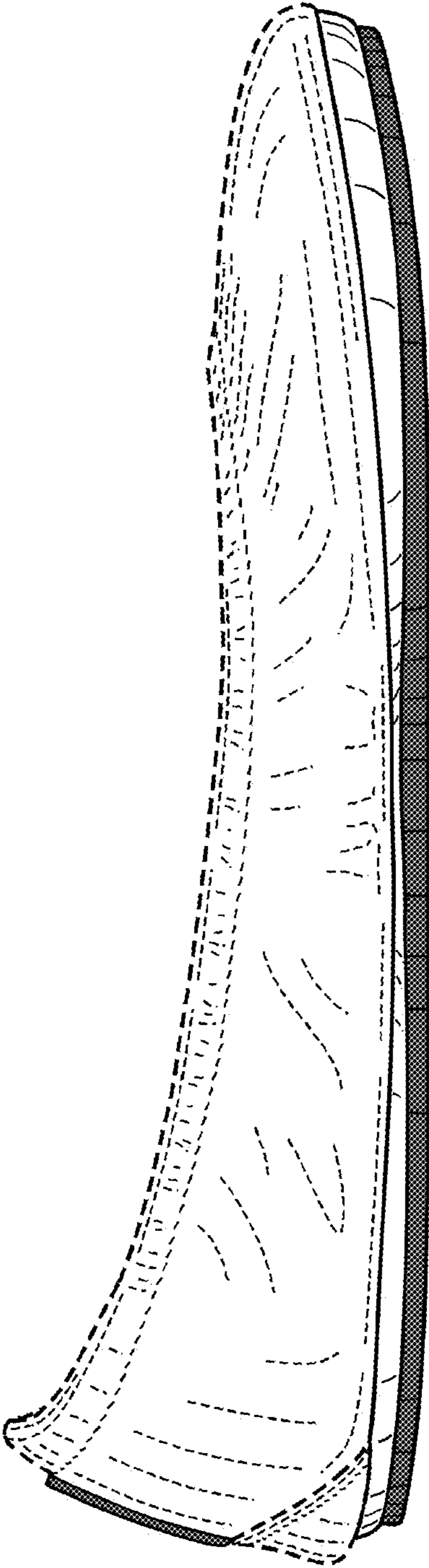

FIG. 51

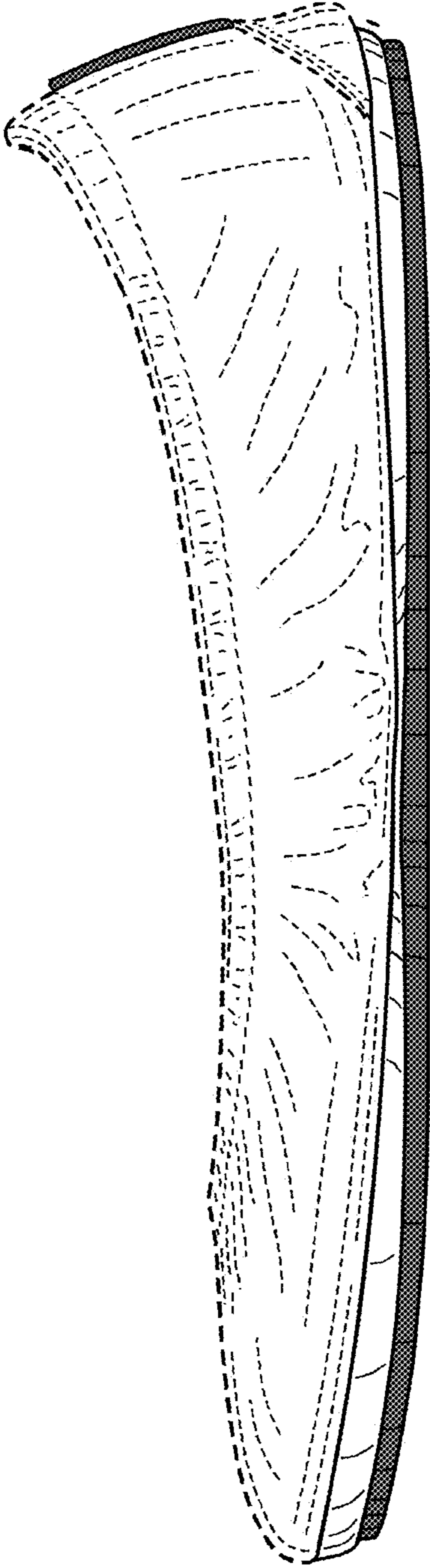

FIG. 52

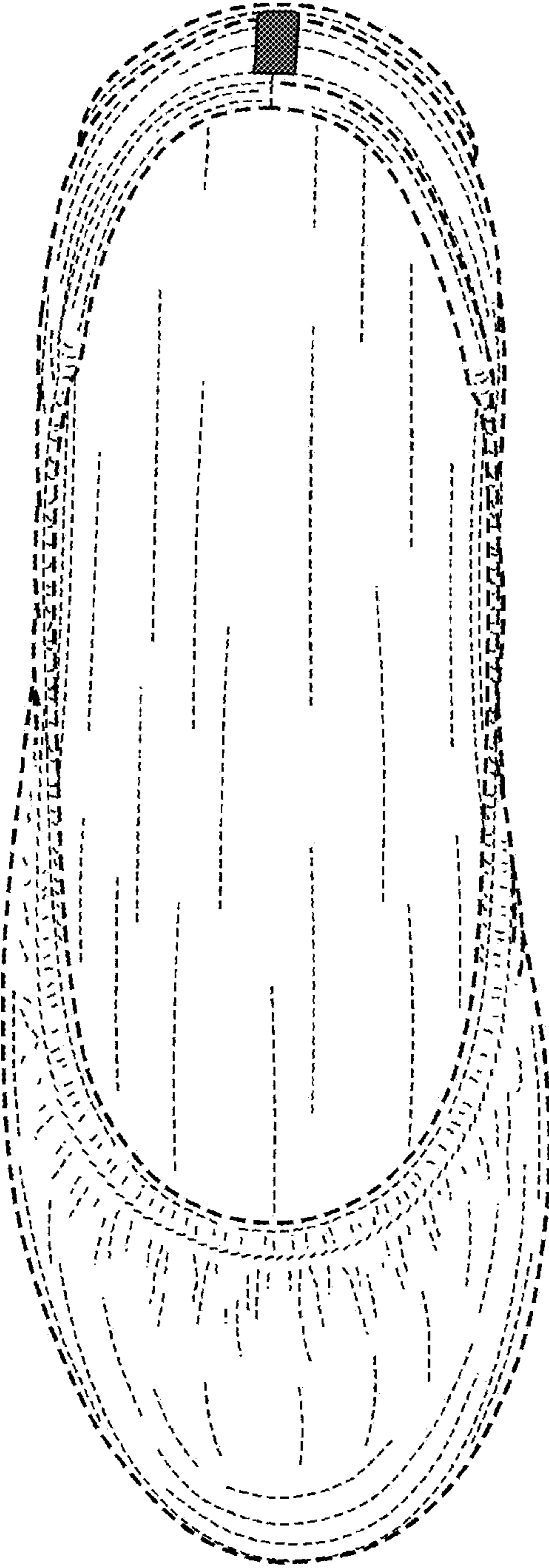

FIG. 53

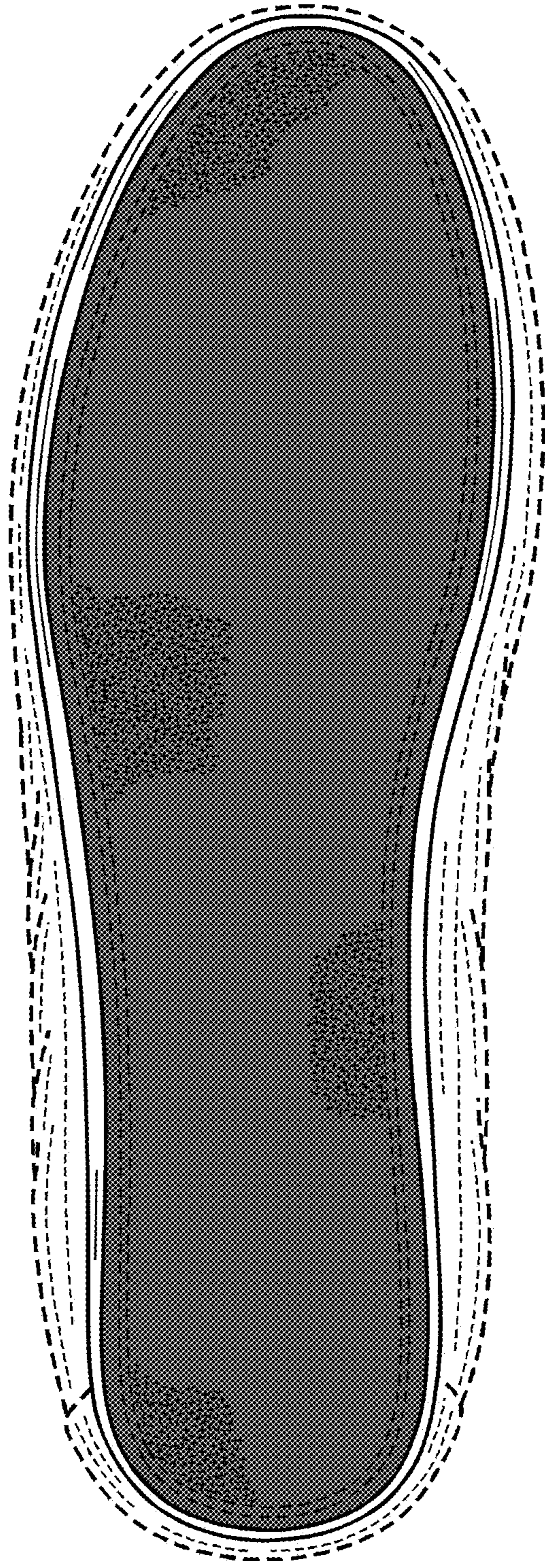

FIG. 54

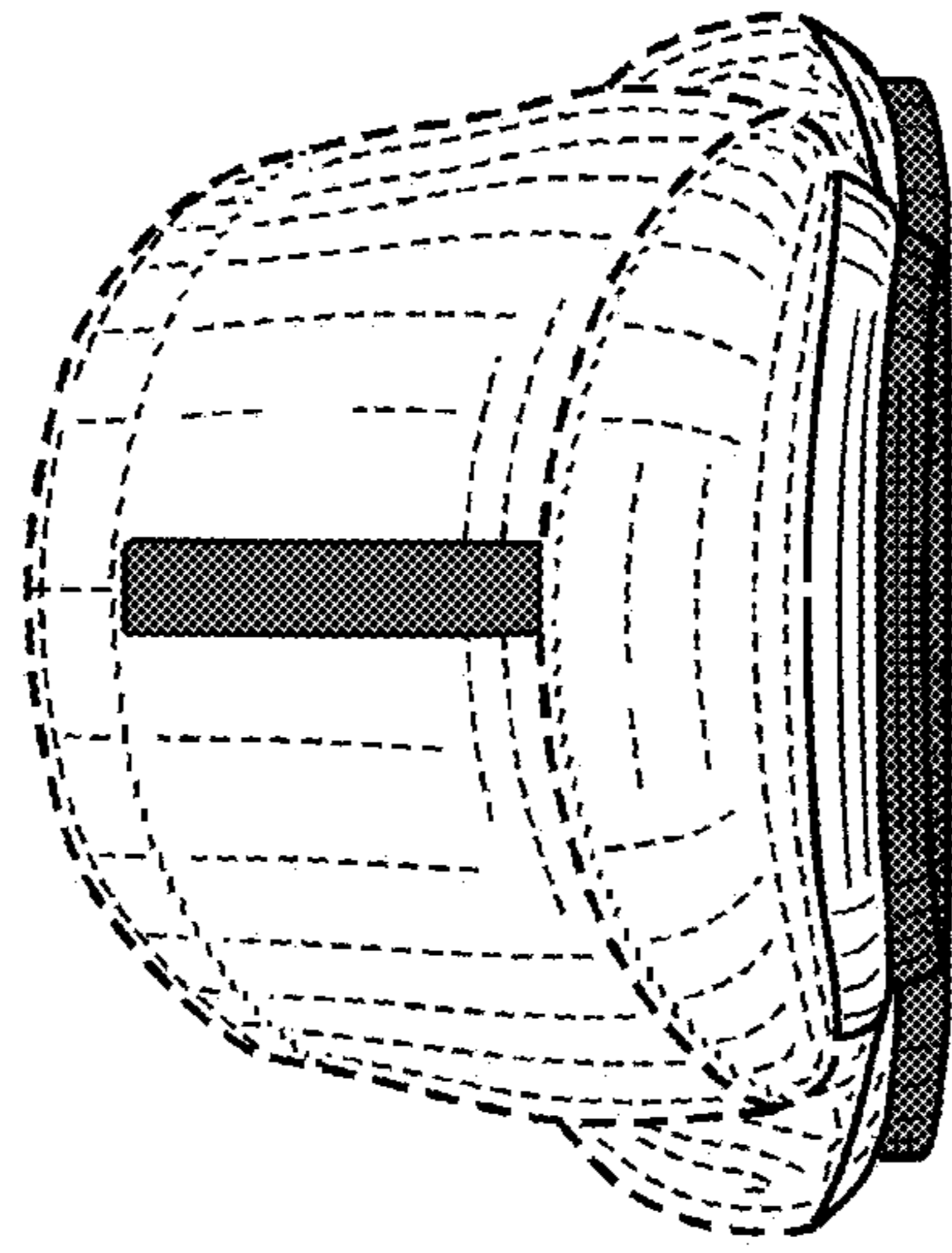

FIG. 56

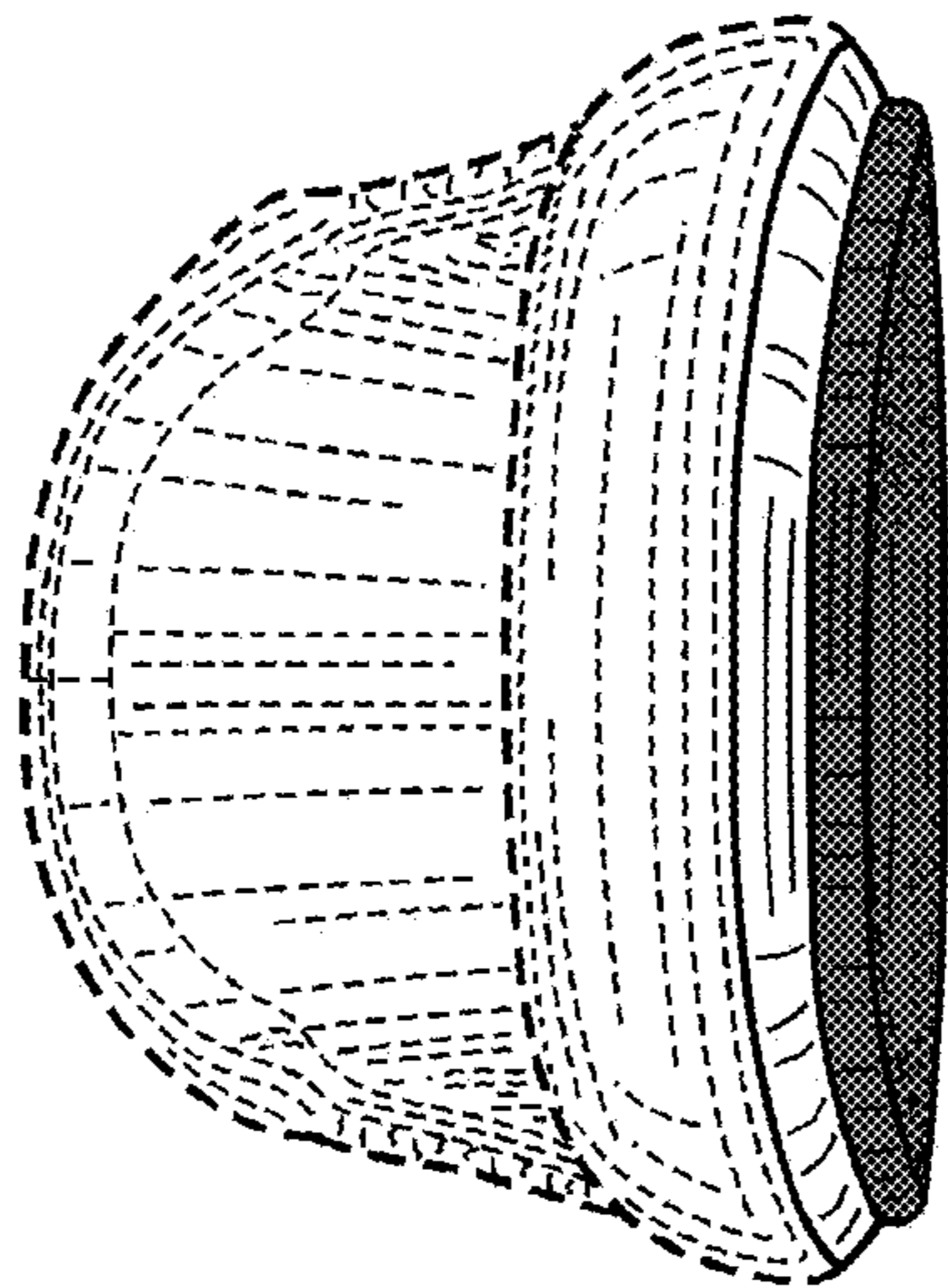

FIG. 55

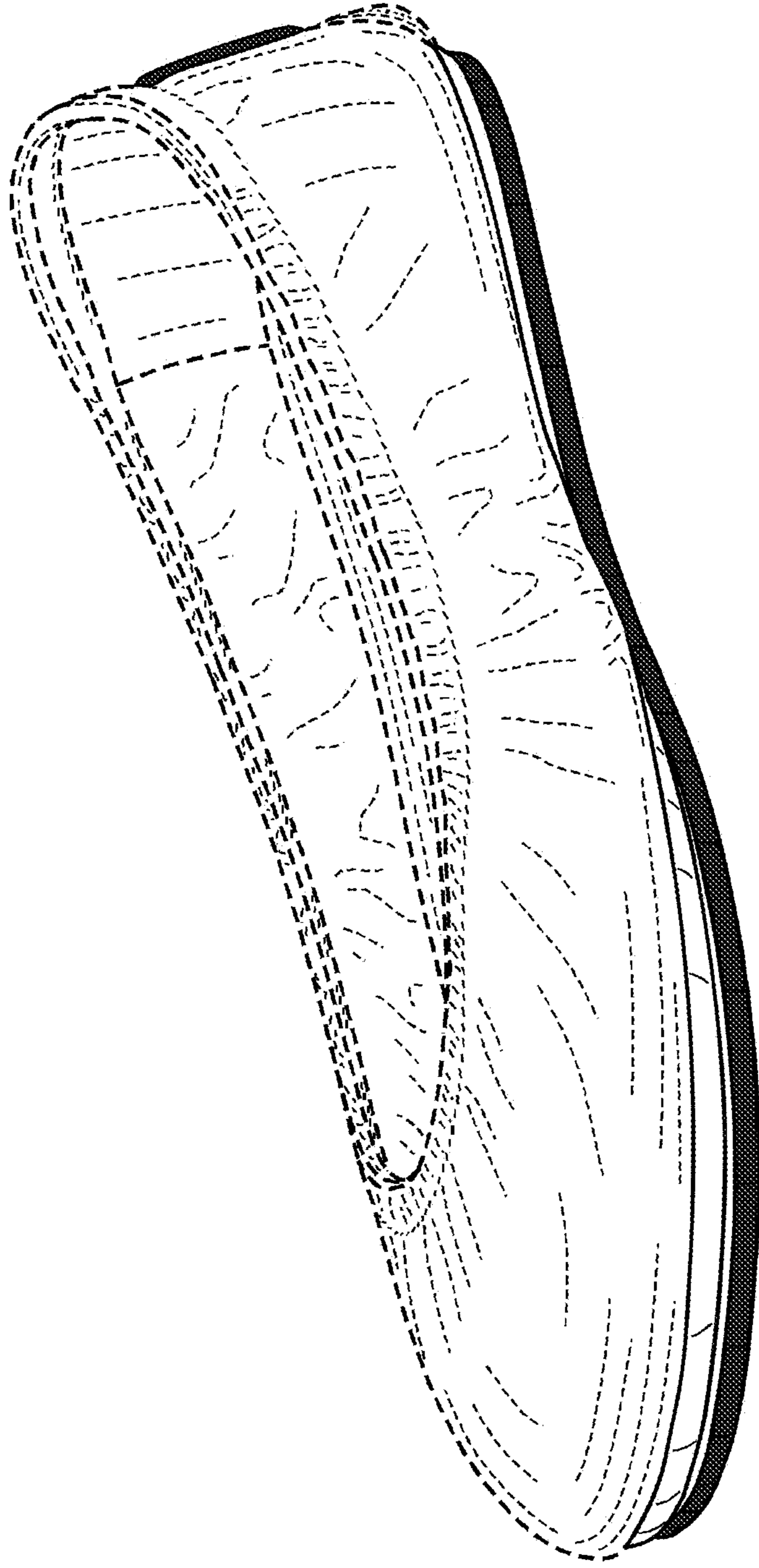

FIG. 57

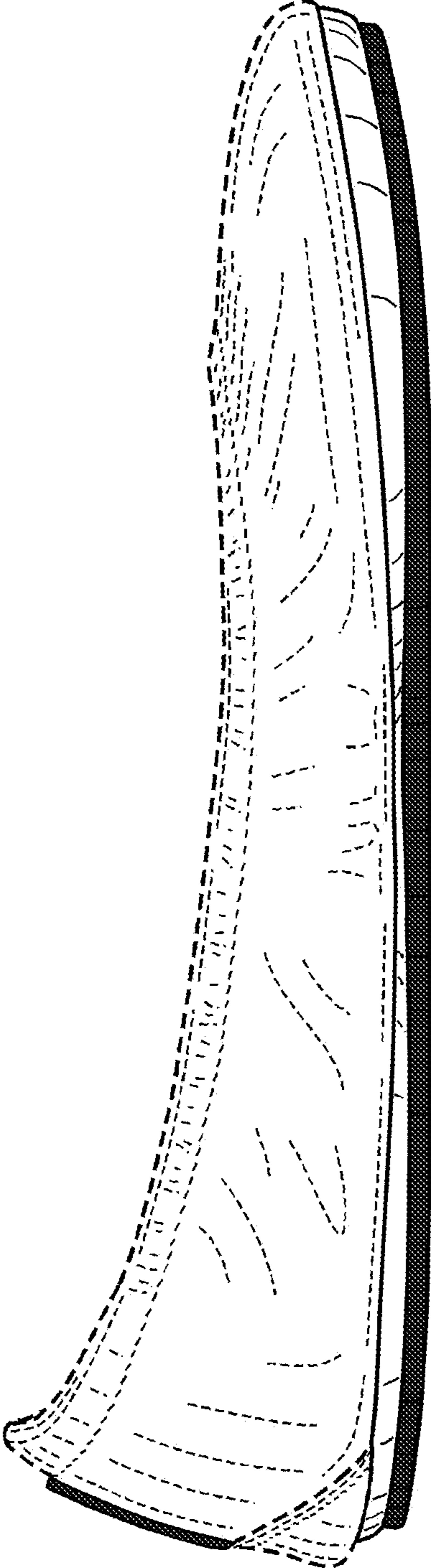

FIG. 58

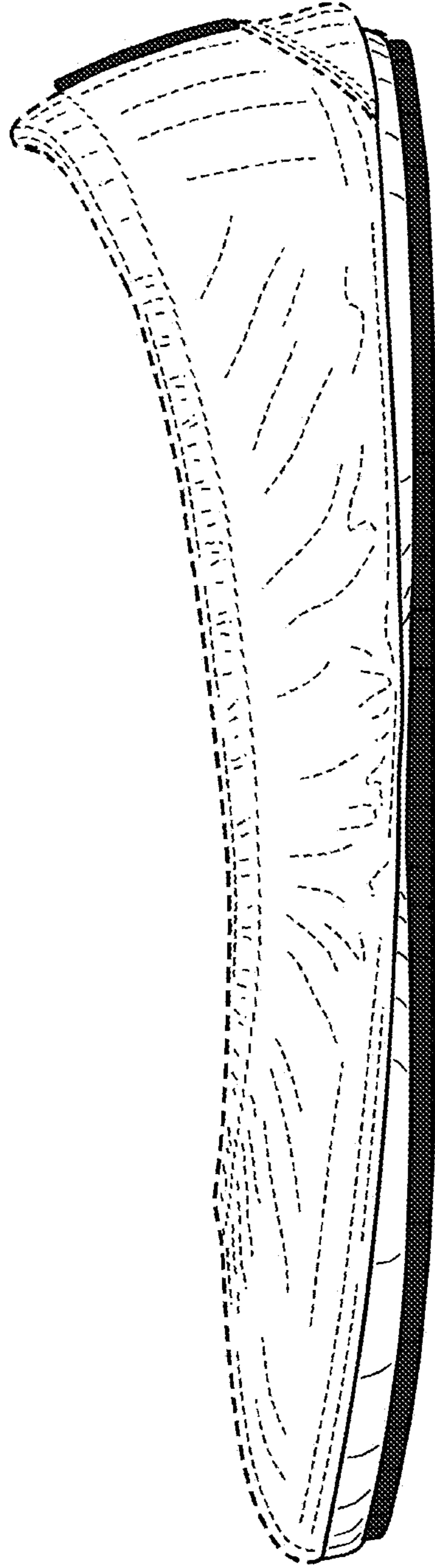

FIG. 59

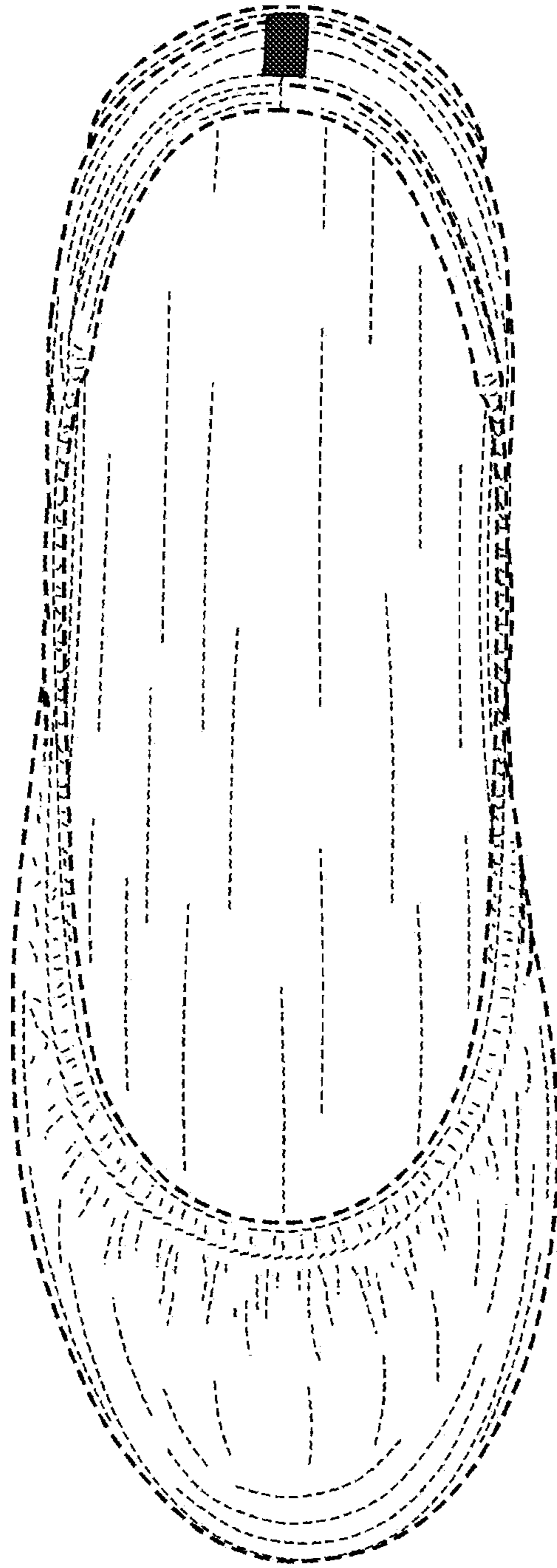

FIG. 60

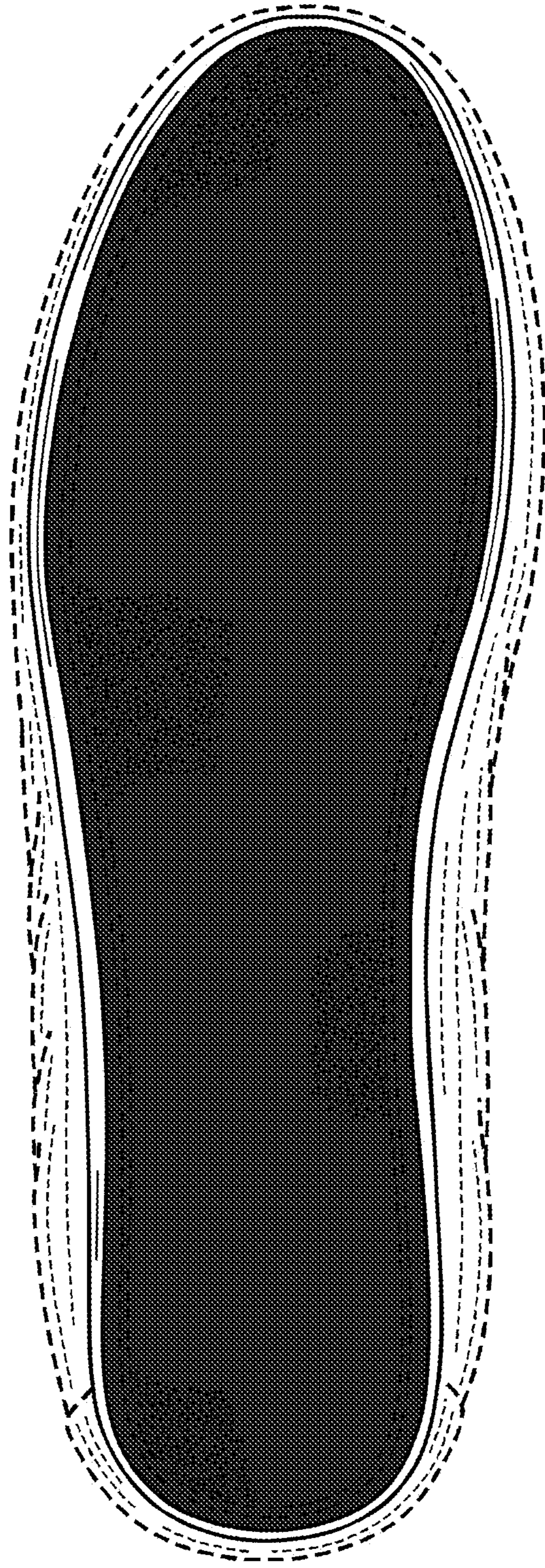

FIG. 61

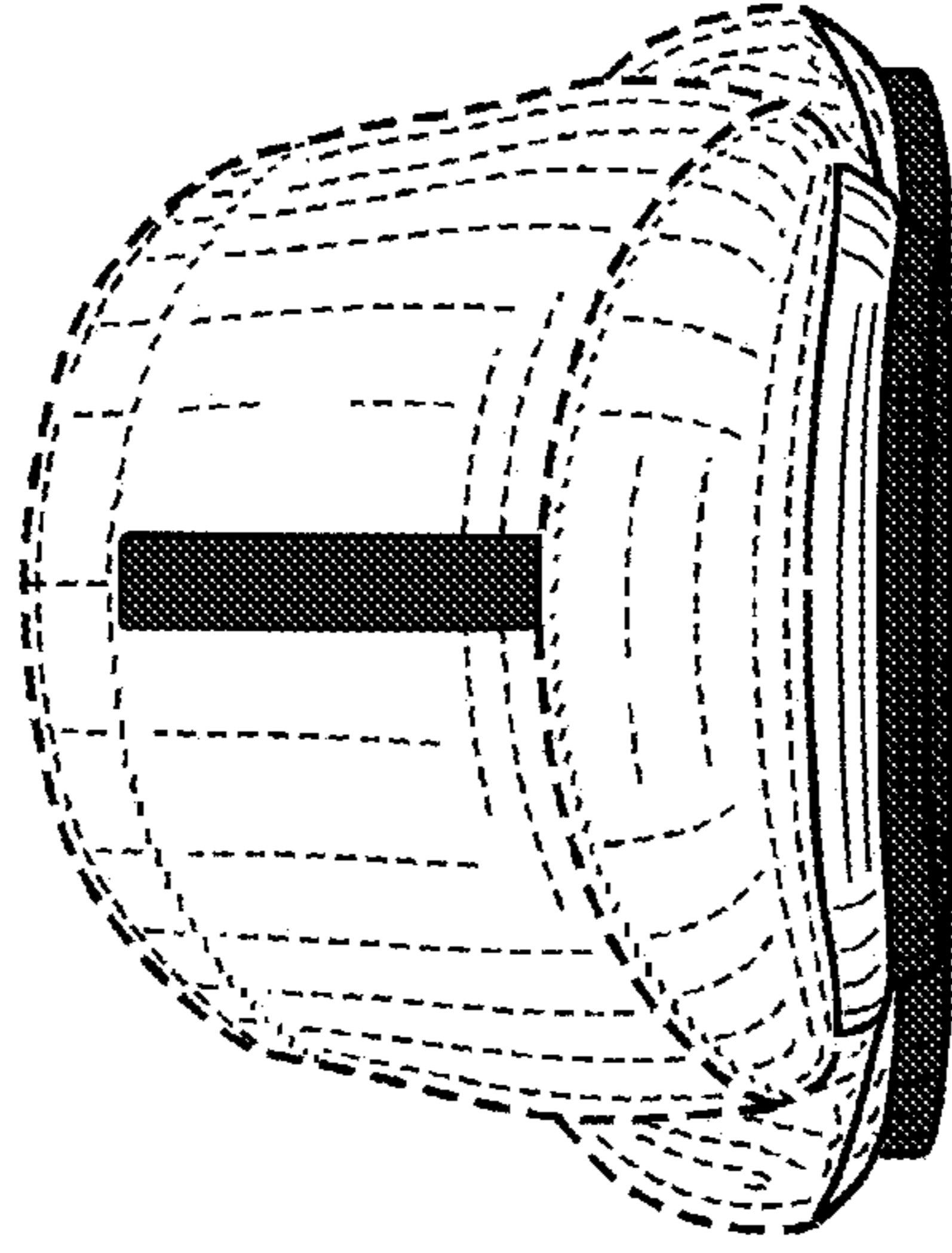

FIG. 63

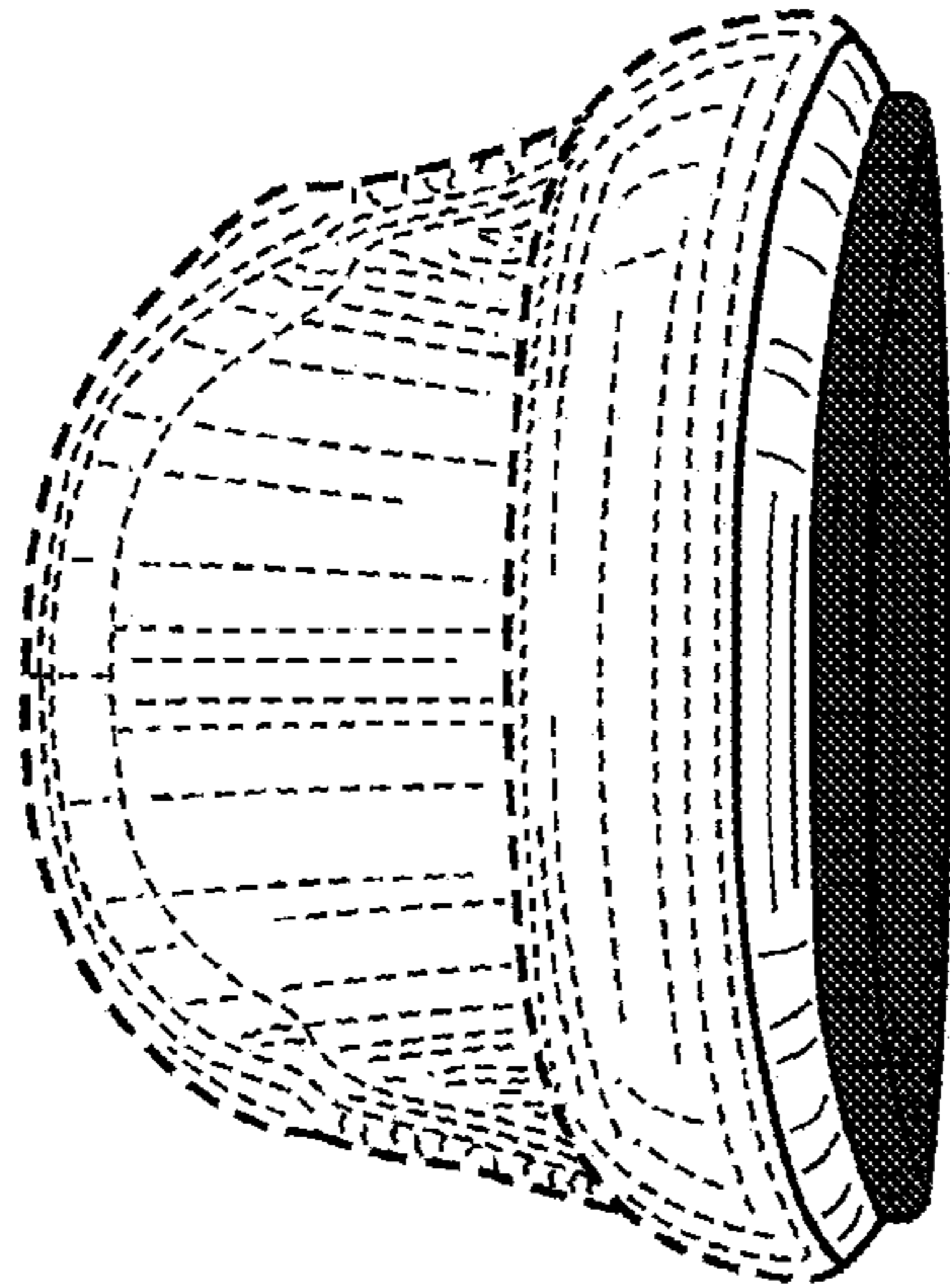

FIG. 62

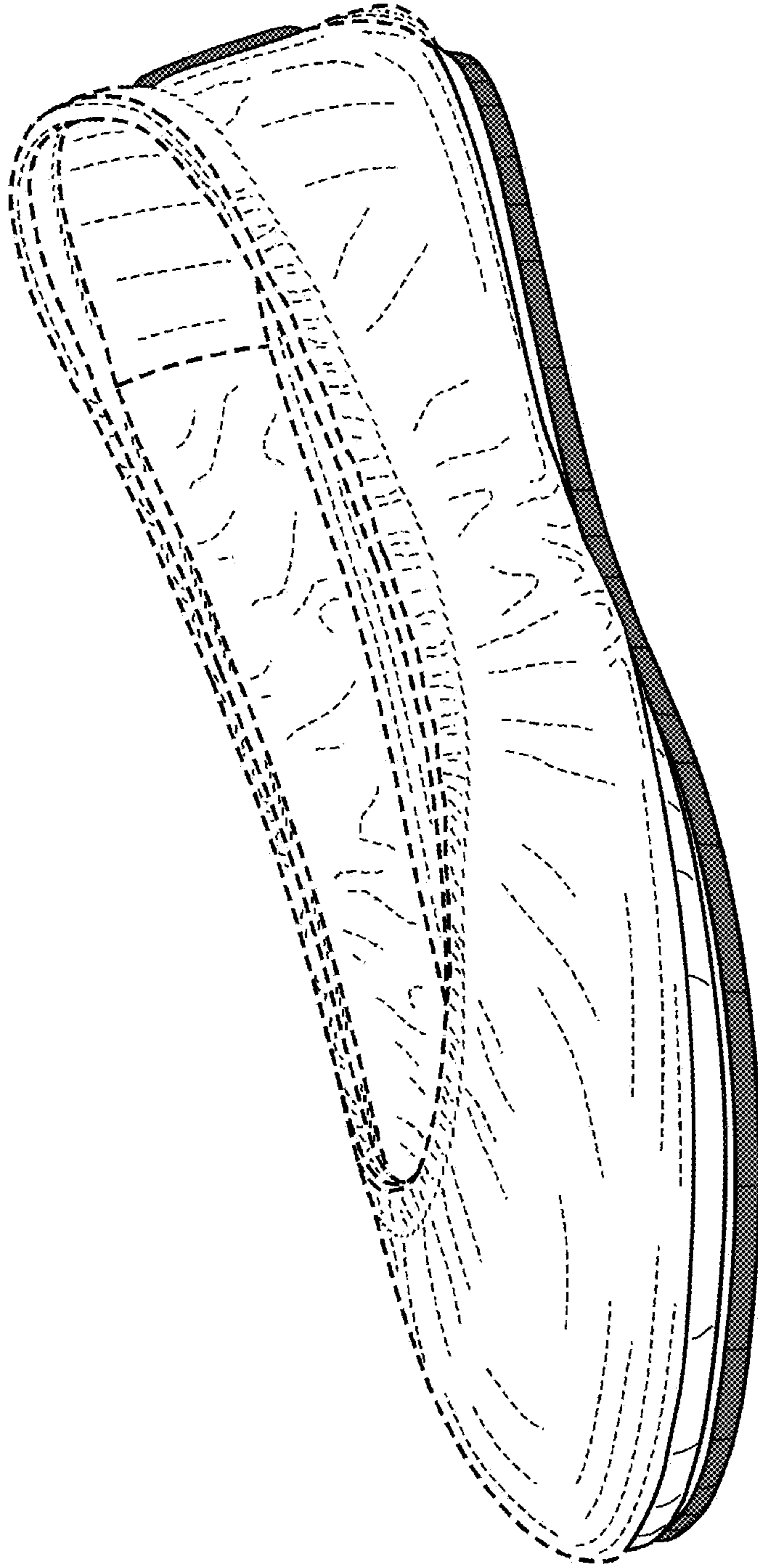

FIG. 64

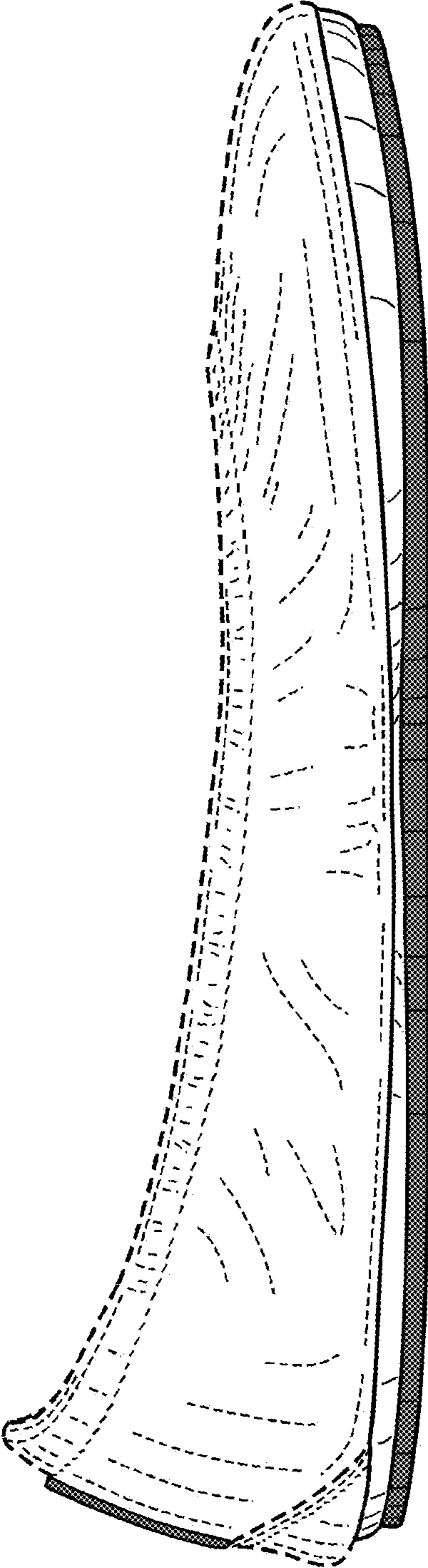

FIG. 65

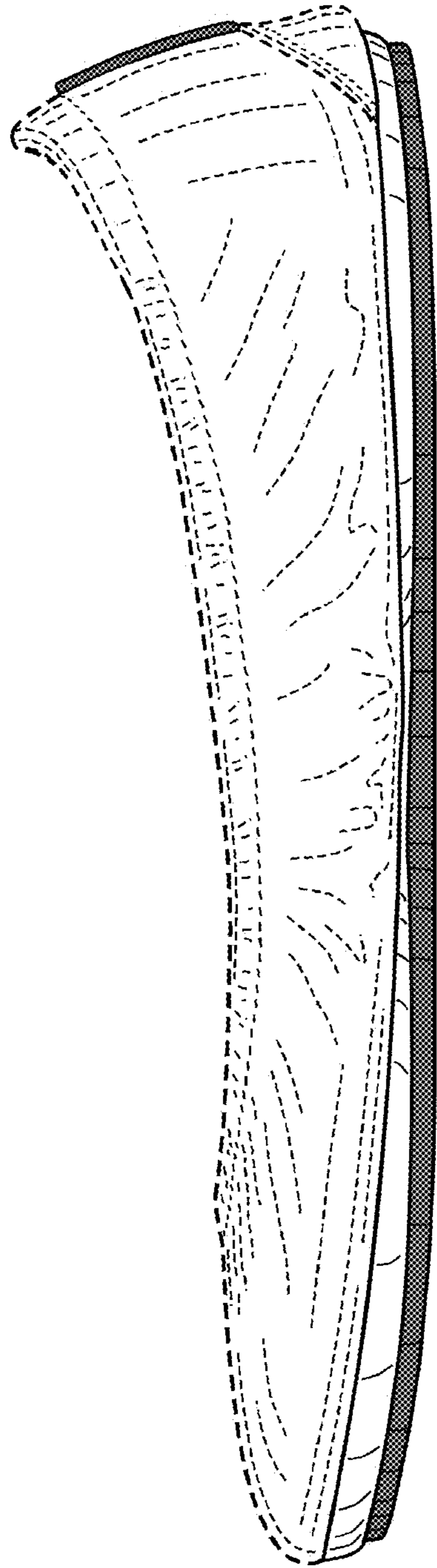

FIG. 66

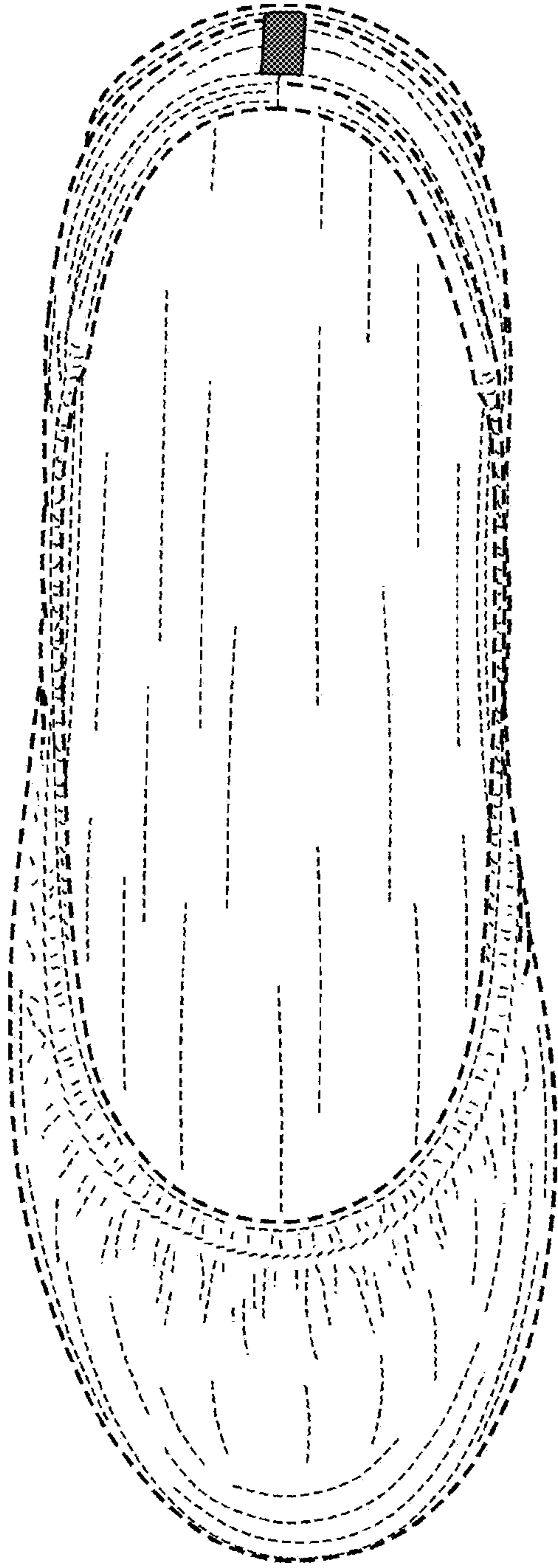

FIG. 67

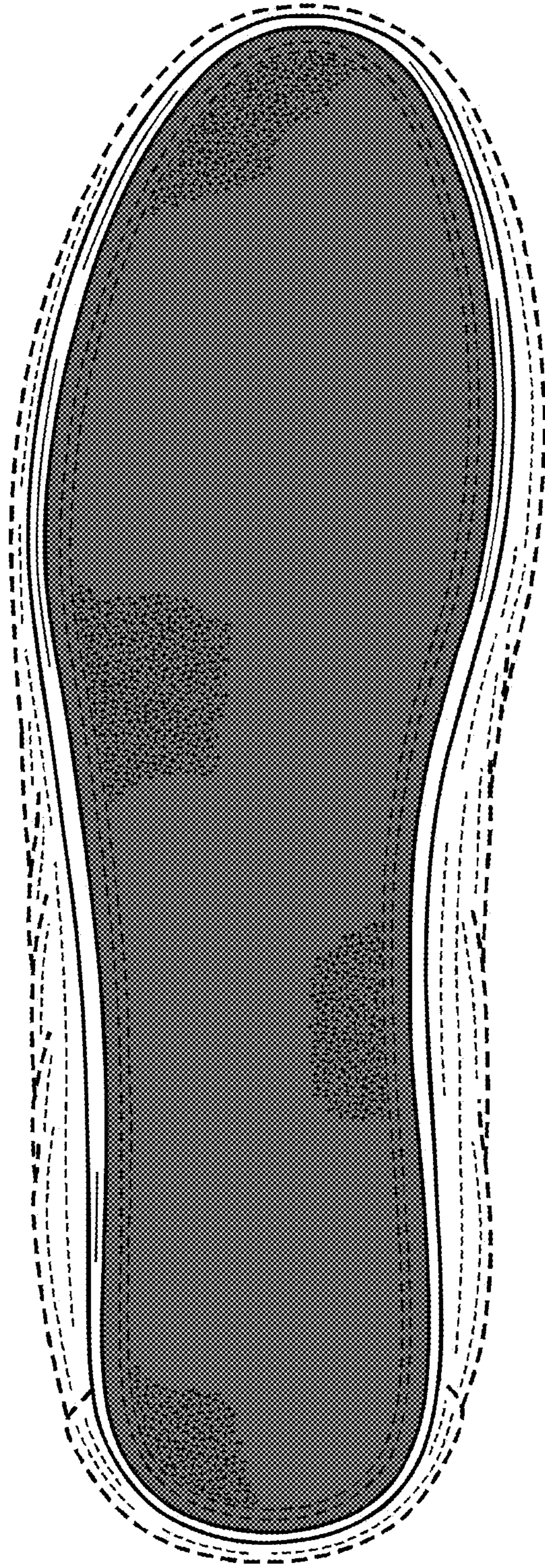

FIG. 68

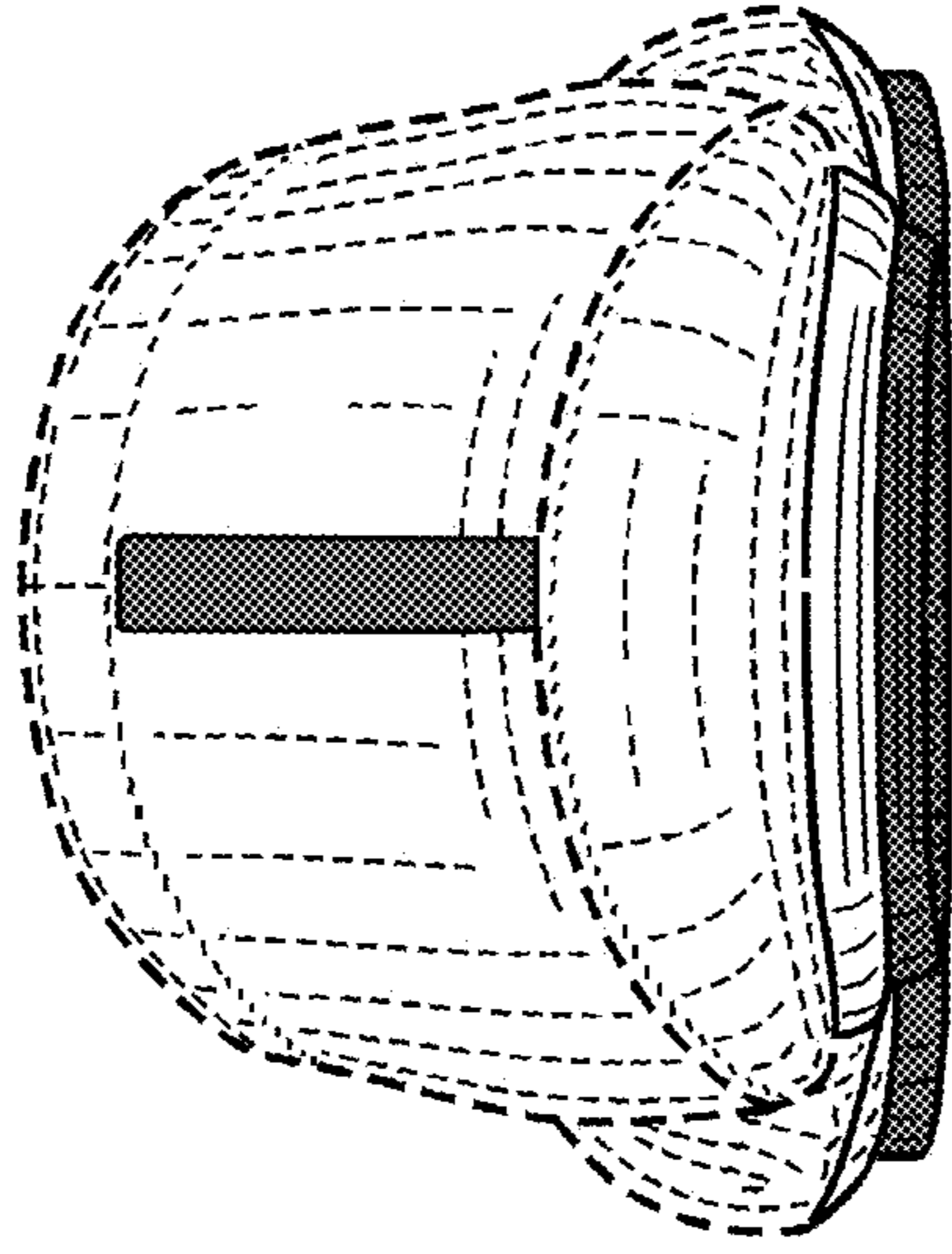

FIG. 69

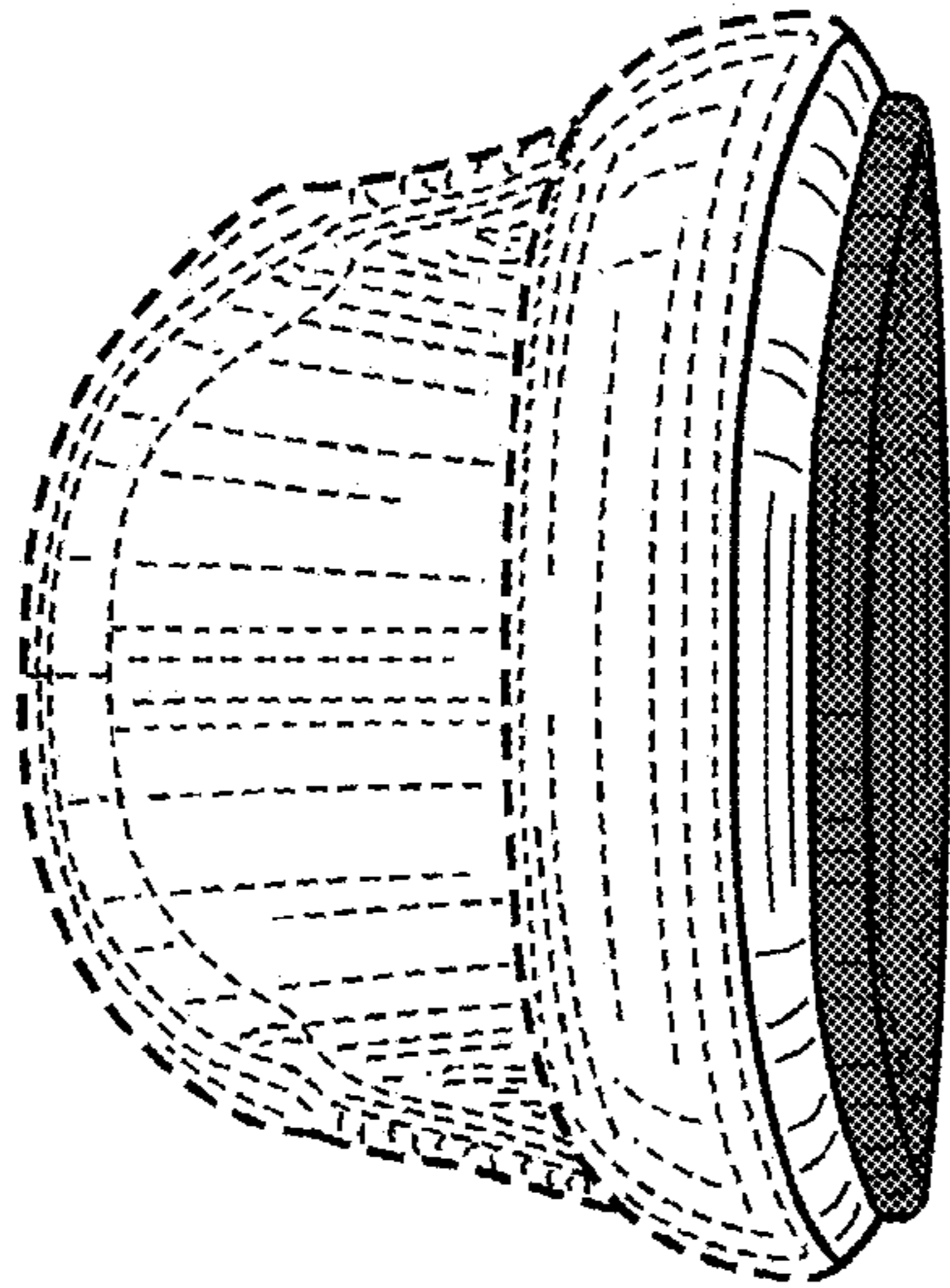

FIG. 70