



US00D901370S

(12) **United States Design Patent** (10) **Patent No.:** **US D901,370 S**
Liesener et al. (45) **Date of Patent:** **** Nov. 10, 2020**

(54) **AUTONOMOUS VEHICLE**

(56) **References Cited**

(71) Applicant: **MOTHERSON INNOVATIONS COMPANY LIMITED**, London (GB)

U.S. PATENT DOCUMENTS

(72) Inventors: **Alf Liesener**, Ramshalden (DE);
Stefanie Göttlicher, Stuttgart (DE);
Rustam Schogenow, Weissach-Flacht (DE); **Romain Friot**, Weissach-Flacht (DE); **Manuela Schuster**, Weissach-Flacht (DE); **Steve Emter**, Weissach-Flacht (DE); **Lorenz Weiß**, Weissach-Flacht (DE); **Shuyong Liu**, Weissach-Flacht (DE); **Sabrina Walz**, Weissach-Flacht (DE); **Femke Piening**, Weissach-Flacht (DE)

D610,504 S	*	2/2010	Bucher	D12/169
D751,004 S	*	3/2016	Rupar	D12/163
D811,963 S	*	3/2018	Sullivan	D12/169
D813,744 S	*	3/2018	Whitla	D12/169
D813,754 S	*	3/2018	Loeb	D12/169
D816,563 S	*	5/2018	McMahan	D12/169
D819,524 S	*	6/2018	Behmer	D12/169
D822,556 S	*	7/2018	Platto	D12/169
D832,157 S	*	10/2018	Svensson	D12/169
D838,636 S	*	1/2019	Behmer	D12/169
D842,771 S	*	3/2019	Nishii	D12/169
D878,256 S	*	3/2020	Kim	D12/169

* cited by examiner

Primary Examiner — Katrina A Betton

(74) *Attorney, Agent, or Firm* — Jones Day

(73) Assignee: **Motherson Innovations Company Limited**, London (GB)

(57) **CLAIM**

The ornamental design for an autonomous vehicle, as shown and described.

(**) Term: **15 Years**

DESCRIPTION

(21) Appl. No.: **29/632,670**

FIG. 1 is a front view of an autonomous vehicle in accordance with the present design;
FIG. 2 is a rear view thereof;
FIG. 3 is a side elevational view thereof;
FIG. 4 is a top elevational view thereof;
FIG. 5 is a rear perspective view thereof; and,
FIG. 6 is a front perspective view thereof.
The broken lines depict portions of the autonomous vehicle that form no part of the claimed design.

(22) Filed: **Jan. 9, 2018**

(51) **LOC (12) Cl.** **12-16**

(52) **U.S. Cl.**
USPC **D12/400**

(58) **Field of Classification Search**
USPC D12/400
CPC B60R 21/045
See application file for complete search history.

1 Claim, 3 Drawing Sheets

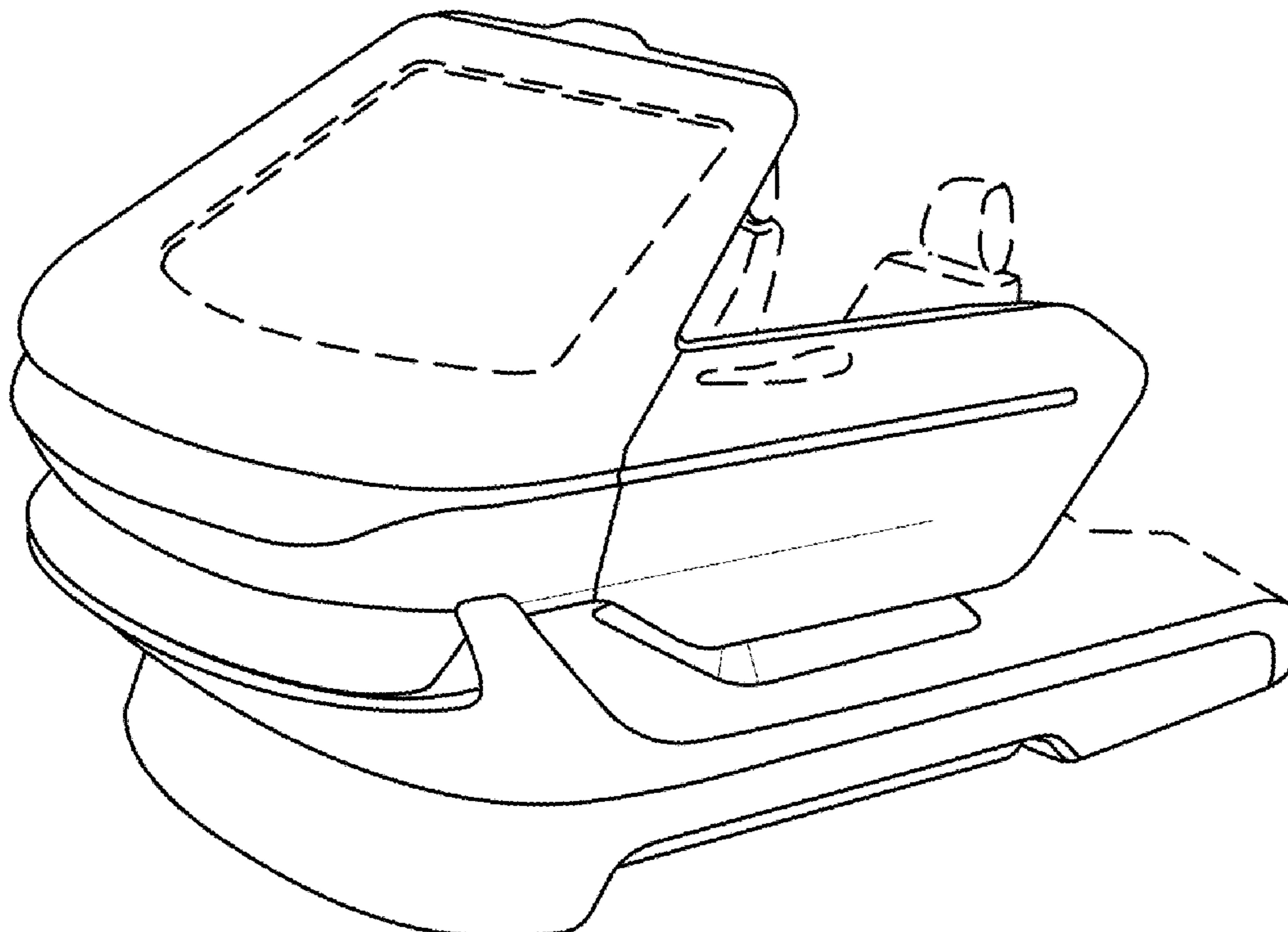

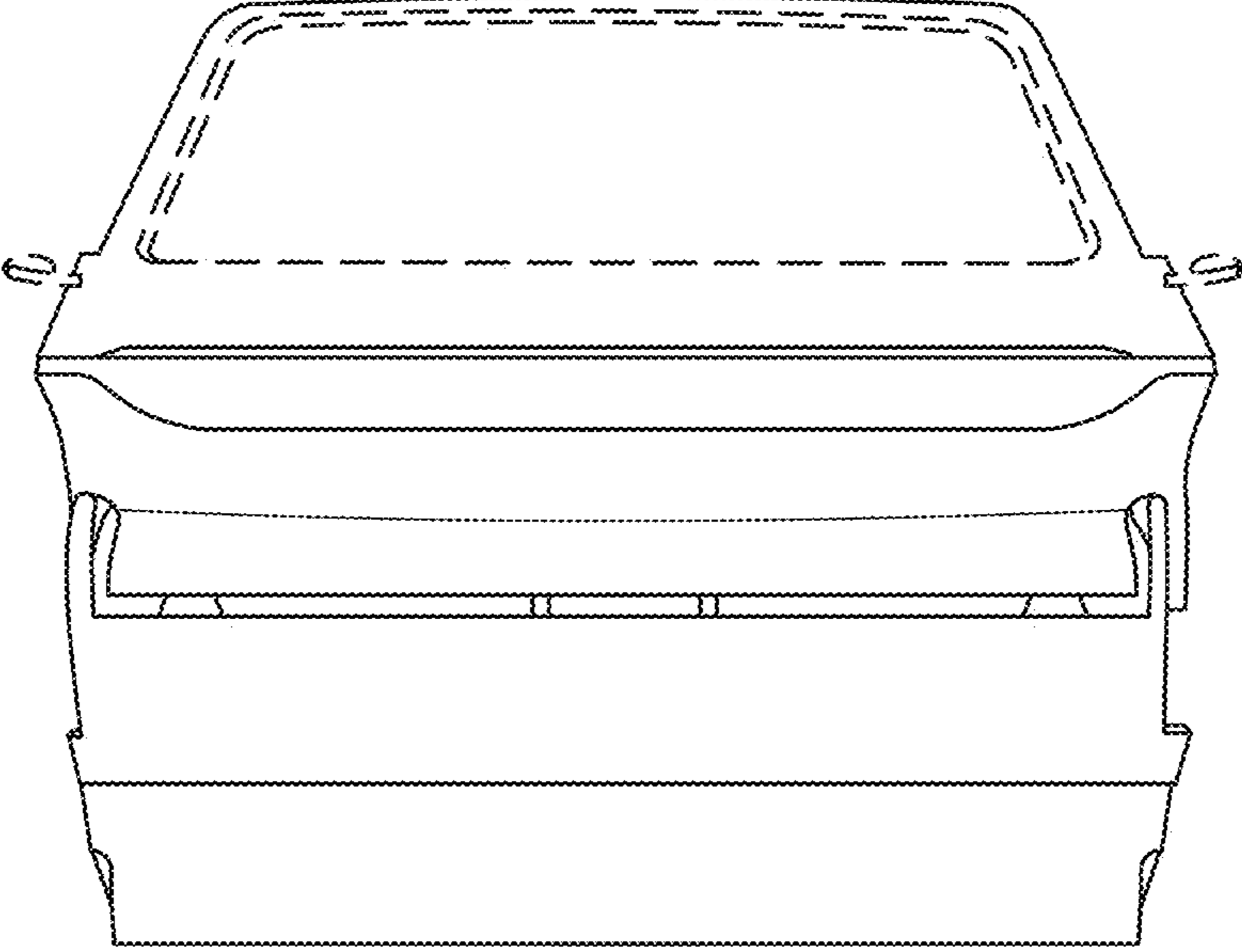

FIG. 1

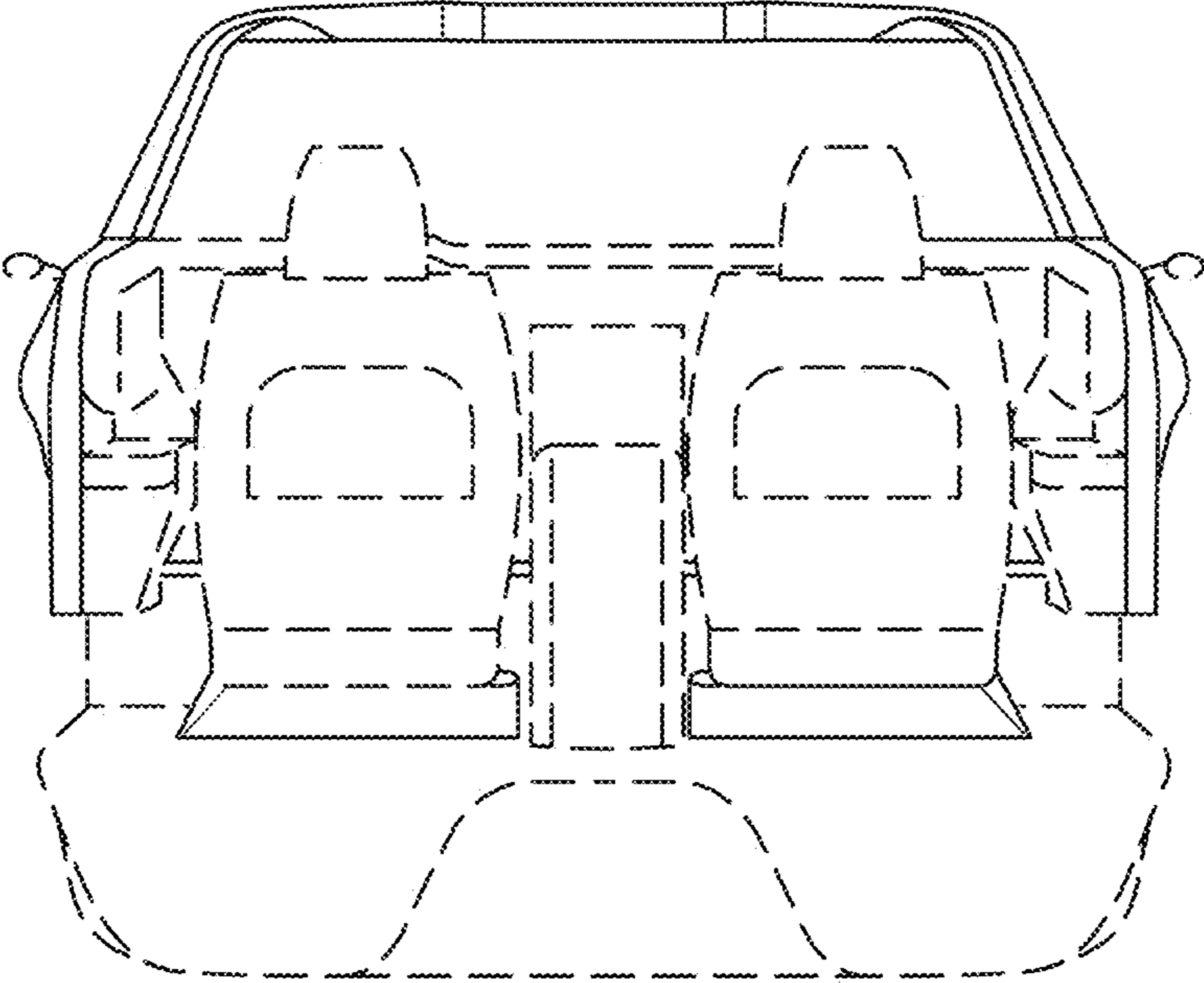

FIG. 2

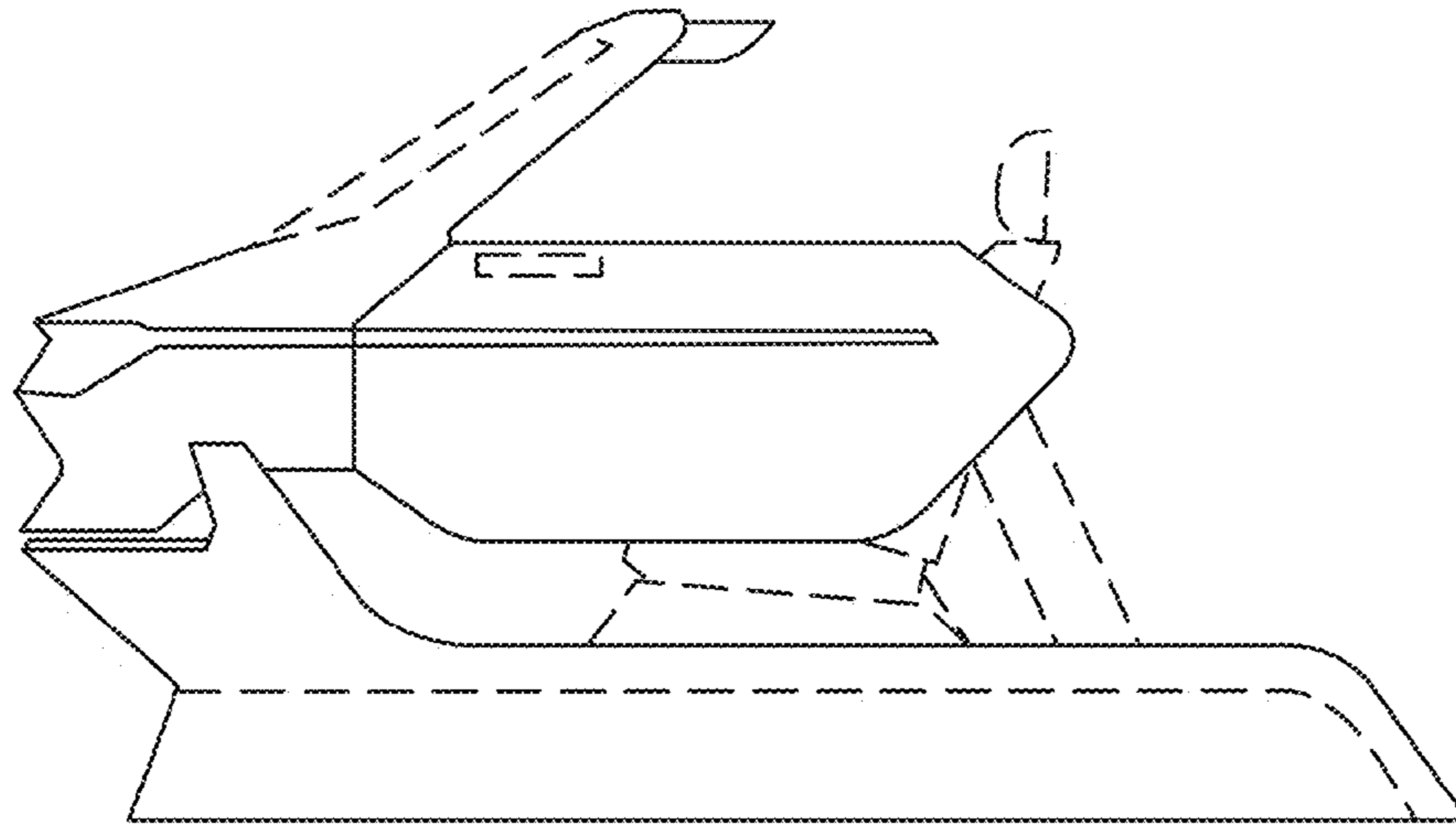

FIG. 3

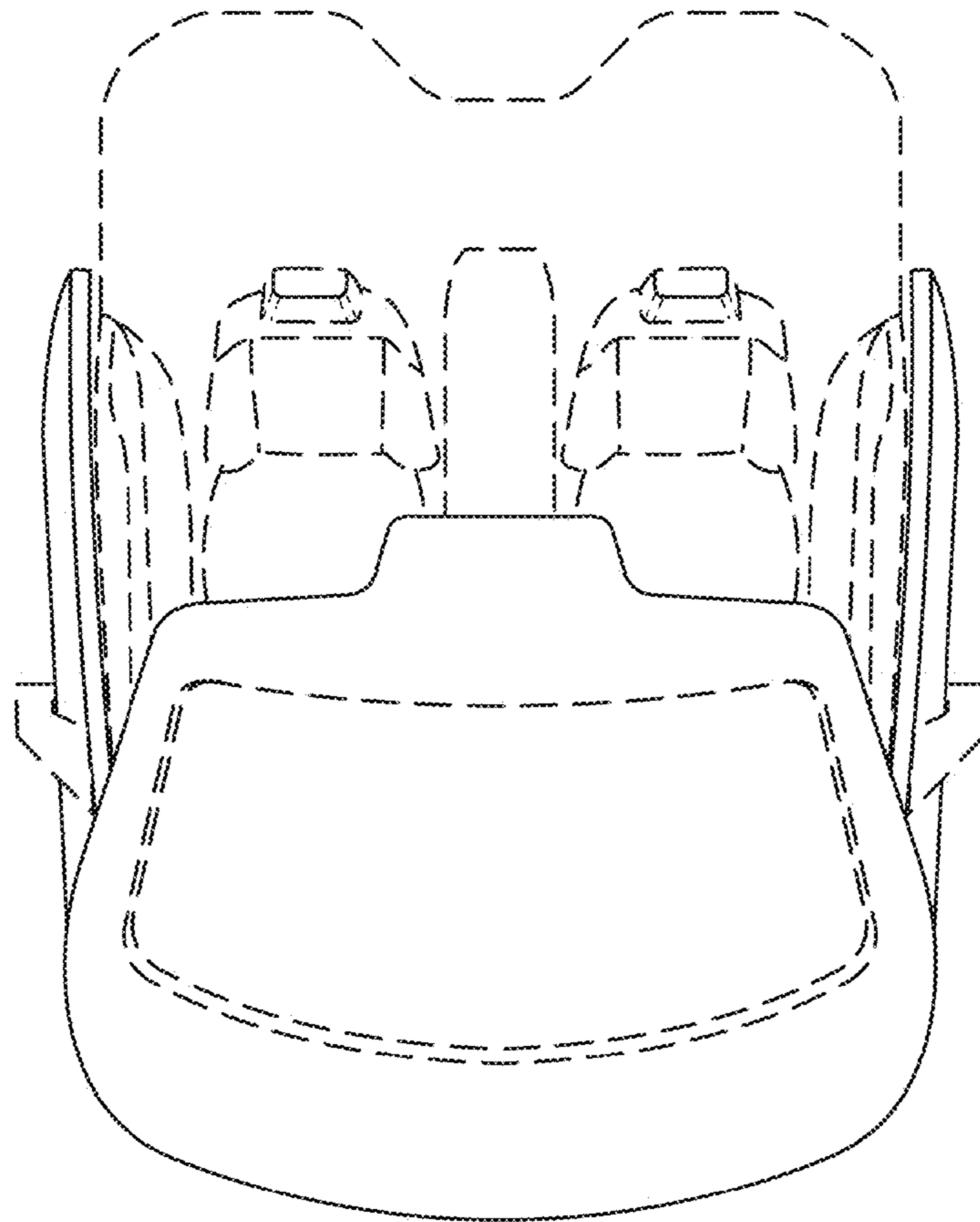

FIG. 4

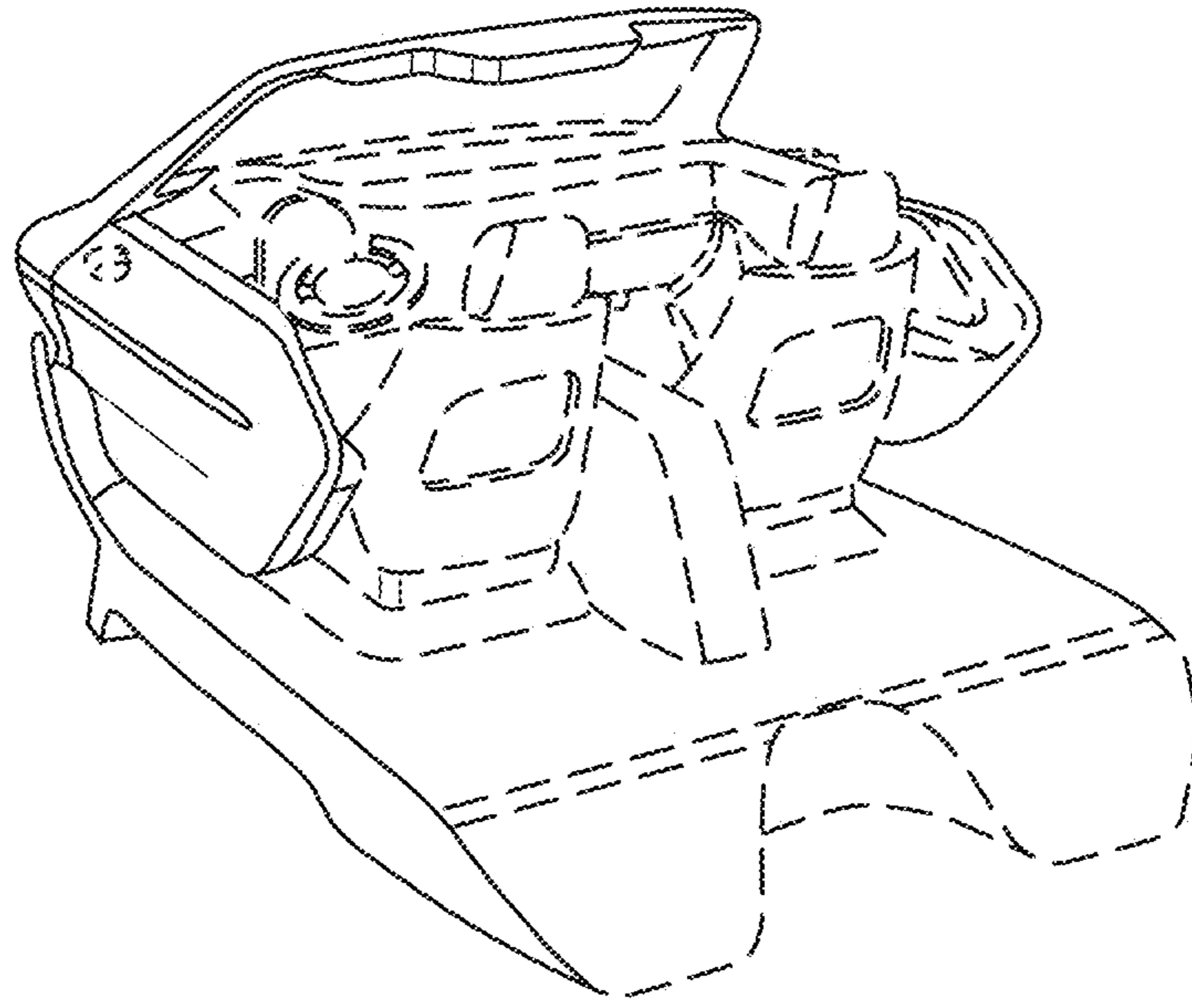

FIG. 5

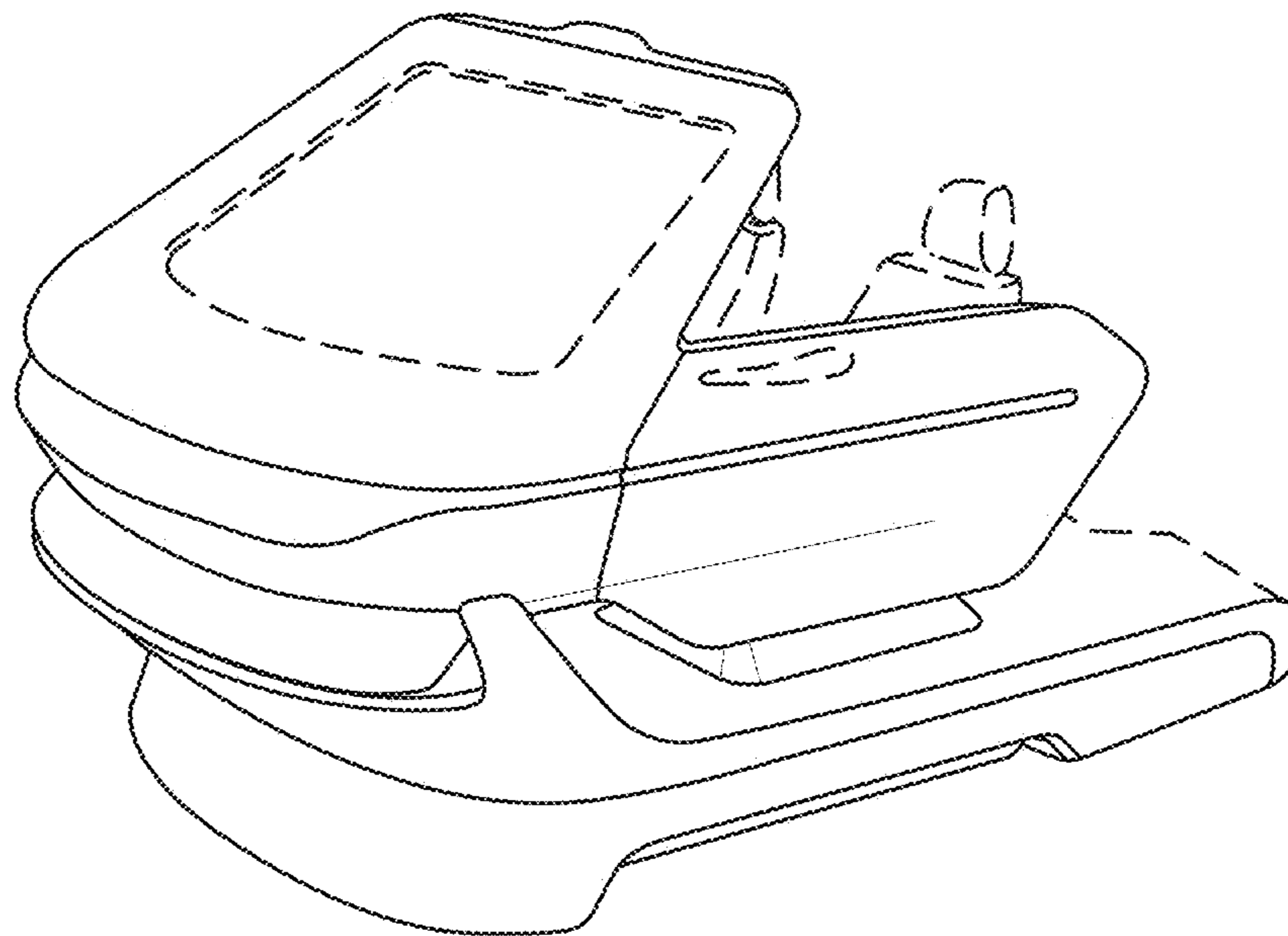

FIG. 6