



US00D901365S

(12) **United States Design Patent**  
**Urion**

(10) **Patent No.:** **US D901,365 S**  
(45) **Date of Patent:** **\*\* Nov. 10, 2020**

(54) **WATERCRAFT HULL**

- (71) Applicant: **Benjamin Stephen Urion**, Crystal Beach, FL (US)
- (72) Inventor: **Benjamin Stephen Urion**, Crystal Beach, FL (US)
- (\*\*) Term: **15 Years**
- (21) Appl. No.: **29/687,244**
- (22) Filed: **Apr. 11, 2019**

**Related U.S. Application Data**

- (62) Division of application No. 29/567,868, filed on Jun. 13, 2016, now Pat. No. Des. 852,719.
- (51) **LOC (12) Cl.** ..... **12-06**
- (52) **U.S. Cl.**  
USPC ..... **D12/314**
- (58) **Field of Classification Search**  
USPC ..... D12/300, 302–306, 308, 310, 313–314, D12/316–318, 190, 194, 400; D21/506–507, 533, 542–545; D23/259, D23/266; D25/119–123, 128  
CPC .. B63B 1/121; B63B 1/12; B63B 1/20; B63B 1/042; B63B 1/14; B63B 1/24; B63B 1/125; B63B 1/04; B63B 7/04; B63B 35/731; B63B 35/73; B63B 35/71; B63B 35/00; B63B 39/06; B63B 15/0083; B63G 8/001; B63G 8/08; B63G 8/00; B63G 2008/004;

(Continued)

(56) **References Cited**

**U.S. PATENT DOCUMENTS**

- 3,438,073 A \* 4/1969 Brown ..... B63B 19/02 114/361
- 3,959,837 A \* 6/1976 Archibald ..... B63B 23/62 114/343

(Continued)

**FOREIGN PATENT DOCUMENTS**

FR 3074136 A1 \* 5/2019

**OTHER PUBLICATIONS**

A Better Way to Boat, announced © 2020 [online], retrieved Apr. 22, 2020, retrieved from internet, <https://worldcat.com/advantages/a-better-way-to-boat/>.\*

(Continued)

*Primary Examiner* — Dana K Weiland  
*Assistant Examiner* — Messina L Smith  
(74) *Attorney, Agent, or Firm* — Smith & Hopen, P.A.; Paul Murty

(57) **CLAIM**

The ornamental design for a watercraft hull, as shown and described.

**DESCRIPTION**

FIG. 1 is a front perspective view of a watercraft hull, showing the novel design.  
 FIG. 2 is a rear perspective view of the watercraft hull shown in FIG. 1.  
 FIG. 3 is a top plan view of the watercraft hull shown in FIG. 1.  
 FIG. 4 is a bottom plan view of the watercraft hull shown in FIG. 1.  
 FIG. 5 is a left side elevation view of the watercraft hull shown in FIG. 1.  
 FIG. 6 is right side elevation view of the watercraft shown in FIG. 1.  
 FIG. 7 is front elevation view of the watercraft hull shown in FIG. 1; and,  
 FIG. 8 is rear elevation view of the watercraft hull shown in FIG. 1.  
 The broken lines showing the steering wheel and tower depict environment and form no part of the claimed design. All other broken lines depict portions of the watercraft hull that form no part of the claimed design.

**1 Claim, 8 Drawing Sheets**

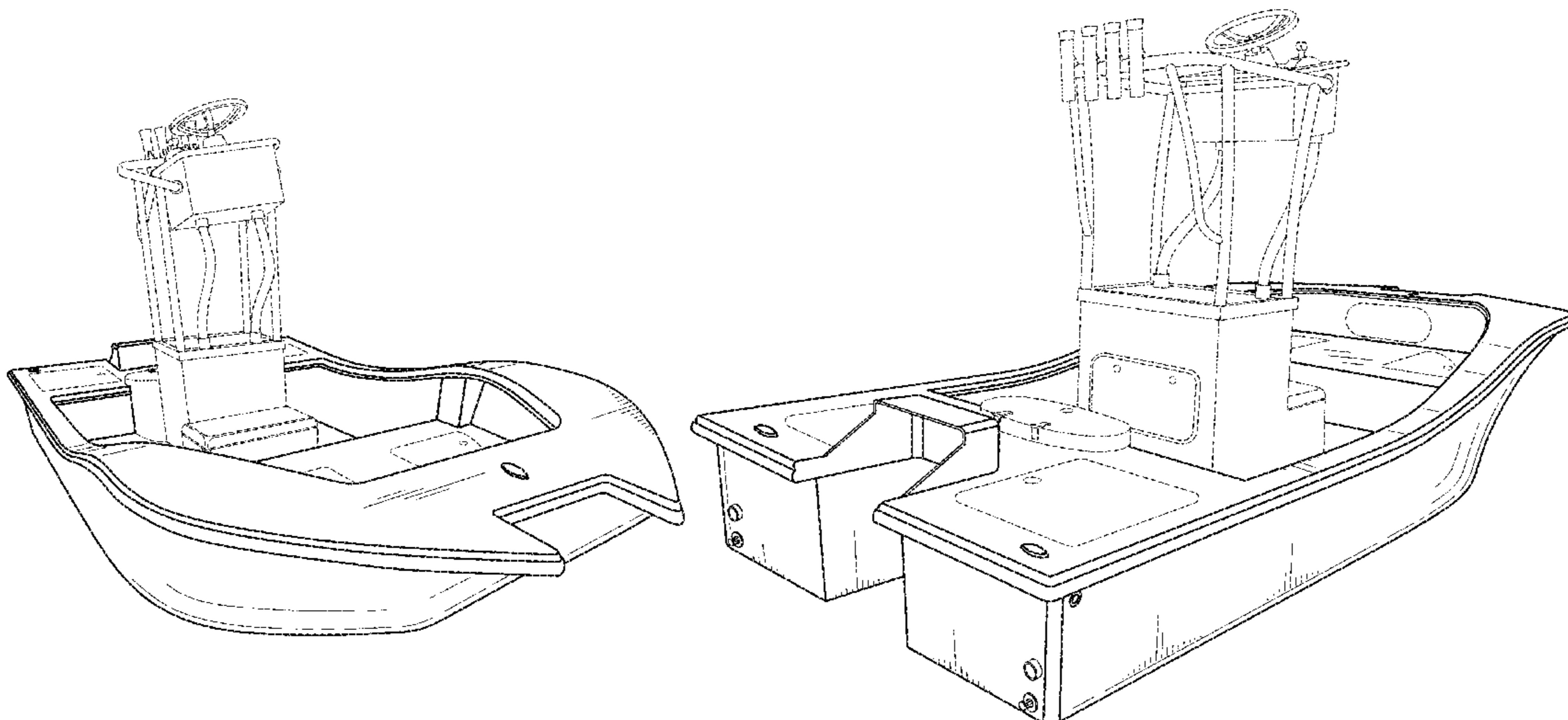

(58) **Field of Classification Search**  
 CPC ..... B63G 2008/005; B63G 2008/002; B21D  
 22/025  
 See application file for complete search history.

(56) **References Cited**

U.S. PATENT DOCUMENTS

D387,324	S	*	12/1997	Beulac	.....	D12/300
D390,184	S	*	2/1998	Van Skyhawk	.....	D12/300
D395,636	S	*	6/1998	Pierce	.....	D12/300
D397,081	S	*	8/1998	Arvilla	.....	D12/315
D402,618	S	*	12/1998	Veazey	.....	D12/310
7,107,927	B2	*	9/2006	Hopper	.....	B63B 3/48 114/363
7,487,736	B2	*	2/2009	Daley	.....	B63B 1/042 114/271
7,963,240	B1	*	6/2011	Werner	.....	B63B 1/121 114/288
D662,028	S	*	6/2012	Finbow	.....	D12/317
D686,969	S	*	7/2013	Finbow	.....	D12/318
D715,726	S	*	10/2014	Curts	.....	D12/317
D840,909	S	*	2/2019	Mattila	.....	D12/300

10,272,970	B2	*	4/2019	Watts	.....	B63B 1/121
D848,347	S	*	5/2019	Mattila	.....	D12/300
D850,355	S	*	6/2019	Lammerts	.....	D12/316
D852,719	S	*	7/2019	Urion	.....	D12/314
10,370,068	B2	*	8/2019	Dieters	.....	E02B 15/10
D868,666	S	*	12/2019	Zolotuhin	.....	D12/300
D872,002	S	*	1/2020	Kobylko	.....	D12/300
10,549,834	B2	*	2/2020	Ito	.....	B63H 21/21
D877,683	S	*	3/2020	Shirokikh	.....	D12/300
2006/0189249	A1	*	8/2006	Wong	.....	A63H 30/04 446/165
2006/0260527	A1	*	11/2006	Ackerbloom	.....	B63B 1/20 114/288
2019/0263475	A1	*	8/2019	Cooper	.....	B63B 7/082
2020/0047864	A1	*	2/2020	Myer	.....	B63H 16/18

OTHER PUBLICATIONS

Carolina Cat 23CC, announced Oct. 20, 2012 [online], retrieved Apr. 22, 2020, retrieved from internet, <https://www.boats.com/reviews/carolina-cat-23cc-twin-hulls-do-double-duty/>.\*

\* cited by examiner

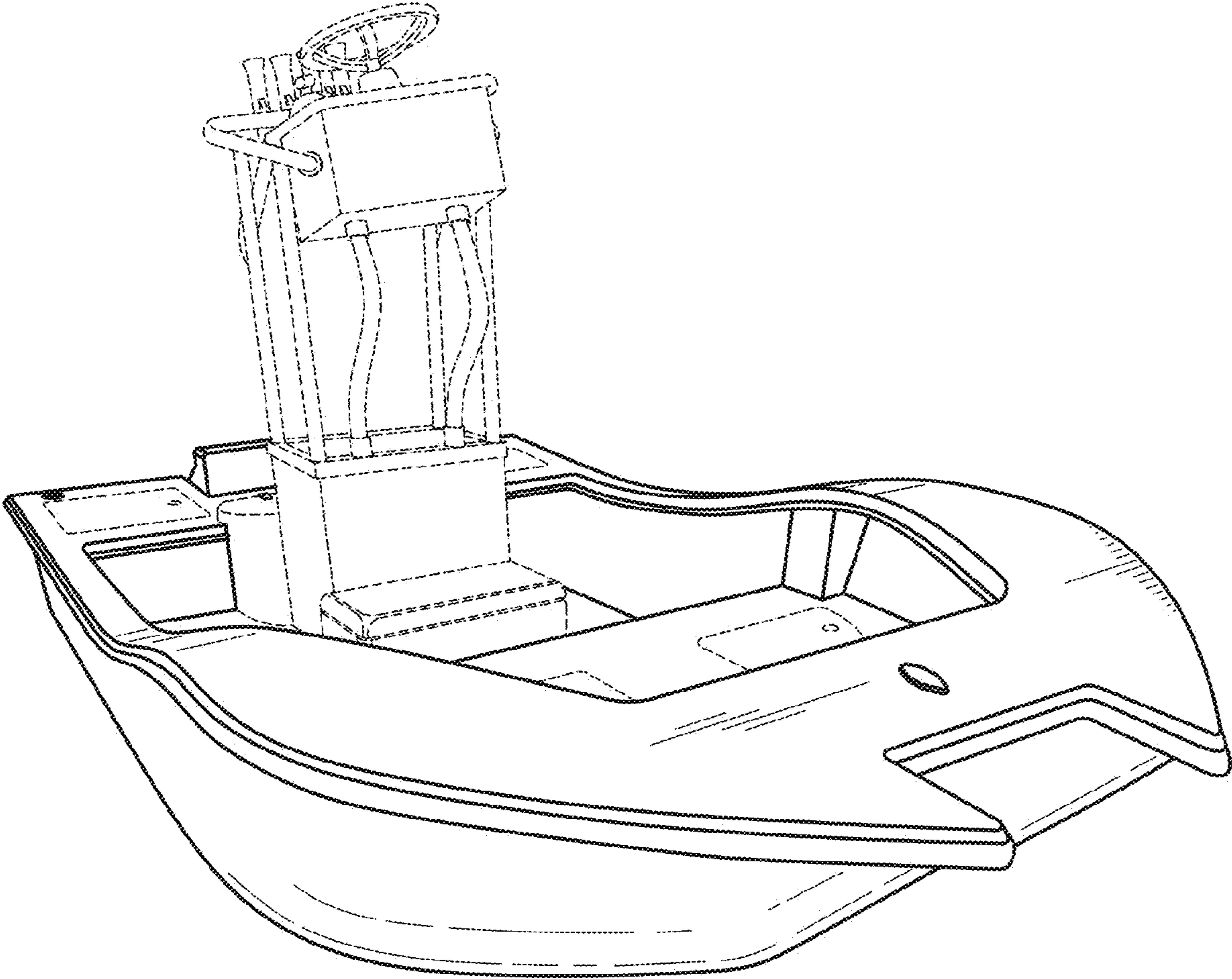
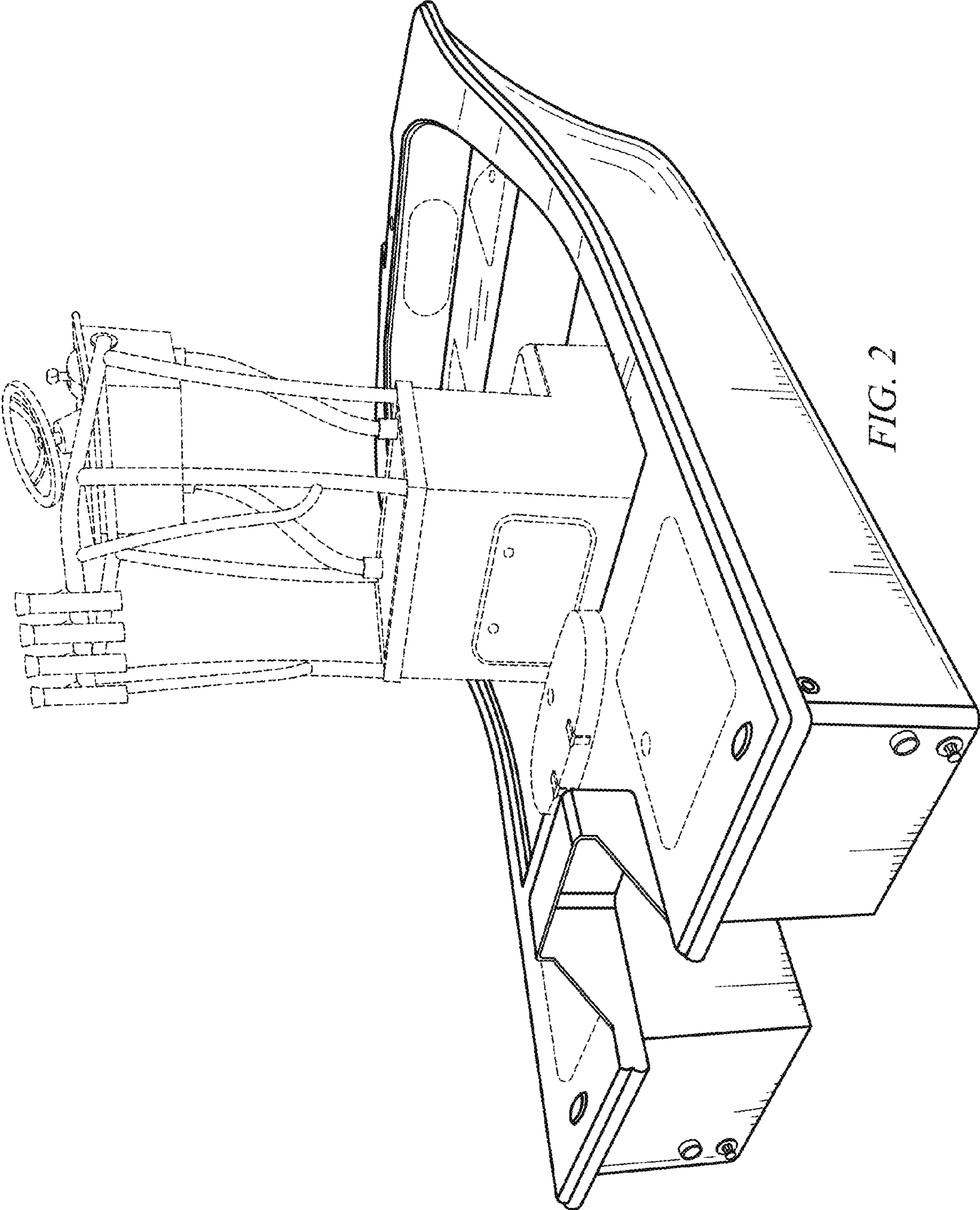

FIG. 1



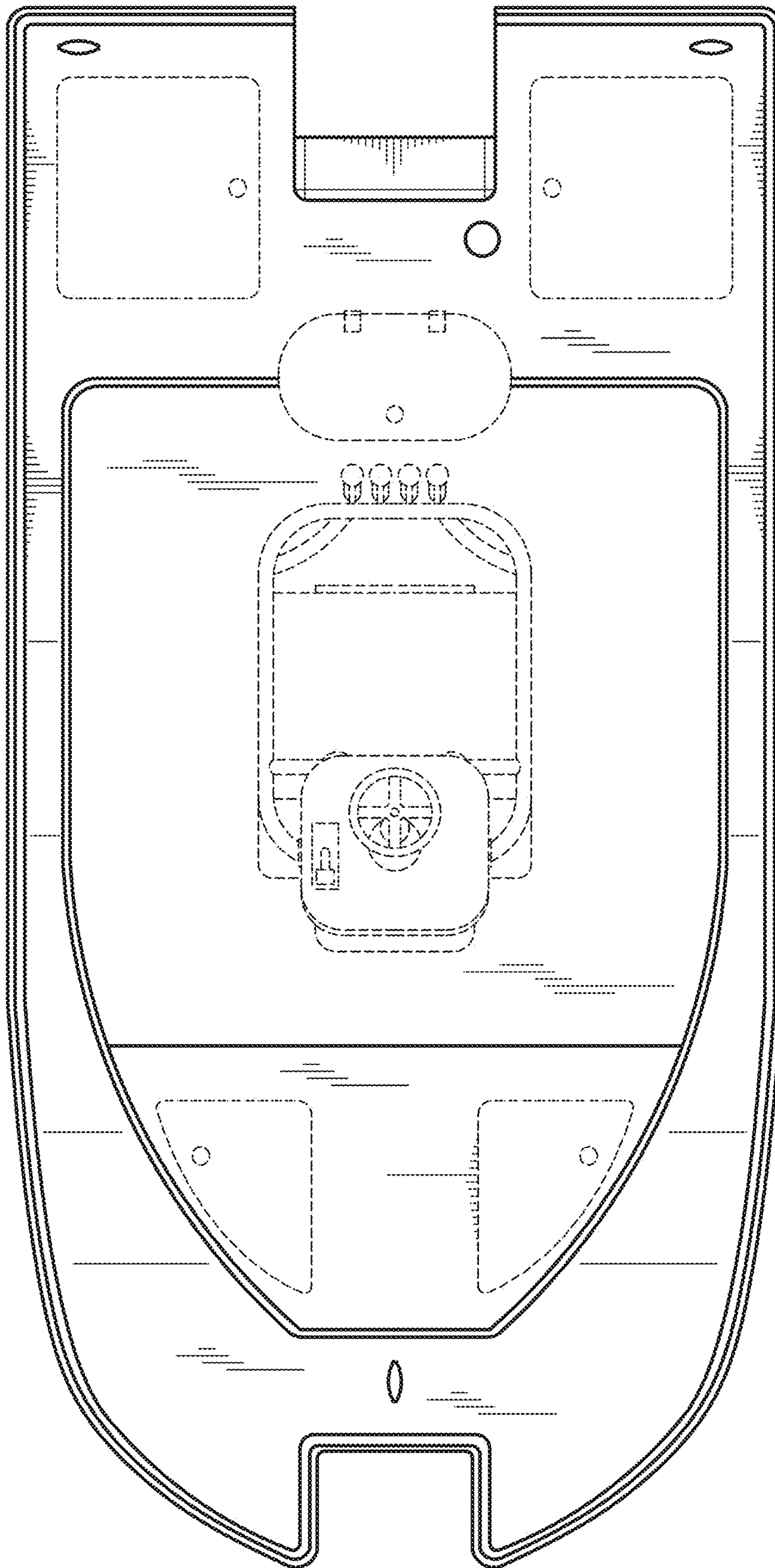

FIG. 3

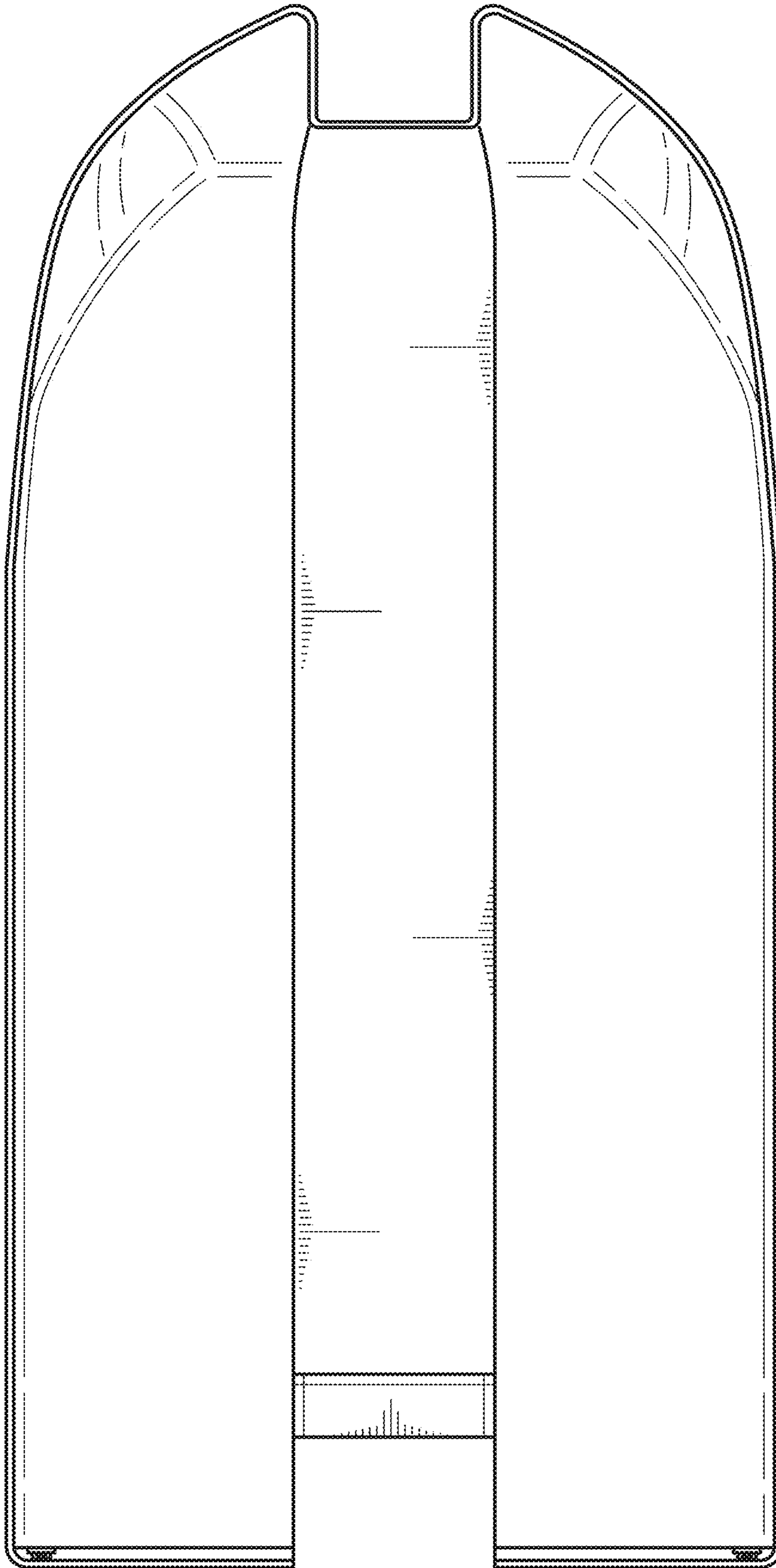

FIG. 4

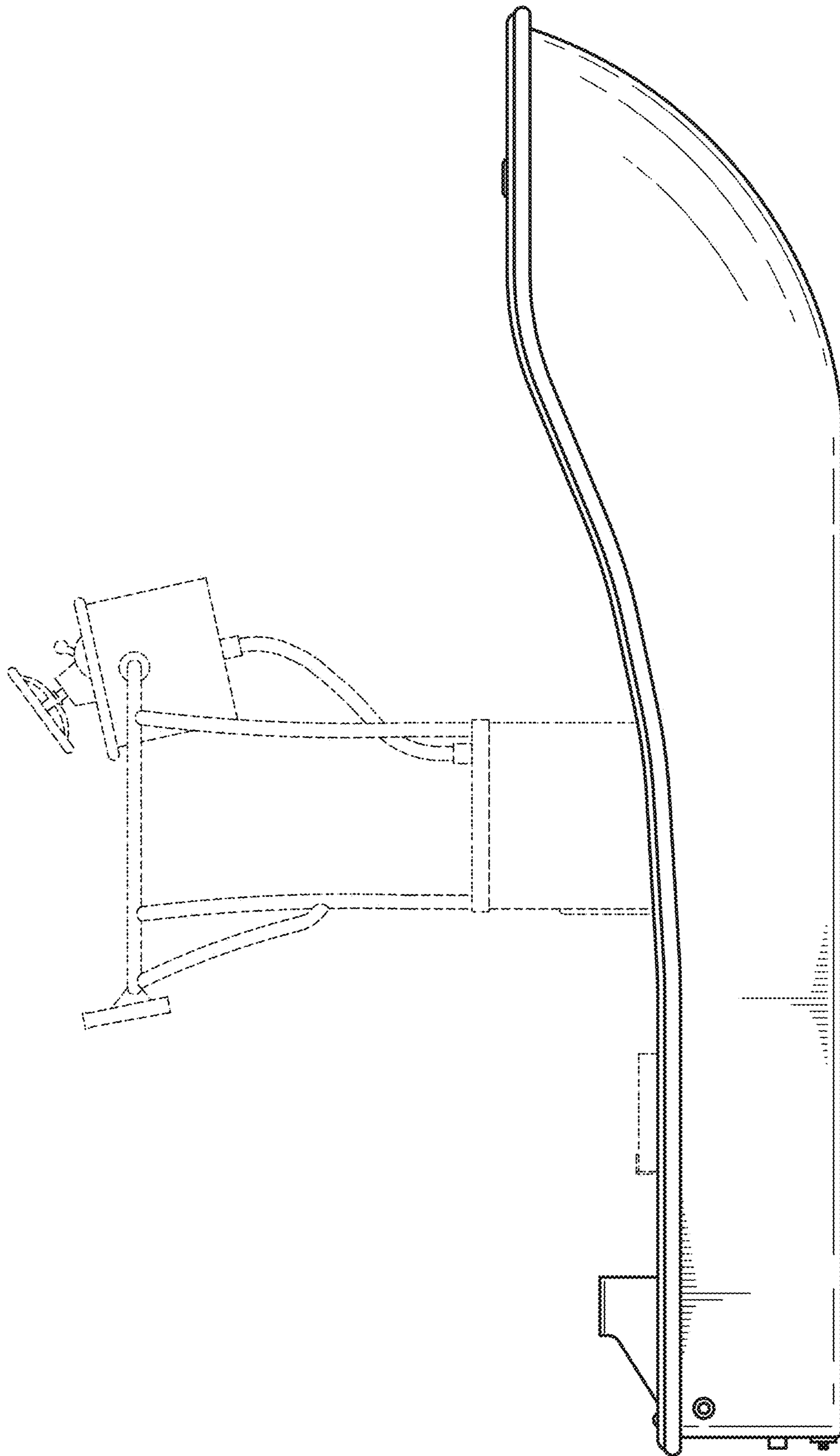

FIG. 5

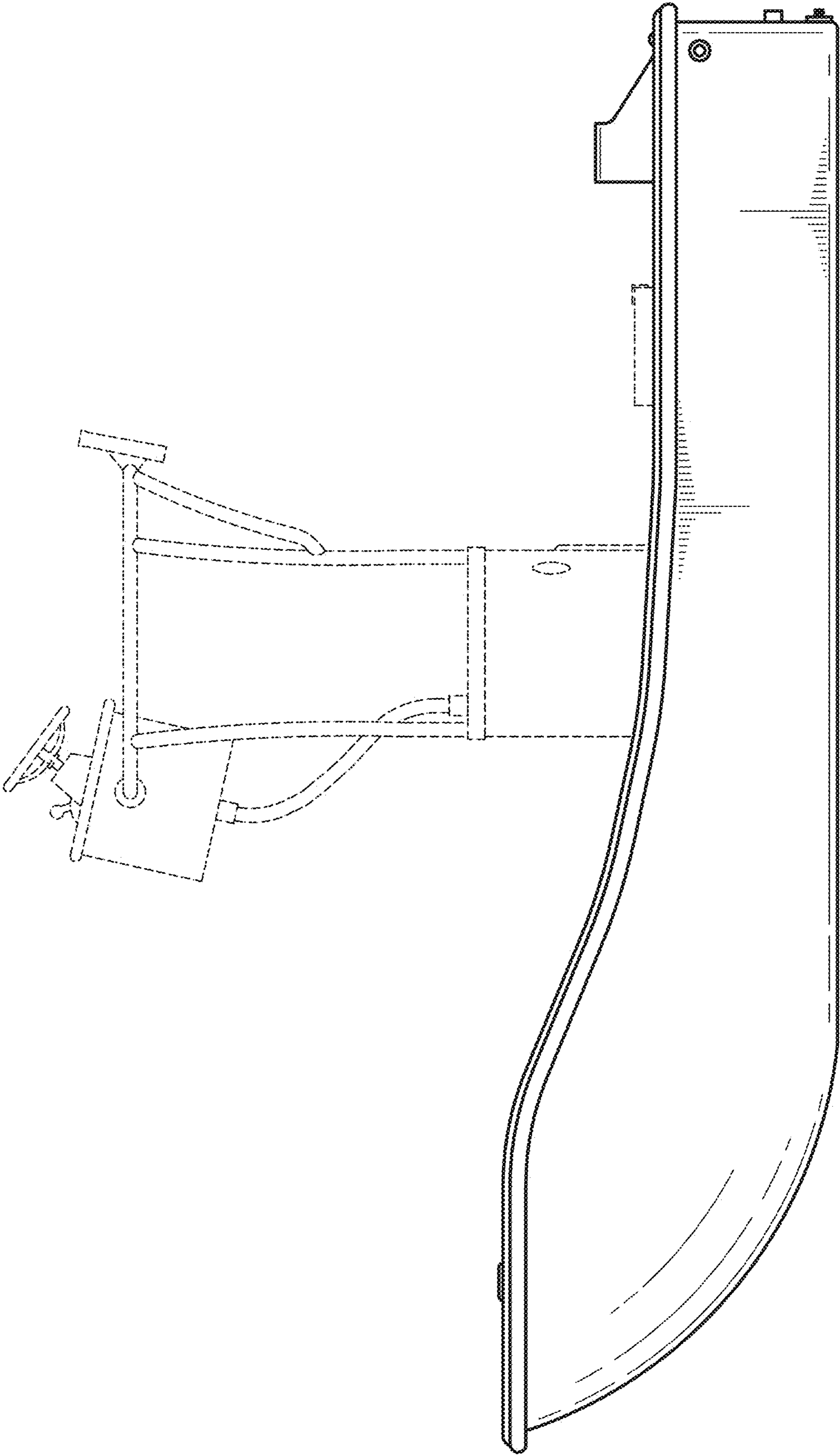

FIG. 6



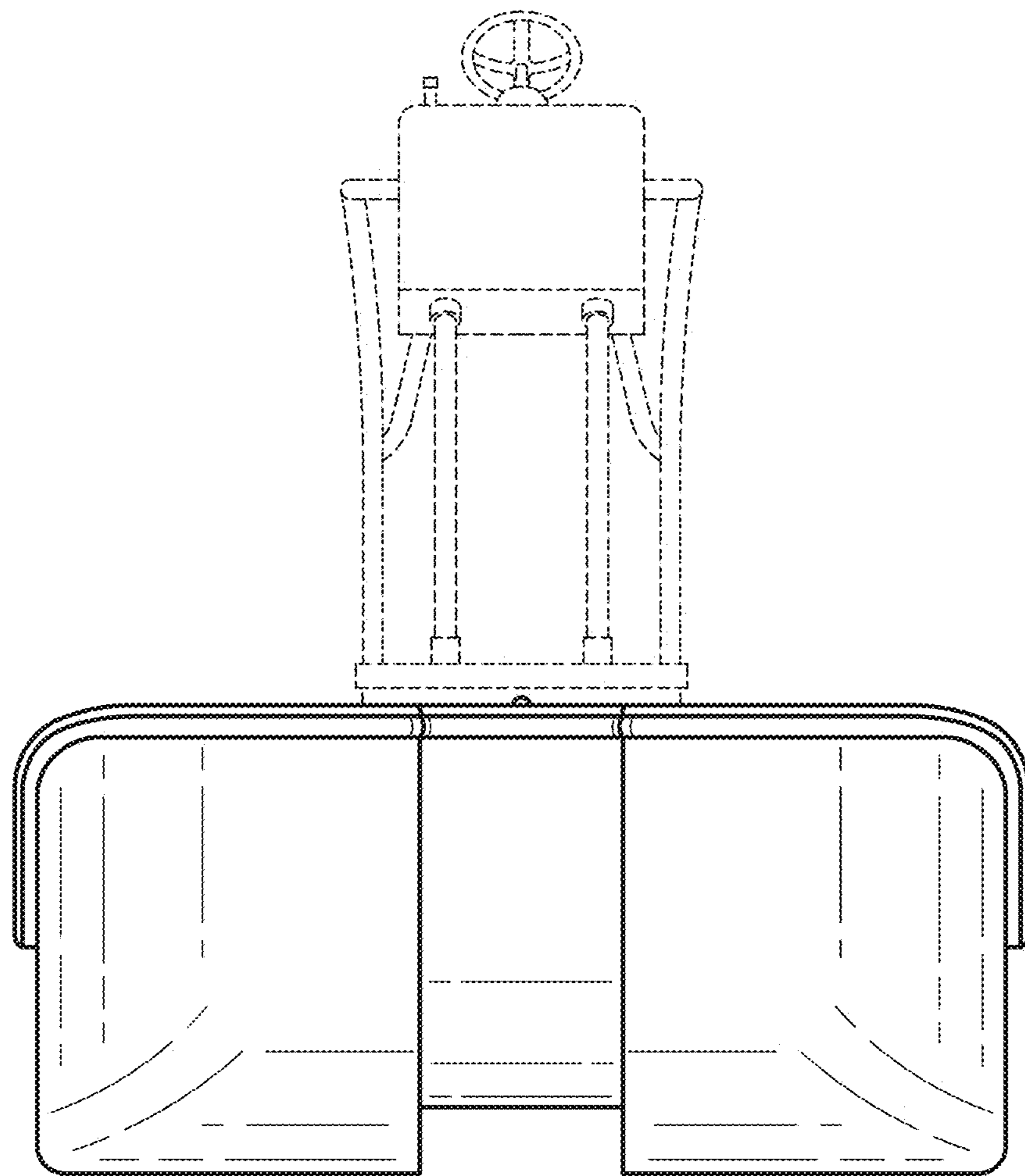

FIG. 7

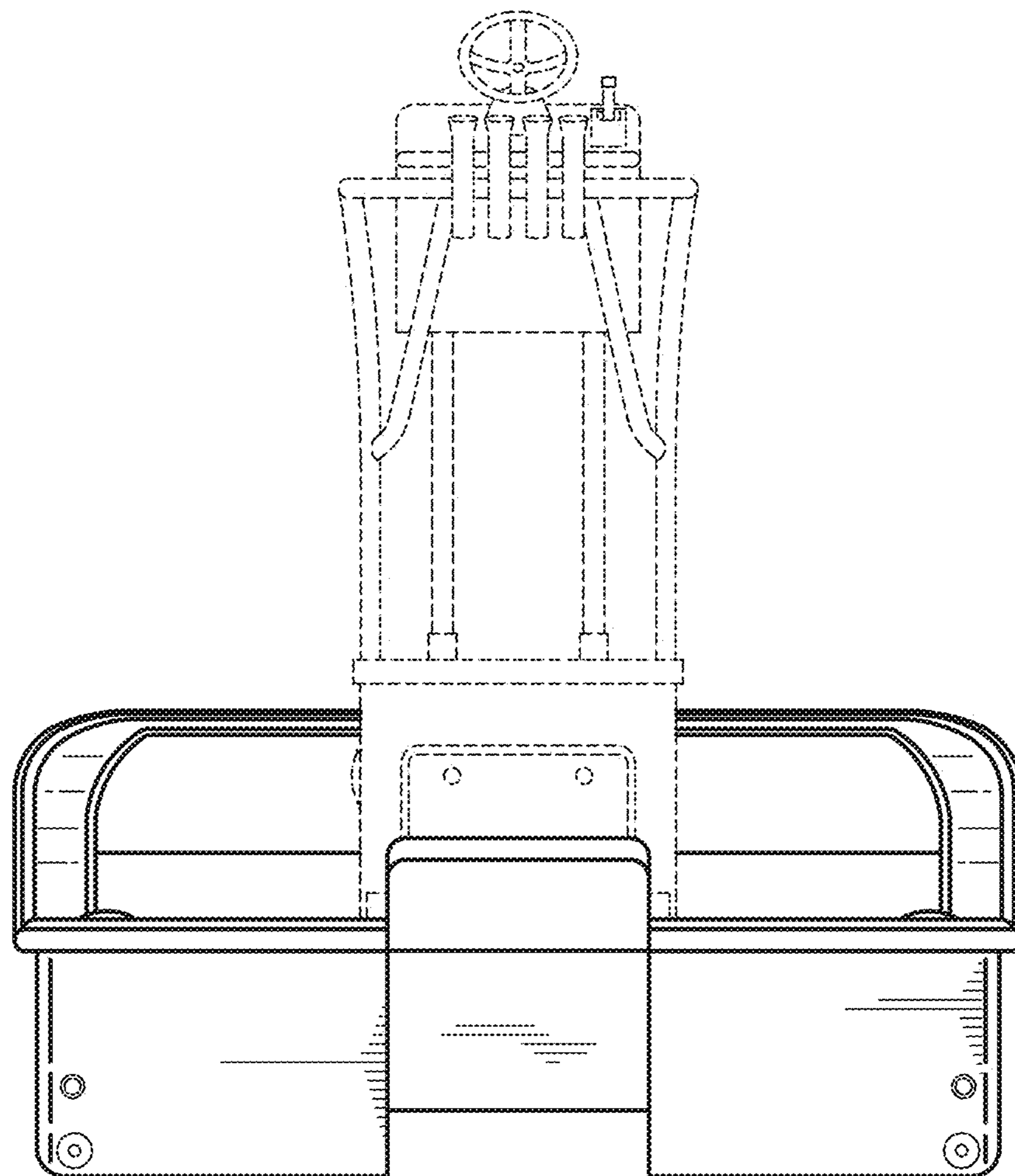

FIG. 8