



US00D901356S

(12) **United States Design Patent**
Ninov et al.

(10) **Patent No.:** **US D901,356 S**

(45) **Date of Patent:** **** Nov. 10, 2020**

(54) **AUTOMOBILE WHEEL**

(71) Applicants: **Deyan Ninov**, Royal Oak, MI (US);
Timothy A. Doyle, Rochester, MI (US)

(72) Inventors: **Deyan Ninov**, Royal Oak, MI (US);
Timothy A. Doyle, Rochester, MI (US)

(73) Assignee: **FCA US LLC**, Auburn Hills, MI (US)

(**) Term: **15 Years**

(21) Appl. No.: **29/694,084**

(22) Filed: **Jun. 7, 2019**

(51) **LOC (12) Cl.** **12-16**

(52) **U.S. Cl.**
USPC **D12/209**; D21/563

(58) **Field of Classification Search**
USPC D12/204–213; D21/563
CPC B60B 7/00; B60B 7/02; B60B 7/04; B60B
7/01; B60B 7/06; B60B 3/02; B60B 3/04;
B60B 3/06; B60B 3/10; B60B 1/00;
B60B 1/08; B60B 1/10; B60B 1/12
See application file for complete search history.

(56) **References Cited**

U.S. PATENT DOCUMENTS

D748,033 S *	1/2016	Carter	D12/211
D758,943 S *	6/2016	Elmitt	D12/209
D769,166 S *	10/2016	Juergens	D12/211
D780,664 S *	3/2017	Gallert	D12/211
D787,409 S *	5/2017	Smith	D12/211

D788,005 S *	5/2017	Peat	D12/211
D808,324 S *	1/2018	Ninov	D12/211
D823,769 S *	7/2018	Gallert	D12/209
D825,422 S *	8/2018	Bjerke	D12/209
D826,824 S *	8/2018	Platto	D12/209
D835,559 S *	12/2018	Langhals	D12/209
D845,858 S *	4/2019	Chu	D12/209
D847,072 S *	4/2019	Badstuebner	D12/209
D849,645 S *	5/2019	Khachatryan	D12/209
D851,006 S *	6/2019	Hans	D12/209
D851,009 S *	6/2019	Waldron	D12/209
D851,010 S *	6/2019	Sze	D12/209
D854,481 S *	7/2019	Bucher	D12/209
D860,906 S *	9/2019	Valencia Pollex	D12/209
D883,888 S *	5/2020	Daniel	D12/209
D885,288 S *	5/2020	Preyss	D12/209

* cited by examiner

Primary Examiner — Stacia A Cadmus

(74) *Attorney, Agent, or Firm* — Ralph E. Smith

(57) **CLAIM**

The ornamental design for an automobile wheel, as shown and described.

DESCRIPTION

FIG. 1 is a front view of an automobile wheel showing our new design;
FIG. 2 is a left perspective view thereof; and,
FIG. 3 is a right perspective view thereof.
It will be understood that the broken lines shown in the drawings illustrate portions of the automobile wheel that form no part of the claimed design.

1 Claim, 3 Drawing Sheets

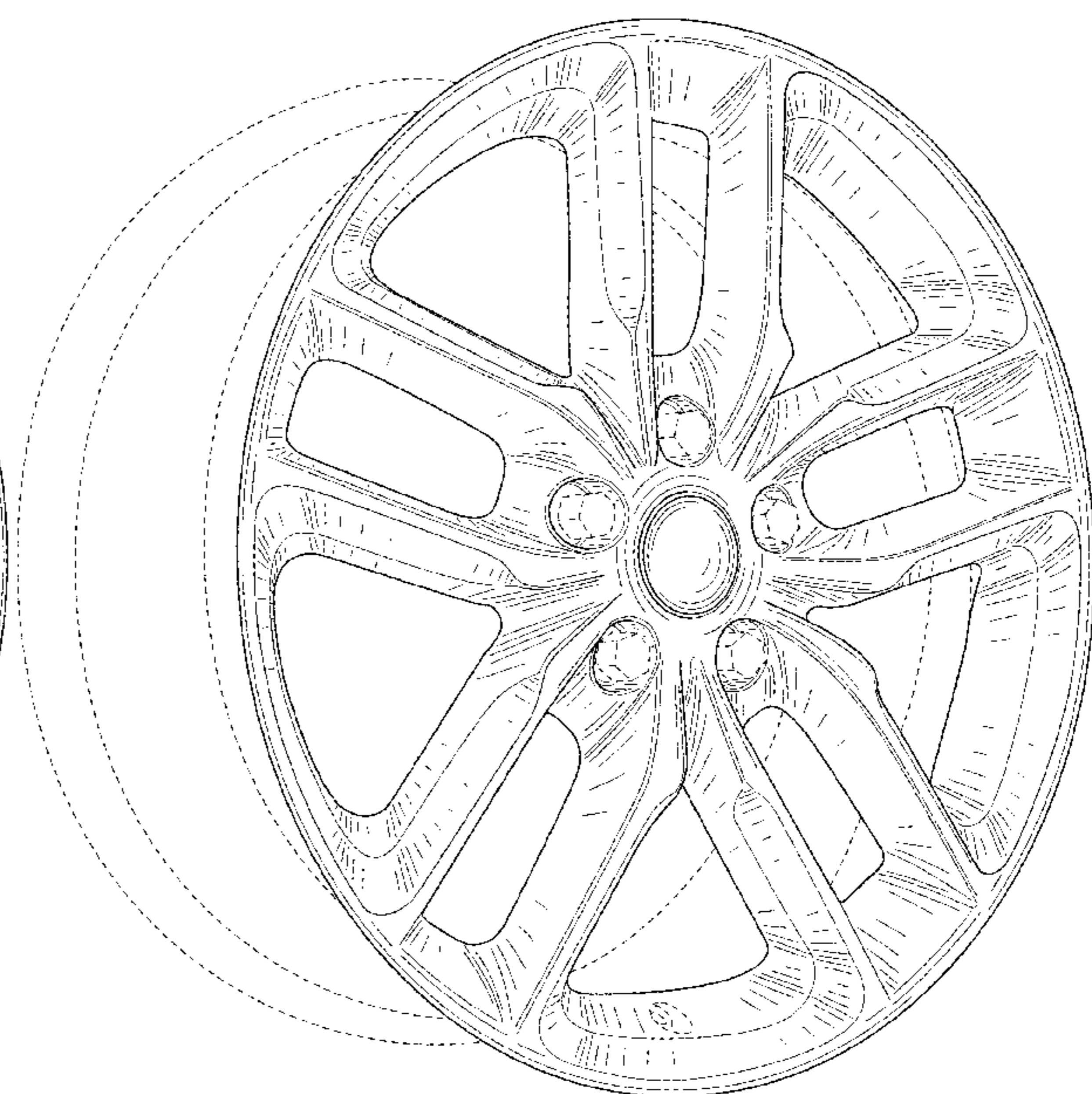
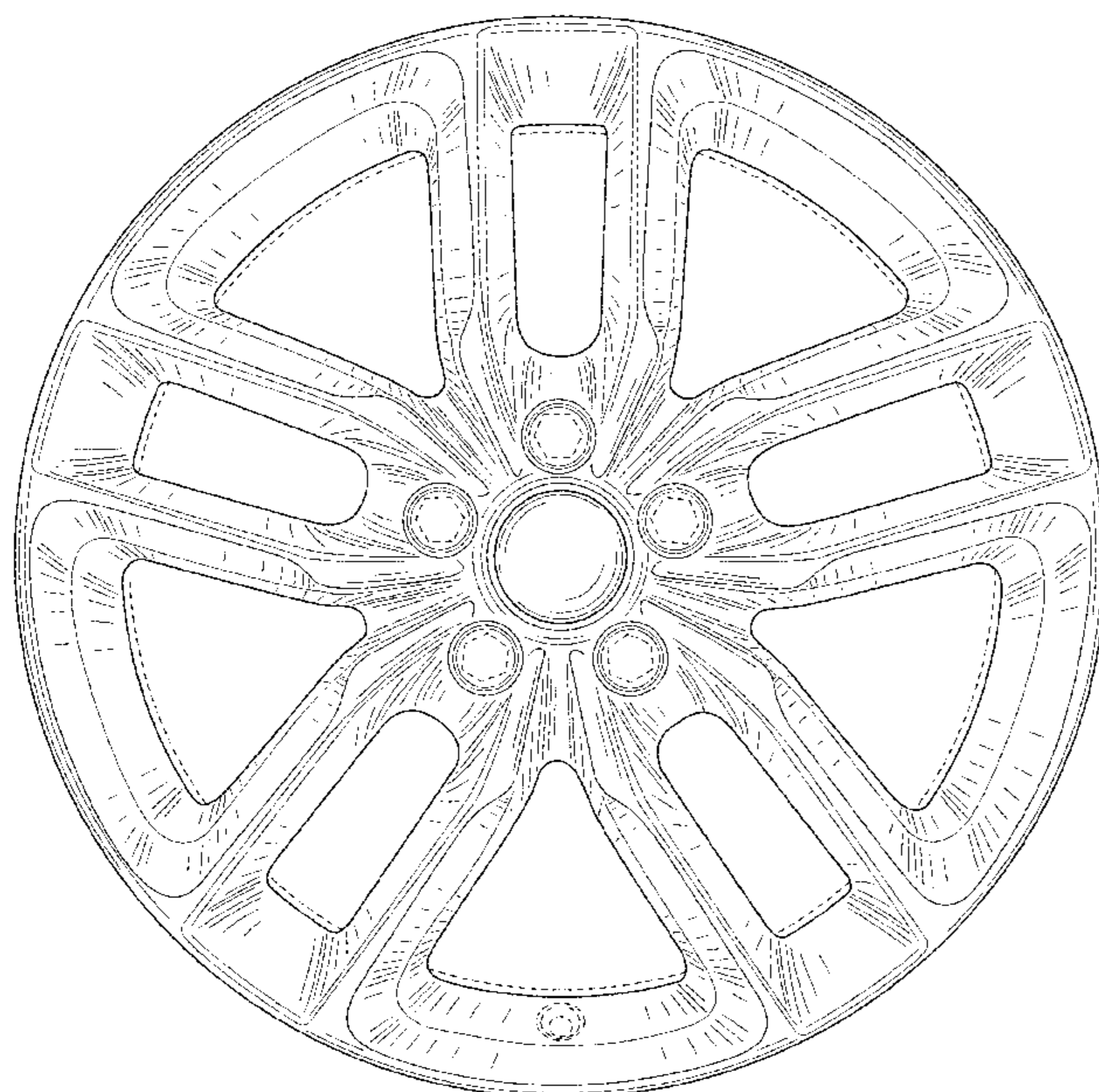

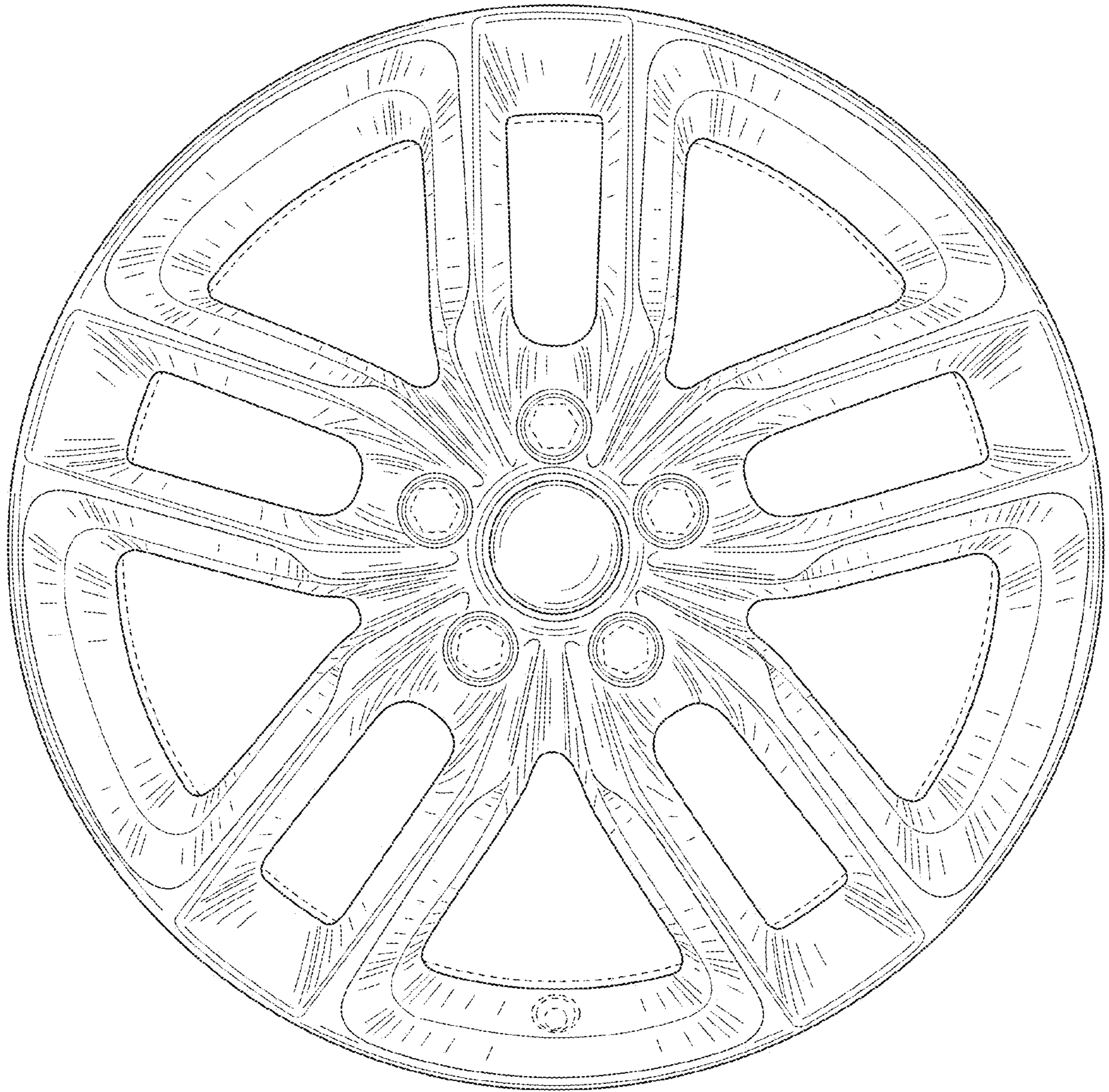

FIG. 1

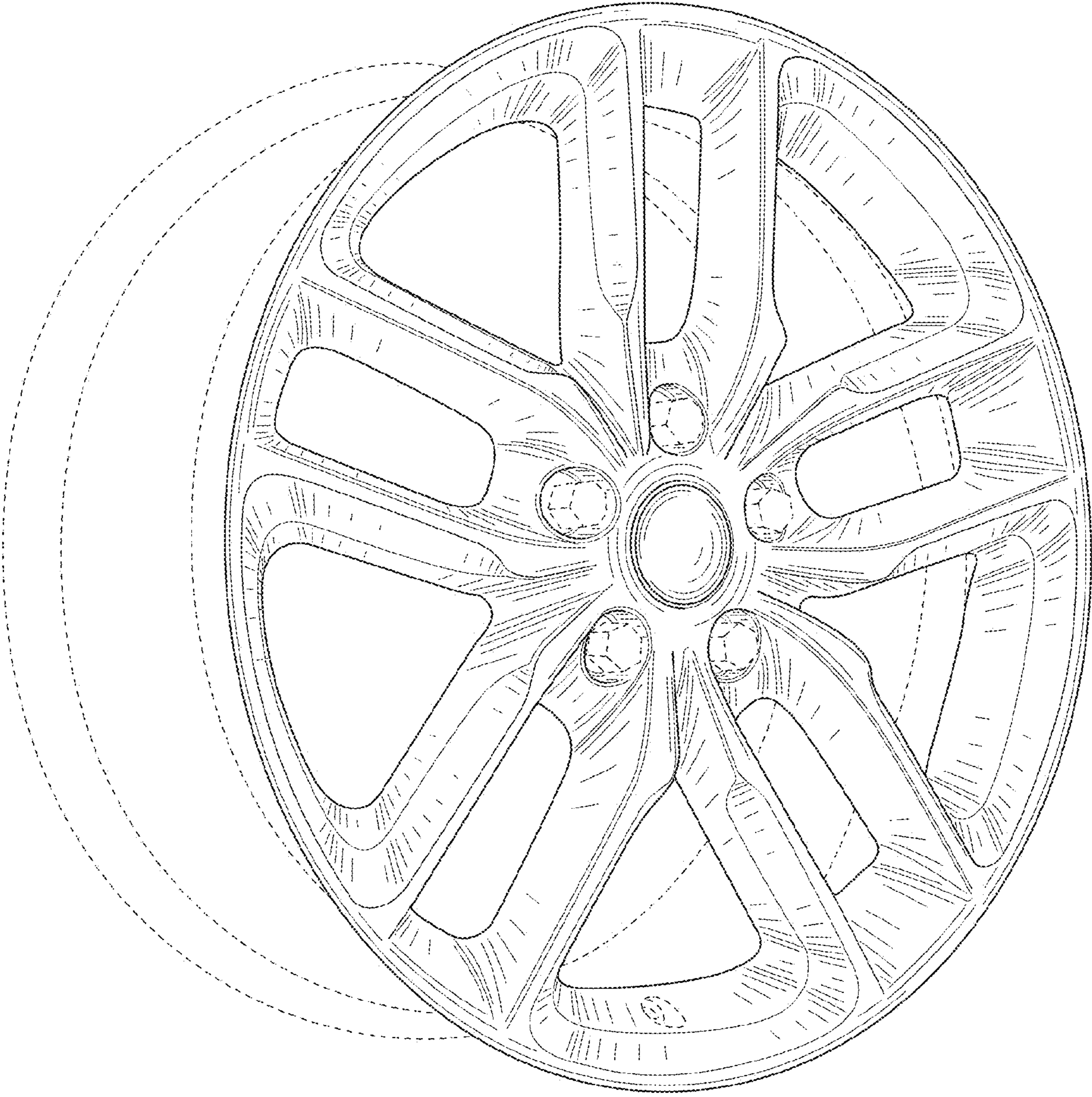

FIG. 2

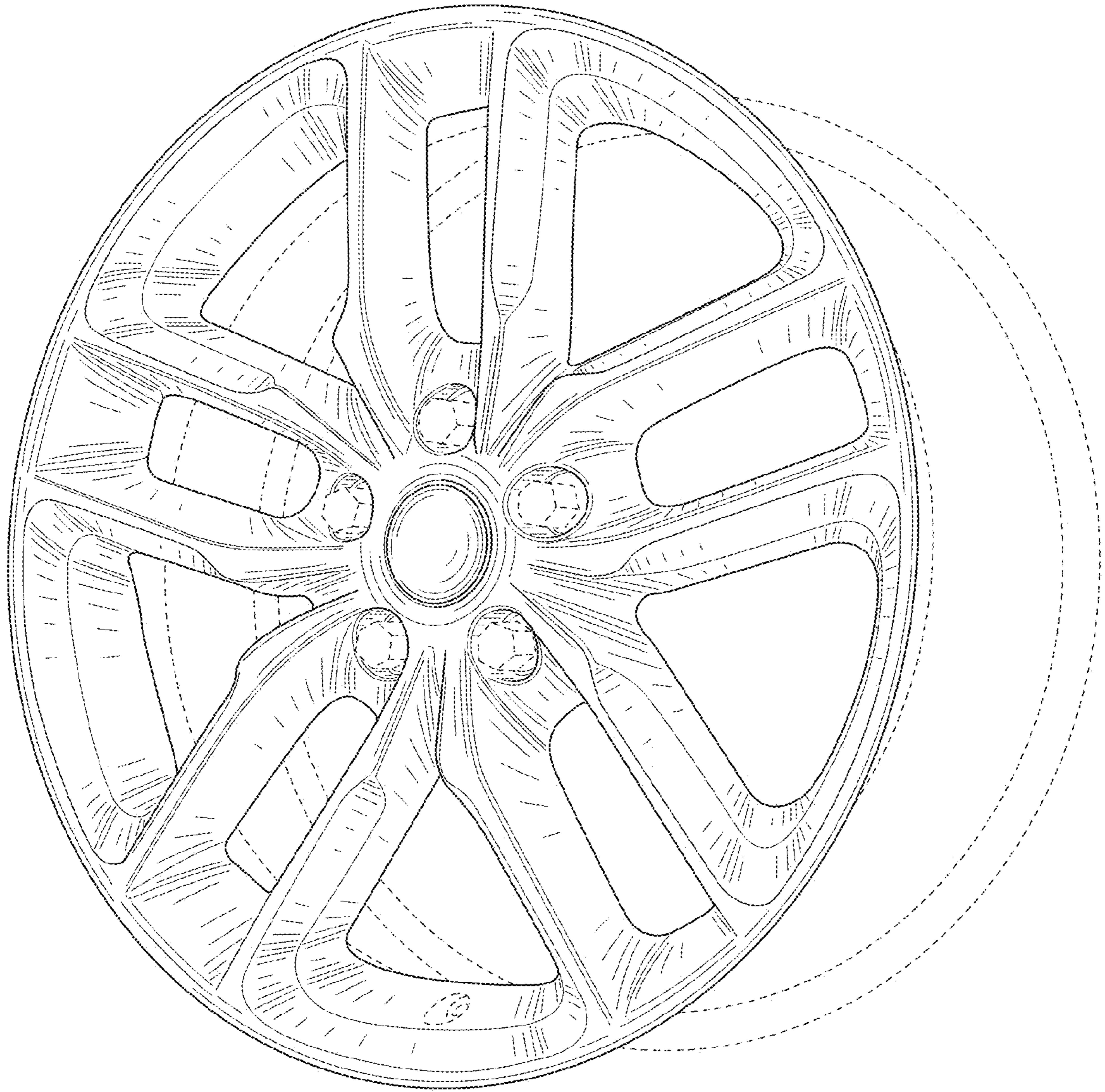

FIG. 3