



US00D901347S

(12) **United States Design Patent** (10) **Patent No.:** **US D901,347 S**  
**Schellekens et al.** (45) **Date of Patent:** **\*\* Nov. 10, 2020**

(54) **ROOF COMPONENT FOR A MOTOR VEHICLE**

FOREIGN PATENT DOCUMENTS

(71) Applicant: **SABIC Global Technologies B.V.**,  
Bergen op Zoom (NL)

CA 2020546 2/1991  
CN 1747858 A 3/2006  
(Continued)

(72) Inventors: **Geert Jan Schellekens**, Gilze (NL);  
**Carlos Pereira**, Putnam Valley, NY  
(US); **Bhushan Subhash Deshmukh**,  
Bangalore (IN); **Max Morton**,  
Pittsfield, MA (US)

OTHER PUBLICATIONS

Browand, F., "Reducing Aerodynamic Drag and Fuel Consumption", Global Climate and Energy Project, Advanced Transportation Workshop, (Oct. 2005), Stanford University, 27 pages.  
(Continued)

(73) Assignee: **SABIC GLOBAL TECHNOLOGIES B.V.**, Bergen op Zoom (NL)

*Primary Examiner* — Katrina A Betton  
(74) *Attorney, Agent, or Firm* — Cantor Colburn LLP

(\*\*) Term: **15 Years**

(57) **CLAIM**

(21) Appl. No.: **29/699,892**

The ornamental design for a roof component for a motor vehicle, as shown and described.

(22) Filed: **Jul. 30, 2019**

**DESCRIPTION**

**Related U.S. Application Data**

(62) Division of application No. 29/649,424, filed on May 30, 2018, now Pat. No. Des. 862,330, which is a  
(Continued)

(51) **LOC (12) Cl.** ..... **12-16**

(52) **U.S. Cl.**  
USPC ..... **D12/181**

(58) **Field of Classification Search**  
USPC ..... D12/181, 182, 183, 184, 191, 400  
(Continued)

(56) **References Cited**

U.S. PATENT DOCUMENTS

3,162,745 A 12/1964 Rohr  
3,633,934 A 1/1972 Wilfert  
(Continued)

FIG. 1 is a front perspective view of a roof component for a motor vehicle, showing our new design;  
FIG. 2 is a rear perspective view of FIG. 1;  
FIG. 3 is a front elevation view of FIG. 1;  
FIG. 4 is a rear elevation view of FIG. 1;  
FIG. 5 is a side elevation view of FIG. 1;  
FIG. 6 is another side elevation view of FIG. 1;  
FIG. 7 is a top plan view of FIG. 1;  
FIG. 8 is a bottom perspective view of FIG. 1; and,  
FIG. 9 is another perspective view of FIG. 1 as shown in a motor vehicle environment.  
The broken lines are for environmental purpose only and form no part of the claimed design.  
The dash dot lines are boundary lines intended to define claimed and unclaimed areas of the design.  
Further, the element may be of any color/shade or combination of colors/shades.  
Still further, precise length of the article is not claimed.

**1 Claim, 7 Drawing Sheets**

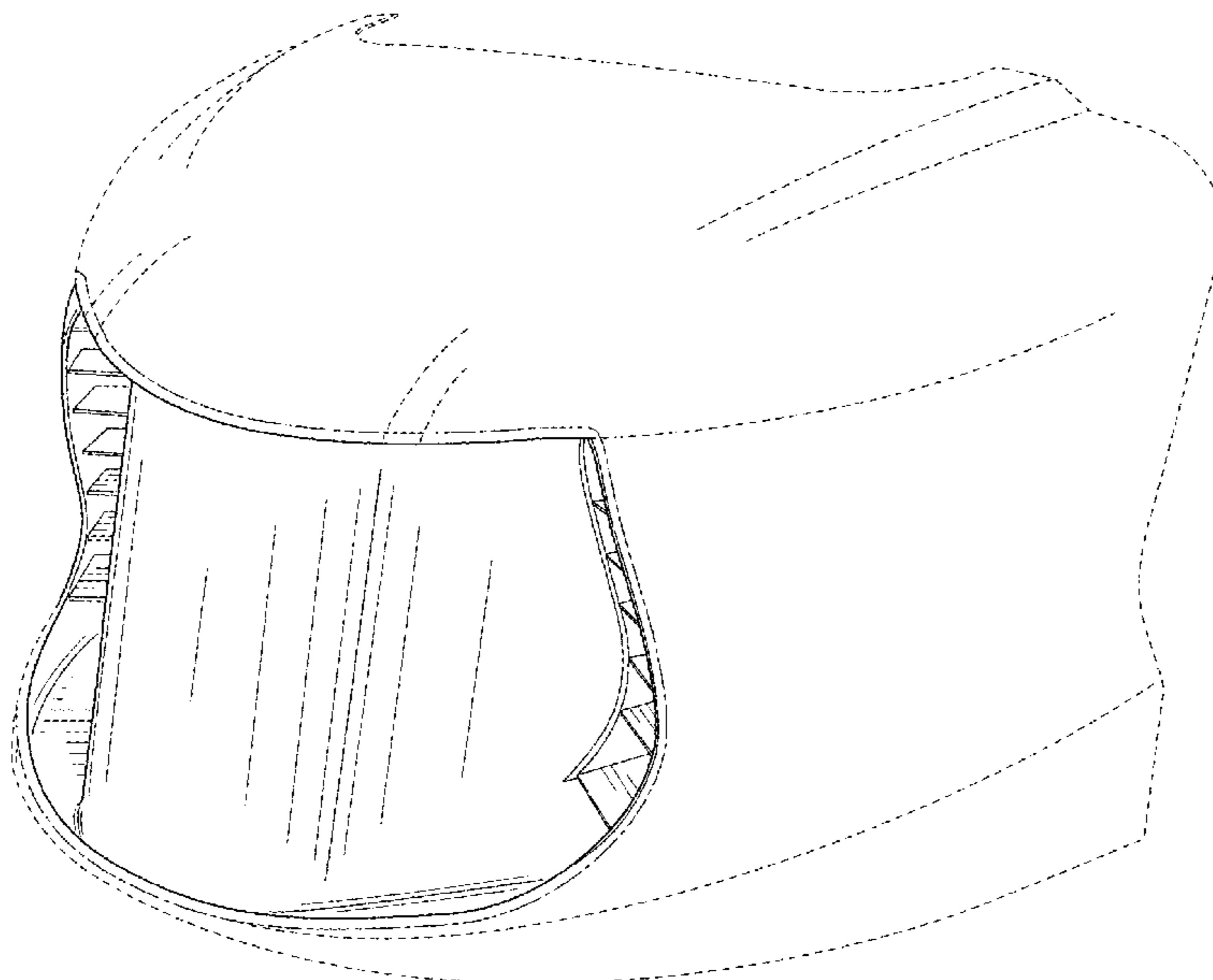

**Related U.S. Application Data**

division of application No. 29/549,893, filed on Dec. 29, 2015, now Pat. No. Des. 820,749.

(58) **Field of Classification Search**

CPC ..... B32B 3/00; B60S 9/205  
See application file for complete search history.

(56) **References Cited**

U.S. PATENT DOCUMENTS

3,842,944 A 10/1974 Shiotani et al.  
3,887,223 A 6/1975 Bez  
4,103,957 A 8/1978 Landry et al.  
4,227,593 A 10/1980 Bricmont et al.  
4,245,862 A 1/1981 Buckley, Jr.  
4,290,639 A 9/1981 Herpel  
4,318,566 A 3/1982 Fitzjarrell  
4,343,506 A 8/1982 Saltzman  
4,408,792 A 10/1983 Sullivan  
4,611,796 A 9/1986 Orr  
4,890,877 A 1/1990 Ashtiani-Zarandi et al.  
4,932,716 A 6/1990 Marlowe et al.  
4,957,322 A 9/1990 Marlowe et al.  
5,018,779 A 5/1991 Lund  
5,139,297 A 8/1992 Carpenter et al.  
5,150,935 A 9/1992 Glance et al.  
5,174,626 A 12/1992 Wiley, Jr. et al.  
5,249,837 A 10/1993 Luttrell  
5,306,066 A 4/1994 Saathoff  
5,480,729 A 1/1996 Hattori et al.  
5,618,074 A 4/1997 Weast  
5,715,917 A 2/1998 Smallwood  
5,746,419 A 5/1998 McFadden et al.  
5,755,485 A 5/1998 Christie et al.  
5,819,408 A 10/1998 Catlin  
6,099,069 A 8/2000 Spears  
D436,894 S 1/2001 Barraclough et al.  
6,183,041 B1 2/2001 Wilson  
6,217,107 B1 4/2001 Langlois  
6,299,958 B1 10/2001 St. Julien et al.  
6,394,512 B1 5/2002 Schuster et al.  
6,467,822 B1 10/2002 Leng  
6,494,510 B2 12/2002 Okamura et al.  
6,503,585 B1 1/2003 Wagenblast et al.  
6,513,843 B1 2/2003 Frederick et al.  
6,540,275 B1 4/2003 Iwamoto et al.  
6,547,295 B2 4/2003 Vismara  
D475,657 S 6/2003 Wong et al.  
6,685,243 B1 2/2004 Evans  
6,866,294 B2 3/2005 Horsch et al.  
6,866,331 B2 3/2005 Kropfeld  
6,905,136 B2 6/2005 Vidal et al.  
6,938,936 B2 9/2005 Moojiman et al.  
6,991,281 B2 1/2006 Spence et al.  
7,004,502 B2 2/2006 Borroni-Bird et al.  
7,044,514 B2 5/2006 Mustafa et al.  
7,086,690 B2 8/2006 Shuler et al.  
7,121,614 B2 10/2006 Kawai  
7,134,700 B2 11/2006 Evans  
7,163,243 B2 1/2007 Evans  
7,222,896 B2 5/2007 Evans  
D555,597 S 11/2007 Phung et al.  
7,434,872 B2 10/2008 Steller  
7,517,006 B2 4/2009 Kageyama et al.  
7,520,561 B2 4/2009 Nakamae et al.  
D595,628 S 7/2009 Boyd  
7,568,746 B2 8/2009 Jaarda et al.  
D600,606 S \* 9/2009 Lamm ..... D12/169  
7,597,383 B2 10/2009 Itou et al.  
7,607,720 B2 10/2009 Noyori et al.  
7,699,383 B2 4/2010 Fukukawa et al.  
7,806,448 B2 10/2010 Allen et al.  
7,879,435 B2 2/2011 Mett et al.  
7,938,462 B2 5/2011 Nilsson  
8,162,382 B2 4/2012 Hjelm et al.  
D666,541 S 9/2012 Stimel, Jr.

D670,217 S 11/2012 Bobba et al.  
D670,218 S 11/2012 Bobba et al.  
8,322,780 B2 12/2012 Nagwanshi et al.  
8,348,313 B2 1/2013 Chickmenahalli et al.  
8,403,400 B2 3/2013 Brewer  
8,469,417 B2 6/2013 Di Modugno  
8,474,583 B2 7/2013 Nagwanshi et al.  
D687,359 S 8/2013 Peltola et al.  
8,505,990 B2 8/2013 Czopek et al.  
D696,169 S 12/2013 Mana et al.  
D699,648 S 2/2014 Sancer et al.  
D707,605 S 6/2014 Duncan et al.  
D707,608 S 6/2014 Smith  
D709,007 S 7/2014 Morris et al.  
D709,008 S 7/2014 Brzustowicz et al.  
D709,009 S 7/2014 Brzustowicz et al.  
D710,773 S \* 8/2014 Ito ..... D12/181  
8,801,077 B2 8/2014 Vogel et al.  
8,807,628 B1 8/2014 Pfaff  
8,807,630 B2 8/2014 Rode et al.  
8,864,216 B2 10/2014 Nagwanshi et al.  
8,905,444 B2 12/2014 Zannier  
D722,544 S \* 2/2015 Ito ..... D12/181  
9,033,380 B2 5/2015 Mana et al.  
D731,382 S 6/2015 Mana et al.  
9,050,939 B2 6/2015 Marur et al.  
D752,488 S 3/2016 Peltola et al.  
D758,253 S \* 6/2016 Brzustowicz ..... D12/96  
D760,633 S 7/2016 Peltola et al.  
D772,127 S 11/2016 Heilaneh et al.  
D773,360 S 12/2016 Heilaneh et al.  
D780,648 S 3/2017 Pereira et al.  
D782,947 S 4/2017 Sausaman et al.  
D813,772 S \* 3/2018 Anderson ..... D12/196  
D814,376 S \* 4/2018 Anderson ..... D12/196  
D820,749 S 6/2018 Schellekens et al.  
D827,498 S \* 9/2018 Anderson ..... D12/96  
D881,097 S \* 4/2020 Smith ..... D12/196  
D882,466 S \* 4/2020 Yong ..... D12/169  
D885,272 S \* 5/2020 Smith ..... D12/181  
D889,336 S \* 7/2020 Smith ..... D12/181  
2001/0026072 A1 10/2001 Sato et al.  
2002/0017805 A1 2/2002 Carroll, III et al.  
2002/0043809 A1 4/2002 Vismara  
2002/0050413 A1 5/2002 Renault  
2002/0070584 A1 6/2002 Carroll, III et al.  
2002/0125725 A1 9/2002 Satou  
2002/0129981 A1 9/2002 Satou  
2002/0180223 A1 12/2002 Vismara et al.  
2003/0034658 A1 2/2003 Cate et al.  
2003/0067179 A1 4/2003 Bastien et al.  
2003/0164618 A1 9/2003 Gentle  
2004/0051321 A1 3/2004 Hanai et al.  
2004/0124643 A1 7/2004 Matsumoto et al.  
2004/0174025 A1 9/2004 Converse et al.  
2006/0119116 A1 6/2006 Goertz  
2006/0181089 A1 8/2006 Andre et al.  
2006/0261611 A1 11/2006 Mohapatra et al.  
2007/0069535 A1 3/2007 Mohapatra et al.  
2007/0122510 A1 5/2007 Mendiboure et al.  
2007/0200376 A1 8/2007 Jaarda et al.  
2007/0257513 A1 11/2007 Schwartz  
2008/0048462 A1 2/2008 Zabik  
2008/0197663 A1 8/2008 Smith  
2008/0246277 A1 10/2008 Gallagher et al.  
2008/0286522 A1 11/2008 Khan et al.  
2009/0160203 A1 6/2009 Garg et al.  
2009/0309387 A1 12/2009 Goral et al.  
2010/0201040 A1 8/2010 Guichard et al.  
2010/0244472 A1 9/2010 Gonin et al.  
2011/0316307 A1 12/2011 Di Modugno  
2012/0104778 A1 5/2012 Mana et al.  
2012/0112479 A1 5/2012 Nagwanshi et al.  
2012/0153643 A1 6/2012 Mana et al.  
2012/0153669 A1 6/2012 Nagwanshi et al.  
2013/0106139 A1 5/2013 Nagwanshi et al.  
2014/0203577 A1 7/2014 Nagwanshi et al.



(56)

**References Cited**

U.S. PATENT DOCUMENTS

2014/0203592 A1 7/2014 Nagwanshi et al.  
 2017/0120964 A1\* 5/2017 Kim ..... B62D 35/001

FOREIGN PATENT DOCUMENTS

CN 101529118 A 9/2009  
 DE 102006032867 A1 1/2008  
 DE 102007038087 A1 2/2009  
 DE 102011104368 A1 3/2012  
 EP 0661198 A1 7/1995  
 EP 1065108 A2 1/2001  
 EP 1104857 A1 6/2001  
 EP 1300293 A9 4/2003  
 EP 1369309 A1 12/2003  
 EP 1419936 A1 5/2004  
 EP 1473197 A1 11/2004  
 EP 1652733 A1 5/2006  
 EP 1759959 A2 3/2007  
 EP 2380782 A1 10/2011  
 FR 2702432 A1 9/1994  
 FR 2859970 A1 3/2005  
 FR 2864811 A1 7/2005  
 FR 2887508 A1 12/2006  
 FR 2890361 A1 3/2007  
 GB 2384217 A 7/2003  
 GB 2386937 A 10/2003  
 GB 2459186 A 10/2009  
 JP S5739881 U 3/1982  
 JP S5795264 A 6/1982  
 JP 2001334962 A 12/2001  
 JP 2006247237 A 9/2006  
 JP 2014004973 A 1/2014  
 WO 2005100100 A1 10/2005  
 WO 2005105554 A1 11/2005  
 WO 2006008150 A1 1/2006

WO 2006065868 A2 6/2006  
 WO 2006119225 A2 11/2006  
 WO 2006136743 A1 12/2006  
 WO 2008016653 A2 2/2008  
 WO 2008140362 A1 11/2008  
 WO 2010026444 A1 3/2010  
 WO 2010103449 A1 9/2010  
 WO 2010109405 A1 9/2010  
 WO 2012014091 A1 2/2012  
 WO 2012040826 A1 4/2012  
 WO 2012042396 A1 4/2012  
 WO 2013007386 A1 1/2013  
 WO 2013082484 A1 6/2013  
 WO 2014113580 A1 7/2014

OTHER PUBLICATIONS

European Patent for the corresponding application, European Patent No. 0661198 (A1), Publication Date: Jul. 5, 1995; Abstract Only; 2 pages.  
 Galipeau-Belair, "Design and Development of Side Underride Protection Devices (SUPD) for Heavy Vehicles," Master Degree Thesis, (Apr. 2014), 134 pages.  
 International Search Report for International Application No. PCT/US2015/060529; dated Feb. 3, 2016; 7 pages.  
 Japanese Patent No. 2001334962A; Date of Publication: Dec. 4, 2001; Abstract Only, 2 pages.  
 Japanese Patent No. S5739881U; Date of Publication: Mar. 3, 1982; English translation; 7 pages.  
 Japanese Patent No. S5795264A; Date of Publication: Jun. 14, 1982; Abstract Only, 2 pages.  
 Written Opinion of the International Search Report for International Application No. PCT/US2015/060529; dated Feb. 3, 2016; 10 pages.

\* cited by examiner

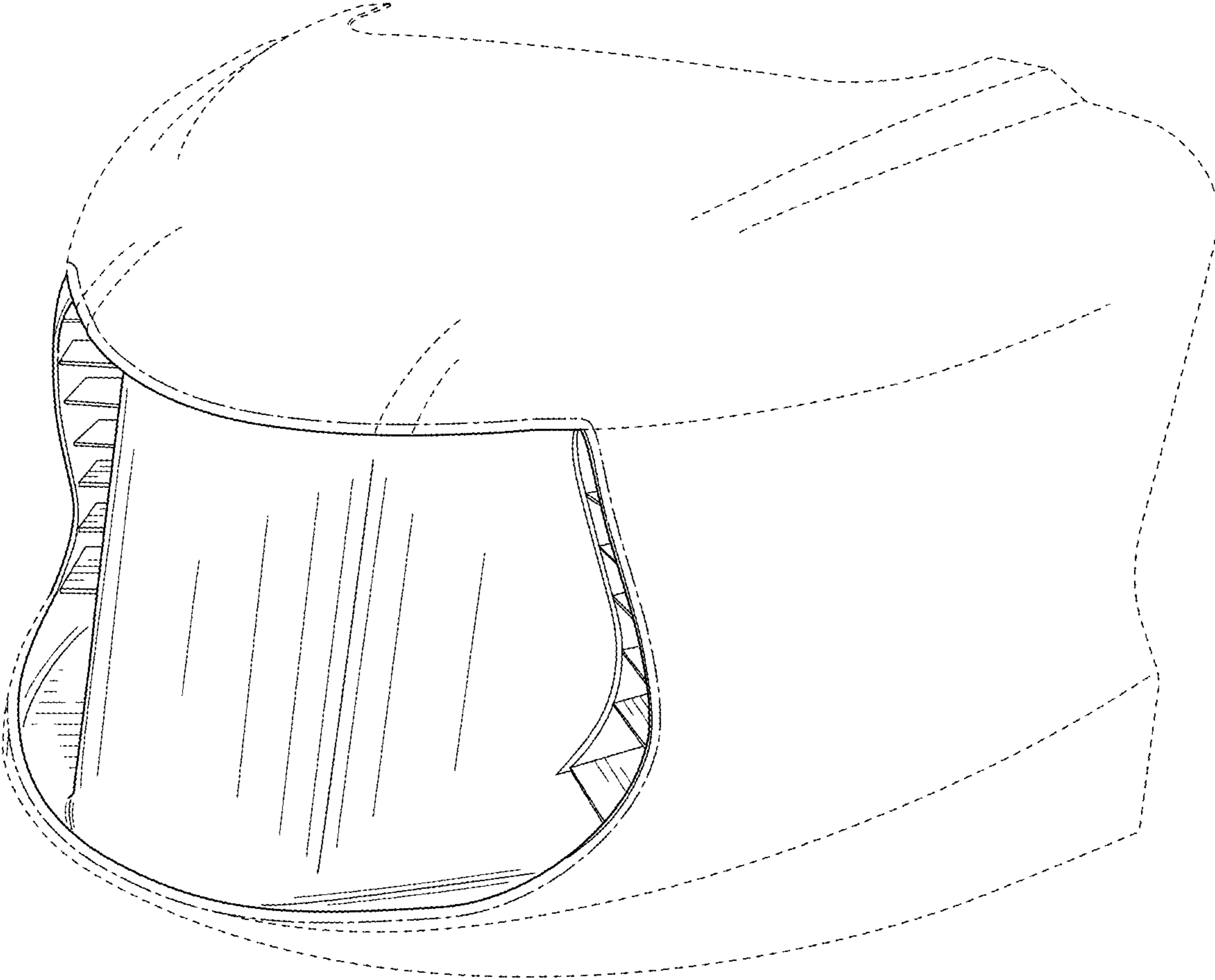

FIG. 1

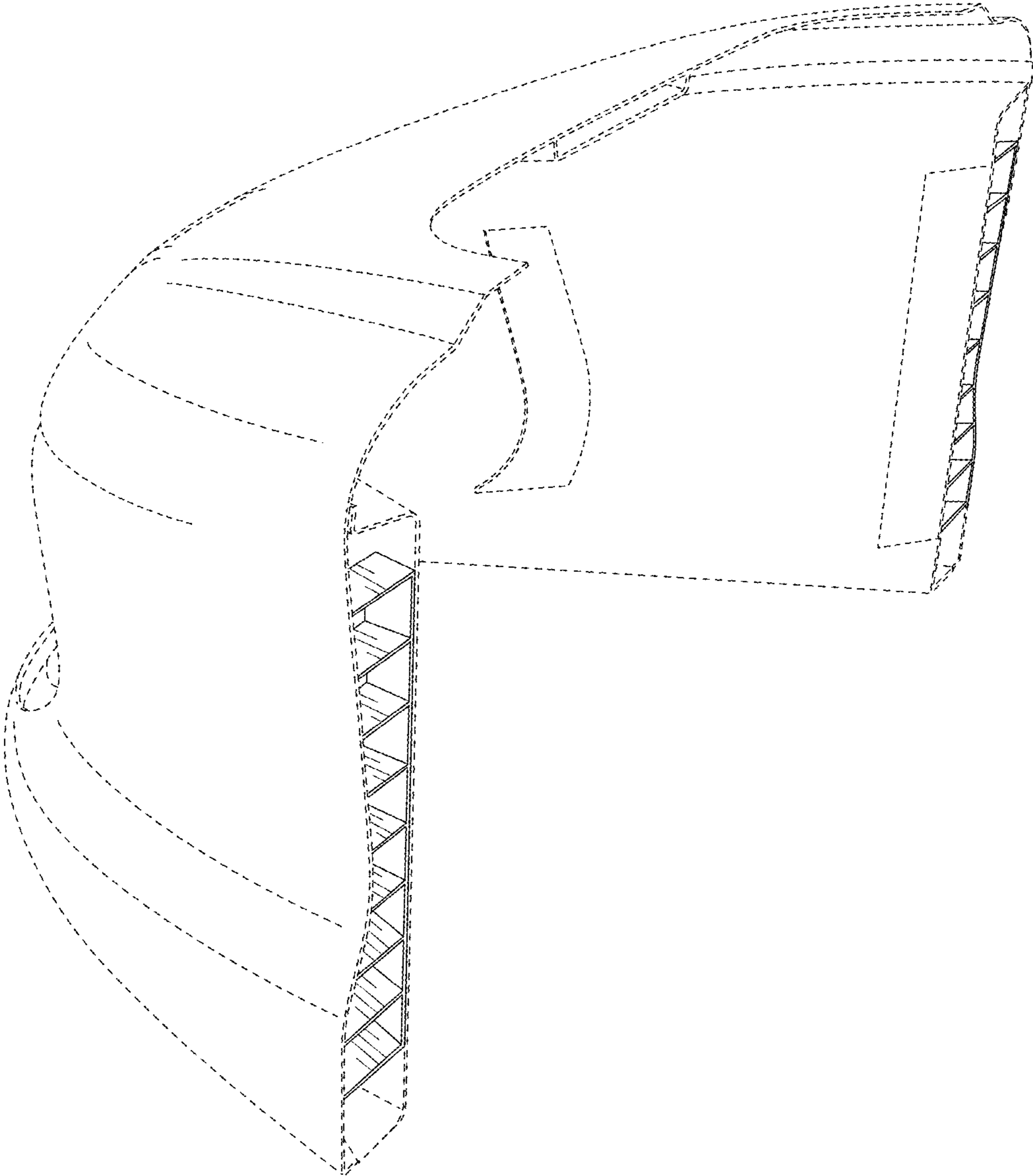

FIG. 2

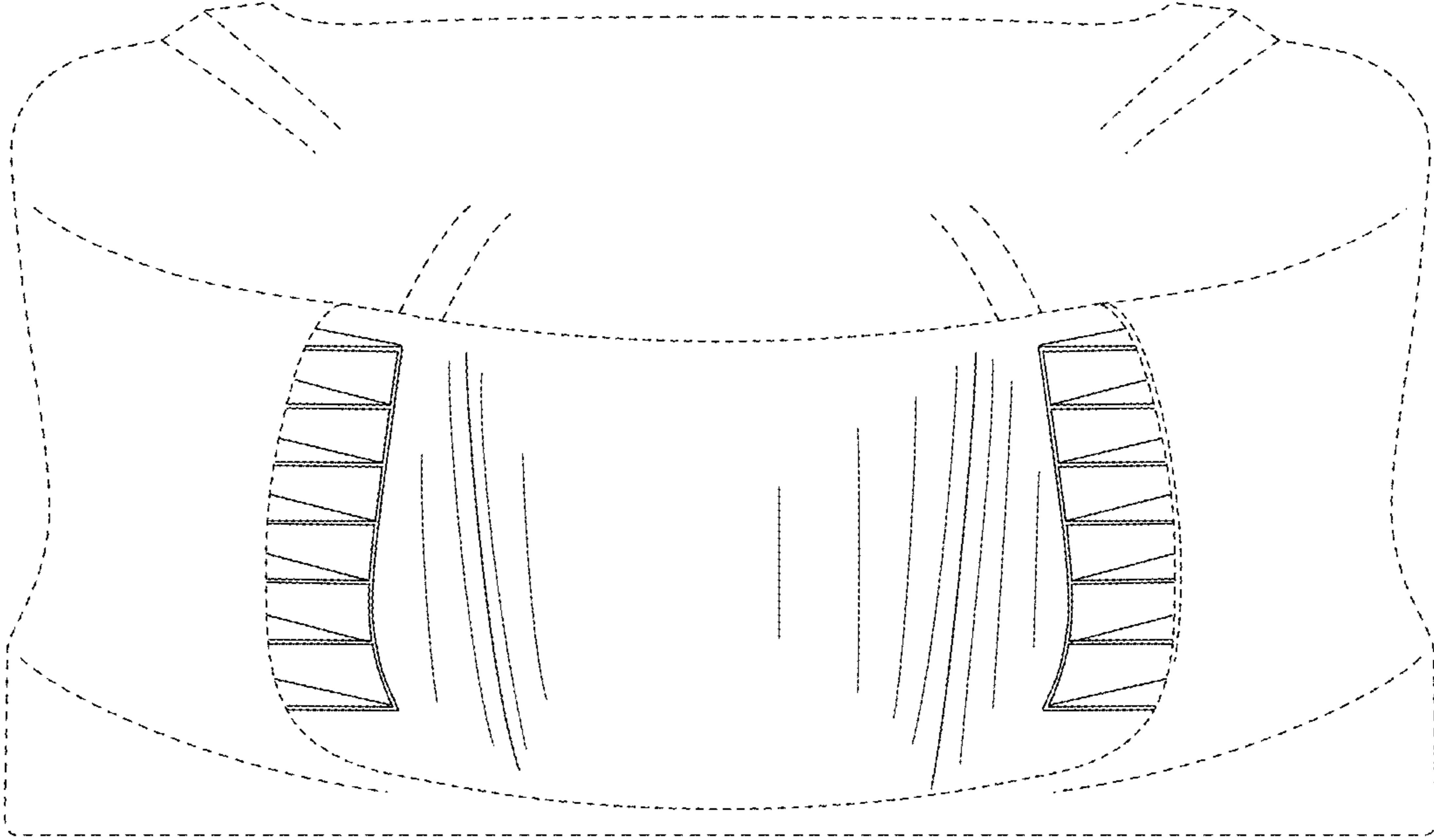

FIG. 3

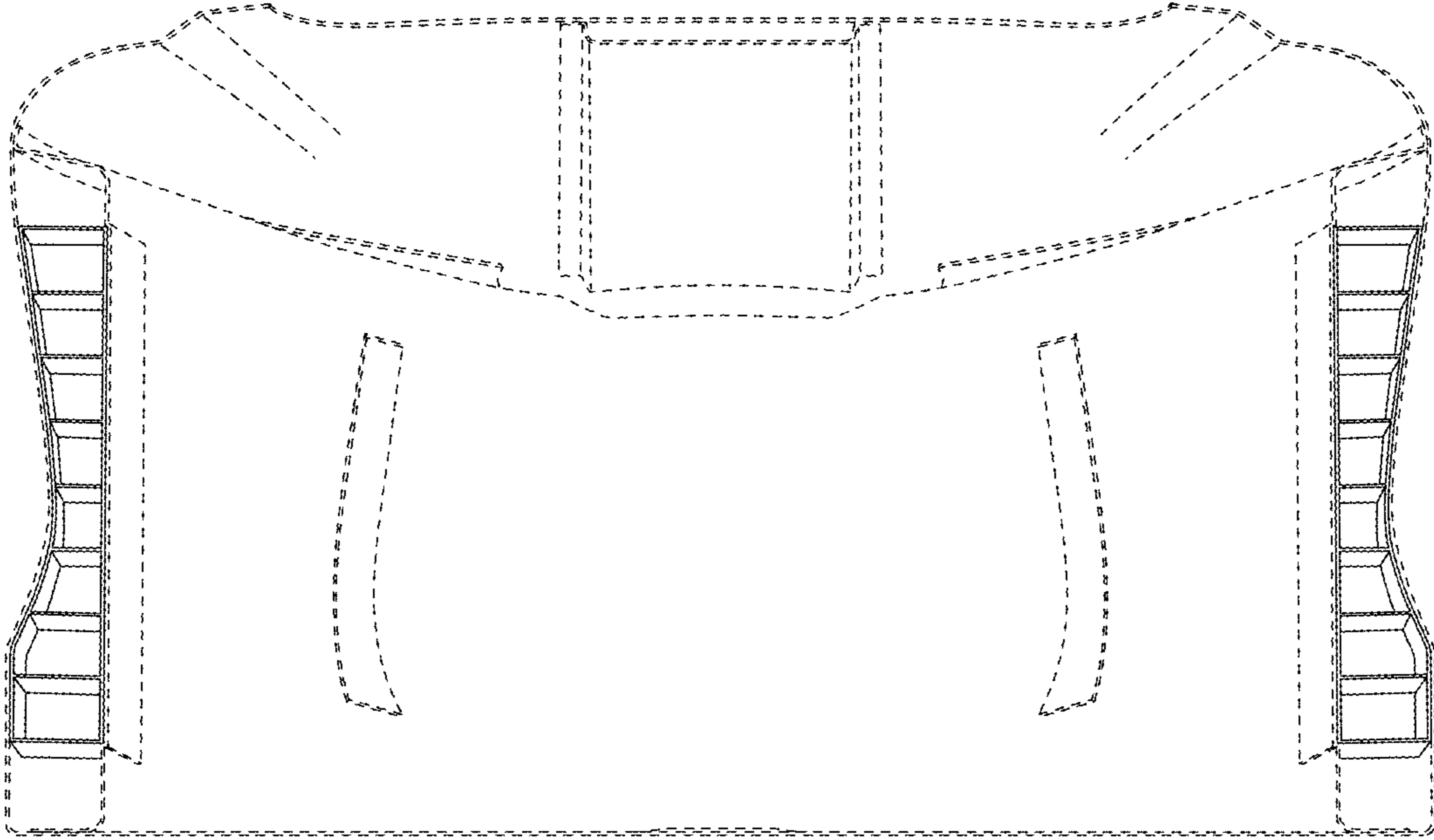

FIG. 4

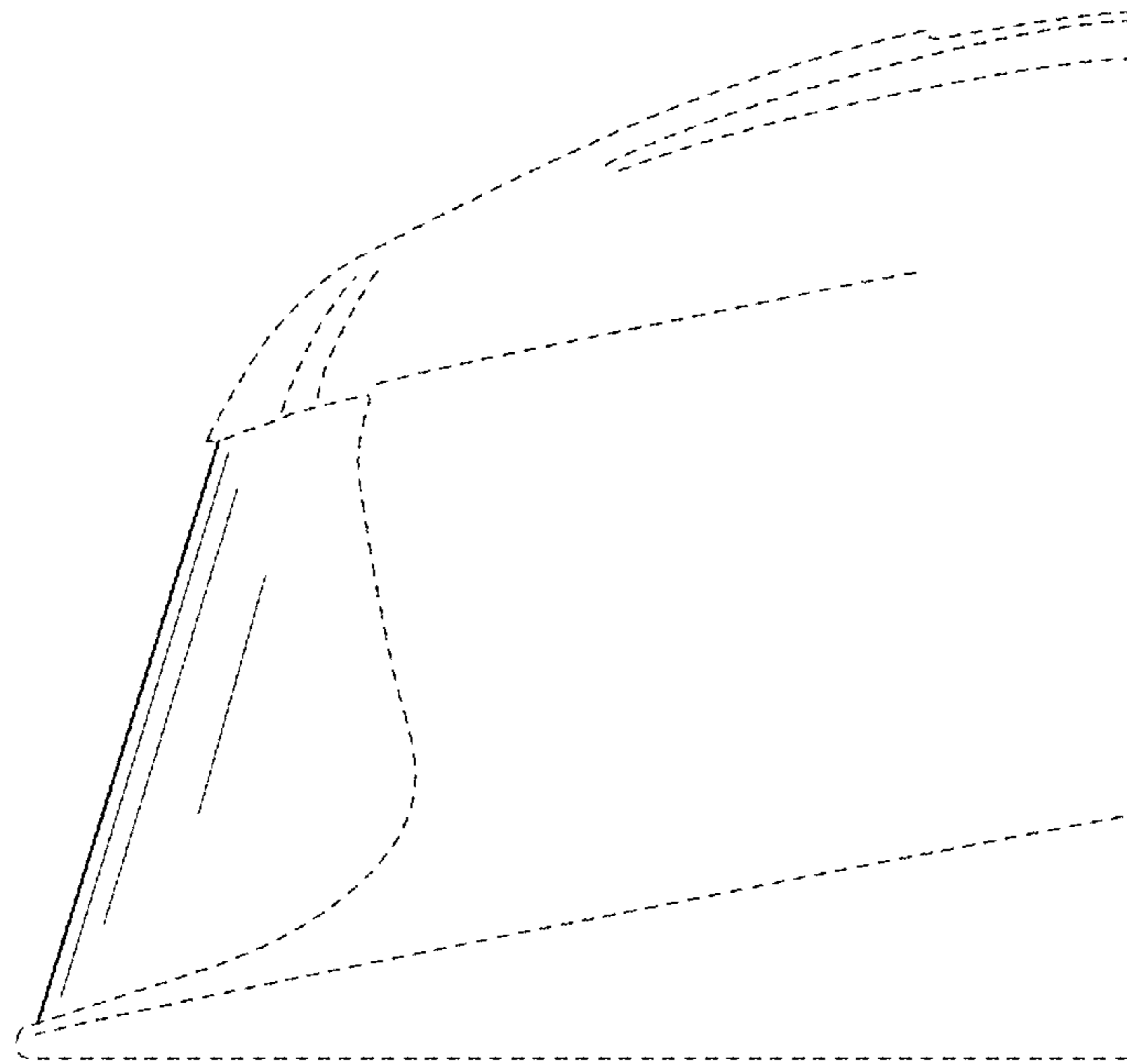

FIG. 5

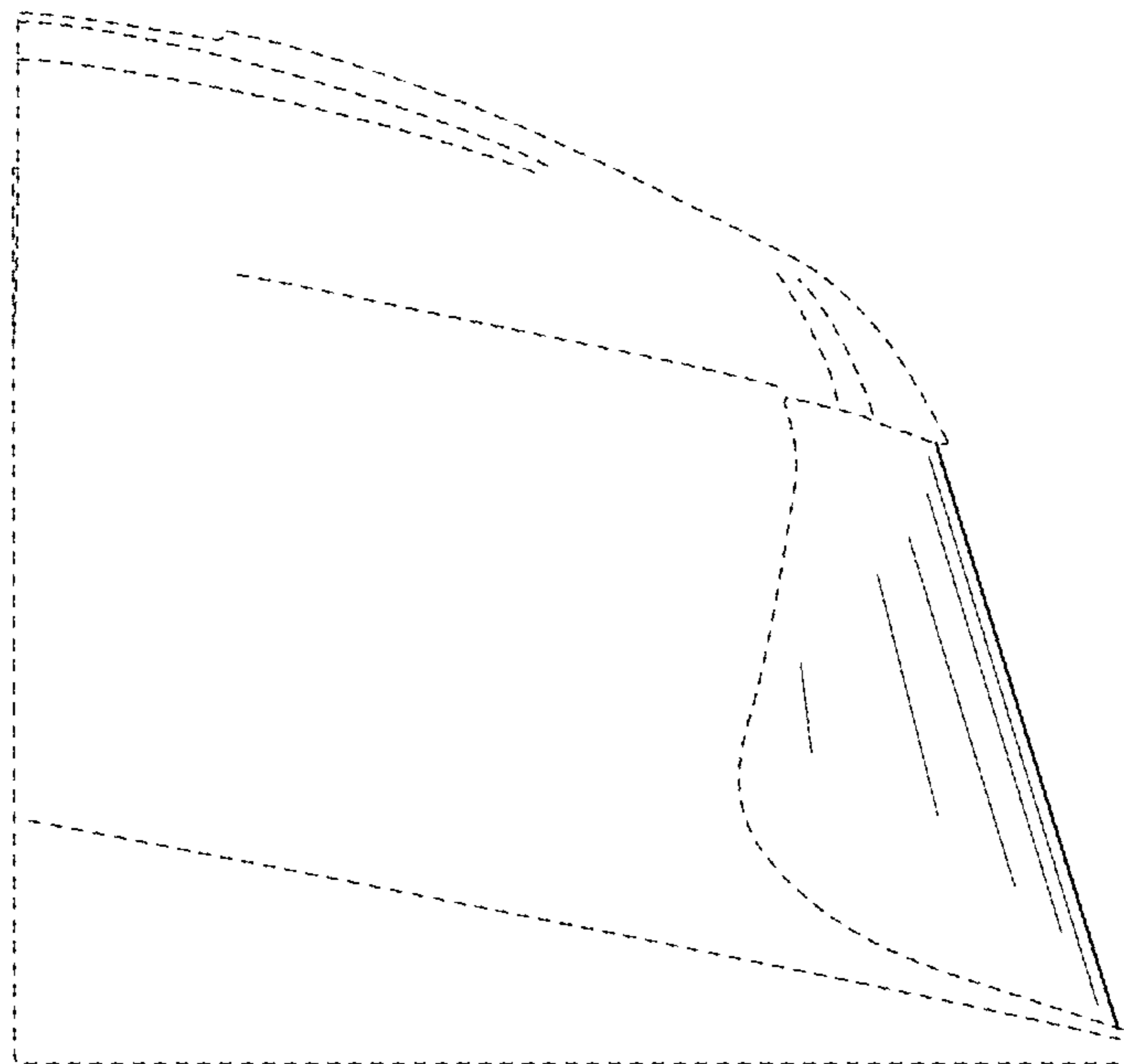

FIG. 6

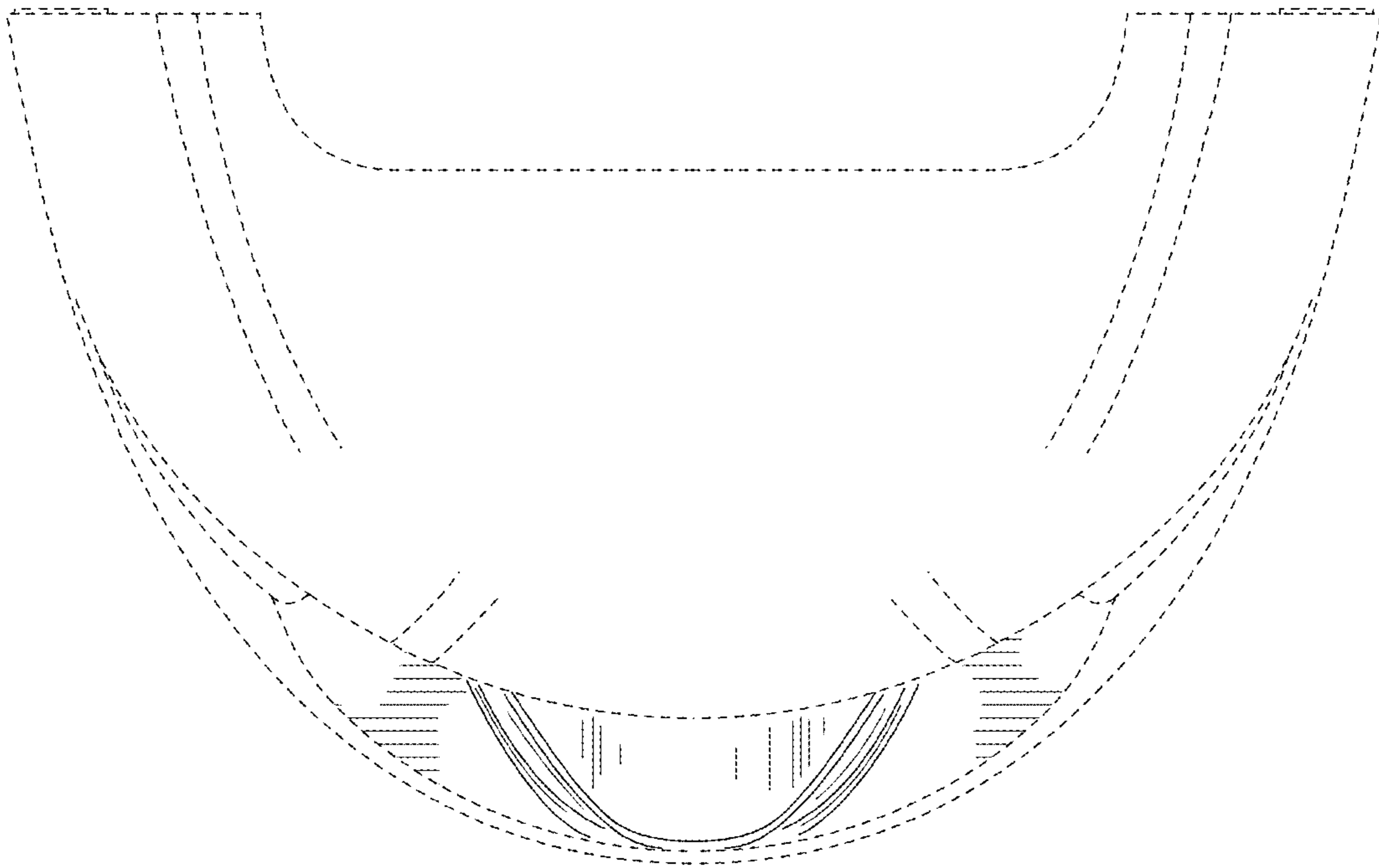

FIG. 7



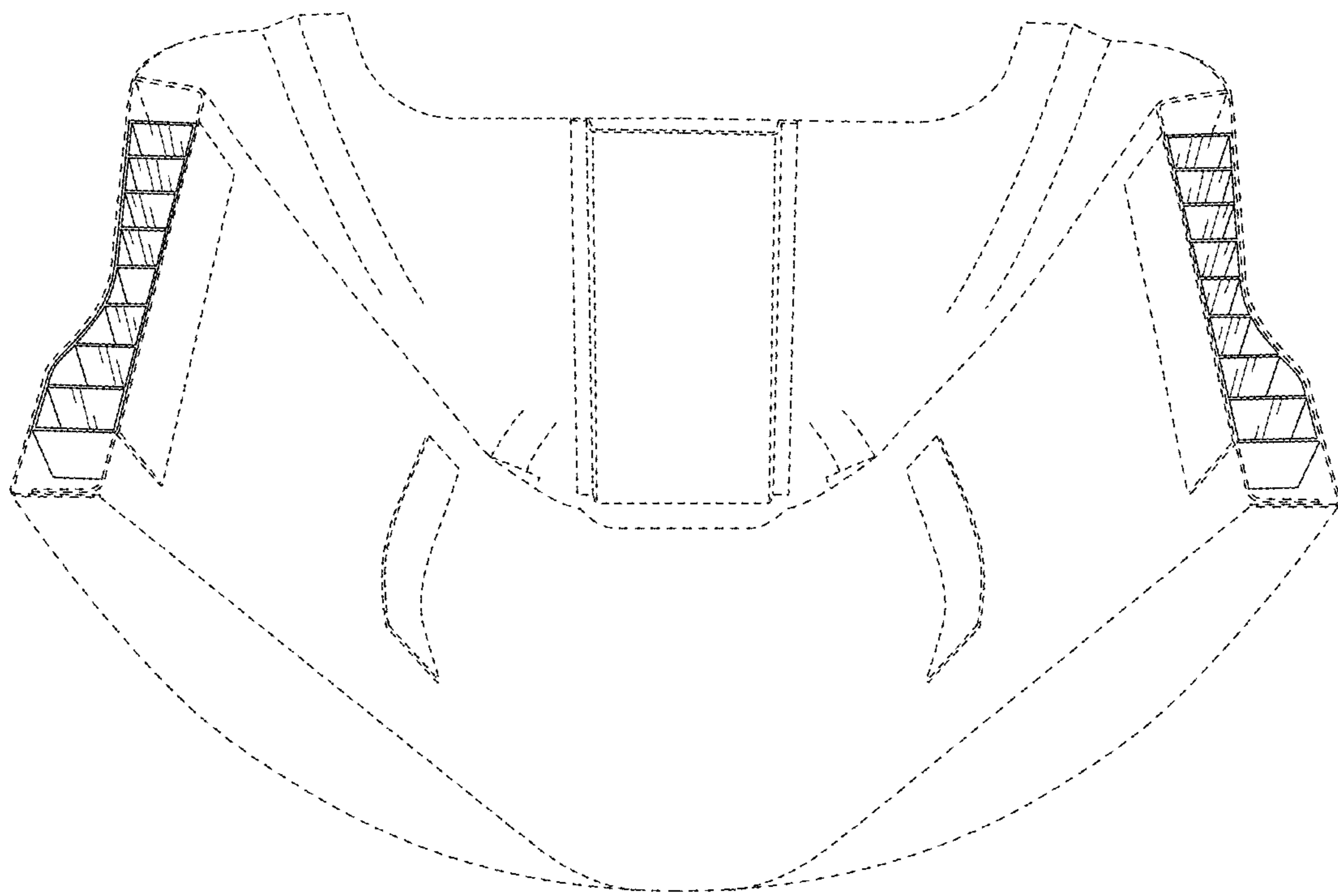

FIG. 8

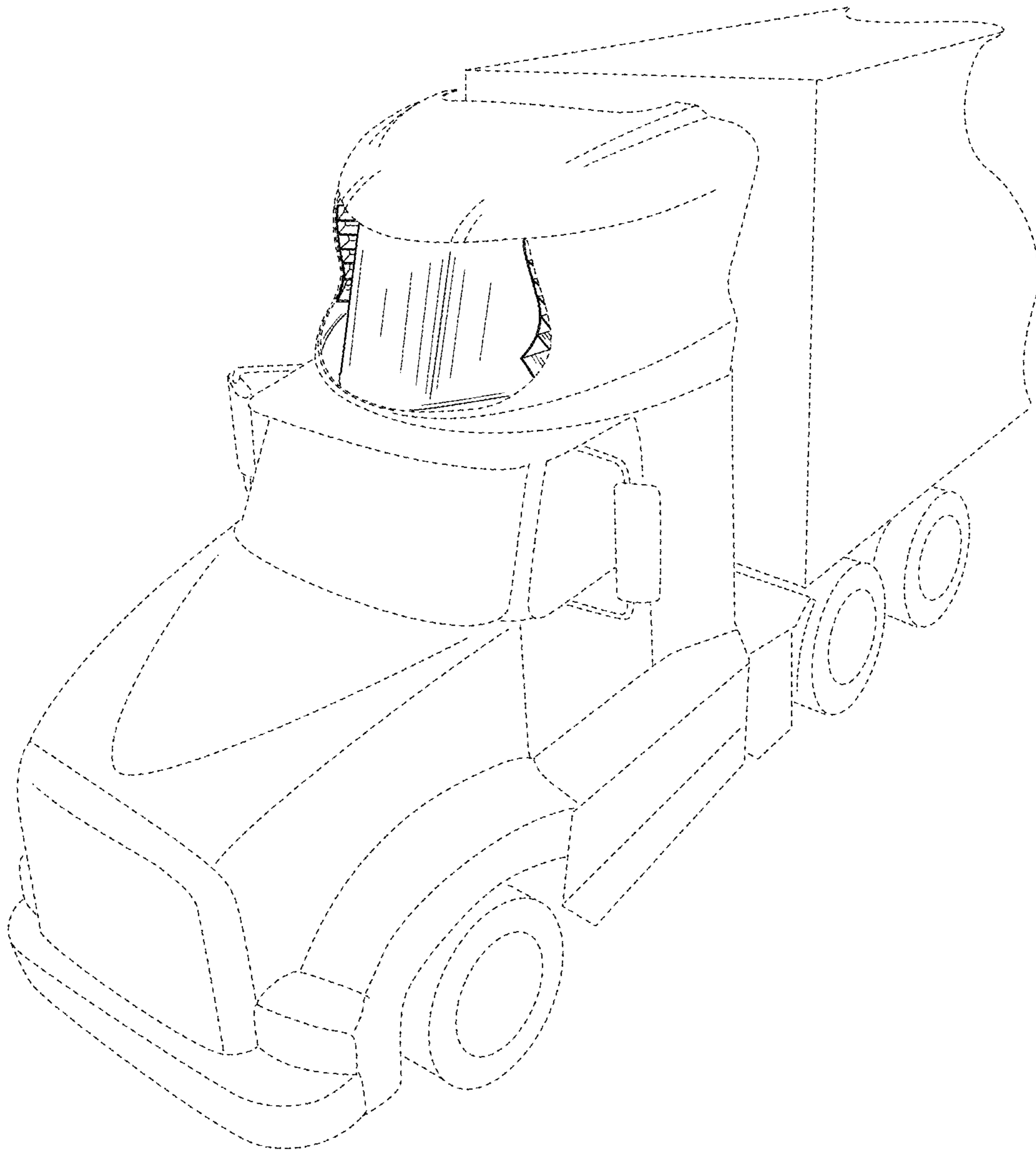

FIG. 9