



US00D901319S

(12) **United States Design Patent**  
**Fuentes**

(10) **Patent No.:** **US D901,319 S**

(45) **Date of Patent:** **\*\* Nov. 10, 2020**

- (54) **BEACON**
- (71) Applicant: **ECCO Safety Group (UK) Limited**,  
Leeds (GB)
- (72) Inventor: **Francisco Paz Fuentes**, Wakefield  
(GB)
- (73) Assignee: **ECCO Safety Group (UK) Limited**,  
Leeds (GB)
- (\*\*) Term: **15 Years**
- (21) Appl. No.: **29/704,647**
- (22) Filed: **Sep. 6, 2019**
- (51) **LOC (12) Cl.** ..... **10-05**
- (52) **U.S. Cl.**  
USPC ..... **D10/114.2**
- (58) **Field of Classification Search**  
USPC ..... D10/106.1–106.95, 109.1–115; D14/204,  
D14/209, 210, 215, 216; D26/37, 60, 72  
CPC ..... F21L 4/00–085  
See application file for complete search history.

- D612,760 S \* 3/2010 Chen ..... D10/114.8
- D668,982 S \* 10/2012 Hsiao ..... D10/114.2
- D669,806 S \* 10/2012 Stein ..... F21V 5/04  
D10/114.2
- D669,807 S \* 10/2012 Stein ..... D10/114.2
- D673,869 S \* 1/2013 Yu ..... D10/114.2
- D684,078 S \* 6/2013 Clifford ..... D10/114.2
- D701,466 S \* 3/2014 Clifford ..... B60Q 1/2611  
D10/114.2
- 9,228,713 B2 \* 1/2016 Skertich, Jr. .... F21V 5/04

\* cited by examiner

*Primary Examiner* — George D. Kirschbaum

*Assistant Examiner* — Joseph J Kukella

(74) *Attorney, Agent, or Firm* — Stoel Rives LLP; Robert R. Teel

(57) **CLAIM**

The ornamental design for a beacon, substantially as shown and described.

**DESCRIPTION**

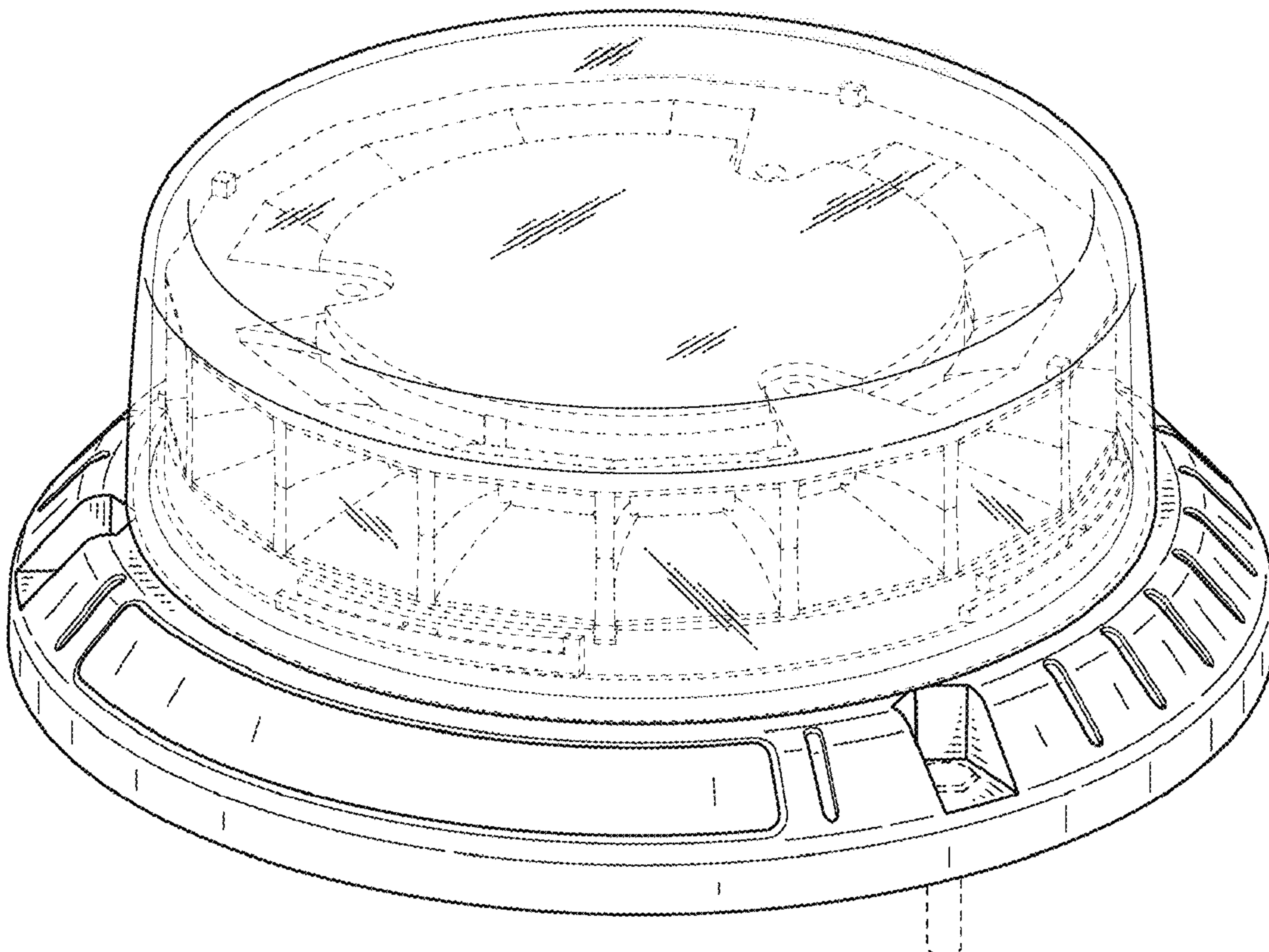
FIG. 1 is a first top isometric view of a beacon;  
 FIG. 2 is a first side elevational view thereof;  
 FIG. 3 is a second side elevational view thereof;  
 FIG. 4 is a third side elevational view thereof;  
 FIG. 5 is a fourth side elevational view thereof; and,  
 FIG. 6 is a top plan view thereof.  
 In the figures, the broken lines show environmental structures forming no part of the claimed design.

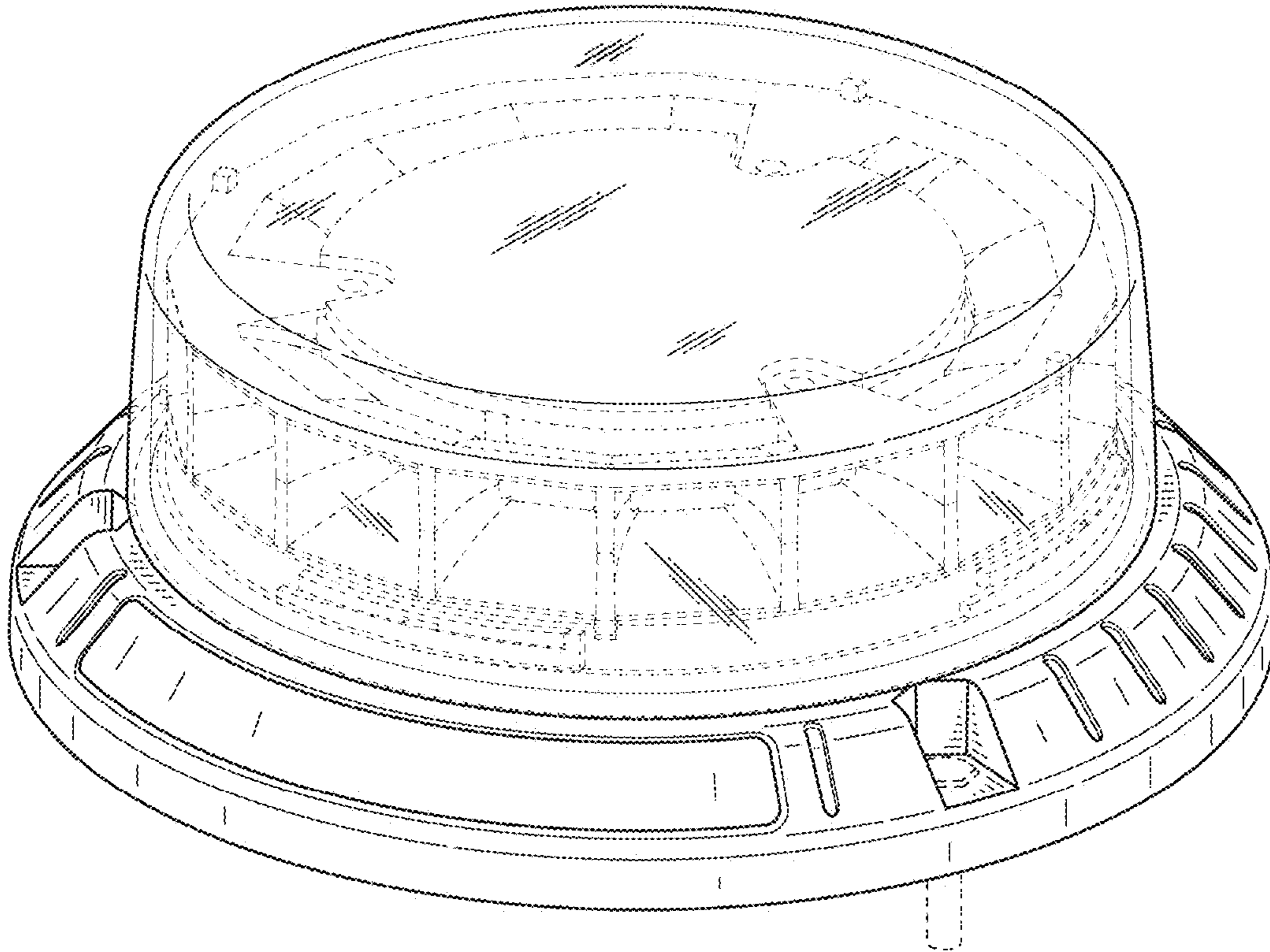
**1 Claim, 3 Drawing Sheets**

(56) **References Cited**

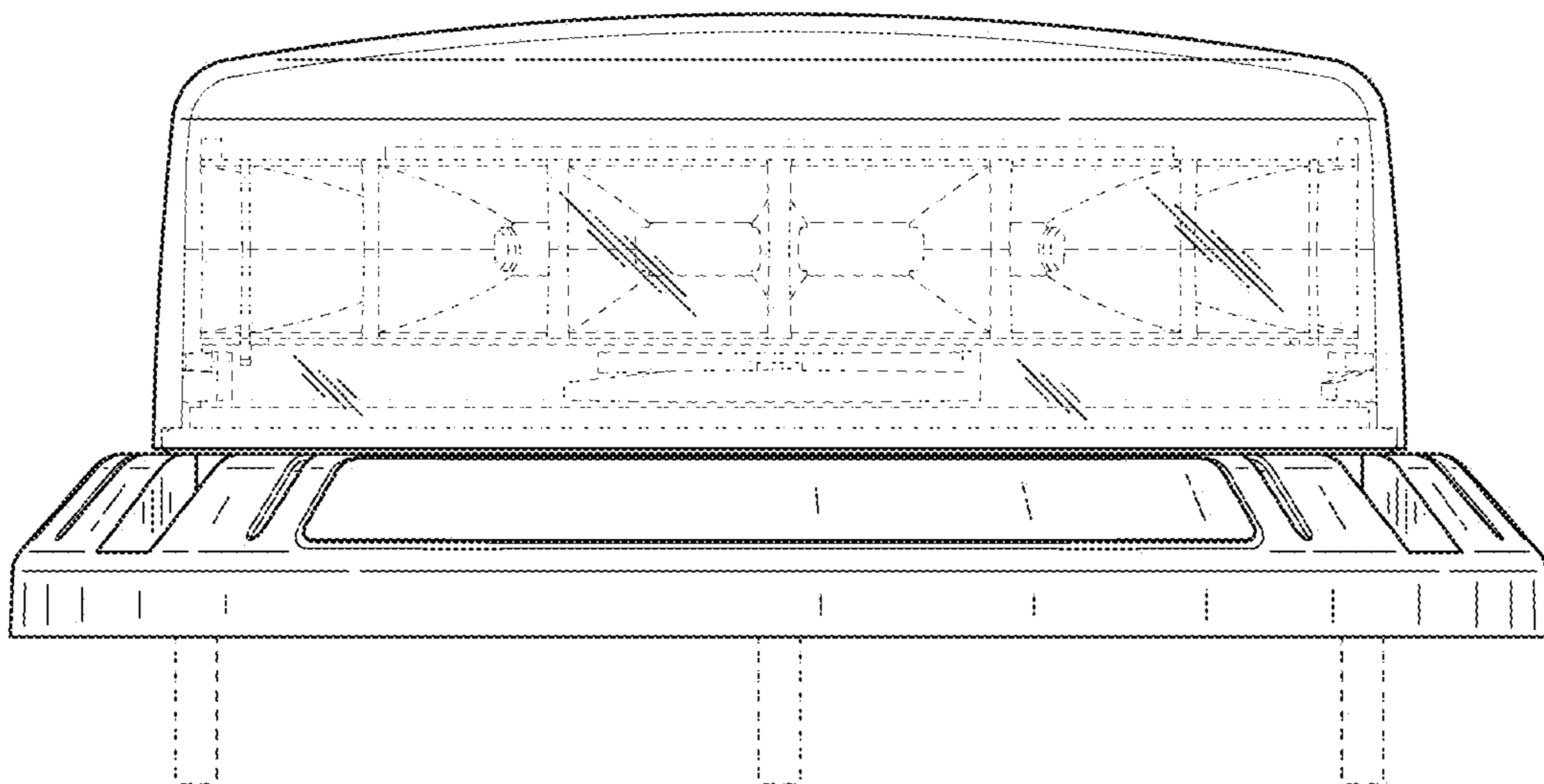
U.S. PATENT DOCUMENTS

- D211,276 S \* 6/1968 Jiruska ..... D10/114.2
- 7,168,827 B2 \* 1/2007 Stein ..... B60Q 1/2611  
362/299
- D570,722 S \* 6/2008 Taylor ..... D10/114.8
- D598,315 S \* 8/2009 Miyatake ..... D10/109.2

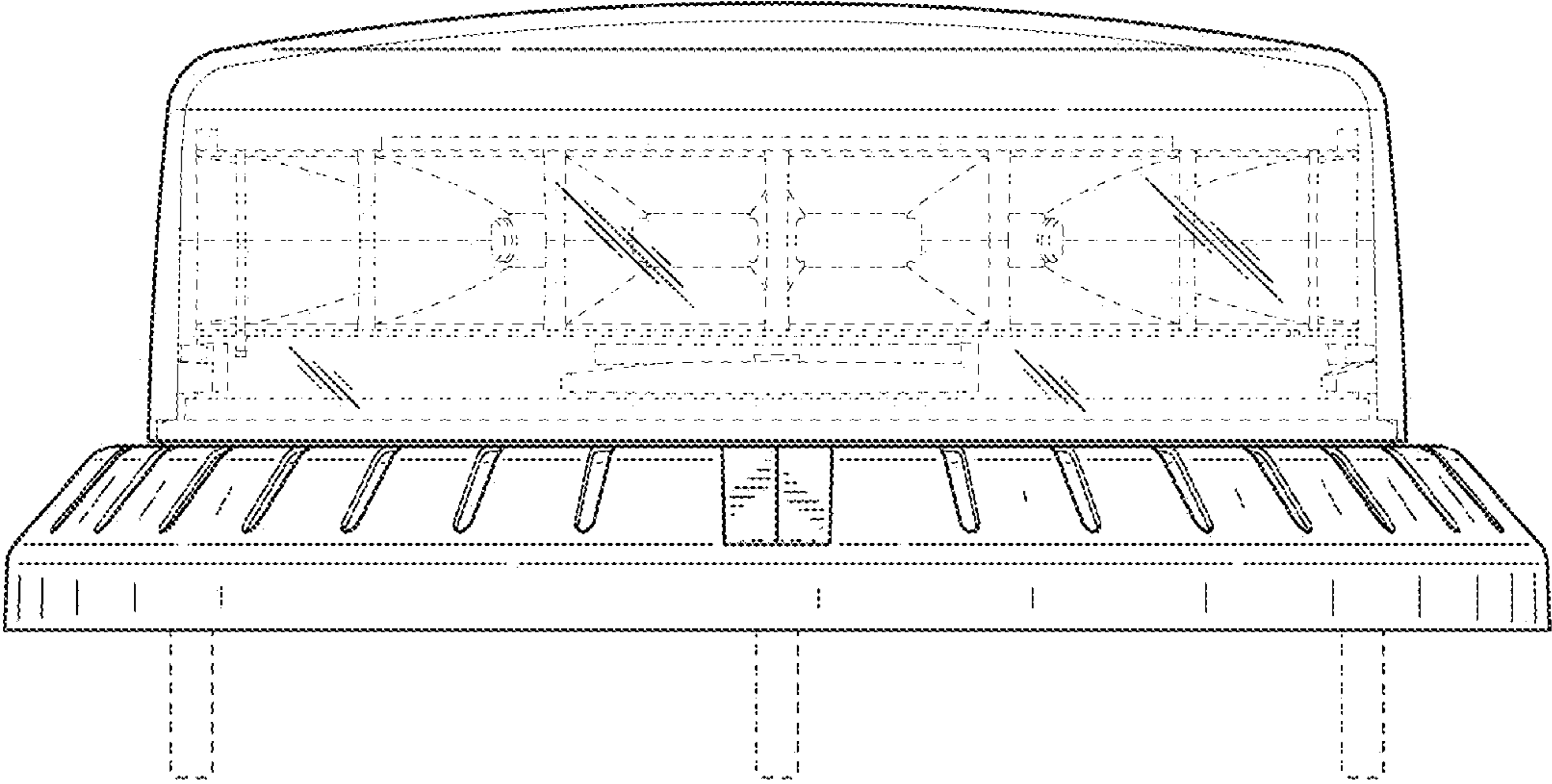




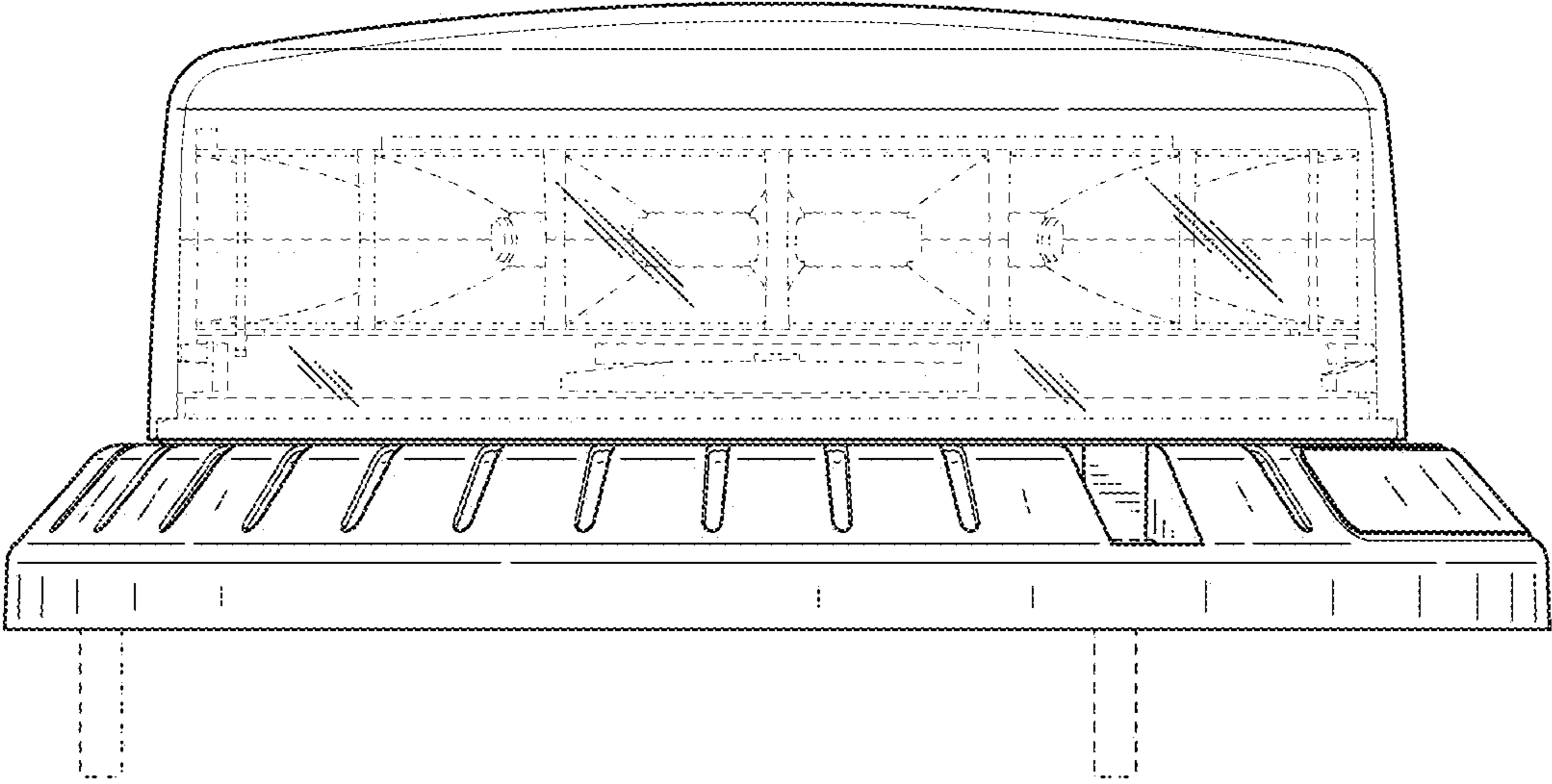
*FIG. 1*



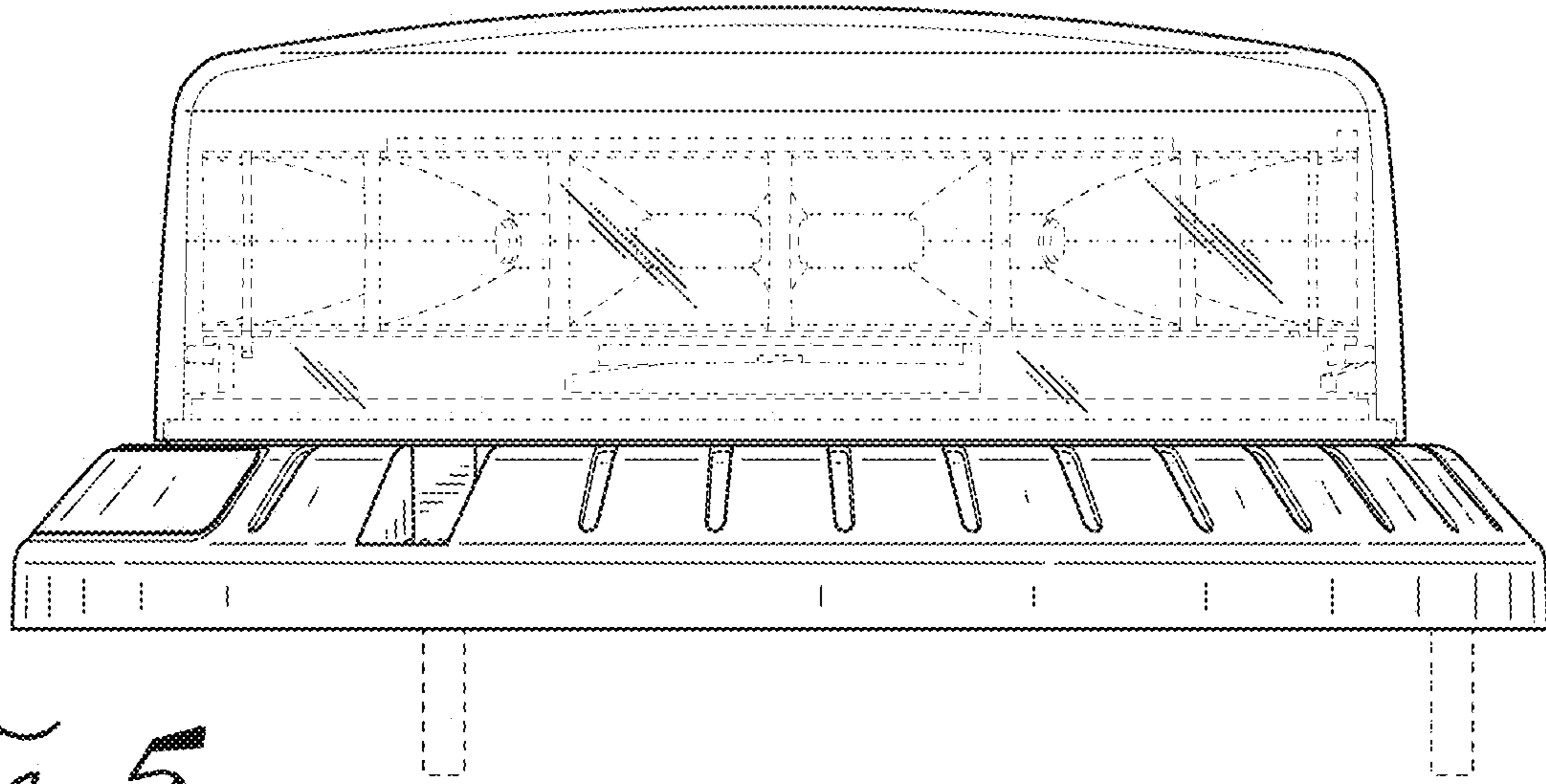
*FIG. 2*



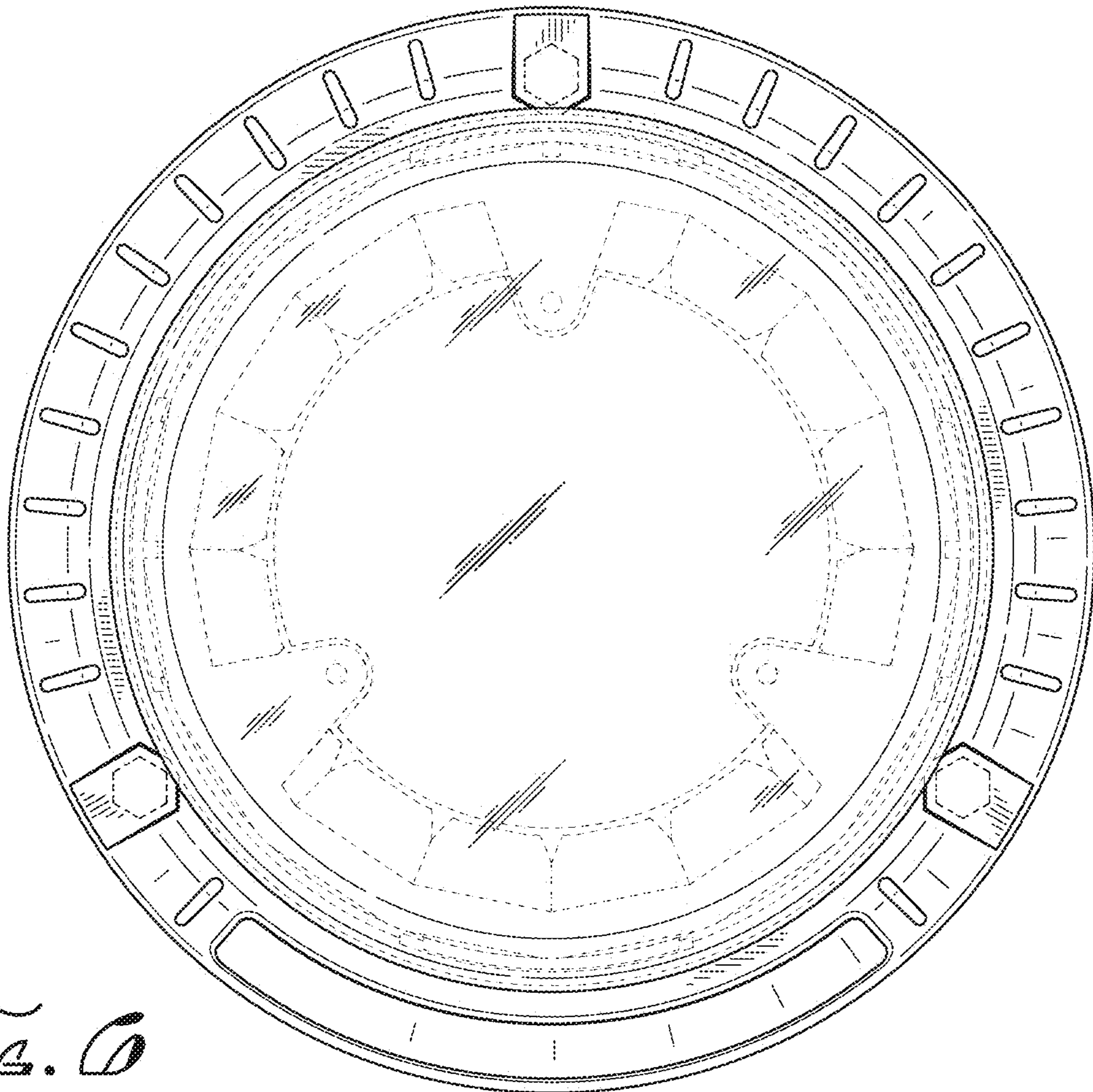
*FIG. 3*



*FIG. 4*



*FIG. 5*



*FIG. 6*