



US00D901198S

(12) **United States Design Patent** (10) **Patent No.:** **US D901,198 S**
Ferrere et al. (45) **Date of Patent:** **** Nov. 10, 2020**

(54) **AIRCRAFT SEAT**

(71) Applicant: **Airbus SAS**, Blagnac (FR)

(72) Inventors: **Nicolas Ferrere**, Toulouse (FR);
Béranger Chantal, Toulouse (FR);
Nadra Chafiq, Toulouse (FR)

(73) Assignee: **AIRBUS INTERIORS SERVICES**,
Blagnac (FR)

(**) Term: **15 Years**

(21) Appl. No.: **29/667,456**

(22) Filed: **Oct. 22, 2018**

(30) **Foreign Application Priority Data**

Apr. 26, 2018 (EM) 005250321-0001
Apr. 26, 2018 (EM) 005250321-0002

(51) **LOC (12) Cl.** **06-01**

(52) **U.S. Cl.**
USPC **D6/356**

(58) **Field of Classification Search**
USPC D6/334-336, 338, 356, 367, 371, 373,
D6/716, 716.1, 716.2, 716.3, 716.4,
D6/716.5; D12/195
CPC B64D 11/00; B64D 11/06; B64D 11/0601;
B64D 11/0602; B64D 11/0605; B64D
11/0606; B64D 11/064; B64D 11/0641;
B64D 11/0647
See application file for complete search history.

(56) **References Cited**

U.S. PATENT DOCUMENTS

D524,211 S * 7/2006 Tsuchiya D12/195
D649,793 S * 12/2011 Porter D6/356
D686,423 S * 7/2013 Salzberger D6/356
D695,033 S * 12/2013 Salzberger D6/356
D696,524 S * 12/2013 Ersan D6/356

D702,623 S * 4/2014 Salzberger D6/356
D767,293 S * 9/2016 Hasegawa D6/356
D790,239 S * 6/2017 Goode D6/356
D856,692 S * 8/2019 Veneruso D6/356
2004/0232283 A1* 11/2004 Ferry B64D 11/064
244/118.6

* cited by examiner

Primary Examiner — Mimoso De

(74) *Attorney, Agent, or Firm* — Greer, Burns & Crain,
Ltd.

(57) **CLAIM**

The ornamental design for an aircraft seat, as shown and described.

DESCRIPTION

FIG. 1 is a rear elevational view of an aircraft seat showing our new design;
FIG. 2 is a right side elevational view of an aircraft seat showing our new design.
FIG. 3 is a front elevational view of an aircraft seat showing our new design.
FIG. 4 is a left side elevational view of an aircraft seat showing our new design.
FIG. 5 is front perspective view of an aircraft seat showing our new design.
FIG. 6 is a top plan view of an aircraft seat showing our new design.
FIG. 7 is a front perspective view of an aircraft seat showing our new design with a bench extension extended.
FIG. 8 is a top plan view of an aircraft seat showing our new design with a bench extension extended.
FIG. 9 is a left elevational view of an aircraft seat showing our new design with a bench extension extended; and,
FIG. 10 is a front elevational view of an aircraft seat showing our new design with a bench extension extended.
The broken lines in the FIGURES represent portions of the aircraft seat that form no part of the claimed design.

1 Claim, 10 Drawing Sheets

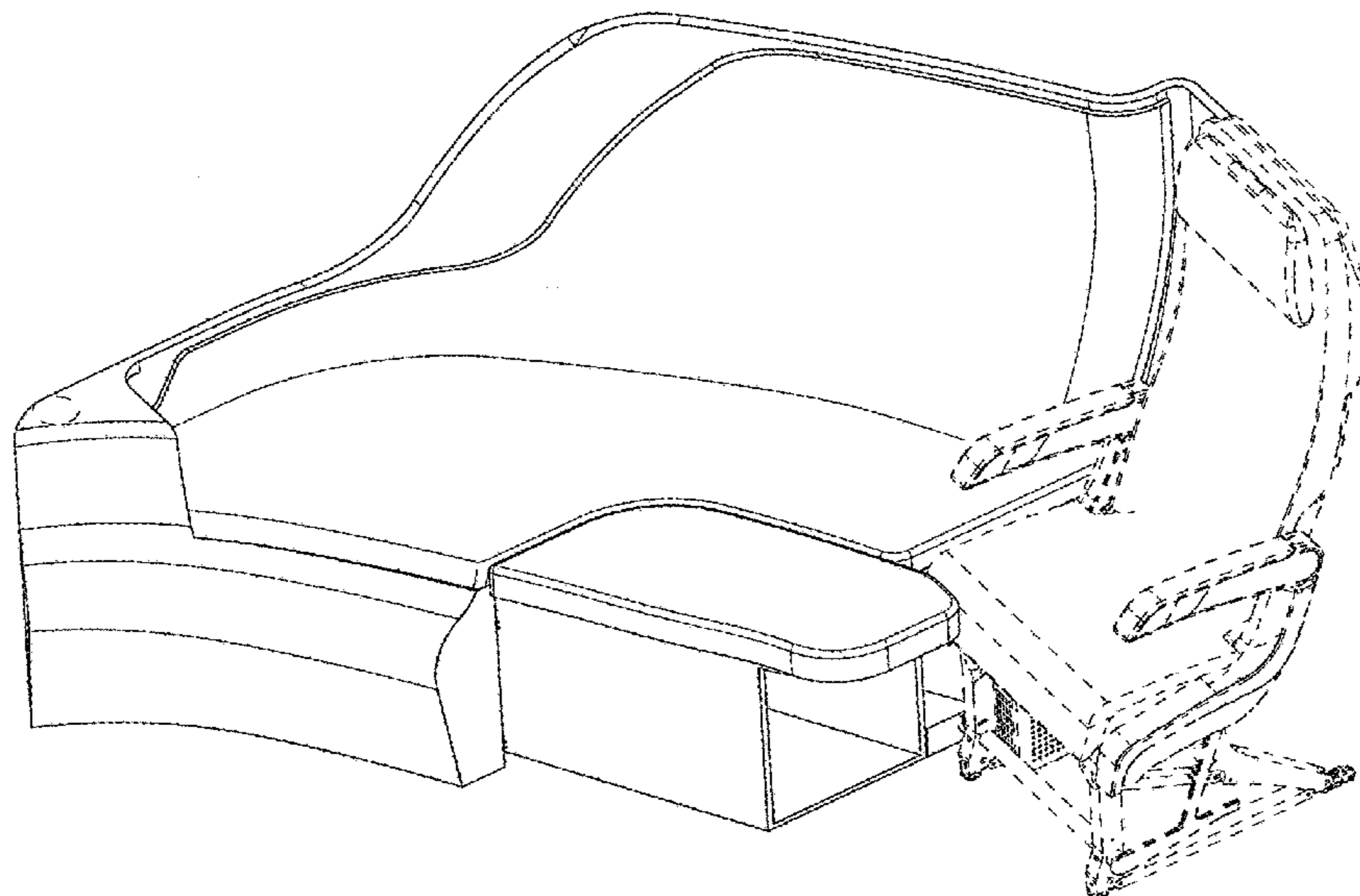

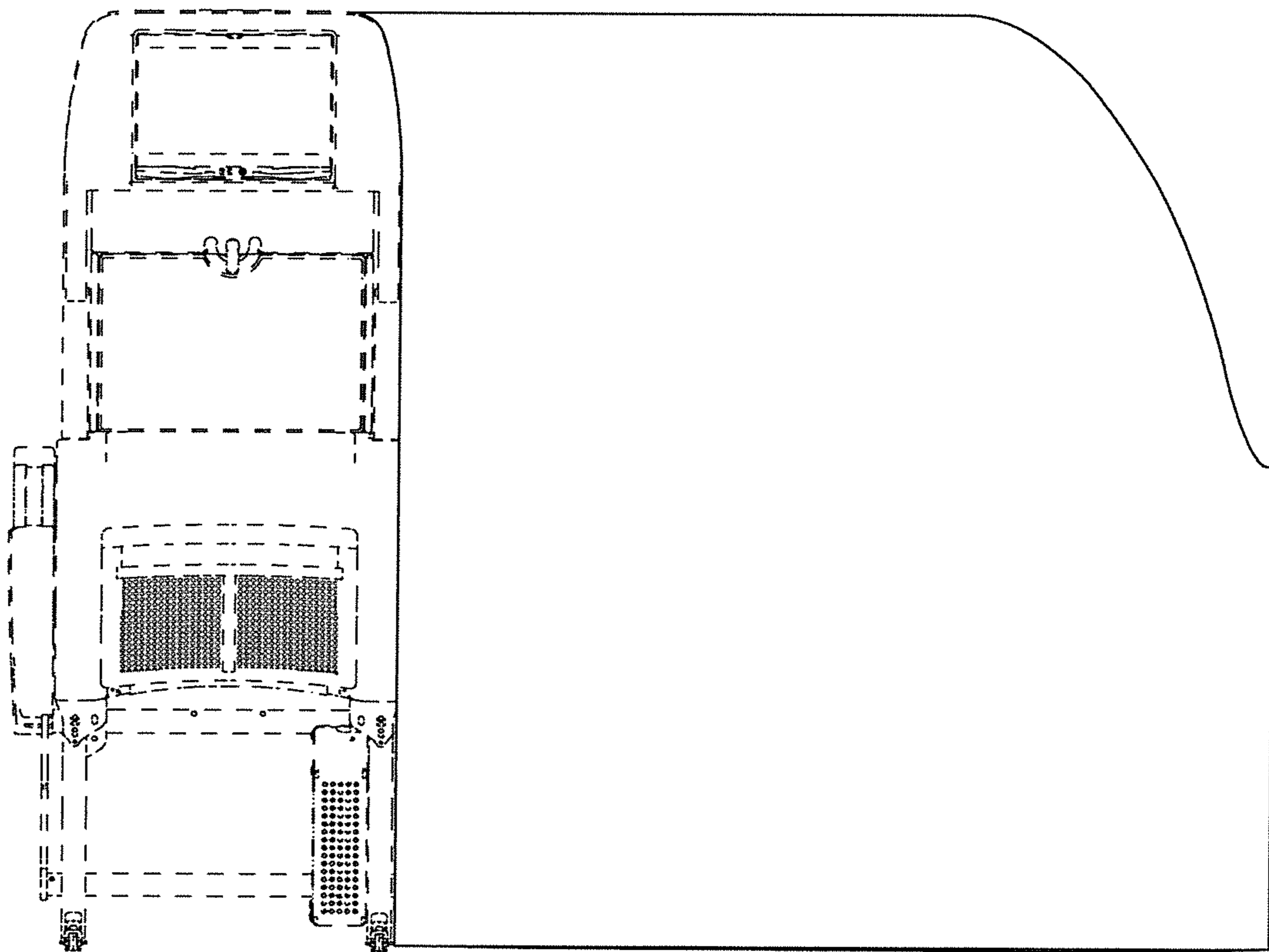

FIGURE 1

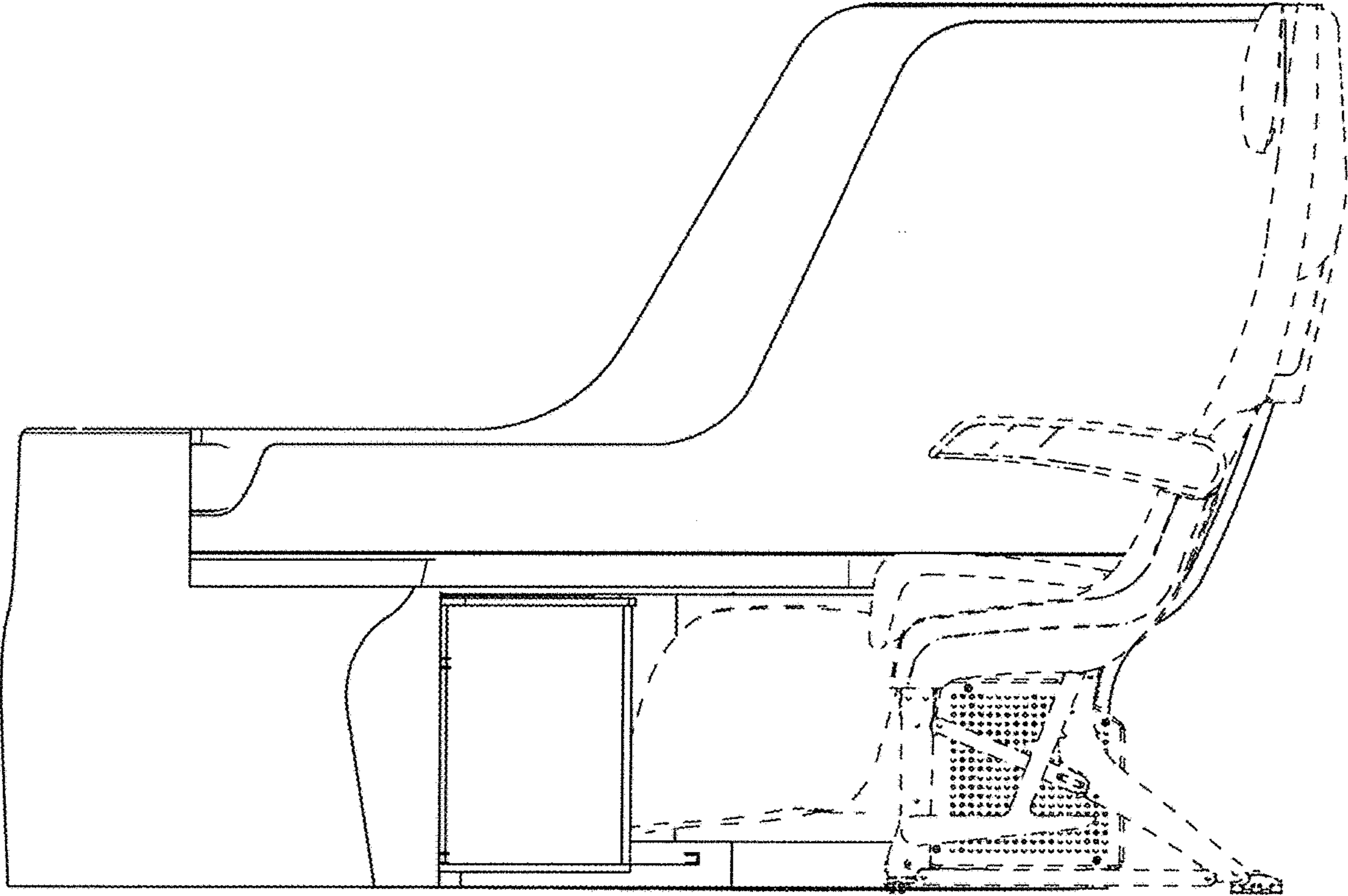

FIGURE 2

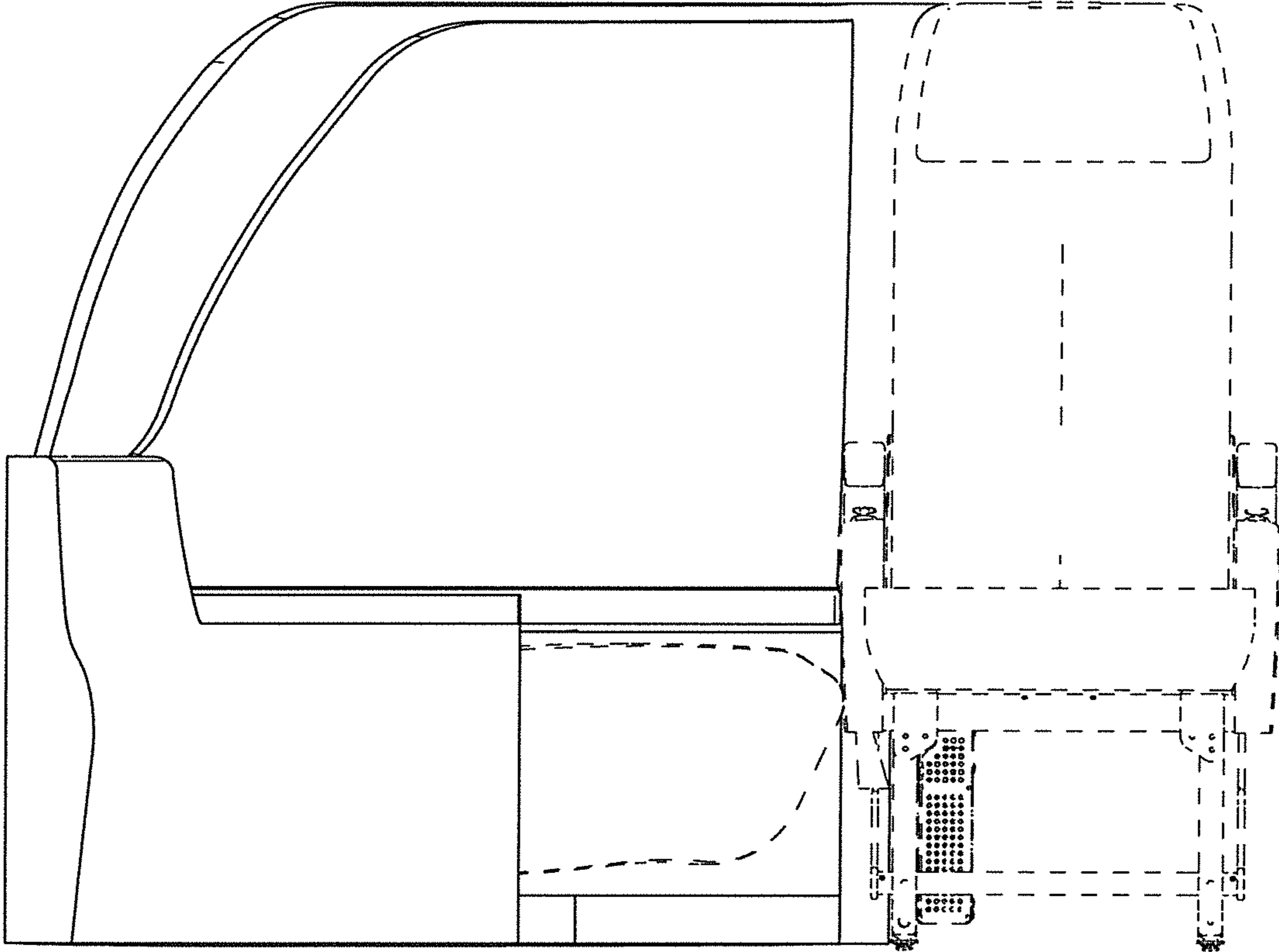

FIGURE 3

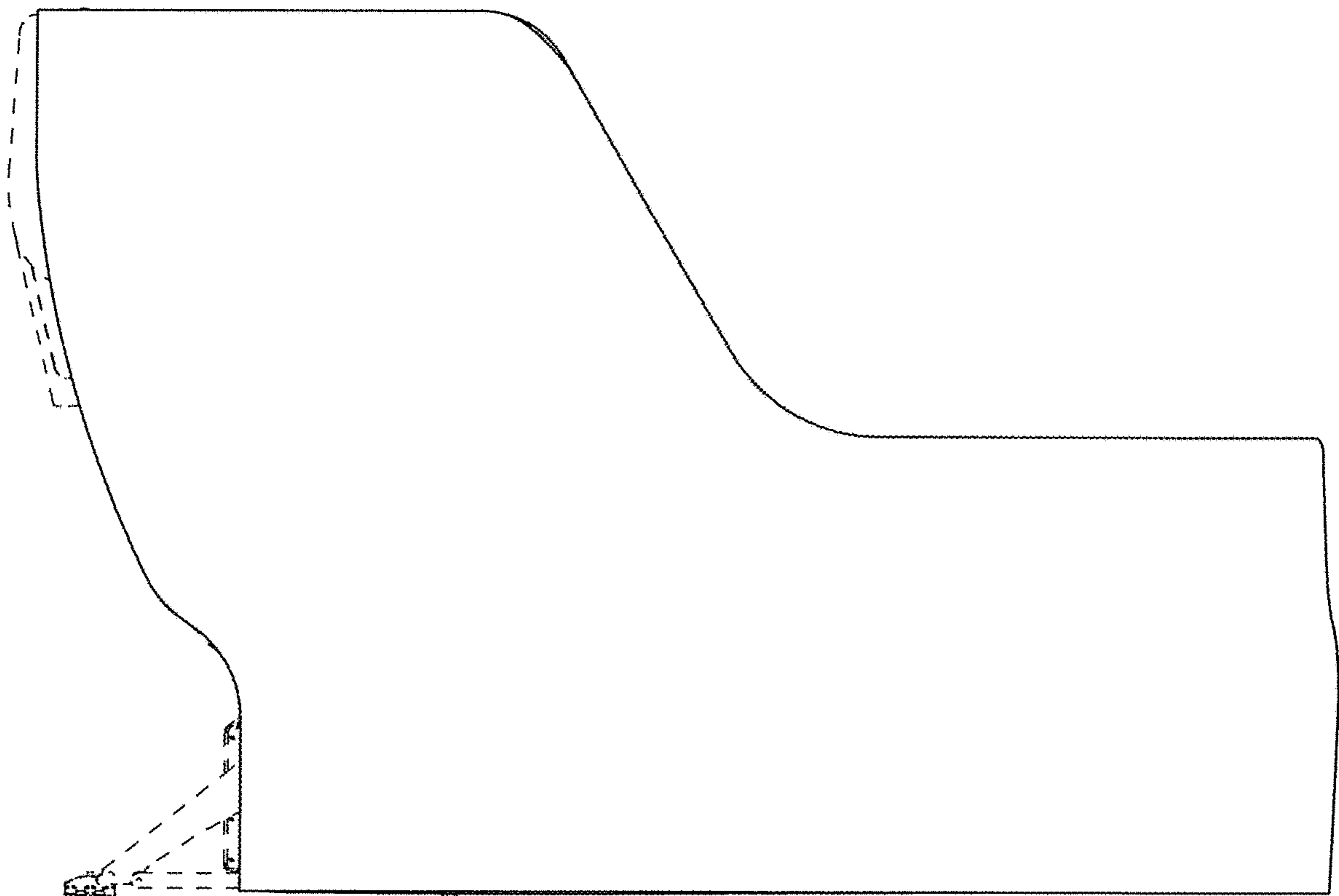

FIGURE 4

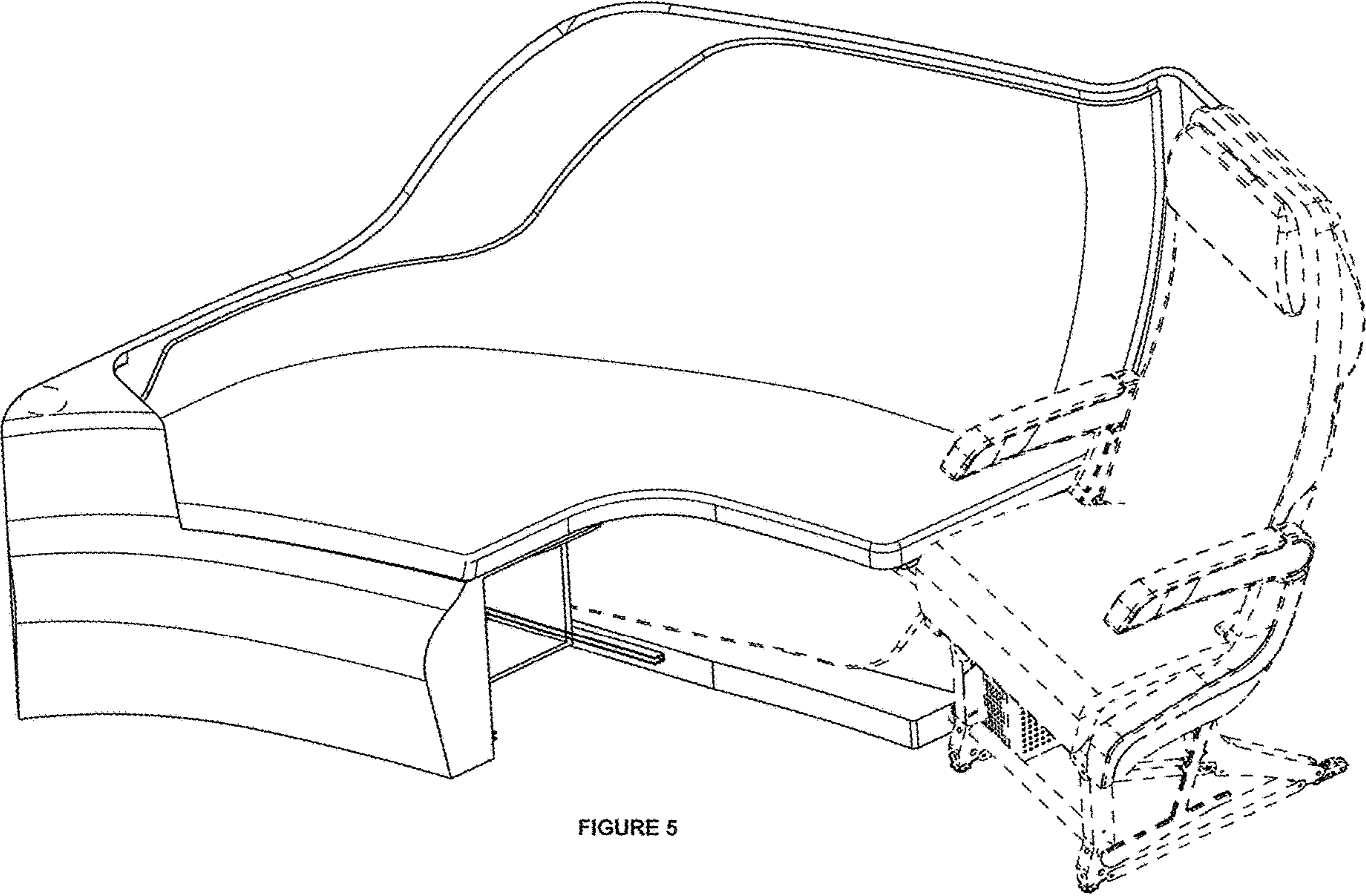

FIGURE 5

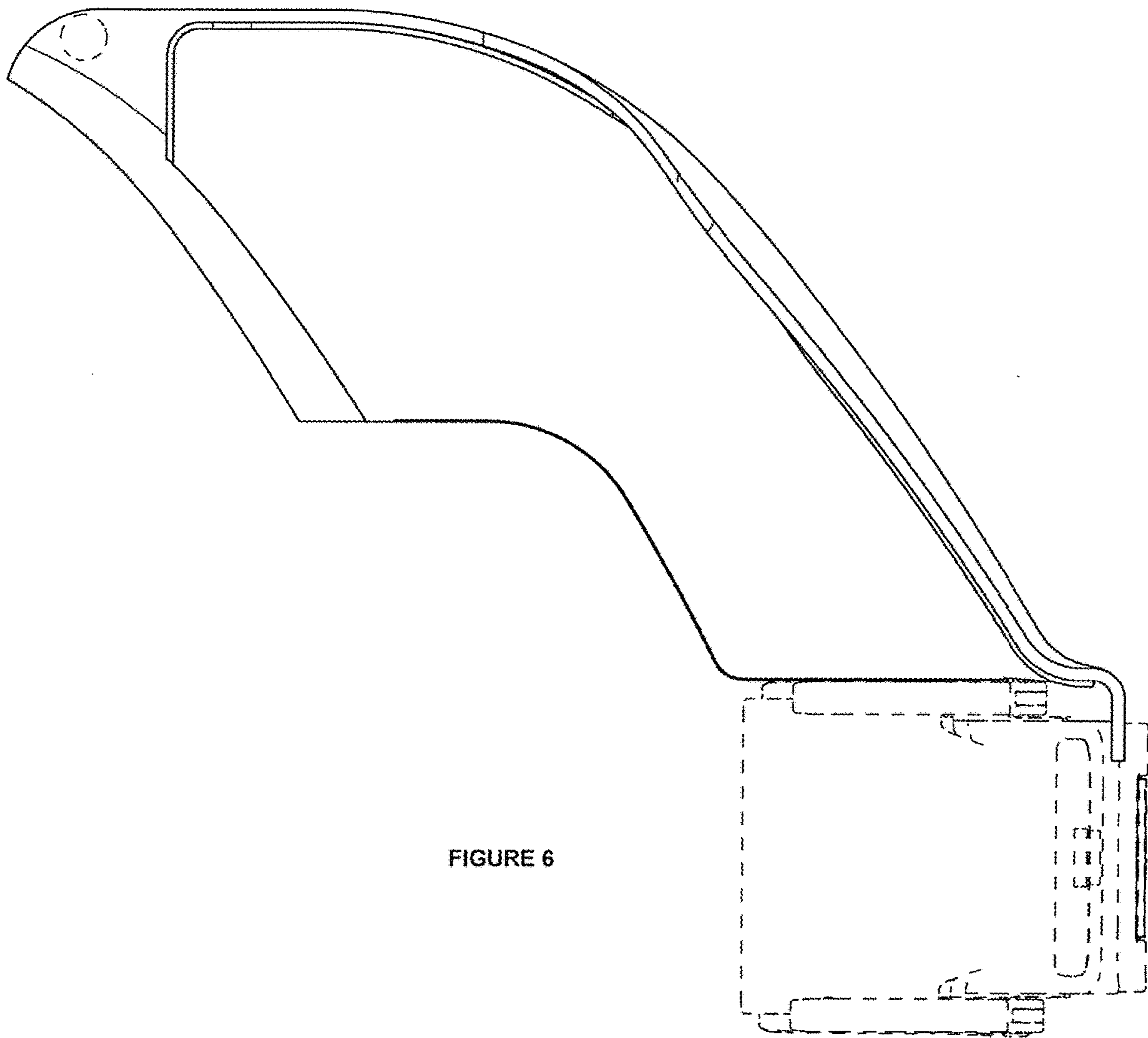

FIGURE 6

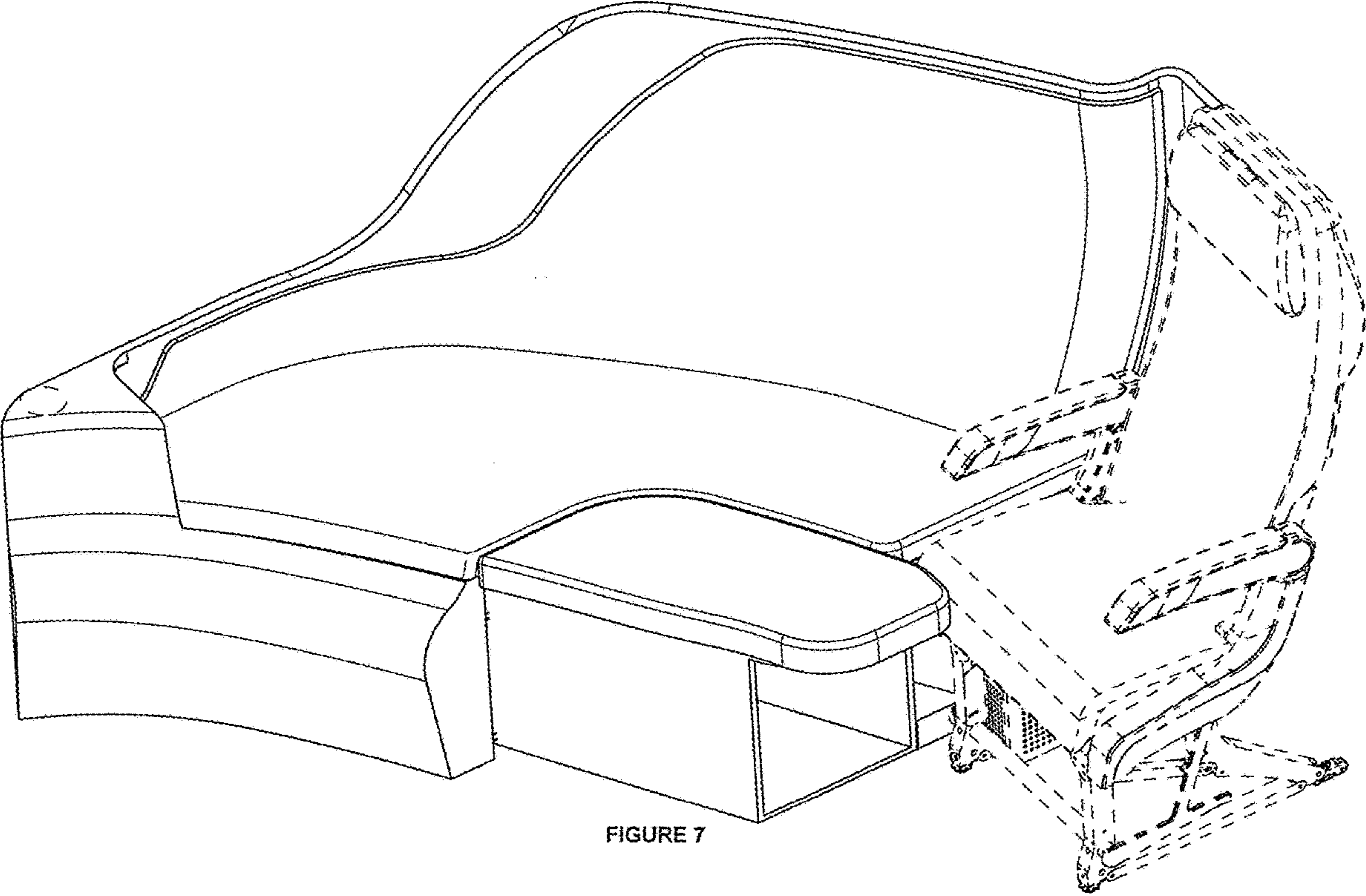

FIGURE 7

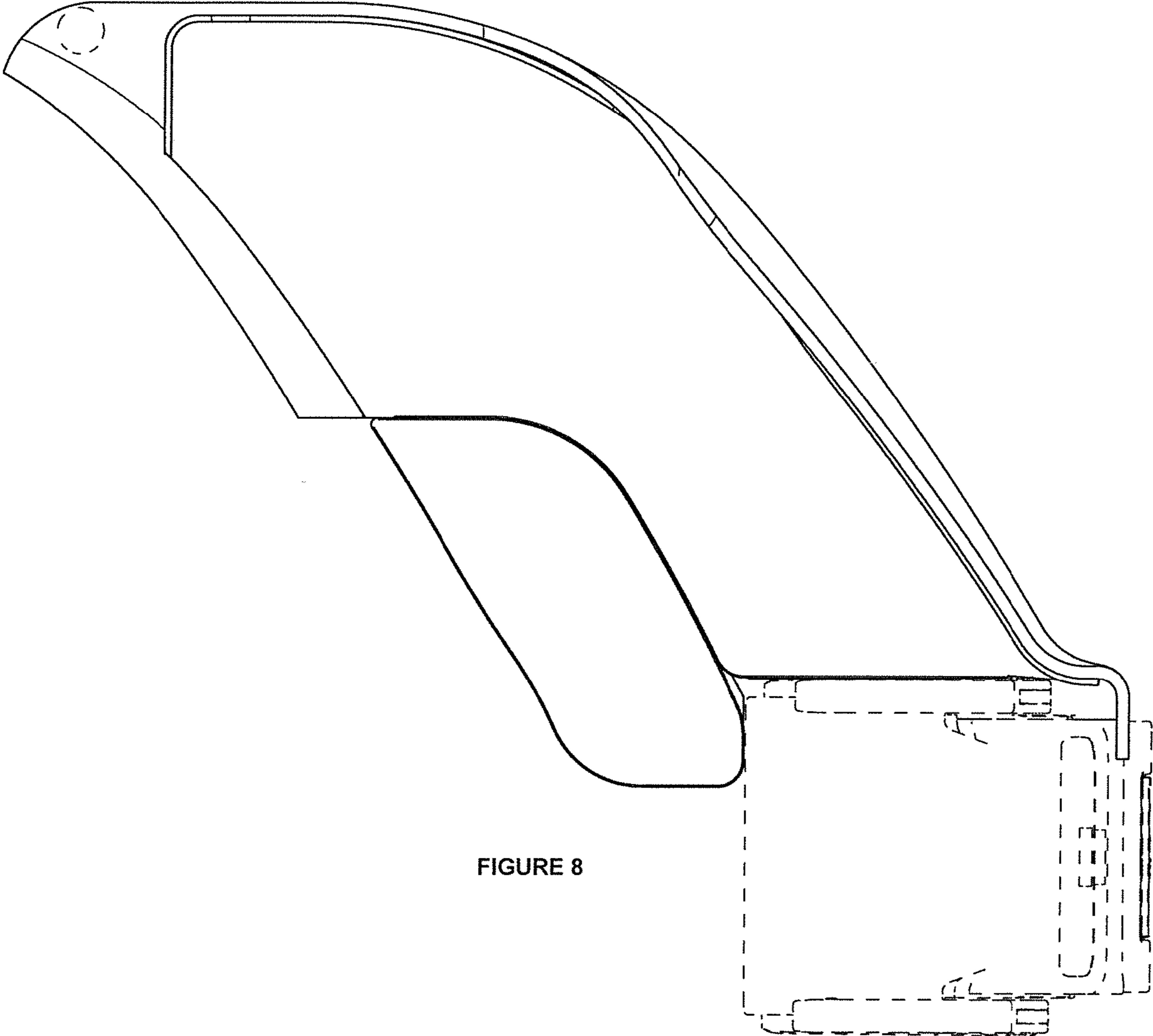

FIGURE 8

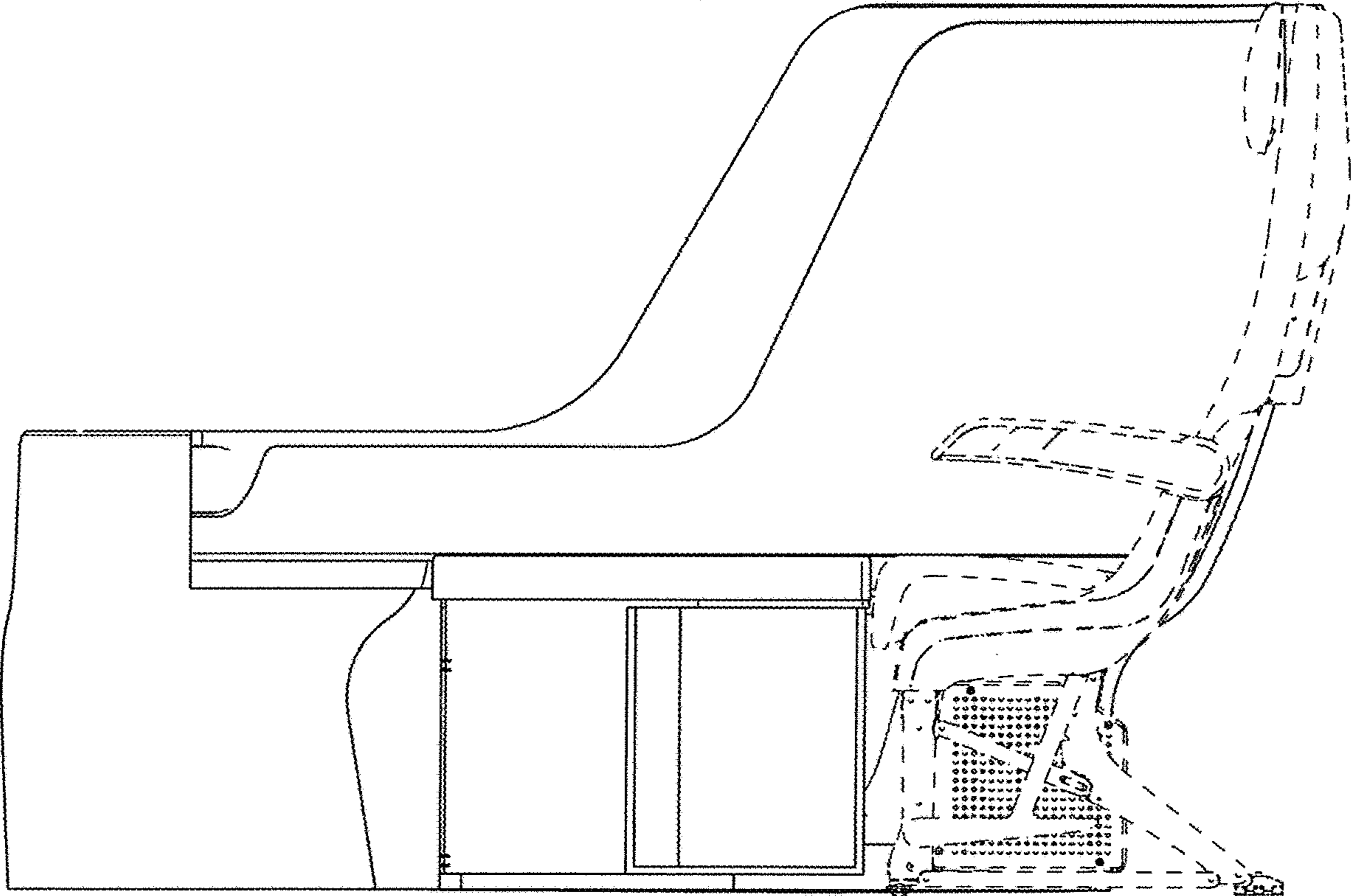

FIGURE 9

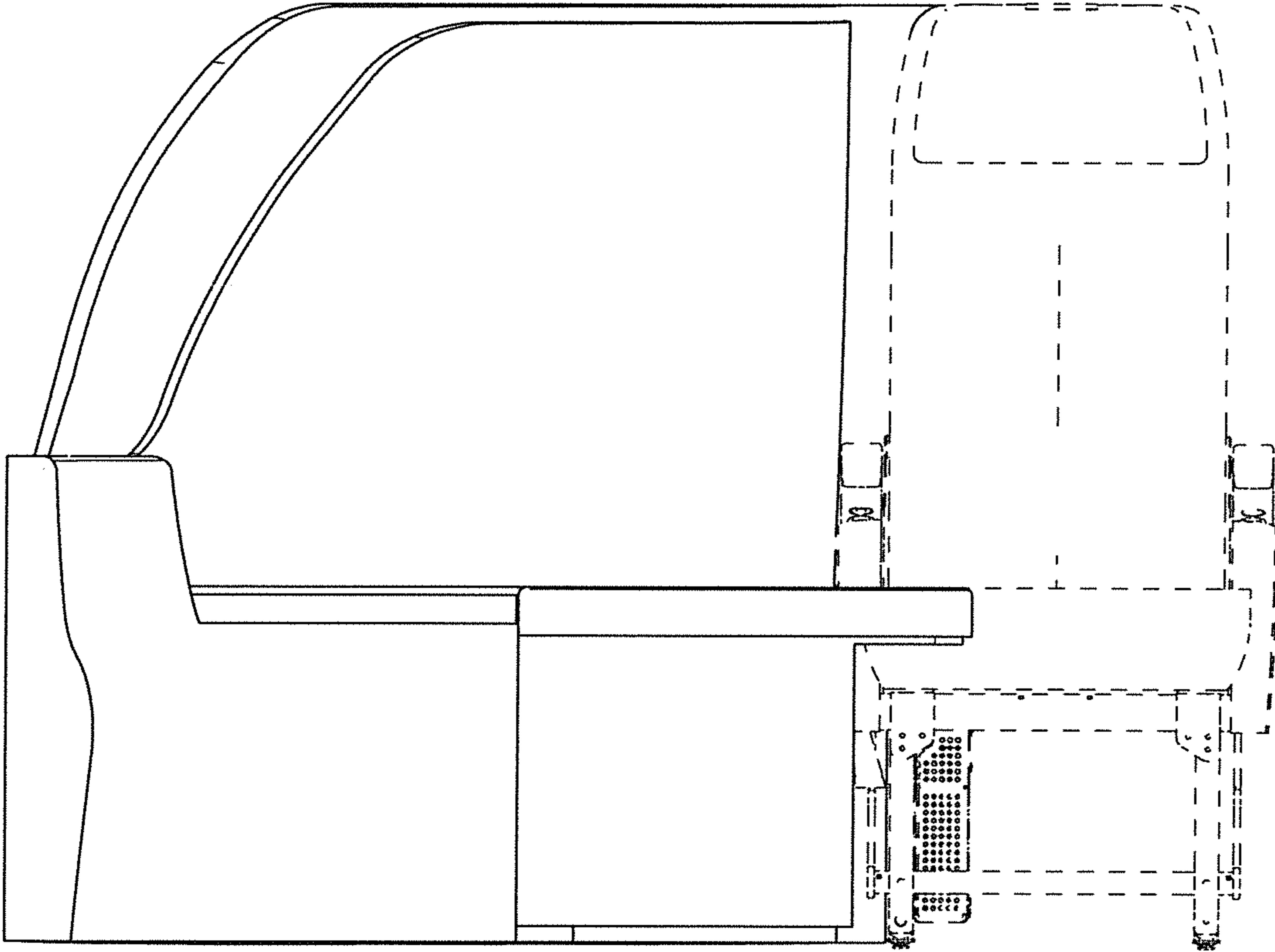

FIGURE 10