



US00D901148S

(12) **United States Design Patent** (10) **Patent No.:** **US D901,148 S**  
**Gavrieli et al.** (45) **Date of Patent:** **\*\* Nov. 10, 2020**

(54) **SINGLE-SOLE SHOE WITH PURPLE OUTPATCH SOLE** 1,525,848 A \* 2/1925 Bonaventure ..... A43B 5/12 36/113

(71) Applicant: **Gavrieli Brands LLC**, Beverly Hills, CA (US) 1,587,377 A 6/1926 Grosjean  
1,650,466 A 11/1927 Righter  
2,224,590 A 12/1940 Boivin  
2,268,777 A 1/1942 Scholl

(72) Inventors: **Kfir Gavrieli**, Beverly Hills, CA (US); **Dikla Gavrieli**, Beverly Hills, CA (US) D133,819 S \* 9/1942 Harris ..... D2/939  
D135,791 S 6/1943 Beebe  
2,323,563 A 7/1943 Nugent  
2,342,882 A 2/1944 Meltzer  
D141,871 S 7/1945 Braun  
2,383,585 A 8/1945 Bindner

(73) Assignee: **Gavrieli Brands LLC**, Beverly Hills, CA (US) D149,685 S \* 5/1948 Sandler ..... D2/935  
D150,729 S \* 8/1948 Sandler ..... D2/923  
D166,090 S \* 3/1952 Maling ..... D2/897

(\*\*) Term: **15 Years** 2,772,488 A 12/1956 Meltzer  
2,904,814 A 9/1959 Scholl  
3,148,378 A 9/1964 Tibbitts

(21) Appl. No.: **29/678,159** D200,897 S \* 4/1965 Mitchell ..... D2/919  
D220,464 S 4/1971 Hayoshi  
D247,396 S \* 3/1978 Schlerth ..... D2/939  
4,412,393 A 11/1983 Terlizzi, Jr. et al.  
D275,525 S 9/1984 Nakao  
4,674,206 A 6/1987 Lyden

(22) Filed: **Jan. 25, 2019** D295,692 S \* 5/1988 Zuidema ..... D2/950  
D300,085 S 3/1989 Ito et al.  
RE33,018 E 8/1989 Ostrander  
4,899,412 A 2/1990 Ganon  
D316,773 S 5/1991 Valle  
5,012,541 A 5/1991 Ganon  
D339,669 S \* 9/1993 Miller ..... D2/919  
5,282,326 A 2/1994 Schroer, Jr. et al.  
5,421,050 A 6/1995 Laganas  
5,699,629 A 12/1997 Munschy  
5,746,014 A 5/1998 Tanemoto  
D420,785 S 2/2000 Perez  
6,055,745 A 5/2000 Endoh  
6,076,284 A 6/2000 Terlizzi  
6,189,239 B1 2/2001 Gasparovic et al.  
6,338,207 B1 1/2002 Chang  
D457,292 S \* 5/2002 Sessa ..... D2/949  
D461,947 S 8/2002 Merceron  
6,588,124 B2 6/2003 Morrone  
D476,798 S 7/2003 Reynolds et al.  
D498,041 S 11/2004 McClaskie  
D500,191 S \* 12/2004 Belley ..... D2/969  
D501,706 S 2/2005 McClaskie  
6,857,203 B2 2/2005 Minden  
6,895,693 B2 5/2005 Baruck  
6,978,557 B2 12/2005 Lee  
7,032,327 B1 4/2006 Tartaglia et al.  
7,036,244 B1 5/2006 Finch  
D527,513 S 9/2006 Della Valle

**Related U.S. Application Data**

(63) Continuation of application No. 29/578,900, filed on Sep. 26, 2016, now Pat. No. Des. 843,093, which is a continuation of application No. 29/507,410, filed on Oct. 27, 2014, now abandoned.

(51) **LOC (12) Cl.** ..... **02-04**

(52) **U.S. Cl.**  
USPC ..... **D2/950**

(58) **Field of Classification Search**  
USPC ..... D2/896, 900, 919-921, 925-942, 947, D2/950, 969, 971  
CPC ..... A43B 21/00; A43B 21/02; A43B 21/06; A43B 9/14; A43B 1/0045; A43B 13/10; A43B 13/12; A43B 23/06; A43B 23/07; A43B 1/0036; A43B 5/12  
See application file for complete search history.

(56) **References Cited**

**U.S. PATENT DOCUMENTS**

249,086 A 11/1881 Pienovi  
773,850 A 11/1904 Cooper et al.  
830,941 A 9/1906 Walden  
1,208,209 A 12/1916 Prince  
1,214,666 A 2/1917 Ford  
1,519,009 A 12/1924 Reina

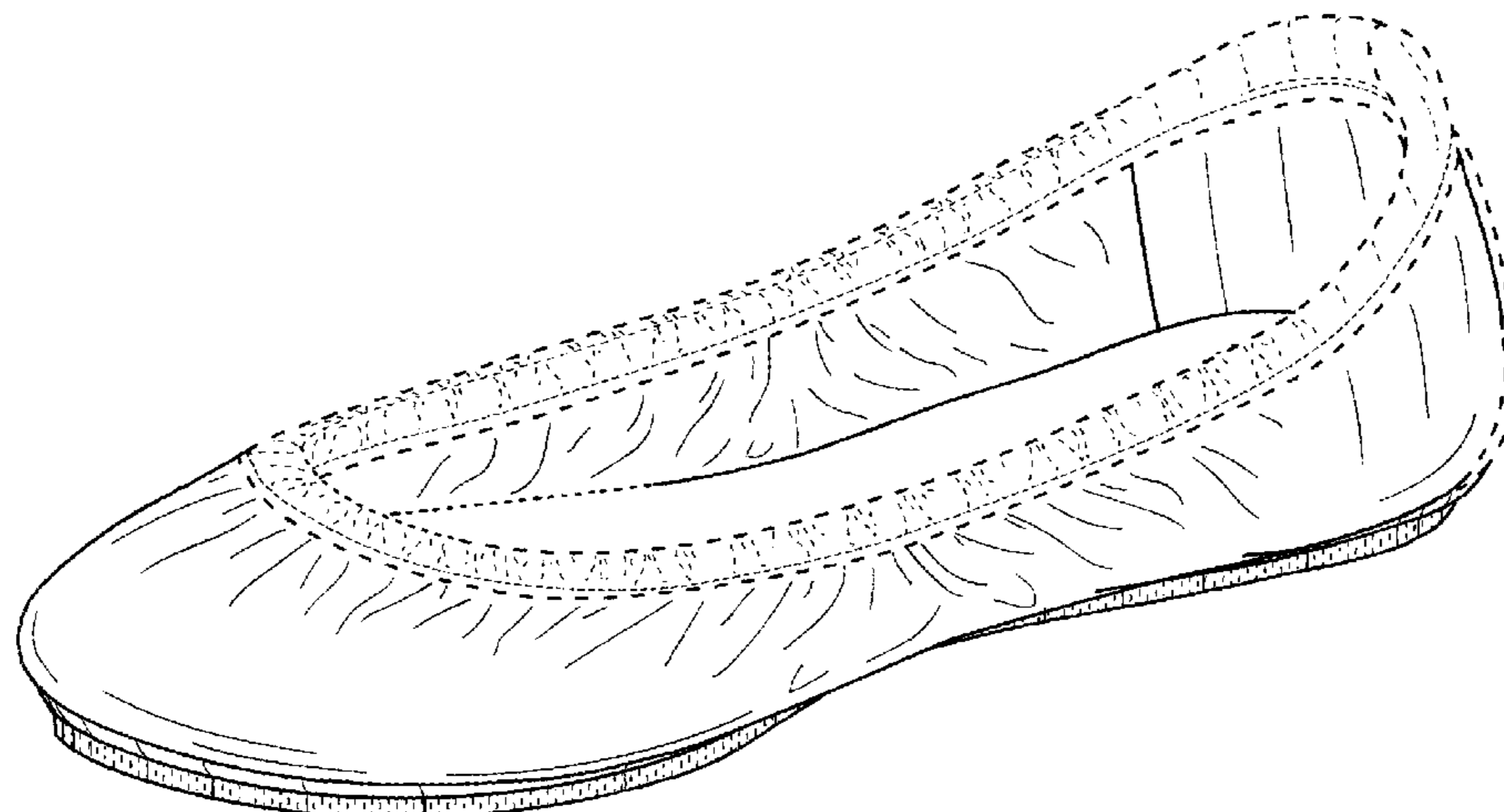

# US D901,148 S

Page 2

D529,513 S *	10/2006	Aketa	.....	D15/5
D531,790 S	11/2006	Wurzburg		
D534,341 S *	1/2007	Choi	.....	D2/896
D542,513 S	5/2007	Amado et al.		
D556,990 S	12/2007	Cabados		
7,337,558 B2	3/2008	Terlizzi et al.		
D567,485 S	4/2008	James		
D570,488 S	6/2008	Kirksey et al.		
D571,084 S	6/2008	Comeau		
D571,548 S	6/2008	Seamans		
D571,989 S	7/2008	Siegal		
D580,640 S	11/2008	Wurzburg		
D582,638 S	12/2008	Ringholz		
7,496,982 B2	3/2009	Clark et al.		
7,506,459 B2	3/2009	Grisoni et al.		
D591,031 S	4/2009	Cofinco		
D593,295 S *	6/2009	Belley	.....	D2/969
D593,297 S *	6/2009	Belley	.....	D2/969
D593,307 S *	6/2009	Belley	.....	D2/269
D599,093 S *	9/2009	Issler	.....	D2/925
D604,030 S	11/2009	Wilson		
D607,194 S	1/2010	Zagula		
D610,332 S	2/2010	Raichle		
D610,785 S	3/2010	Smith		
D612,140 S	3/2010	Moon		
D612,141 S	3/2010	Moon		
7,694,435 B1	4/2010	Kiser et al.		
D615,737 S	5/2010	Feller		
7,735,244 B1	6/2010	Ameche		
7,743,530 B2	6/2010	Truelson		
D618,891 S	7/2010	McClaskie		
7,757,408 B2	7/2010	McClaskie		
D630,829 S	1/2011	Weisner		
D632,881 S	2/2011	Rosenberg		
7,926,203 B2	4/2011	Wilkenfeld		
7,966,747 B2	6/2011	Wilkenfeld et al.		
D640,861 S	7/2011	Wilkenfeld		
8,020,320 B2	9/2011	Gillespie		
8,127,468 B2	3/2012	Morgan		
D657,543 S	4/2012	Bove		
D659,960 S	5/2012	Bizzo		
8,230,619 B2	7/2012	Salvatelli		
D664,755 S	8/2012	Gavrieli et al.		
D665,157 S	8/2012	Wu		
8,240,067 B2	8/2012	Sussmann		
8,245,420 B2	8/2012	Wilson		
D668,027 S	10/2012	Millieret		
D668,438 S	10/2012	Millieret		
D668,847 S *	10/2012	Gavrieli	.....	D2/925
D668,848 S *	10/2012	Gavrieli	.....	D2/925
D668,849 S	10/2012	Pozzi		
D668,850 S	10/2012	Pozzi		
D672,542 S	12/2012	Gray et al.		
D676,634 S *	2/2013	Gavrieli	.....	D2/925
D681,927 S *	5/2013	Gavrieli	.....	D2/925
D681,928 S *	5/2013	Gavrieli	.....	D2/925
D681,929 S *	5/2013	Gavrieli	.....	D2/925
D683,936 S *	6/2013	Gavrieli	.....	D2/925
8,468,723 B2	6/2013	Malka-Harari		
D686,812 S	7/2013	Gavrieli et al.		
8,510,975 B2	8/2013	Krikelis		
D688,853 S *	9/2013	Gavrieli	.....	D2/925
D688,854 S *	9/2013	Gavrieli	.....	D2/925
D688,855 S *	9/2013	Gavrieli	.....	D2/925
D689,270 S *	9/2013	Gavrieli	.....	D2/925
D689,271 S *	9/2013	Gavrieli	.....	D2/925
D689,272 S *	9/2013	Gavrieli	.....	D2/925
D690,914 S *	10/2013	Gavrieli	.....	D2/925
D690,915 S *	10/2013	Gavrieli	.....	D2/925
D696,500 S	12/2013	Hunt		
D699,424 S	2/2014	Hamm		
8,661,714 B2	3/2014	Sussmann		
8,745,893 B2	6/2014	Gavrieli et al.		
8,973,287 B2	3/2015	Shibata		
2002/0078591 A1	6/2002	Morrone		
2002/0129519 A1	9/2002	Cahan		
2003/0070319 A1	4/2003	Minden		
2003/0121176 A1	7/2003	Baruck		
2004/0025377 A1	2/2004	Brannon		

2005/0022421 A1	2/2005	Bruckner
2005/0115115 A1	6/2005	Lacey
2005/0217148 A1	10/2005	Connolly et al.
2005/0262734 A1	12/2005	Cheng
2006/0086005 A1	4/2006	Yerian
2006/0156576 A1	7/2006	Sloan
2007/0074424 A1	4/2007	Lin
2007/0204482 A1	9/2007	Gibson-Collinson
2007/0204483 A1	9/2007	Kirsch et al.
2008/0052964 A1	3/2008	Taylor
2008/0086912 A1	4/2008	Wilkenfeld
2008/0110059 A1	5/2008	Kuramoto et al.
2009/0019732 A1	1/2009	Sussmann
2009/0193685 A1	8/2009	Wilson
2009/0205222 A1	8/2009	Mclinden
2009/0272009 A1	11/2009	Weisner et al.
2010/0011625 A1	1/2010	Percival
2010/0018080 A1	1/2010	Smith
2010/0050469 A1	3/2010	Chen
2010/0095557 A1	4/2010	Jarvis
2010/0115793 A1	5/2010	Kraisosky
2010/0122475 A1	5/2010	Purrington
2010/0146822 A1	6/2010	MacGregor
2010/0212186 A1	8/2010	Cheng
2010/0275462 A1	11/2010	Pucci
2010/0281713 A1	11/2010	Pantazes
2015/0089843 A1	4/2015	Gavrieli

## FOREIGN PATENT DOCUMENTS

DE	20	2006	00023	U1	5/2007
GB			2443937	A	5/2008
GB		2	446	205	A 8/2008
TW			D119165		10/2007

## OTHER PUBLICATIONS

Examination Report for AU 341324, 3 pgs., dated Oct. 24, 2012.  
 Letter from TMI and Associates with Office Action, 2 pgs, dated Sep. 19, 2012 <http://www.payless.com/store/?&TLC=Womens&SLC=WomensNewArrivals&BLC=WomensNewArrivalsNewArrivals&With+Regular&ItemCode=60131&LotNumber=062642&Type=Adult&Popularity=637&Descriptvein>.  
 Taiwanese Office Action for TW 101300726, 10 pgs., dated Sep. 6, 2012.  
 “The Love List, Tieks by Gavrieli—Foldable Ballet Flats,” <http://thelovelist-carly.blogspot.com.au/2010/09/tieks-by-gavrieli-foldable-ballet.html>, 2 pgs., Sep. 12, 2010.  
 “Tieks by Gavrieli,” <http://tieks.com>, 1 pg., retrieved Mar. 13, 2013 from URL.  
 “Try It Mummy!, Tieks by Gavrieli,” <http://tryitmummy.blogspot.com.au/2010/12/tieks-by-gavrieli.html>, 3 pgs., Dec. 9, 2010.  
 “Wearability—Real People Style, What came first, the City Flat or the Tieks,” <http://wearability.posterous.com/what-came-first-thy-city-flat-or-the-tieks>, 2 pgs., Aug. 29, 2010.  
 “The Ballet Flat . . . Reinvented; Ballet Flats . . . with a Bonus; Step Into Tieks; Going Places? Take Tieks,” <http://web.archive.org/web/2010052004346/http://www.tieks.com/>; 4 pgs., May 24, 2010.  
 “Tieks—Comfortable designer flats you can fit in your purse and wear all day, every day,” <http://web.archive.org/web/20110731151555/http://tieks.com/>; 6 pgs., Jul. 31, 2011.  
 “58th Annual Emmy Awards,” [http://spoonsforksandfashion.blogspot.com/2006\\_08\\_01\\_archive.html](http://spoonsforksandfashion.blogspot.com/2006_08_01_archive.html), depicting Nine West flats, 2 pgs., Aug. 1, 2006.  
 Pictures of Nine West flats sold in 2006, 3 pgs.  
 “I Love a Good Ballet Flat!,” <http://dressupfiles.com/i-love-a-good-ballet-flat>, depicting Sue London flats, 3 pgs., Sep. 3, 2010.  
 Pictures of Sue London flats sold in 2010, 2 pgs.  
 “Miss Cathie Reviews: The Yosi Samra Foldable Ballet Flat . . .,” <http://www.misscathie.com/2010/01/miss-cathie-reviews-the-yosi-samra-foldable-ballet-flat/>, depicting Yosi Samra flats, 9 pgs., Jan. 2010.  
 Pictures of Yosi Samra flats sold in 2010, 2 pgs.

- “Goodbye two thousand ten,” [http://emmajoyrussell.blogspot.com/2010\\_12\\_01\\_archive.html](http://emmajoyrussell.blogspot.com/2010_12_01_archive.html), depicting Gap, flats 39 pgs., Dec. 1, 2010.
- Pictures of Gap flats available for sale in 2010, 9 pgs.
- “Our newest design of folding flats—Pink,” <http://fitinclouds.wordpress.com/2010/05/16/our-newest-design-of-folding-flats-pink/>, depicting Fit in Clouds flats, 1 pg., May 16, 2010.
- “Fit in Clouds Satin Folding Shoes,” <http://www.goodhousekeeping.com/product-reviews/clothing/best-ballet-flats/fit-in-clouds-satin-foldable-ballet-flats>, depicting Fit in Clouds flats, 2 pg., Aug. 2013.
- Pictures of Fit in Clouds flats available for sale in 2011, 4 pgs.
- “Shoes for Standing,” <https://truthinshoes.wordpress.com/2008/07/>, depicting Sam & Libby flats, 2 pgs., Jul. 31, 2008.
- “Target Designer Collaboration: Announcing Sam & Libby Shoes for Target,” <http://www.therecessionista.com/2012/11/ftarget-designer-collaboration-announcing-sam-libby-shoes-for-target.html>, depicting Sam & Libby flats, 1 pg., Nov. 26, 2012.
- Pictures of Sam & Libby flats available for purchase in 2011, 5 pgs.
- “Save your soles with Citisoles ballet flats,” <http://glamazondiaries.com/2009/07/save-your-soles-with-citisoles-ballet-flats>, depicting Citisoles flats, 3 pgs., Jul. 2009.
- Pictures of Citisoles flats available for purchase in 2009, 3 pgs.
- “#16 Corso Como Delicious Pumps Review and Giveaway!,” <http://www.mommatoldmeblog.com/2011/01/16-corso-como-delicious-pumps-review.html>, depicting Corso Como flats, 8 pgs., Jan. 16, 2011.
- Pictures of Corso Como flats available for sale in 2011, 3 pgs.
- “jil-sander-navy-lead-ballet-flats-product . . . ,” [www.ebay.com](http://www.ebay.com), depicting Jil Sander flats, 4 pgs., Nov. 2013.
- Pictures of Jil Sander flats available for sale in 2011, 3 pgs.
- “Spare Soles: Shoes That Roll-up & Fold-up,” <http://herpackinglist.com/2011/01/spare-soles-shoes/>, depicting Spare Soles flats, 2 pgs., Jan. 2011.
- Pictures of Spare Soles flats available for sale in 2011, 5 pgs.
- Pictures of Roll-Upz by Spare Soles flats available for sale in 2011, 6 pgs.
- “The Cutest Blog, Preppy 50 and Loving Lilly, Ballet Flat Delight,” <http://preppy50andlovinglilly.blogspot.com/2011/02/ballet-flat-delight.html>, depicting Henri Bendel flats, 1 pg., Feb. 19, 2011.
- Pictures of Henri Bendel flats available for sale in 2011, 4 pgs.
- “Mumsnet by parents for parents,” [http://www.mumsnet.com/Talk/style\\_and\\_beauty/a1612000-Anyone-tried-Redfoot-Flatmates-foldable-ballet-pumps](http://www.mumsnet.com/Talk/style_and_beauty/a1612000-Anyone-tried-Redfoot-Flatmates-foldable-ballet-pumps), depicting Redfoot Flatmates flats, 1 pg, Nov. 14, 2012.
- Pictures of Redfoot Flatmates flats available for sale in 2011, 6 pgs.
- “Amazon.com: Customer Reviews: Bloch London Women’s Lux Ballet Flat,” <http://www.amazon.com/Bloch-London-Womens-Ballet-Flat/product-reviews/B004LWP7W>, depicting Bloch London flats, 4 pgs., Dec. 11, 2011.
- Pictures of Bloch London flats offered for sale in 2011, 11 pgs.
- “h&m foldable leopard print flat,” <https://8485shops.wordpress.com/2011/06/16/flats-for-7-bucks/shoe1/>, depicting h&m flats, 2 pgs., Jun. 16, 2011.
- Pictures of h&m foldable flats offered for sale in 2011, 4 pgs.
- “Seekyt—Juicy Couture Ballet Flats—Are They Worth The Money?,” <http://seekyt.com/juicy-couture-ballet-flats-are-they-worth-the-money/>, 2 pgs., Jun. 3, 2011.
- Pictures of Juicy Couture flats offered for sale in 2011, 3 pgs.
- “Purse Flats,” <http://purseflats.wordpress.com>, depicting Purse Flats by Erica Wilson, 3 pgs., Jul. 12, 2012.
- Pictures of Purse Flats by Erica Wilson offered for sale in 2011, 6 pgs.
- “Tieks by Gavrieli—Comfortable, designer flats you can fit in your purse and wear all day . . . ,” <http://web.archive.org/web/20110202210649/http://www.tieks.com/>, 8 pgs., Feb. 2, 2011.
- “Carolina M. M. Gonzalez > Tieks by Gavrieli,” [http://m2.facebook.com/Tieks?v=timeline&filter=2&timecutoff=1406427986&page=17&sectionLoadingID=m\\_timeline\\_loading\\_div\\_1293868799\\_1262332800\\_8\\_17&timeend=1293868799&timestart=1262332800&tm=AQDOvqhWQPN\\_Nbwm&refid=17](http://m2.facebook.com/Tieks?v=timeline&filter=2&timecutoff=1406427986&page=17&sectionLoadingID=m_timeline_loading_div_1293868799_1262332800_8_17&timeend=1293868799&timestart=1262332800&tm=AQDOvqhWQPN_Nbwm&refid=17), 1 pg. Jan. 26, 2010.
- “The Shoes Oprah Would Wear to Work (if She Had to Walk),” <http://www.inc.com/30under30/christina-desmarais/kfir-gavrieli-and-elram-gavrieli-founders-of-tieks.html>, 2 pgs., Jul. 2, 2012.
- “Tieks by Gavrieli,” [http://m2.facebook.com/Tieks?v=timeline&filter=2&timecutoff=1406427986&page=14&sectionLoadingID=m\\_timeline\\_loading\\_div\\_1293868799\\_1262332800\\_8\\_14&timeend=1293868799&timestart=1262332800&tm=AQDOvqWQPN\\_Nbwm&refid=17](http://m2.facebook.com/Tieks?v=timeline&filter=2&timecutoff=1406427986&page=14&sectionLoadingID=m_timeline_loading_div_1293868799_1262332800_8_14&timeend=1293868799&timestart=1262332800&tm=AQDOvqWQPN_Nbwm&refid=17), 4 pgs., Jan. 26, 2010.
- “Mighty Life List, Sensible Shoes,” <http://mightygirl.com/2010/08/24/sensible-shoes/>, 11 pgs., Aug. 24, 2010.
- “Find! Tieks: Fab & sexy flats for fall,” <http://thefabmom.com/2013/08/29/find-tieks-fab-sexy-flats-for-fall/>, 3 pgs. Aug. 29, 2013.
- “Step into Tieks,” <http://sliceofpink.typepad.com/blog/2010/09/tieks-1.html>, 5 pgs., Sep. 22, 2010.
- “In Need of Flat-Soled Shoes,” <http://www.kellywickham.com/mochamomma/2010/10/4/in-need-of-flat-soled-shoes.html>, 4 pgs., Oct. 3, 2010.
- “Say Hello to the Flat Shoes You Need for Fall . . . All 88 of Them!”, Picture of Adam Tucker Shoe/Slipper, <https://www.facebook.com/search/top/?q=adam%20shoes%20slipper>, last accessed Oct. 28, 2016, dated Oct. 1, 2013, 1 page.
- Picture of Adam Tucker Rainbow Shoes, <https://www.facebook.com/search/top/?q=adam%20shoes%20rainbow>, last accessed Oct. 28, 2016, dated Aug. 14, 2013, 1 page.
- Third Party Submission Under 37 CFR 1.290 regarding U.S. Appl. No. 15/905,239, filed Feb. 9, 2019, 94 pages.
- Order Granting TRO (D.I. 11), *Gavrieli Brands LLC vs. Soto Massini*, Civil Action No. 1:18-cv-00462, Mar. 28, 2018, 2 pages.
- Defendants’ Opposition to Motion for Temporary Restraining Order, Civil Action No. 1:18-cv-00462-GMS, Apr. 1, 2018, 12 pages.
- Declaration of Thomas Pichler in Opposition to Tro Request, C.A. No. 1:18-cv-00462-GMS, Apr. 1, 2018, 8 pages.
- Exhibit A to Pichler Declaration ISO TRO Opposition (D.I. 13-1), C.A. No. 1:18-cv-00462-GMS, Apr. 1, 2018, 29 pages.
- Order TRO (D.I. 18), C.A. No. 1:18, Apr. 4, 2018, 3 pages.
- Defendant Soto Massini (USA) Corporation’s Answer and Counterclaims to Verified Complaint for Patent Infringement, Trade Dress Infringement, and Unfair Competition, C.A. No. 1:18-cv-00462-GMS, May 1, 2018, 26 pages.
- Defendant Soto Massini (USA) Corporation’s Answer To Amended Complaint and Amended Counterclaims, C.A. No. 1:18-cv-00462-GMS, Jun. 5, 2018, 28 pages.
- Defendant Soto Massini (USA) Corporation’s Answer To Amended Complaint and First Amended Counterclaims, C.A. No. 1:18-cv-00462-GMS, Jul. 12, 2018, 31 pages.
- Exhibit A to SACC (45-1), Case 1:18-cv-00462-GMS, 3 pages.
- Exhibit B to SACC (45-2), Case 1:18-cv-00462-GMS, 5 pages.
- Exhibit C to SACC (45-3), Case 1:18-cv-00462-GMS, 5 pages.
- Exhibit D to SACC (45-4), Case 1:18-cv-00462-GMS, 4 pages.
- Defendant Soto-USA’s Invalidity Contentions, C.A. No. 1:18-cv-00462-MN, 16 pages.
- Redacted Verdict Form (D.I. 144), Case 1:18-cv-00462-GMS, 13 pages.
- Judgement (D.I. 149), C.A. No. 18-462-MN, May 13, 2019, 3 pages.
- Gavrieli Brands, LLC, v. Soto Massini (USA) Corp., et al.*, (full) Trial Transcript, C.A. No. 18-462(MN), vol. 1, 733 pages.
- Expert Report of Caroline de Baere (Fed. R. Civ. P. 26(a)(2)(B), Case No. 18-cv-00462-MN, Mar. 1, 2019, 33 pages.
- Exhibit 23, Infringement Analysis in Light of the Alleged Prior Art, 41 pages.
- Expert Report of Lance Rake, (Fed. R. Civ. P. 26(a)(2)(B), Mar. 1, 2019, 27 pages.
- U.S. Pat. No. 1,525,848, Feb. 10, 1925, B. S. Bonaventure, 3 pages.
- Design U.S. Pat. No. 247,396, Mar. 7, 1978, William A. Schlerth, 2 pages.
- Design U.S. Pat. No. D611,693 S, Mar. 16, 2010, Barbara Schwartz, 7 pages.
- Camper Book Excerpt—Nina Right, (pp. 334-335), The Walking Society, Lars Müller Publishers, 3 pages.
- Camper History—The Shoes, Every Season We Strive to Reinvent Some Of Our Classic Concepts While Continuing to Challenge the Status Quo With New and Original Designs. We Often Find That There Is a Camper Style for Every Walk of Life, 8 pages.

Tieks by Gavrieli—Comfortable, designer flats you can fit in your purse and wear all day, every day!, Copperhead Snake Print Tieks, <https://web.archive.org/web/20101230062534/http://www.tieks.com:80/>, Dec 30, 2010, 1 page.

Tieks by Gavrieli—Comfortable, designer flats you can fit in your purse and wear all day, every day!, Merlot Lizard Print Tieks, <https://web.archive.org/web/20101230062534/http://www.tieks.com:80/>, Dec. 30, 2010, 1 page.

Tieks by Gavrieli—Comfortable, designer flats you can fit in your purse and wear all day, every day!, Slate Grey Tieks, <https://web.archive.org/web/20101230062534/http://www.tieks.com:80/>, Dec. 30, 2010, 1 page.

Tieks by Gavrieli—Comfortable, designer flats you can fit in your purse and wear all day, every day!, Camel, <https://web.archive.org/web/20101230062534/http://www.tieks.com:80/>, Dec. 30, 2010, 1 page.

Tieks by Gavrieli—Comfortable, designer flats you can fit in your purse and wear all day, every day!, Lilac, <https://web.archive.org/web/20101230062534/http://www.tieks.com:80/>, Dec. 30, 2010, 1 page.

Tieks by Gavrieli—Comfortable, designer flats you can fit in your purse and wear all day, every day!, Leopard Print, <https://web.archive.org/web/20101230062534/http://www.tieks.com:80/>, Dec. 30, 2010, 1 page.

Tieks by Gavrieli—Comfortable, designer flats you can fit in your purse and wear all day, every day!, The Tieks eGift card . . . Always the perfect fit, <https://web.archive.org/web/20101230062534/http://www.tieks.com:80/>, Dec. 30, 2010, 1 page.

Tieks by Gavrieli—Comfortable, designer flats you can fit in your purse and wear all day, every day!, Copperhead Snake Print, <https://web.archive.org/web/20110222174850/http://www.tieks.com:80/>, Feb. 22, 2011, 1 page.

Tieks by Gavrieli—Comfortable, designer flats you can fit in your purse and wear all day, every day!, Patent Tiek Blue, <https://web.archive.org/web/20110222174850/http://www.tieks.com:80/>, Feb. 22, 2011, 1 page.

Tieks by Gavrieli—Comfortable, designer flats you can fit in your purse and wear all day, every day!, Tangerine, <https://web.archive.org/web/20110222174850/http://www.tieks.com:80/>, Feb. 22, 2011, 1 page.

Tieks by Gavrieli—Fashionable Flats That Fit in Your Purse California Navy, <https://web.archive.org/web/20100516173039/http://www.tieks.com:80/california-navy.html>, May 16, 2010, 1 page.

Tieks by Gavrieli—Fashionable Flats That Fit in Your Purse Cardinal Red, <https://web.archive.org/web/20100516173045/http://www.tieks.com:80/cardinal-red.html>, May 16, 2010, 1 page.

Tieks by Gavrieli—Fashionable Flats That Fit in Your Purse Metallic Gold, <https://web.archive.org/web/20100516173106/tieks.com/metallic-gold.html>, May 16, 2010, 1 page.

Tieks by Gavrieli—Fashionable Flats That Fit in Your Purse Patent Tiek Blue, <https://web.archive.org/web/20100516173130/http://www.tieks.com:80/tiek-blue.html>, May 16, 2010, 1 page.

Tieks by Gavrieli—Fashionable Flats That Fit in Your Purse Splash Page, The Ballet Flat . . . Reinvented, <https://web.archive.org/web/20100513055818/https://tieks.com/>, May 13, 2010, 1 page.

Tieks by Gavrieli—Fashionable Flats That Fit in Your Purse Splash Page, Ballet Flats . . . with a Bonus, <https://web.archive.org/web/20100513055818/https://tieks.com/>, May 13, 2010, 1 page.

Tieks by Gavrieli—Fashionable Flats That Fit in Your Purse Splash Page, Going Places? Take Tieks. <https://web.archive.org/web/20100513055818/https://tieks.com/>, May 13, 2010, 1 page.

Tieks by Gavrieli—Fashionable Flats That Fit in Your Purse Splash Page, Step Into Tieks, <https://web.archive.org/web/20100513055816/https://tieks.com/>, May 13, 2010, 1 page.

Tieks by Gavrieli—Fashionable Flats That Fit in Your Purse True Blue, <https://web.archive.org/web/20100516173135/http://www.tieks.com:80/true-blue.html>, May 16, 2010, 1 page.

Tieks by Gavrieli—Fashionable Flats That Fit in Your Purse White Croc Print, <https://web.archive.org/web/20100516173145/http://www.tieks.com:80/white-croc-print.html>, May 16, 2010, 1 page.

Tieks by Gavrieli—Foldable Fashionable Ballet Flats, Wild Copper, Be a little wild . . . even when you're not., <https://web.archive.org/web/20100819165503/https://tieks.com/>, Aug. 19, 2010, 1 page.

Tieks by Gavrieli—Foldable Fashionable Ballet Flats, Paradise Blue, The perfect pair for day and night, <https://web.archive.org/web/20100819165503/https://tieks.com/>, Aug 19, 2010, 1 page.

Tieks by Gavrieli—Foldable Fashionable Ballet Flats, Obsidian Black, When workdays spill over into party nights., <https://web.archive.org/web/20100619165503/https://tieks.com/>, Aug. 19, 2010, 1 page.

Tieks by Gavrieli—Foldable Fashionable Ballet Flats, Fuchsia, Sweet and sultry, <https://web.archive.org/web/20100819165503/https://tieks.com/>, Aug. 19, 2010, 1 page.

Tieks by Gavrieli—Foldable Fashionable Ballet Flats, Tan Croc print Tieks, A timeless texture., <https://web.archive.org/web/20100819165503/https://tieks.com/>, Aug. 19, 2010, 1 page.

Tieks by Gavrieli—Foldable Fashionable Ballet Flats, Be a little wild . . . even when you're not., <https://web.archive.org/web/210092020755/https://tieks.com/>, Sep. 2, 2010, 1 page.

Tieks by Gavrieli—Foldable Fashionable Ballet Flats, Obsidian Black, When workdays spill over into party nights. <https://web.archive.org/web/20100902020755/https://tieks.com/>, Sep. 2, 2010, 1 page.

Tieks by Gavrieli—Foldable Fashionable Ballet Flats, Tan Croc Print, A timeless texture, <https://web.archive.org/web/20100902020755/https://tieks.com/>, Sep. 2, 2010, 1 page.

Tieks by Gavrieli—Foldable Fashionable Ballet Flats, Paradise Blue, The perfect pair for day and night, <https://web.archive.org/web/20100902020755/https://tieks.com/>, Sep. 2, 2010, 1 page.

Tieks by Gavrieli—Foldable Fashionable Ballet Flats, Fuchsia, Sweet and sultry, <https://web.archive.org/web/20100902020755/https://tieks.com/>, Sep. 2, 2010, 1 page.

Tieks by Gavrieli—Foldable Fashionable Ballet Flats, Tiek Blue Tieks, Let yourself shine, <https://web.archive.org/web/20100902020755/https://tieks.com/>, Sep. 2, 2010, 1 page.

\* cited by examiner

*Primary Examiner* — Dominic V Simone  
(74) *Attorney, Agent, or Firm* — Morgan, Lewis & Bockius LLP

(57)

#### CLAIM

The ornamental design for a single-sole shoe with purple outpatch sole, as shown and described.

#### DESCRIPTION

The patent or application file contains at least one drawing executed in color. Copies of this patent or patent application publication with color drawing(s) will be provided by the Office upon request and payment of the necessary fee.

FIG. 1 is a perspective view of an embodiment of our new design of a single-sole shoe with purple outpatch sole, where the purple portions are indicated using the USPTO convention of dashed vertical lines for purple color including any one of Pantone PMS 227-Pantone PMS 241, any one of Pantone PMS 243-Pantone PMS 266, any one of Pantone PMS 268-Pantone PMS 276, any one of Pantone PMS 511-Pantone PMS 514, any one of Pantone PMS 518-Pantone PMS 520, any one of Pantone PMS 522-Pantone PMS 530, any one of Pantone PMS 663-Pantone PMS 669, Pantone PMS 807, Pantone PMS 814, any one of Pantone PMS 2385-Pantone PMS 2765, any one of Pantone PMS 5115-Pantone PMS 5125, any one of Pantone PMS 5145-Pantone PMS 5275, any one of RAL 4001-RAL 4009, RAL 4011, or RAL 4012;

FIG. 2 is a first side view of the design of FIG. 1;

FIG. 3 is a second side view of the design of FIG. 1;

FIG. 4 is a top view of the design of FIG. 1;

FIG. 5 is a bottom view of the design of FIG. 1;

FIG. 6 is a front view of the design of FIG. 1;  
FIG. 7 is a back view of the design of FIG. 1;  
FIG. 8 is a perspective view of yet another embodiment of our new design of a single-sole shoe with purple outpatch sole, where the purple portions indicate the purple color Pantone PMS 242;  
FIG. 9 is a first side view of the design of FIG. 8;  
FIG. 10 is a second side view of the design of FIG. 8;  
FIG. 11 is a top view of the design of FIG. 8;  
FIG. 12 is a bottom view of the design of FIG. 8;  
FIG. 13 is a front view of the design of FIG. 8;  
FIG. 14 is a back view of the design of FIG. 8;  
FIG. 15 is a perspective view of yet another embodiment of our new design of a single-sole shoe with purple outpatch sole, where the purple portions indicate the purple color Pantone PMS 267;  
FIG. 16 is a first side view of the design of FIG. 15;  
FIG. 17 is a second side view of the design of FIG. 15;  
FIG. 18 is a top view of the design of FIG. 15;  
FIG. 19 is a bottom view of the design of FIG. 15;  
FIG. 20 is a front view of the design of FIG. 15;  
FIG. 21 is a back view of the design of FIG. 15;  
FIG. 22 is a perspective view of yet another embodiment of our new design of a single-sole shoe with purple outpatch sole, where the purple portions indicate the purple color Pantone PMS 521;  
FIG. 23 is a first side view of the design of FIG. 22;  
FIG. 24 is a second side view of the design of FIG. 22;  
FIG. 25 is a top view of the design of FIG. 22;

FIG. 26 is a bottom view of the design of FIG. 22;  
FIG. 27 is a front view of the design of FIG. 22;  
FIG. 28 is a back view of the design of FIG. 22;  
FIG. 29 is a perspective view of yet another embodiment of our new design of a single-sole shoe with purple outpatch sole, where the purple portions indicate the purple color Pantone PMS 5135;  
FIG. 30 is a first side view of the design of FIG. 29;  
FIG. 31 is a second side view of the design of FIG. 29;  
FIG. 32 is a top view of the design of FIG. 29;  
FIG. 33 is a bottom view of the design of FIG. 29;  
FIG. 34 is a front view of the design of FIG. 29;  
FIG. 35 is a back view of the design of FIG. 29;  
FIG. 36 is a perspective view of yet another embodiment of our new design of a single-sole shoe with purple outpatch sole, where the purple portions indicate the purple color RAL 4010;  
FIG. 37 is a first side view of the design of FIG. 36;  
FIG. 38 is a second side view of the design of FIG. 36;  
FIG. 39 is a top view of the design of FIG. 36;  
FIG. 40 is a bottom view of the design of FIG. 36;  
FIG. 41 is a front view of the design of FIG. 36; and,  
FIG. 42 is a back view of the design of FIG. 36.  
The broken lines illustrating the upper rim elastic, the half moon patch, the groove, and the heel stripe in the above described Figures are for illustrative purposes only and form no part of the claimed design.

**1 Claim, 36 Drawing Sheets  
(25 of 36 Drawing Sheet(s) Filed in Color)**

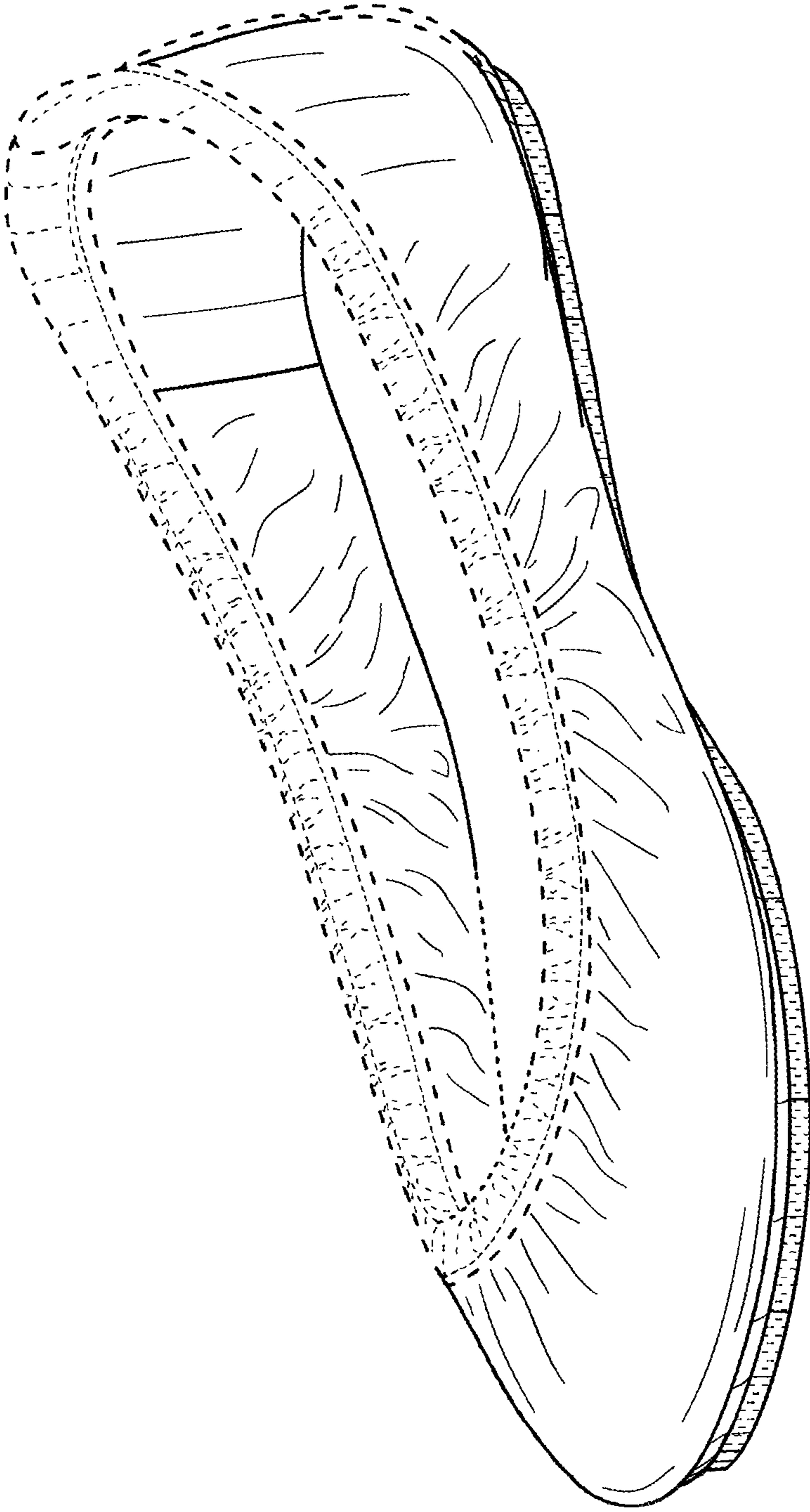

FIG. 1

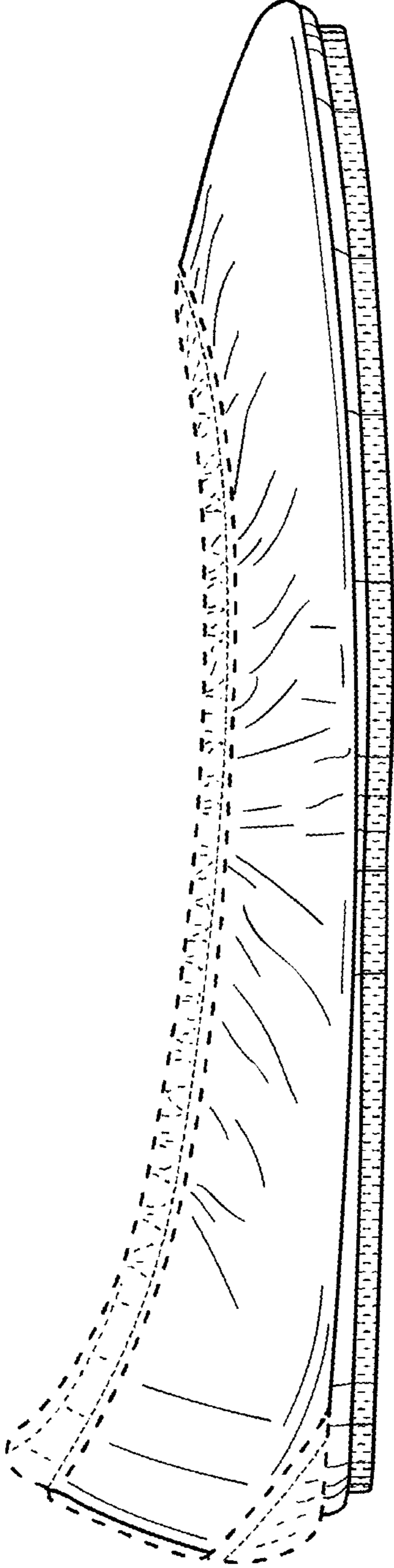

FIG. 2

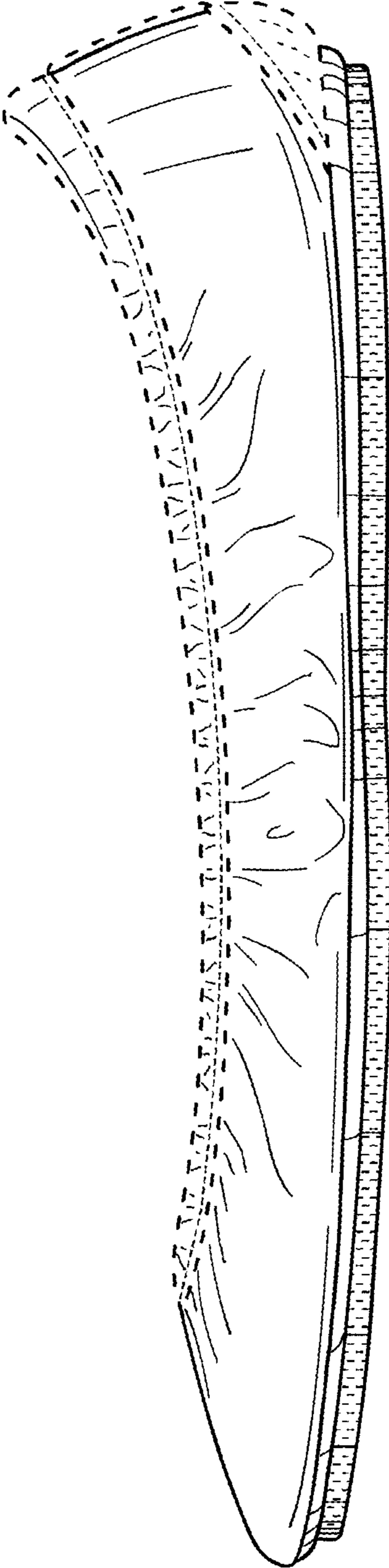

FIG. 3



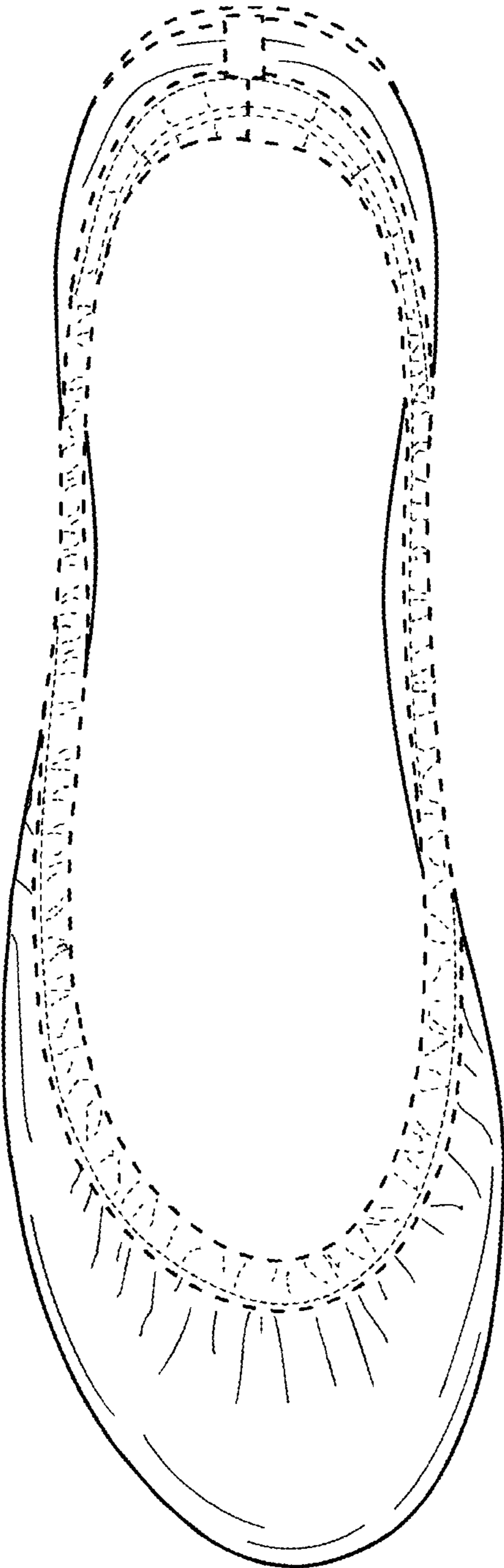

FIG. 4

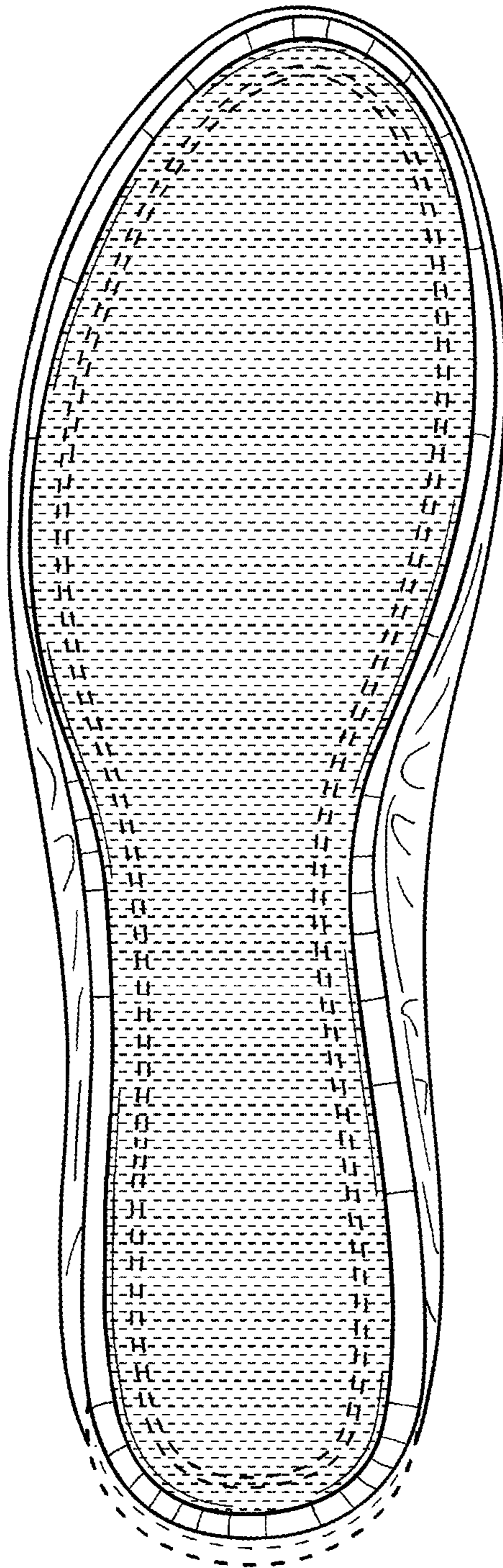

FIG. 5

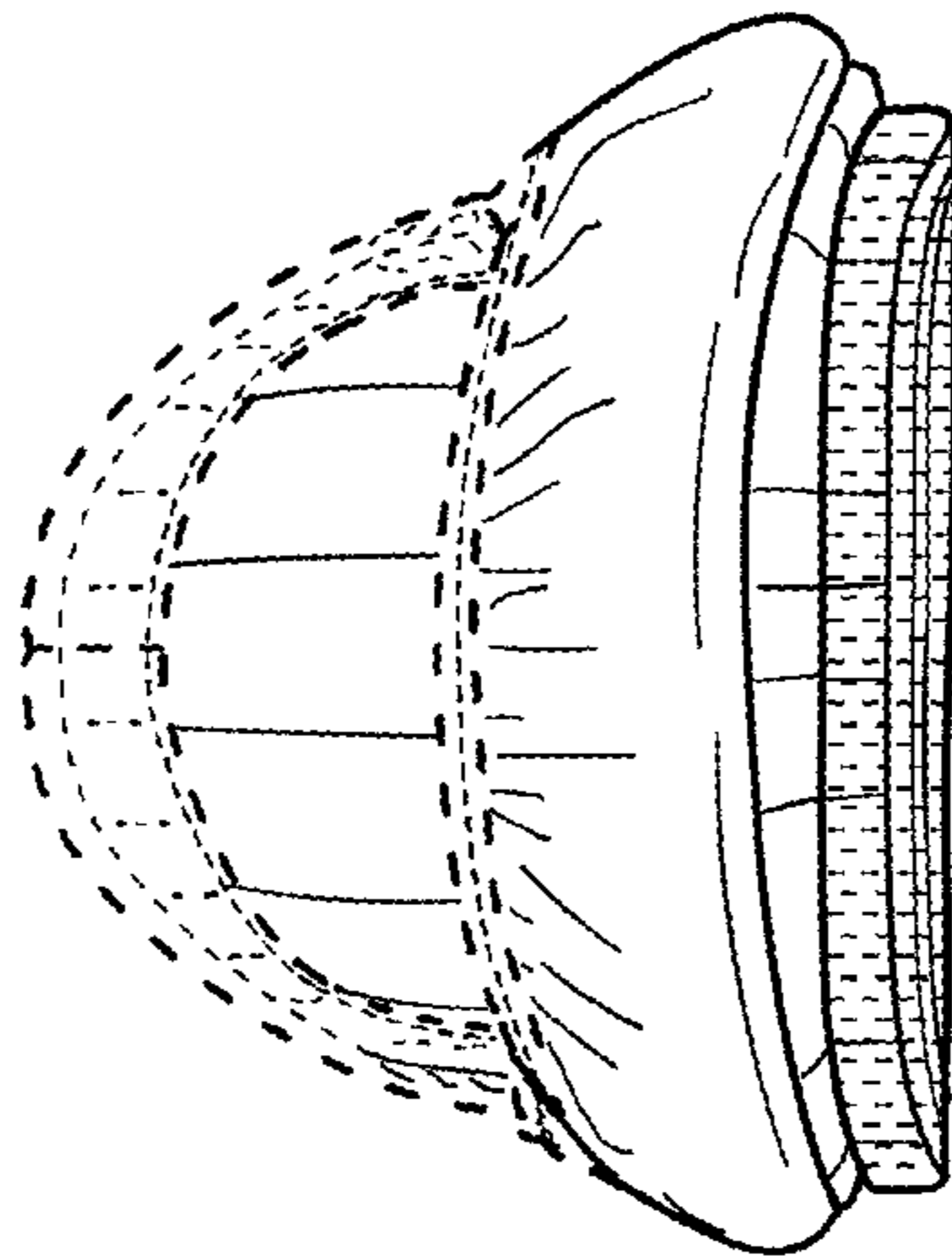

FIG. 6

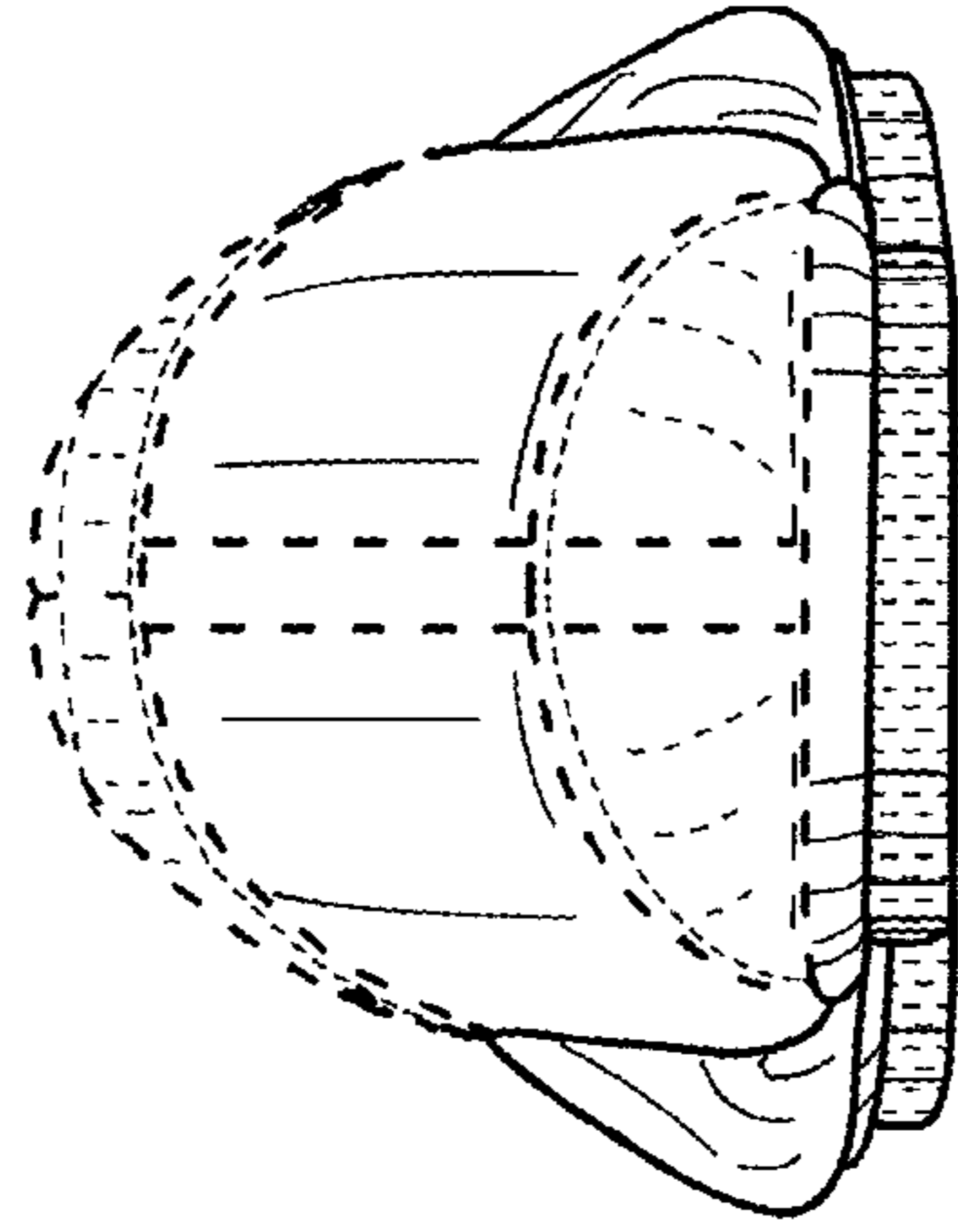

FIG. 7

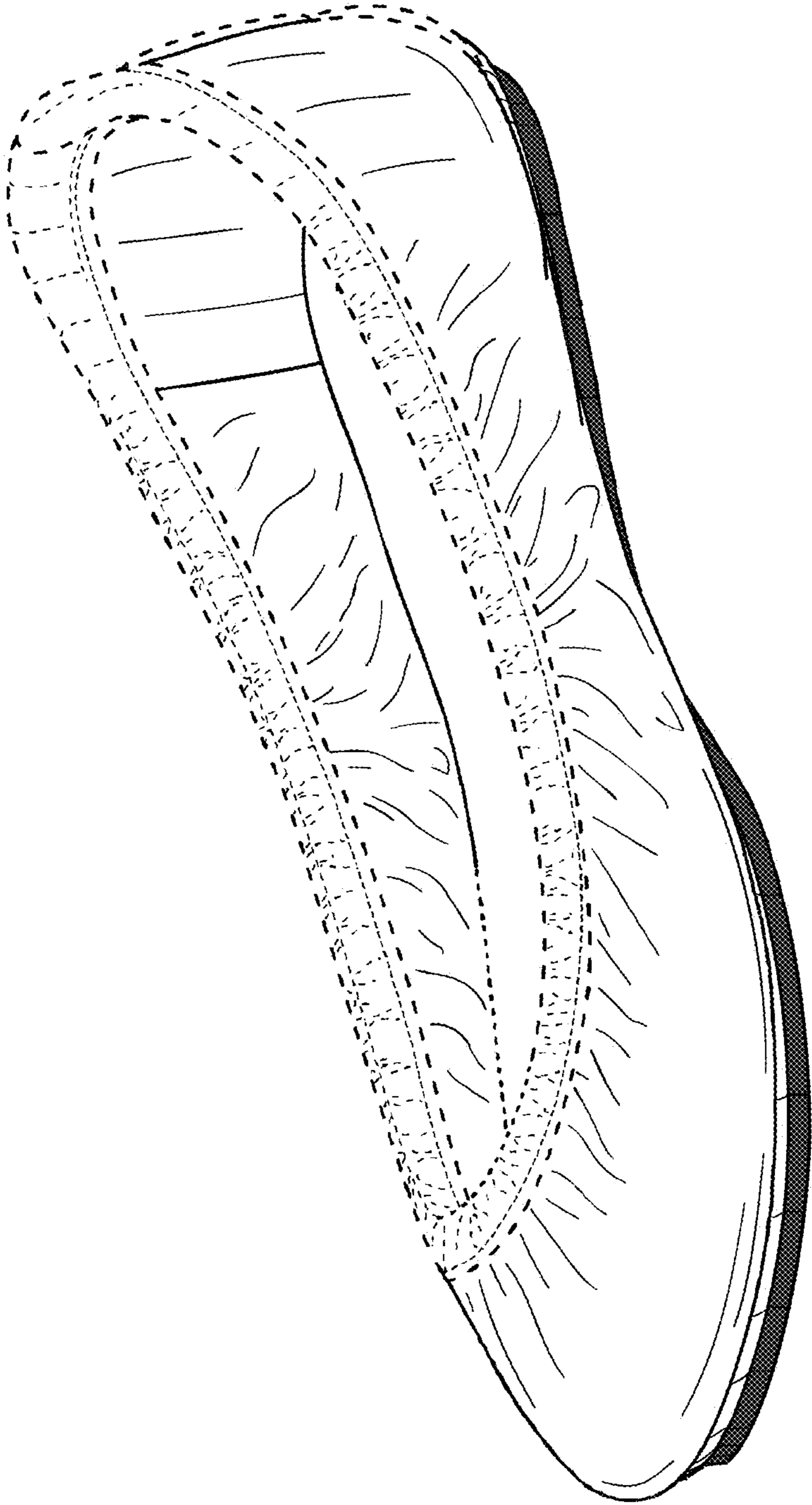

FIG. 8

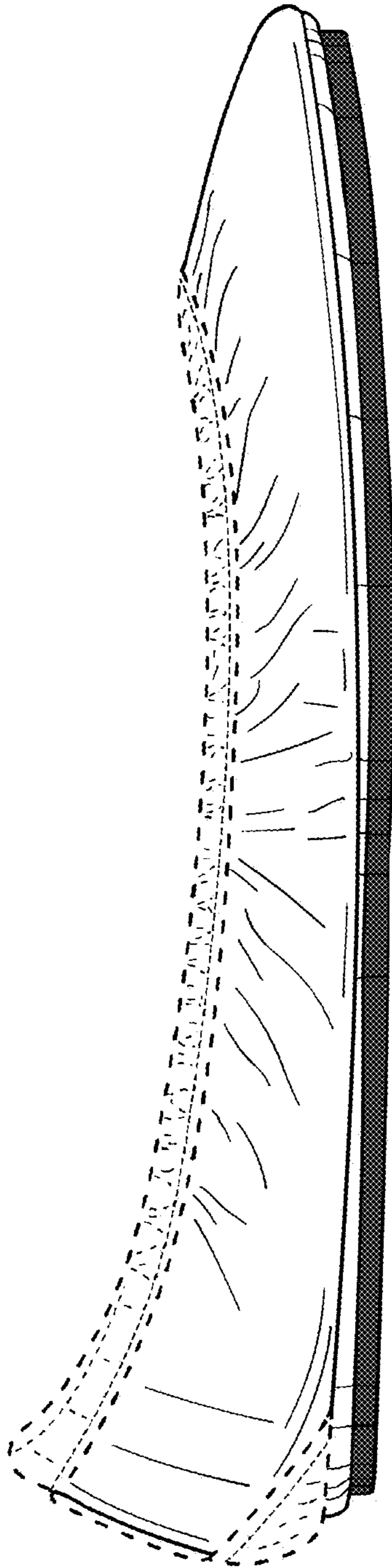

FIG. 9

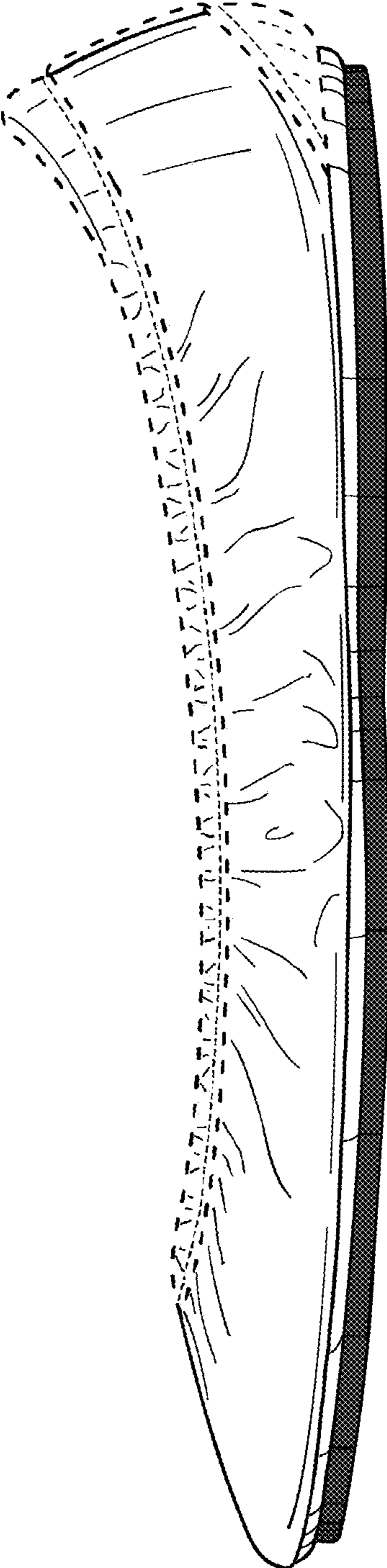

FIG. 10

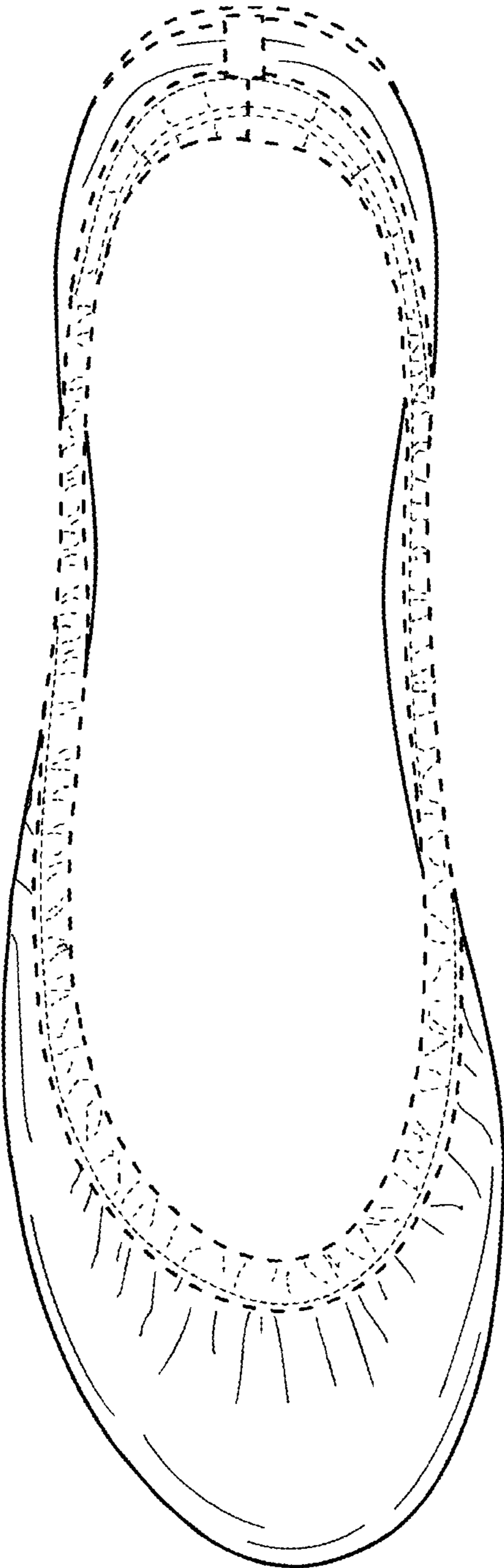

FIG. 11

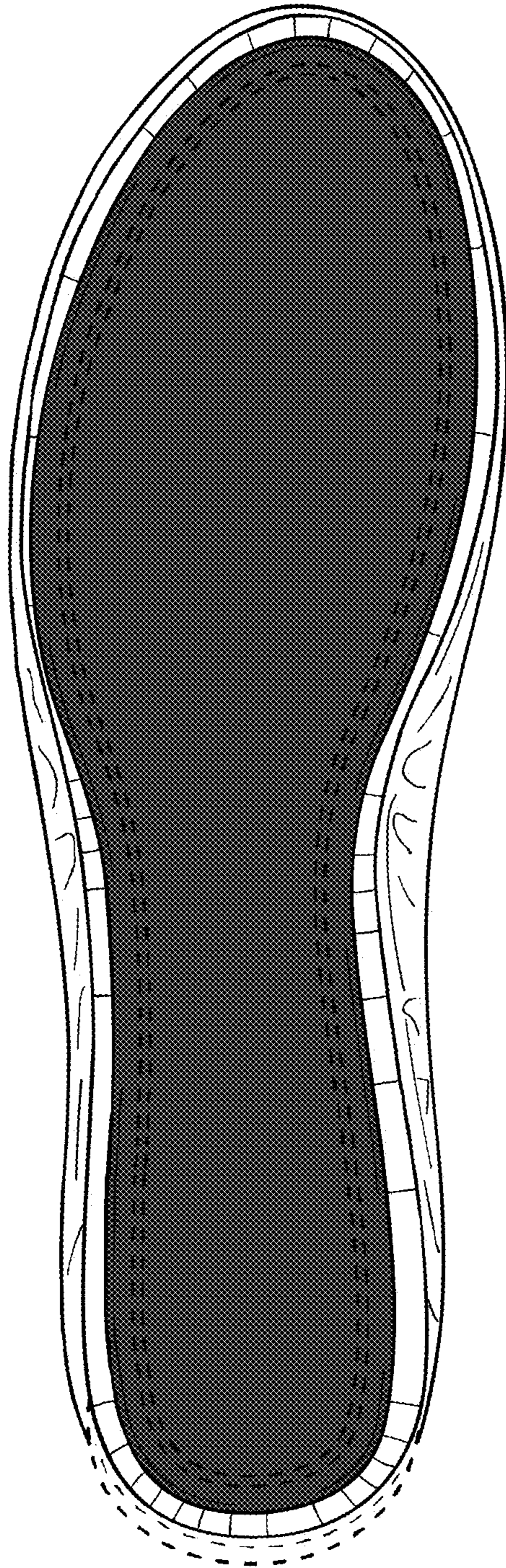

FIG. 12



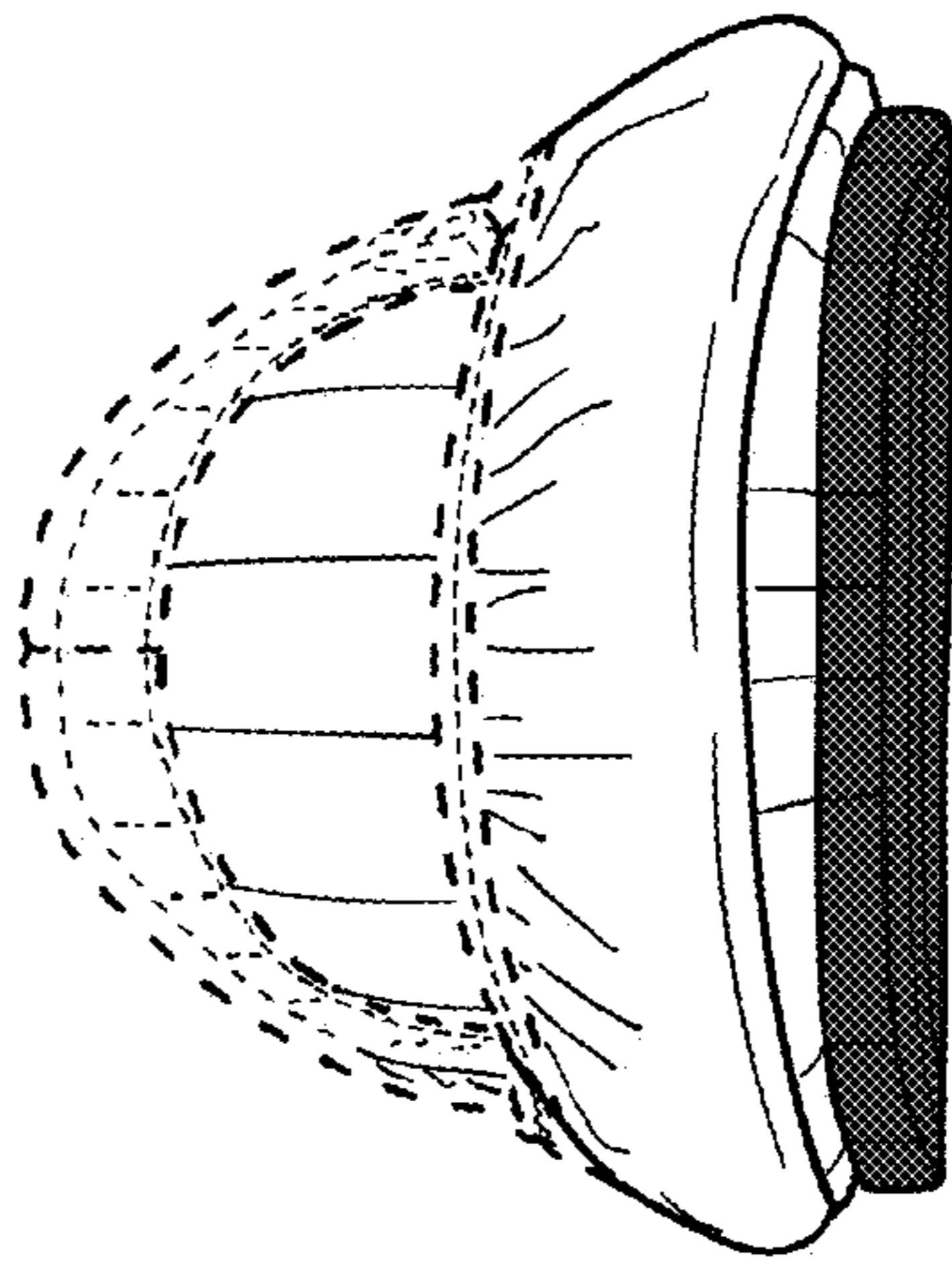

FIG. 13

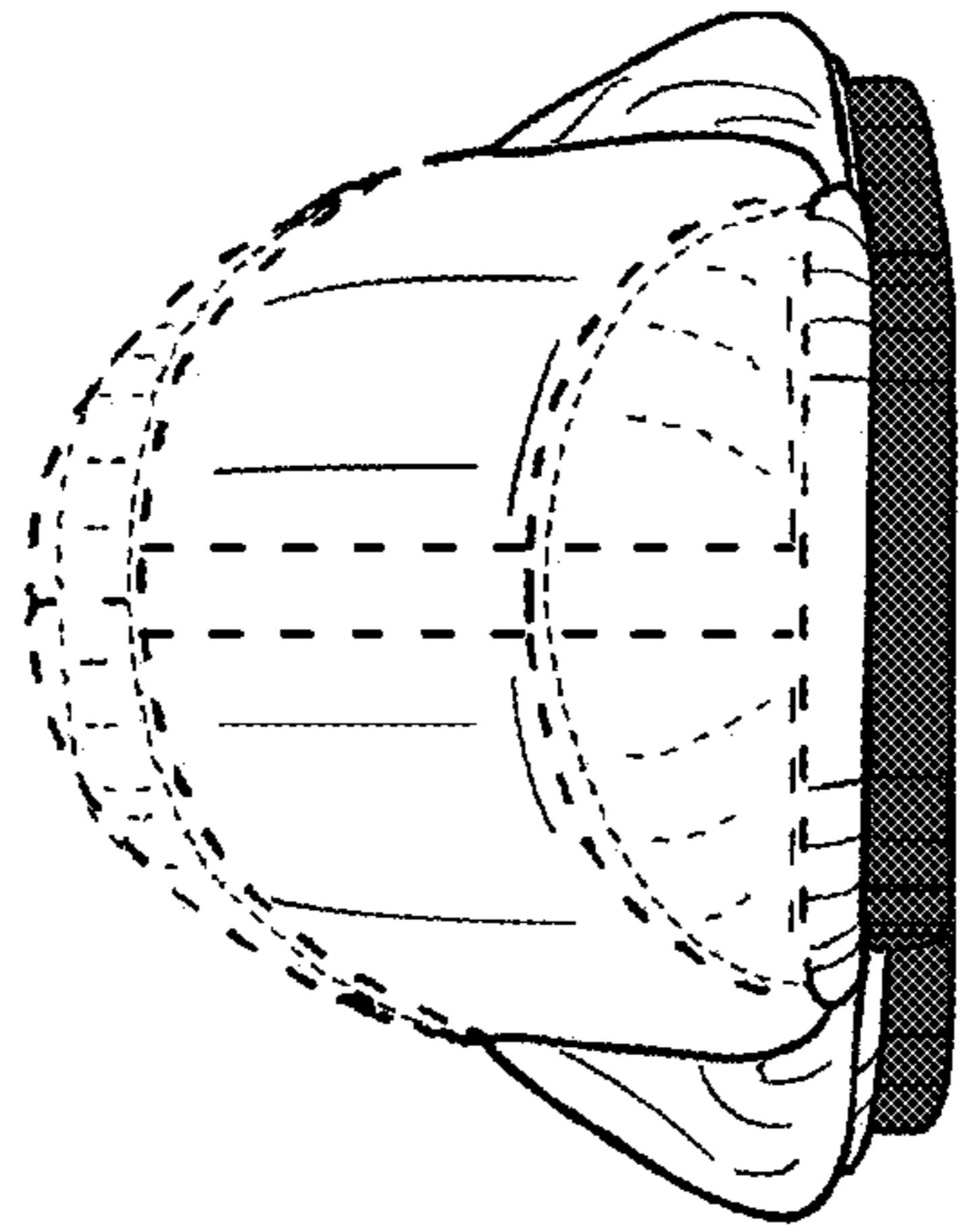

FIG. 14

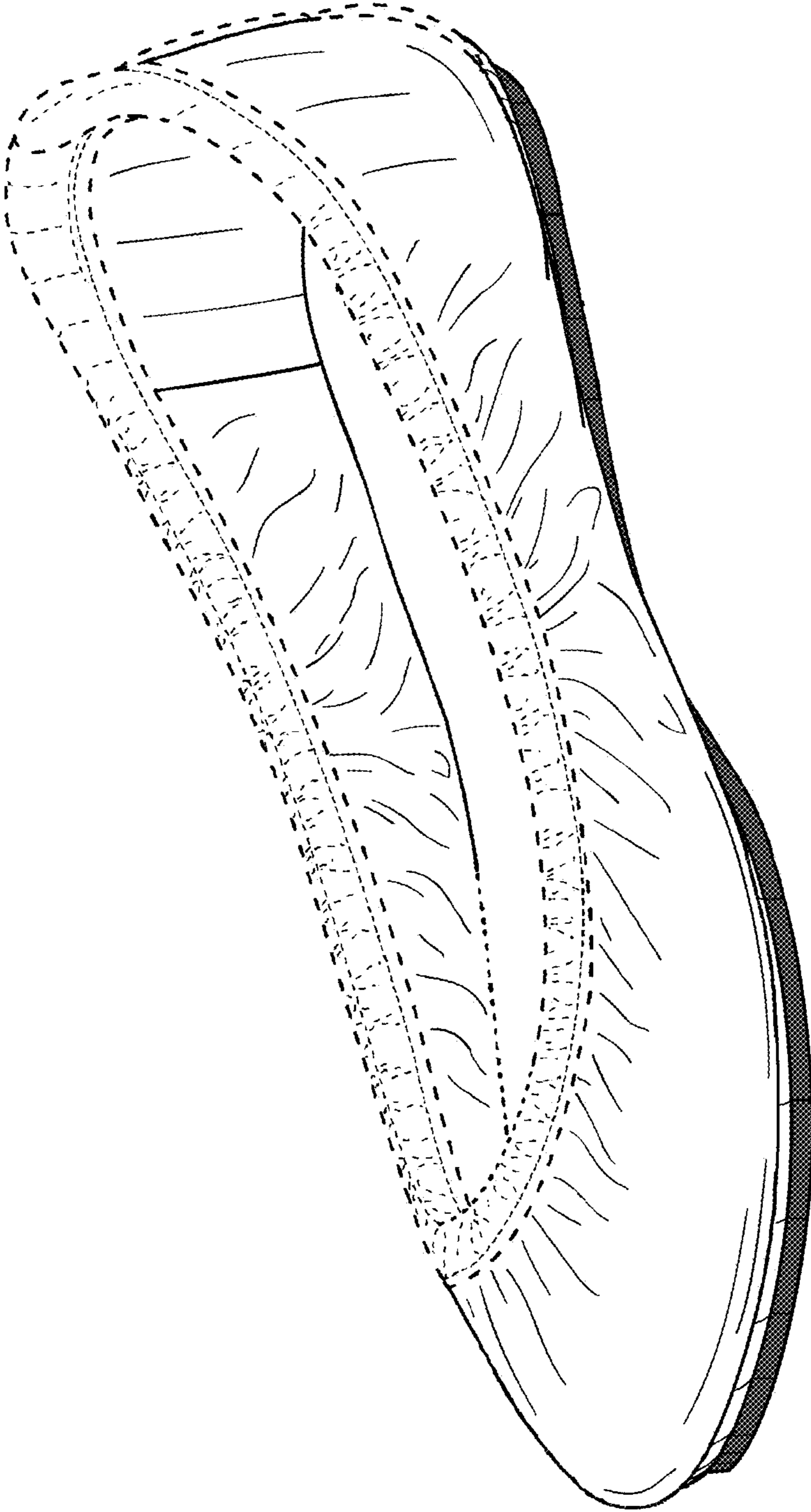

FIG. 15

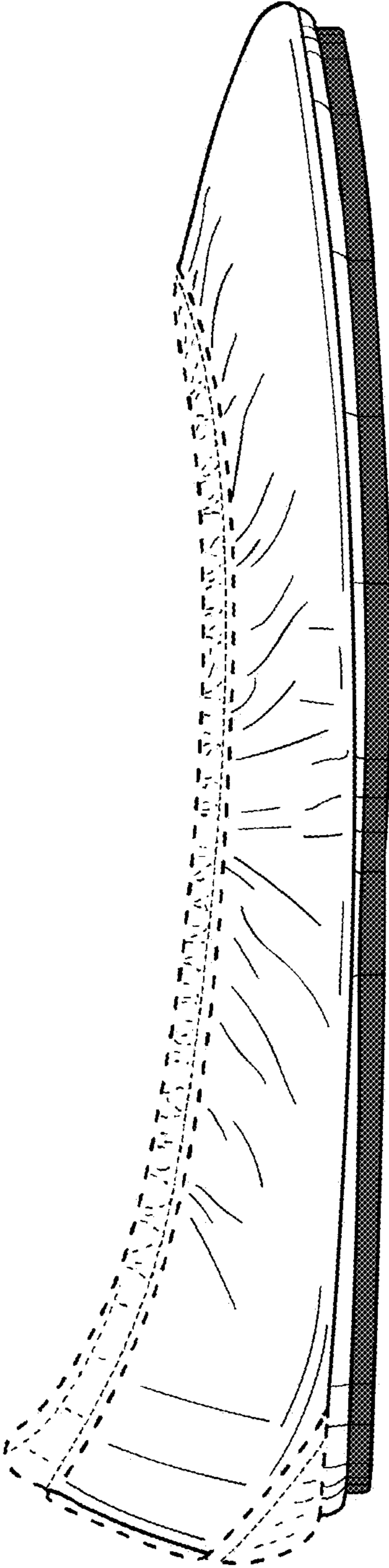

FIG. 16

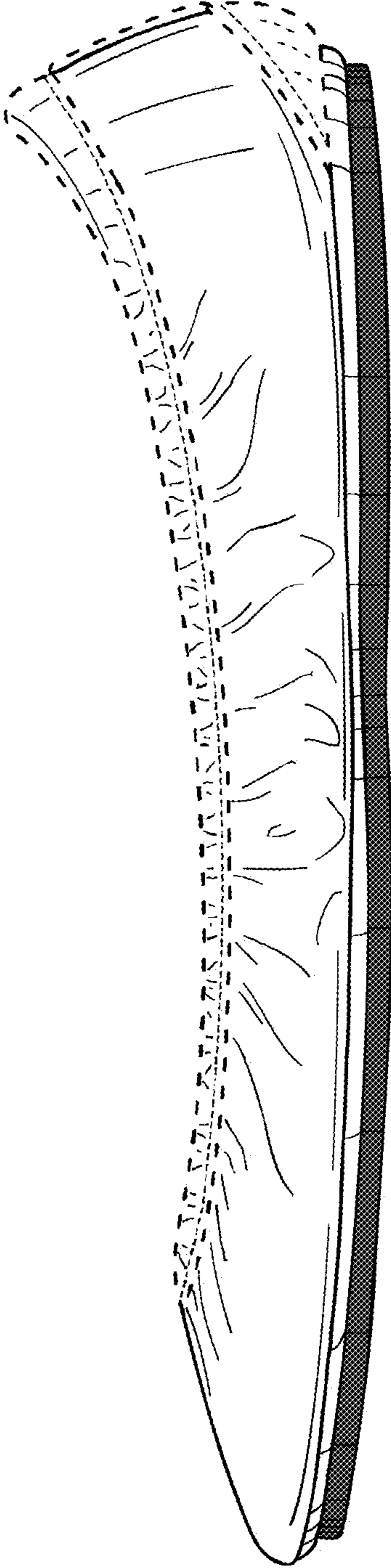

FIG. 17

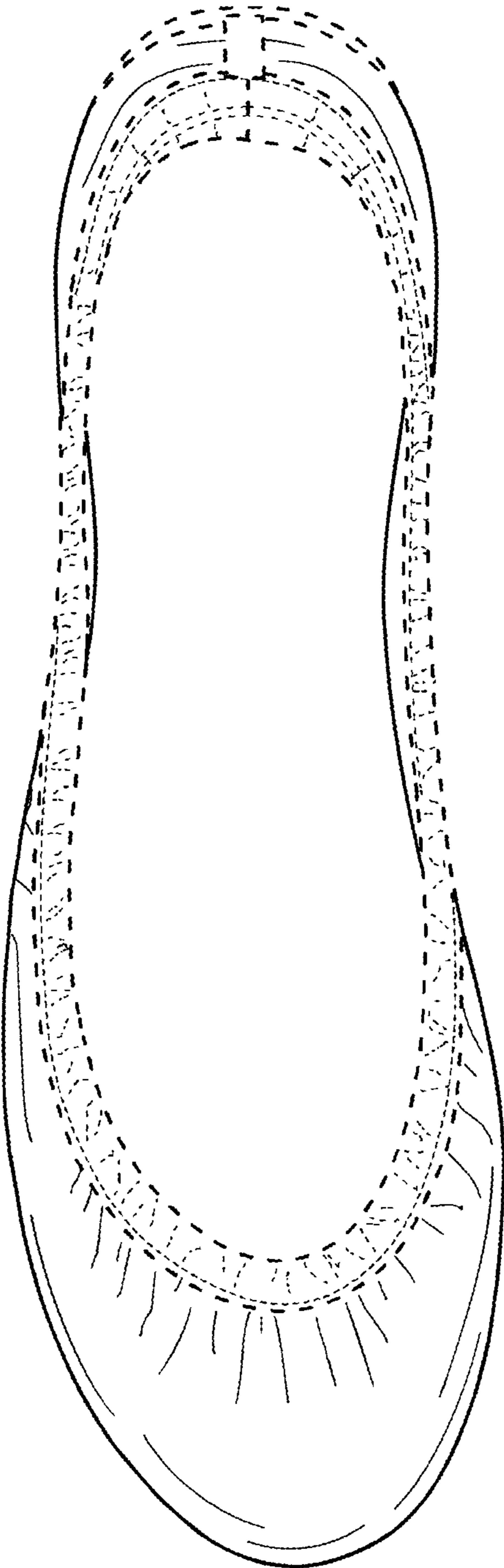

FIG. 18

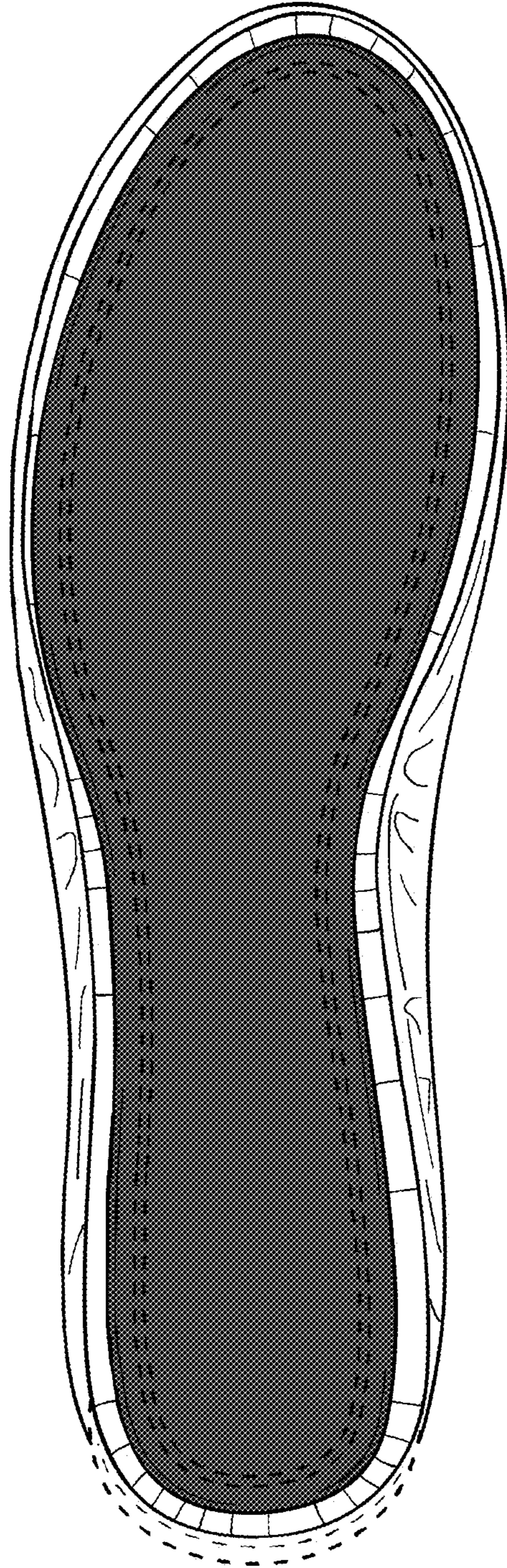

FIG. 19

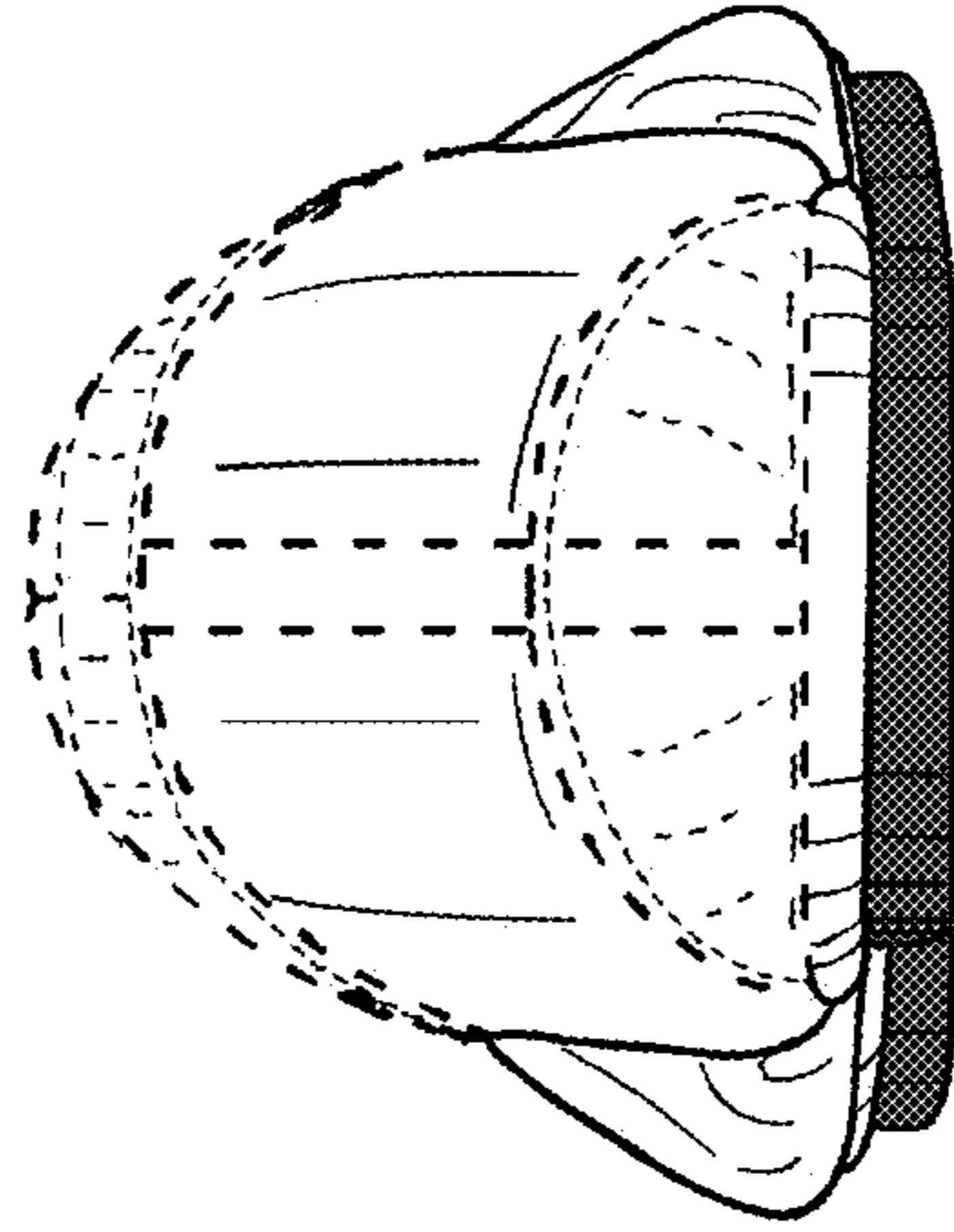

FIG. 21

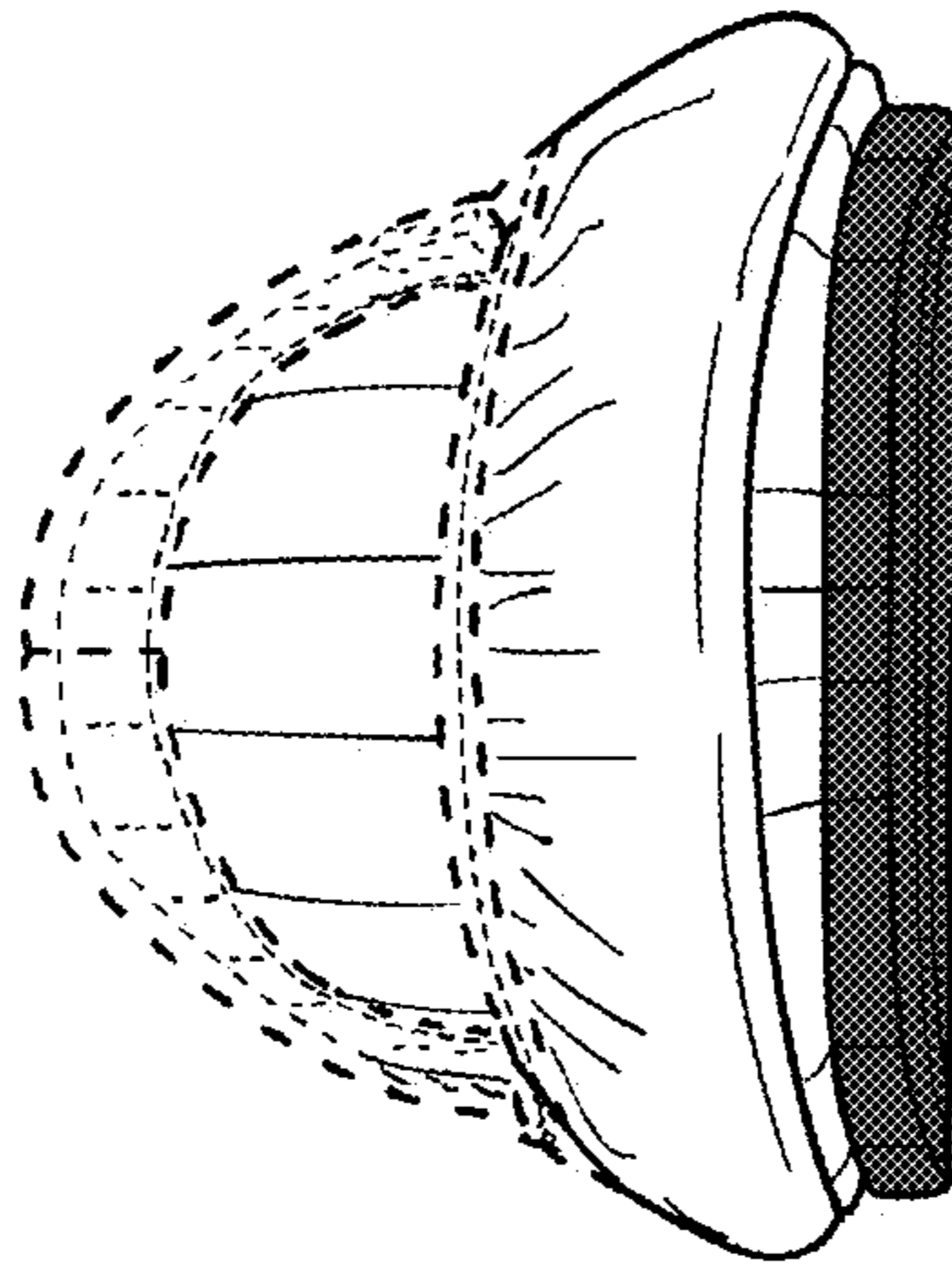

FIG. 20

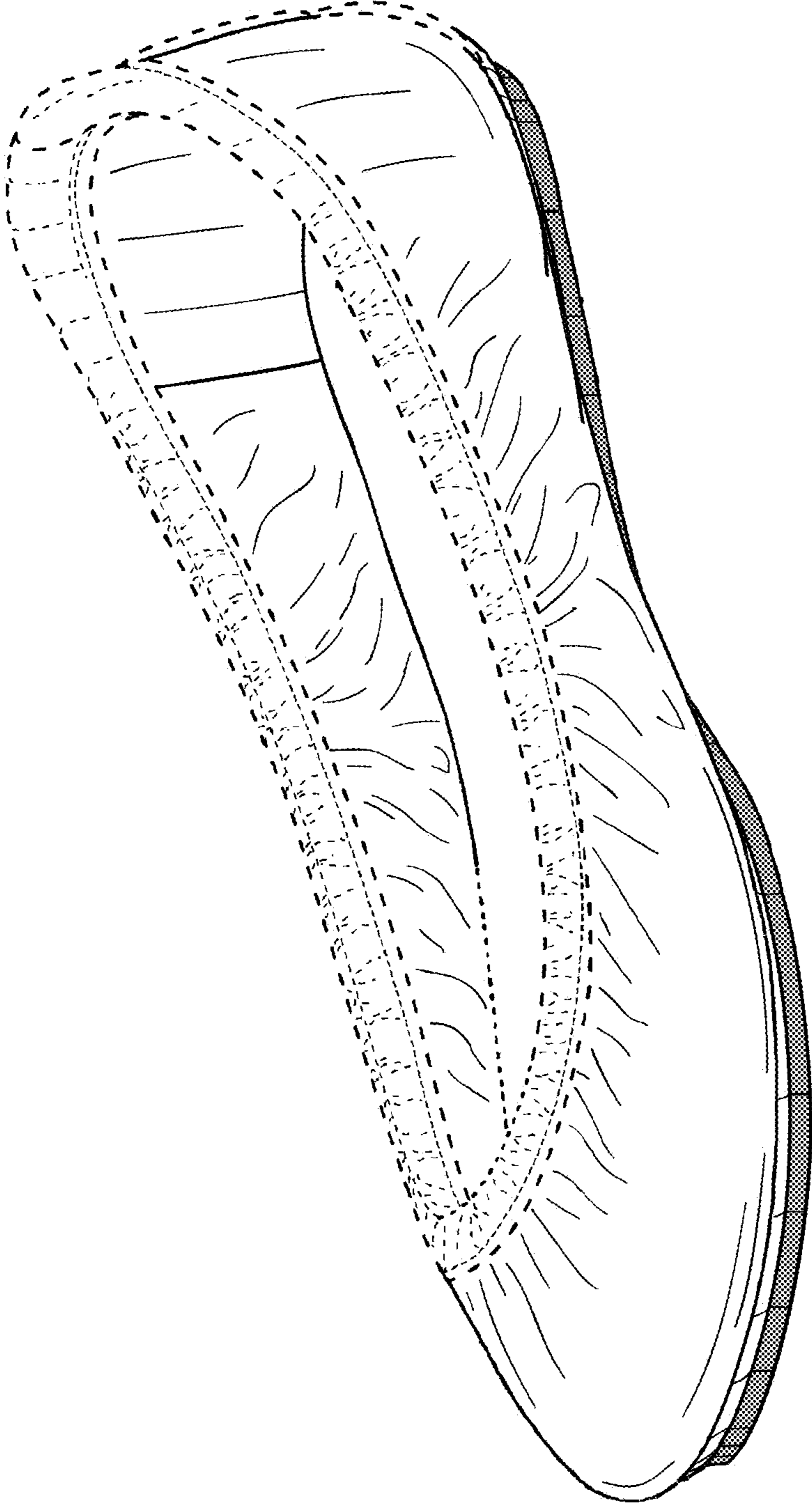

FIG. 22



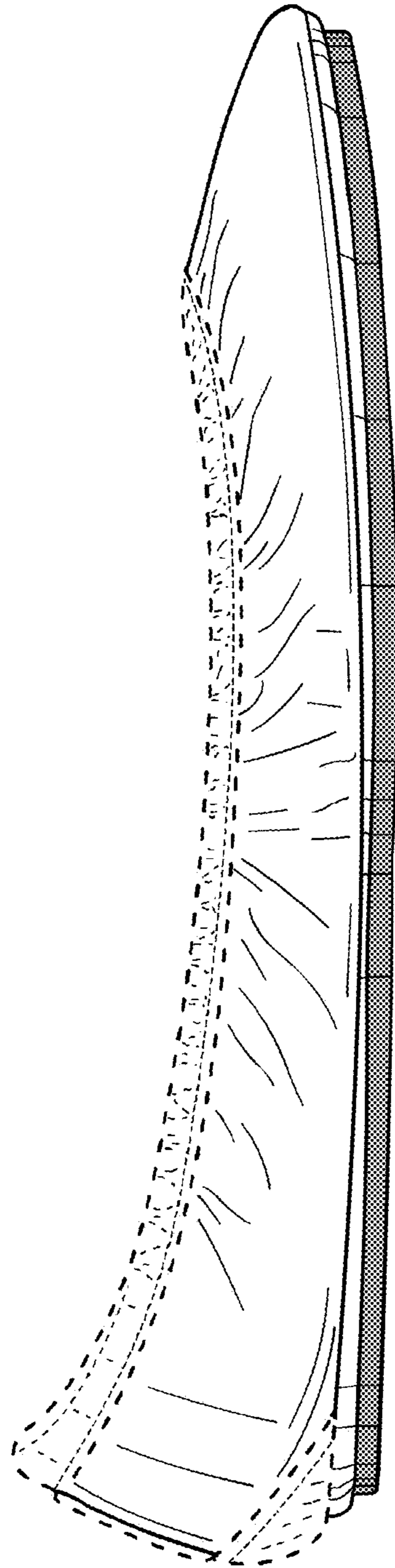

FIG. 23

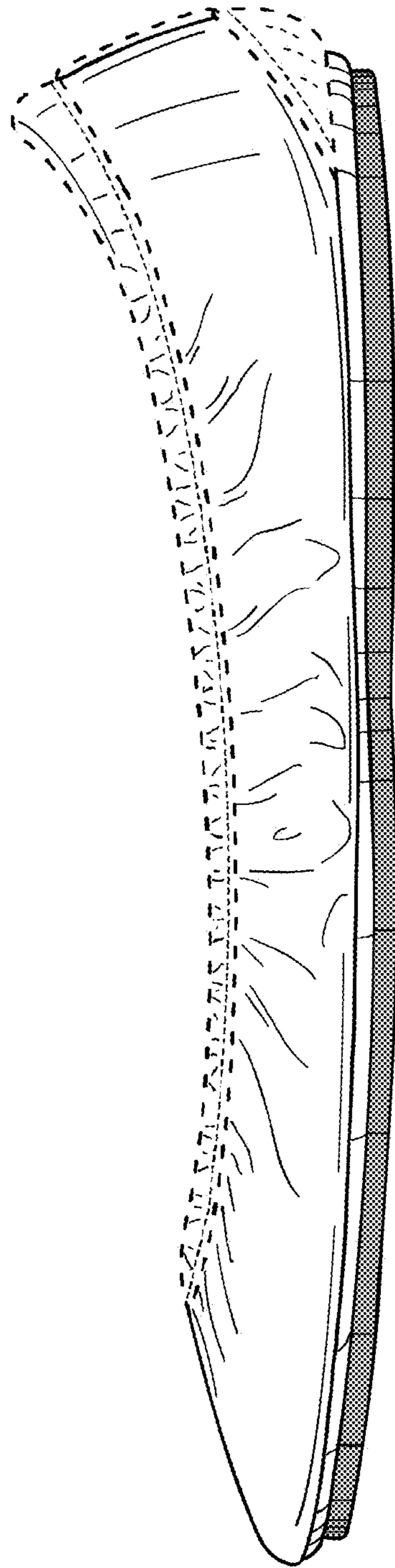

FIG. 24

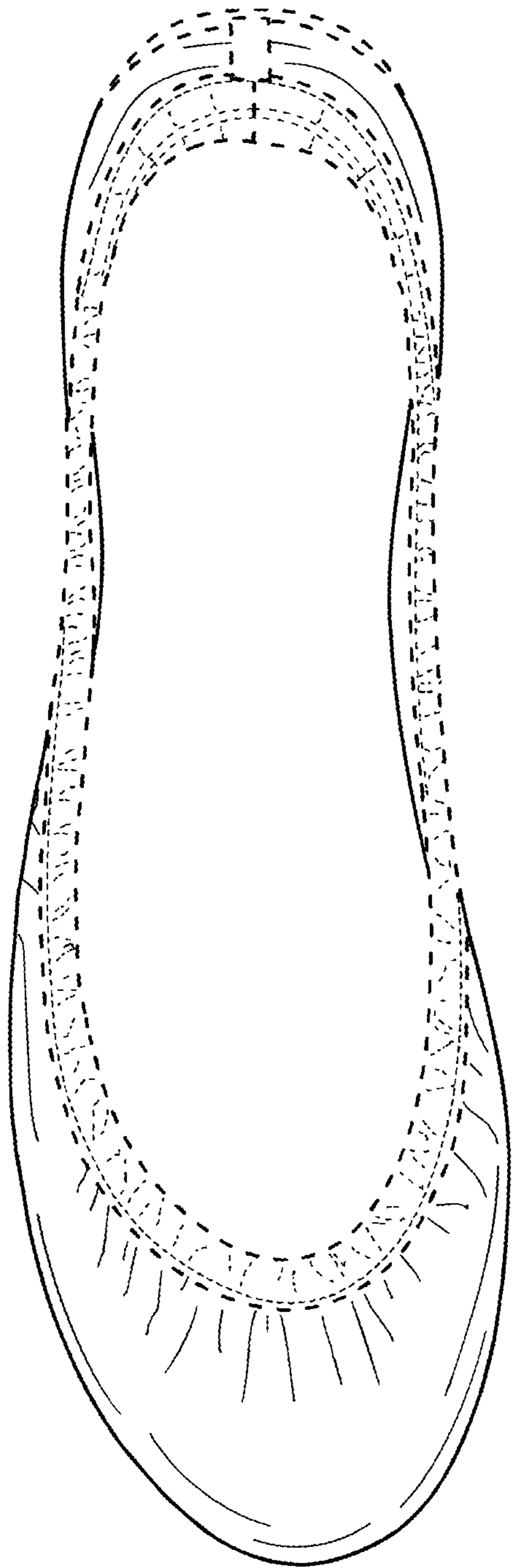

FIG. 25

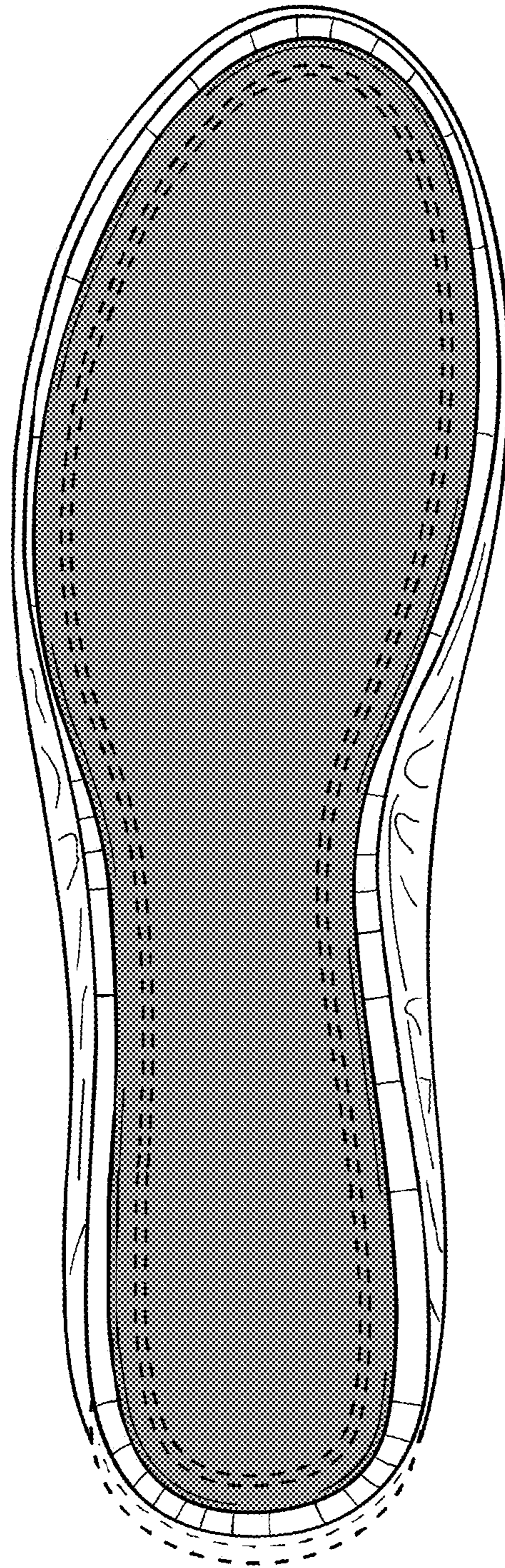

FIG. 26

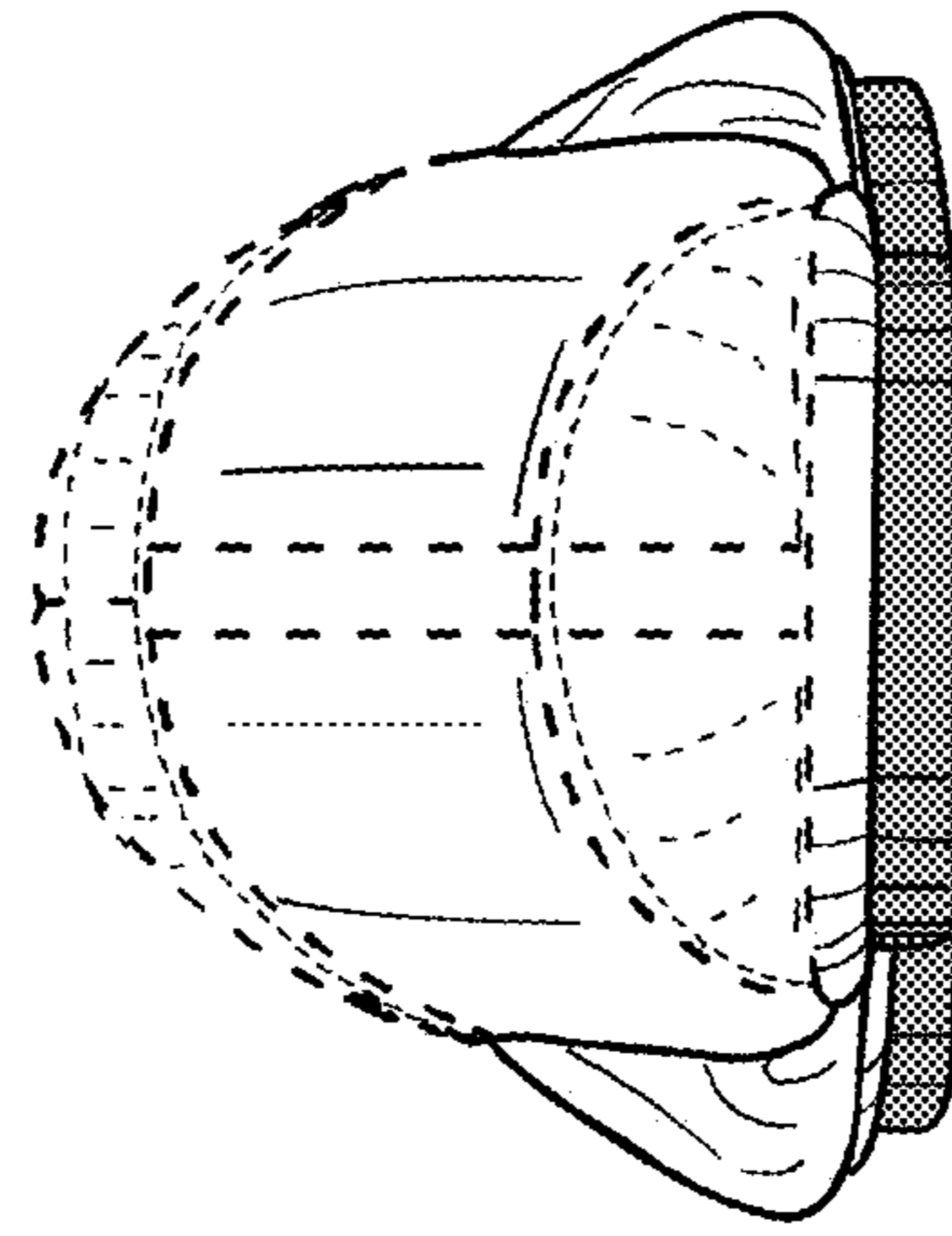

FIG. 28

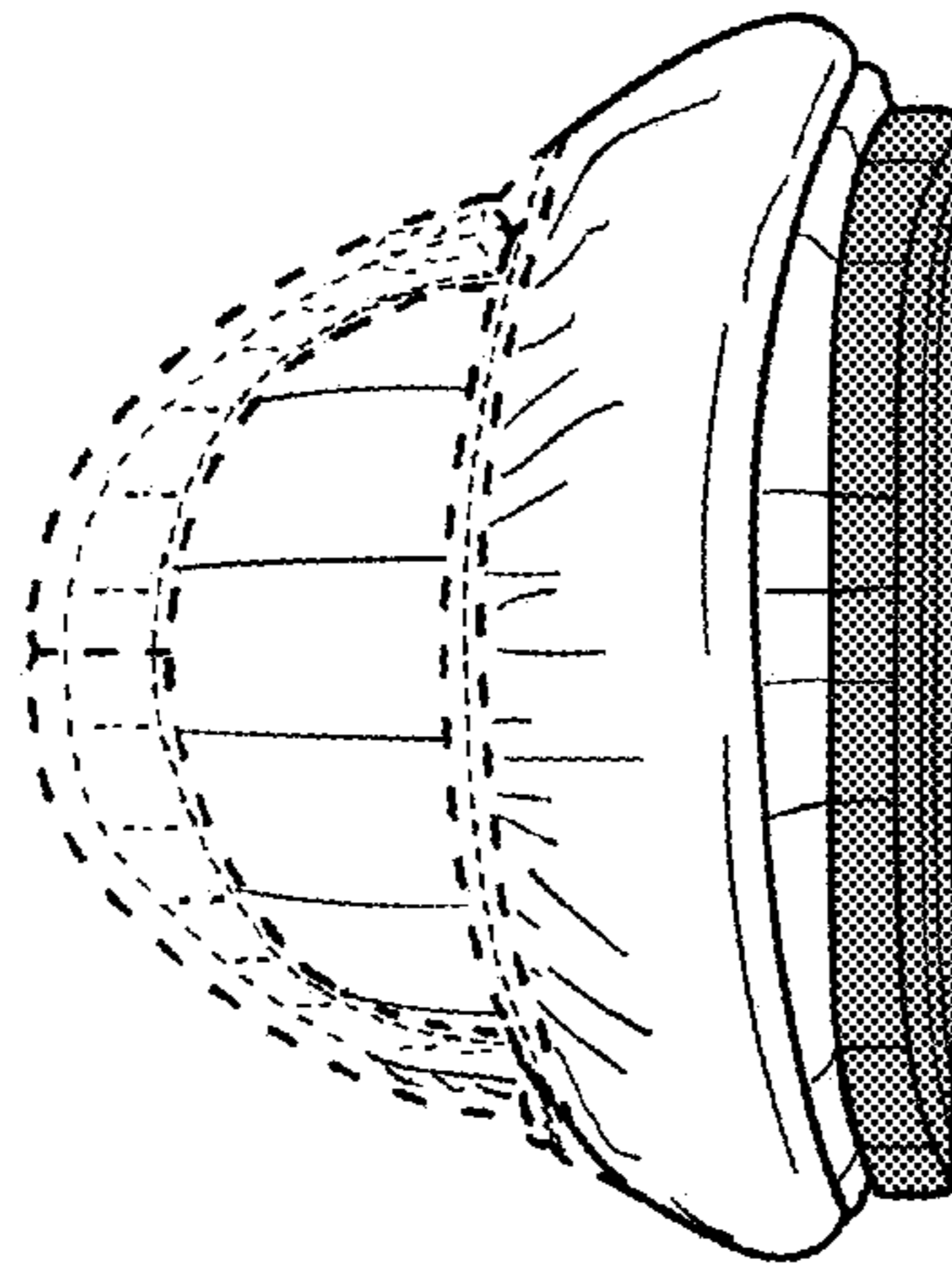

FIG. 27

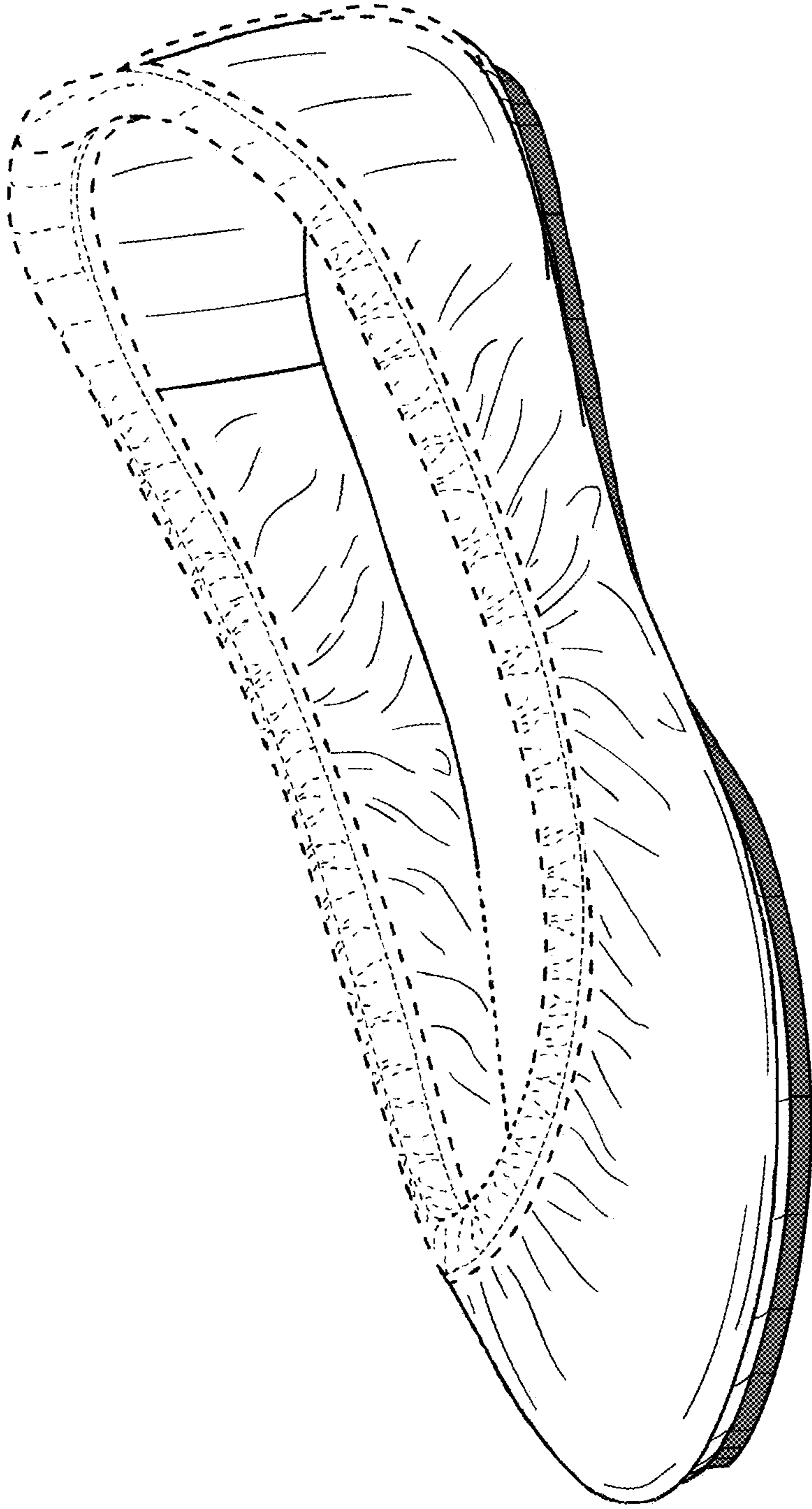

FIG. 29

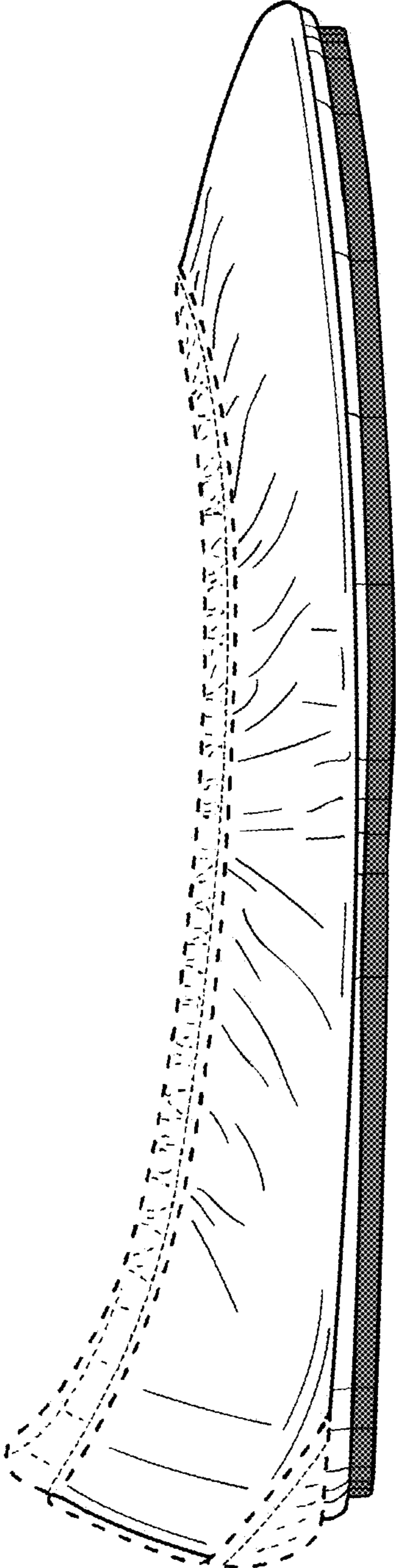

FIG. 30

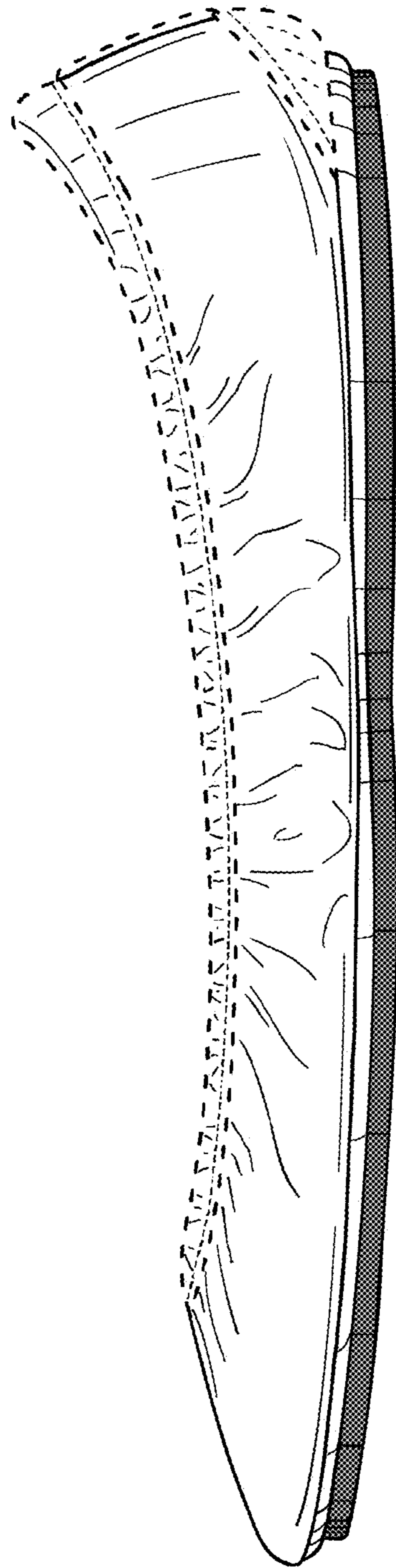

FIG. 31



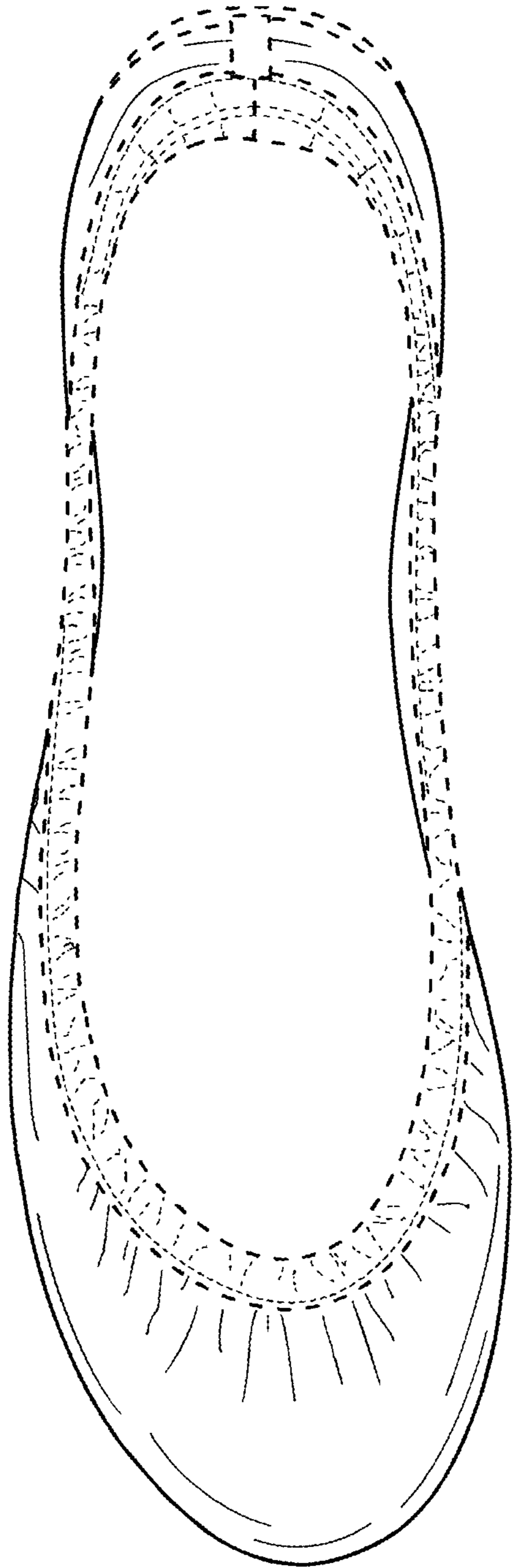

FIG. 32

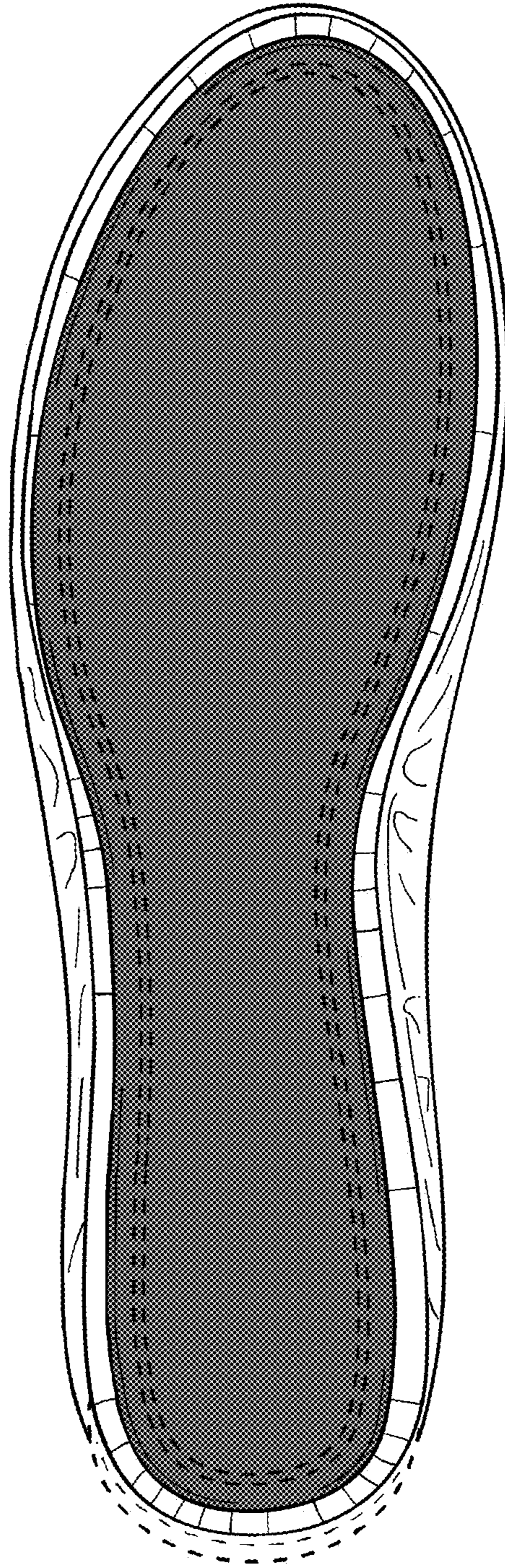

FIG. 33

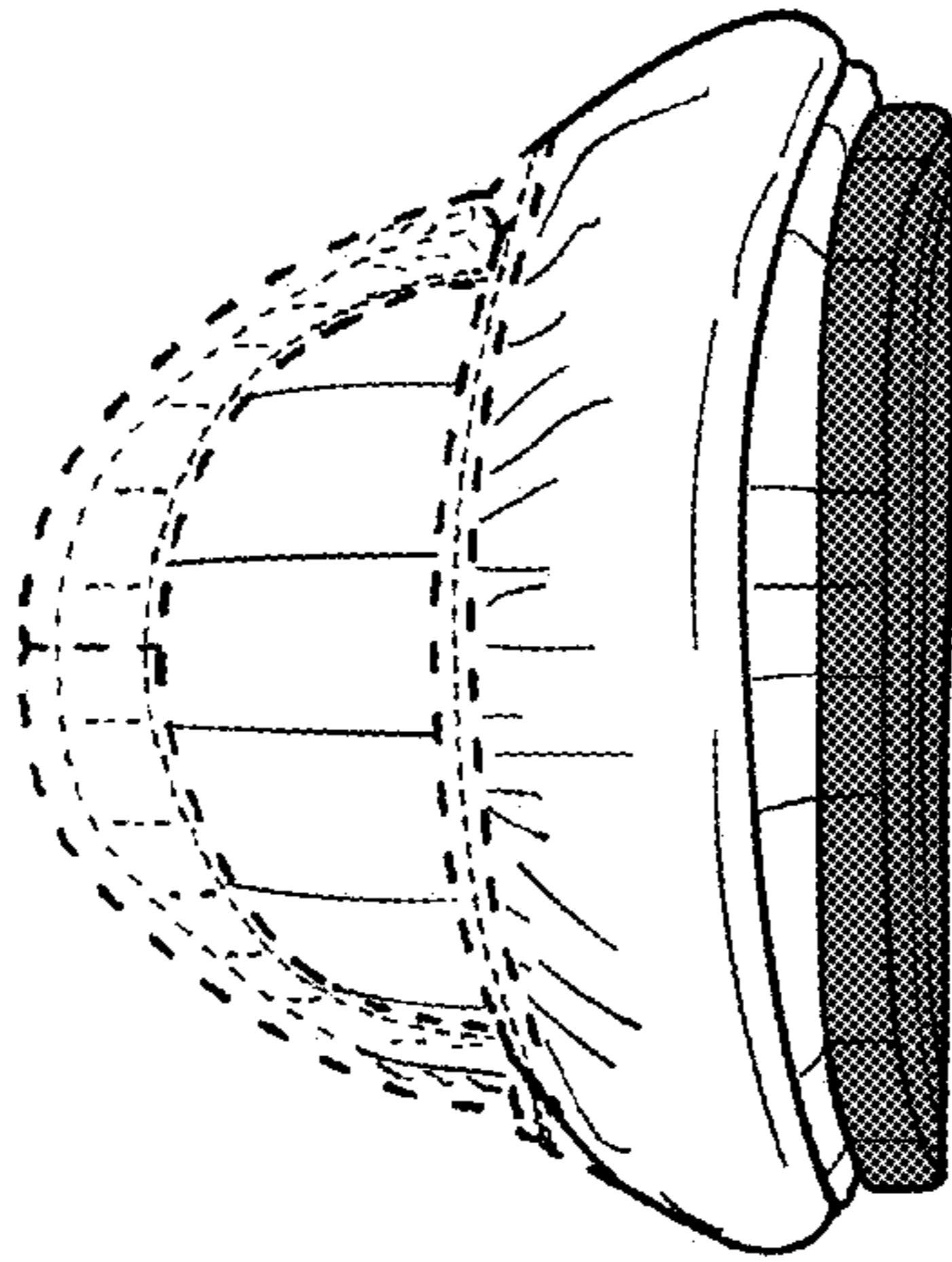

FIG. 34

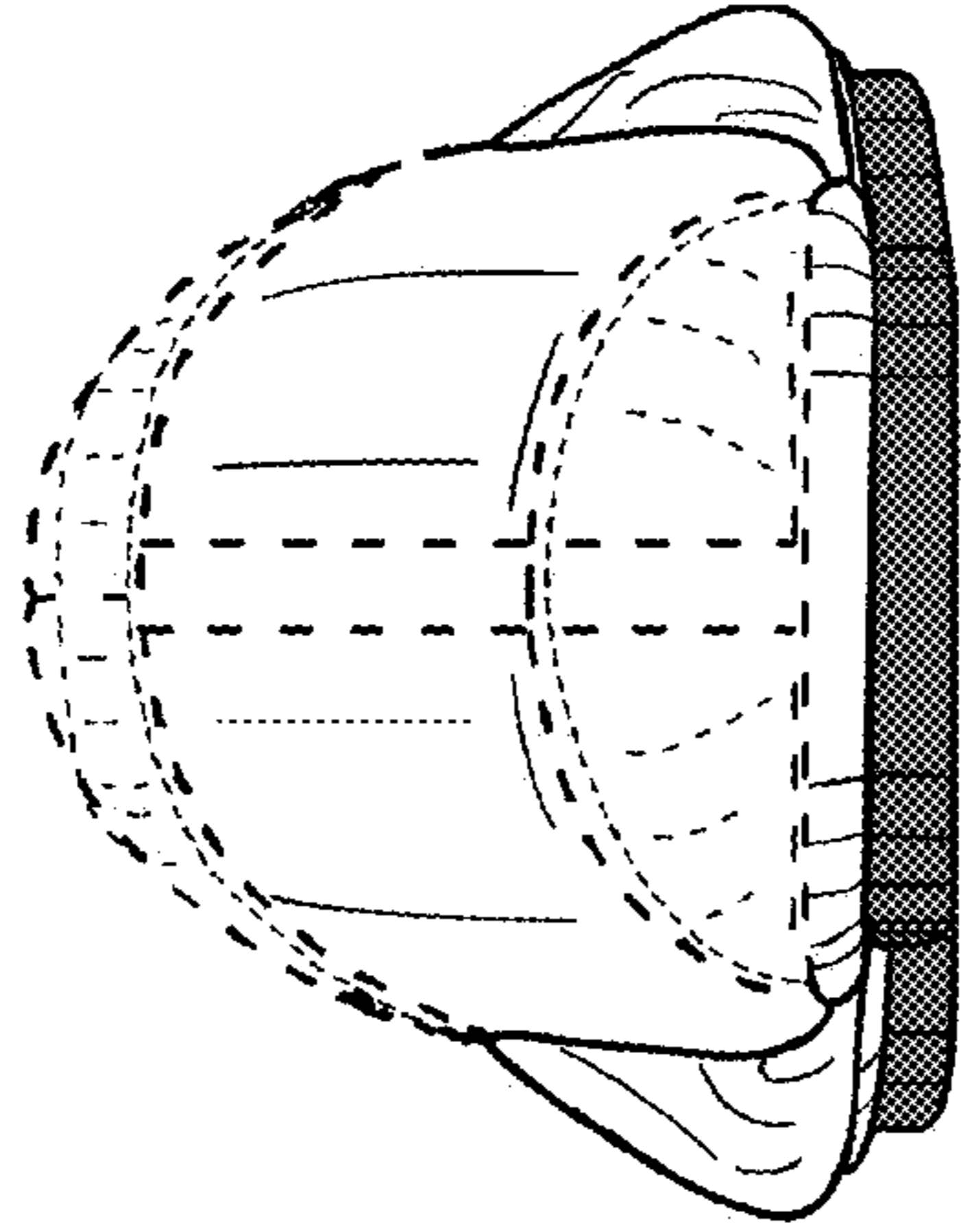

FIG. 35

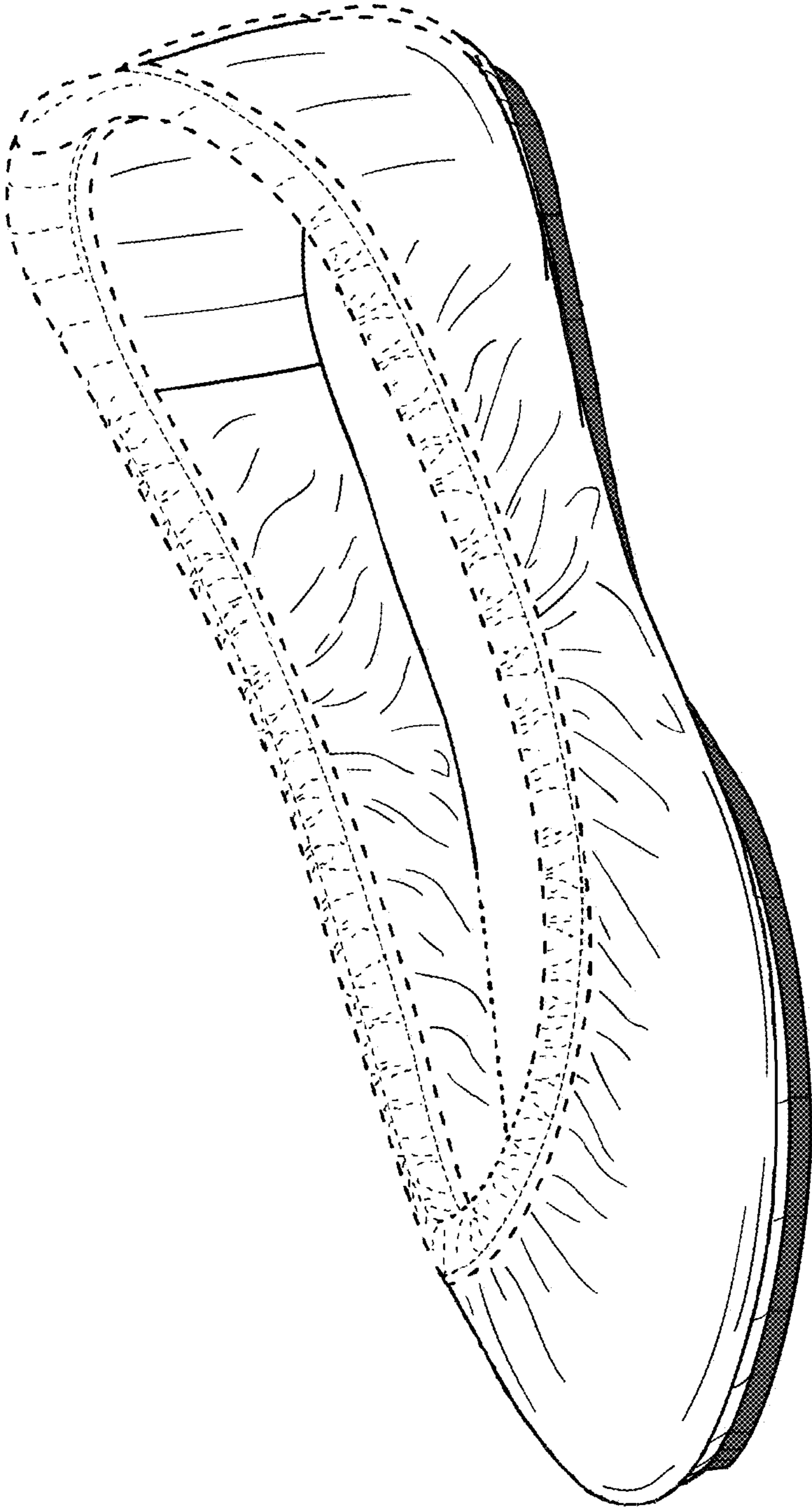

FIG. 36

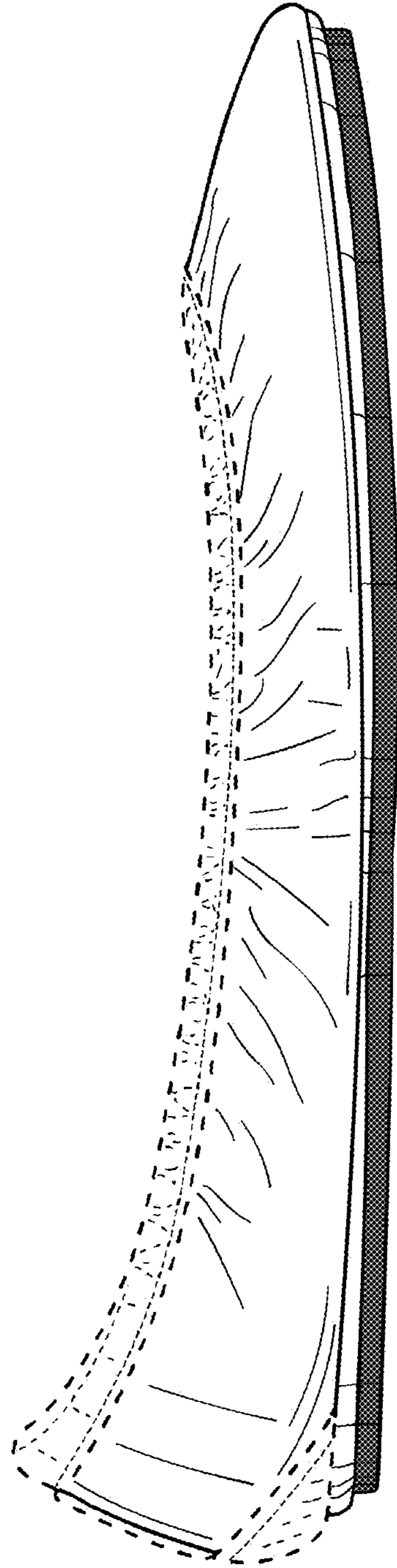

FIG. 37

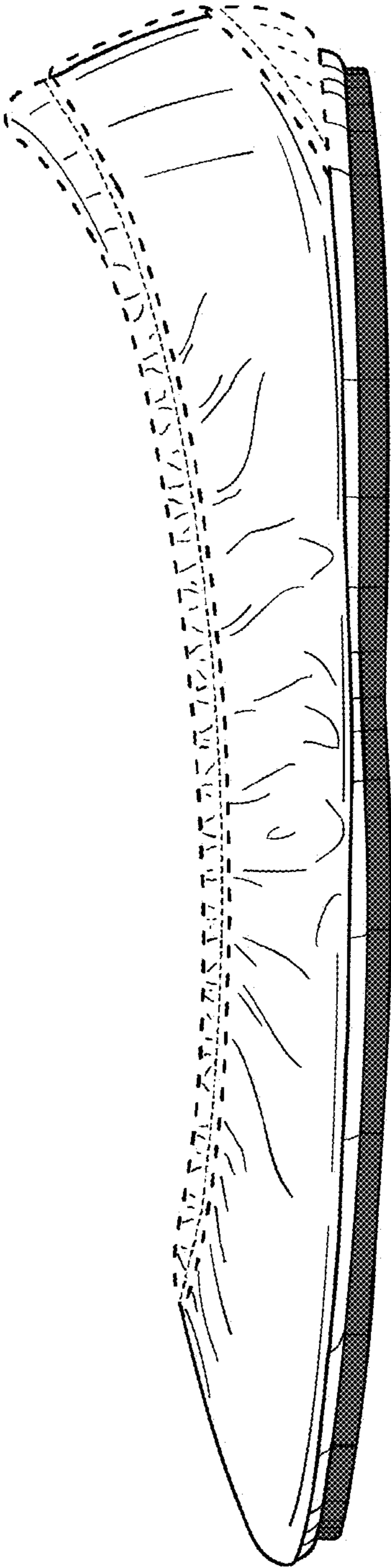

FIG. 38

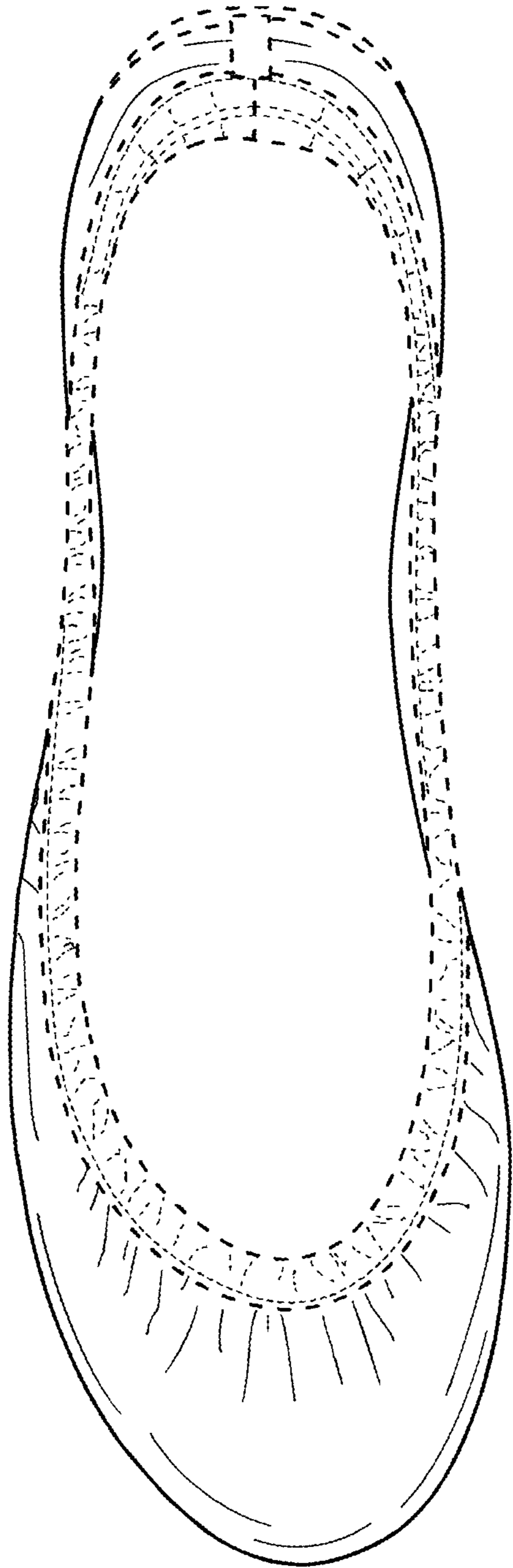

FIG. 39

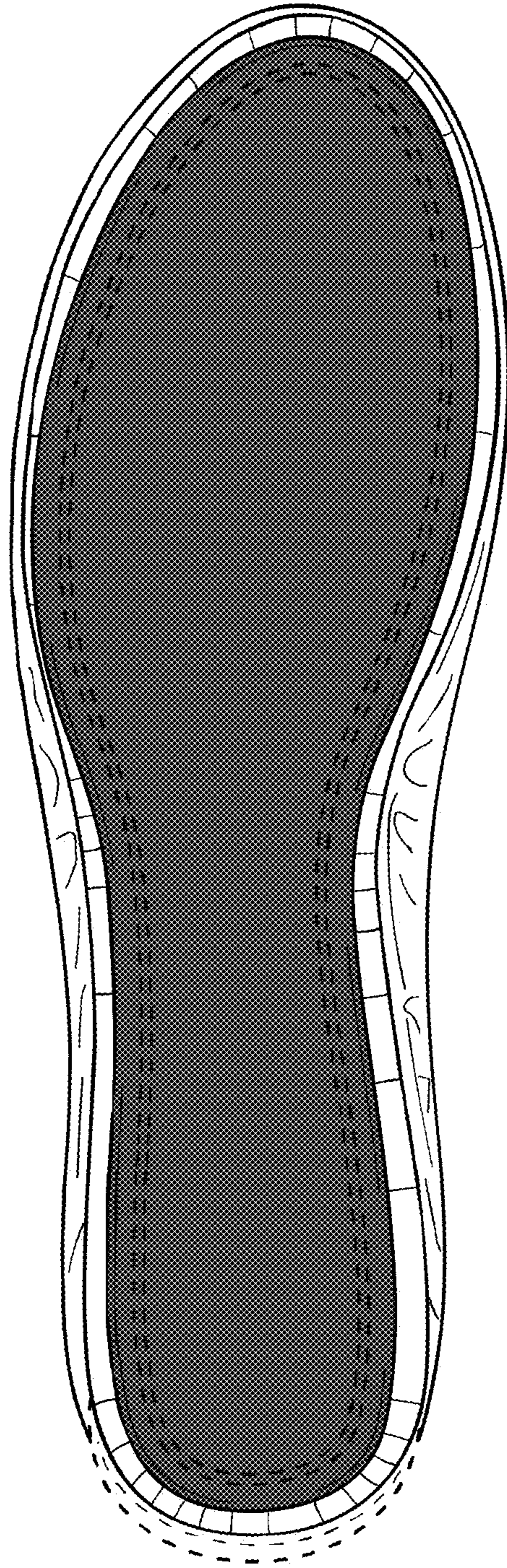

FIG. 40



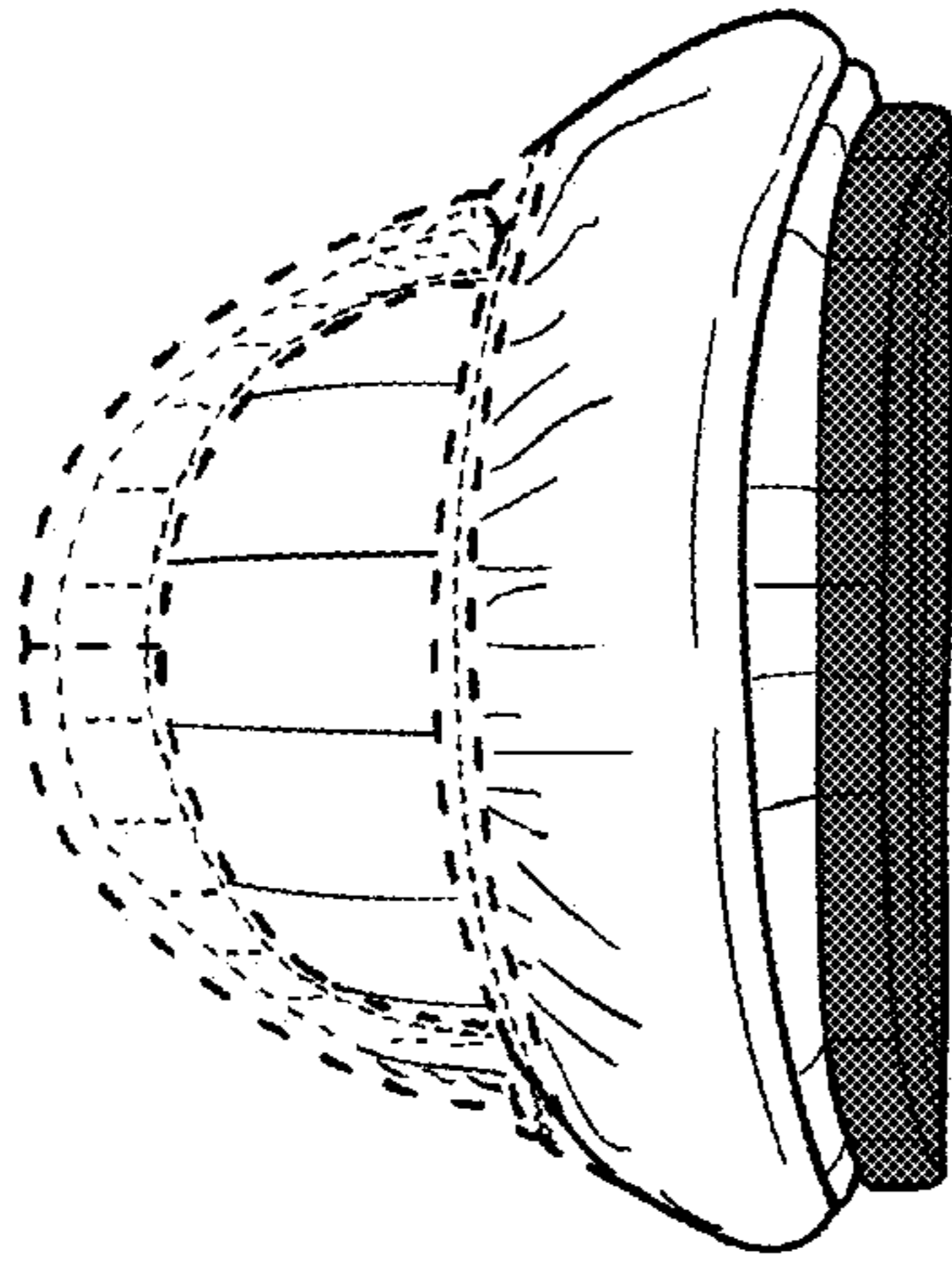

FIG. 41

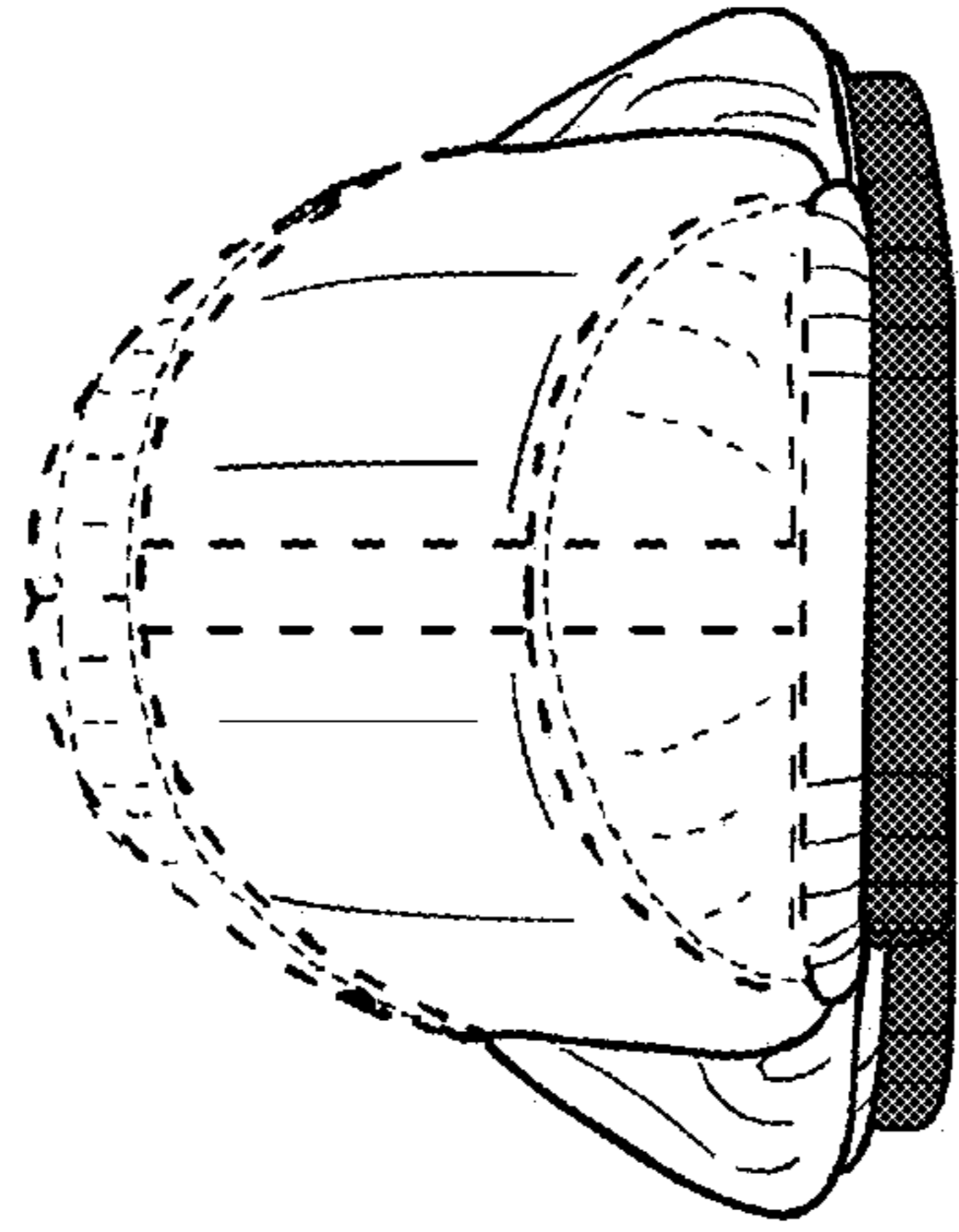

FIG. 42