

US00D901125S

(12) **United States Design Patent** (10) **Patent No.:** **US D901,125 S**  
**Tsukii** (45) **Date of Patent:** **\*\* Nov. 3, 2020**

(54) **MAIL BOX WITH AIRPLANE WHEEL PANTS**

(71) Applicant: **Toshikazu Tsukii**, Oro Valley, AZ (US)

(72) Inventor: **Toshikazu Tsukii**, Oro Valley, AZ (US)

(\*\*) Term: **15 Years**

(21) Appl. No.: **29/713,788**

(22) Filed: **Nov. 19, 2019**

**Related U.S. Application Data**

(62) Division of application No. 29/675,035, filed on Dec. 28, 2018, now Pat. No. Des. 878,004.

(51) **LOC (12) Cl.** ..... **99-00**

(52) **U.S. Cl.**  
USPC ..... **D99/32**

(58) **Field of Classification Search**  
USPC ..... D99/28, 29, 30, 31, 32, 43, 42, 99;  
312/35; 232/1 R, 1 A, 1 C, 1 D, 4 R, 2,  
232/17, 19, 20, 21, 22, 24, 27, 30, 31, 37,  
232/38, 39, 44, 45; D21/430, 447  
CPC ..... A47G 29/12; A47G 29/1201; A47G  
29/1203; A47G 29/1205; A47G 29/1207;  
A47G 29/1209; A47G 29/121; A47G  
29/1212; A47G 29/1214; A47G 29/1216;  
A47G 29/1218; A47G 29/122; A47G  
29/1225; A47G 29/16; A47G 29/00  
See application file for complete search history.

(56) **References Cited**

**U.S. PATENT DOCUMENTS**

D74,296 S \* 1/1928 Cameron ..... D99/30  
D77,464 S \* 1/1929 Cooper ..... D99/30  
D177,176 S \* 3/1956 Hege ..... D22/126  
3,397,481 A \* 8/1968 Boese ..... A63H 27/005  
446/52

3,888,409 A \* 6/1975 Bolduc ..... A47G 29/1205  
232/1 C  
3,960,317 A \* 6/1976 Clement ..... A47G 29/121  
232/35  
4,244,512 A \* 1/1981 Wise ..... A47G 29/1209  
232/17  
D301,929 S \* 6/1989 Evans ..... D21/699  
D319,421 S \* 8/1991 Kerezman ..... D12/126

(Continued)

*Primary Examiner* — Elizabeth J Oswecki

(74) *Attorney, Agent, or Firm* — Eugene Vamos

(57) **CLAIM**

The ornamental design for a mail box with airplane wheel pants, as shown and described.

**DESCRIPTION**

FIG. 1 is a front left perspective view of a mail box with airplane wheel pants showing my new design, with a door in a closed position;  
FIG. 2 is a front elevation view thereof;  
FIG. 3 is a back elevation view thereof;  
FIG. 4 is a right side elevation view thereof;  
FIG. 5 is a left side elevation view thereof;  
FIG. 6 is a top plan view thereof;  
FIG. 7 is a bottom plan view thereof;  
FIG. 8 is a back left perspective view thereof;  
FIG. 9 is a front left perspective view of the mail box with airplane wheel pants with the door in an open position;  
FIG. 10 is a front elevation view thereof;  
FIG. 11 is a back elevation view thereof;  
FIG. 12 is a right side elevation view thereof;  
FIG. 13 is a left side elevation view thereof;  
FIG. 14 is a top plan view thereof;  
FIG. 15 is a bottom plan view thereof; and,  
FIG. 16 is a back left perspective view thereof.  
The broken lines are for environmental purposes only and form no part of the claimed design.

**1 Claim, 16 Drawing Sheets**

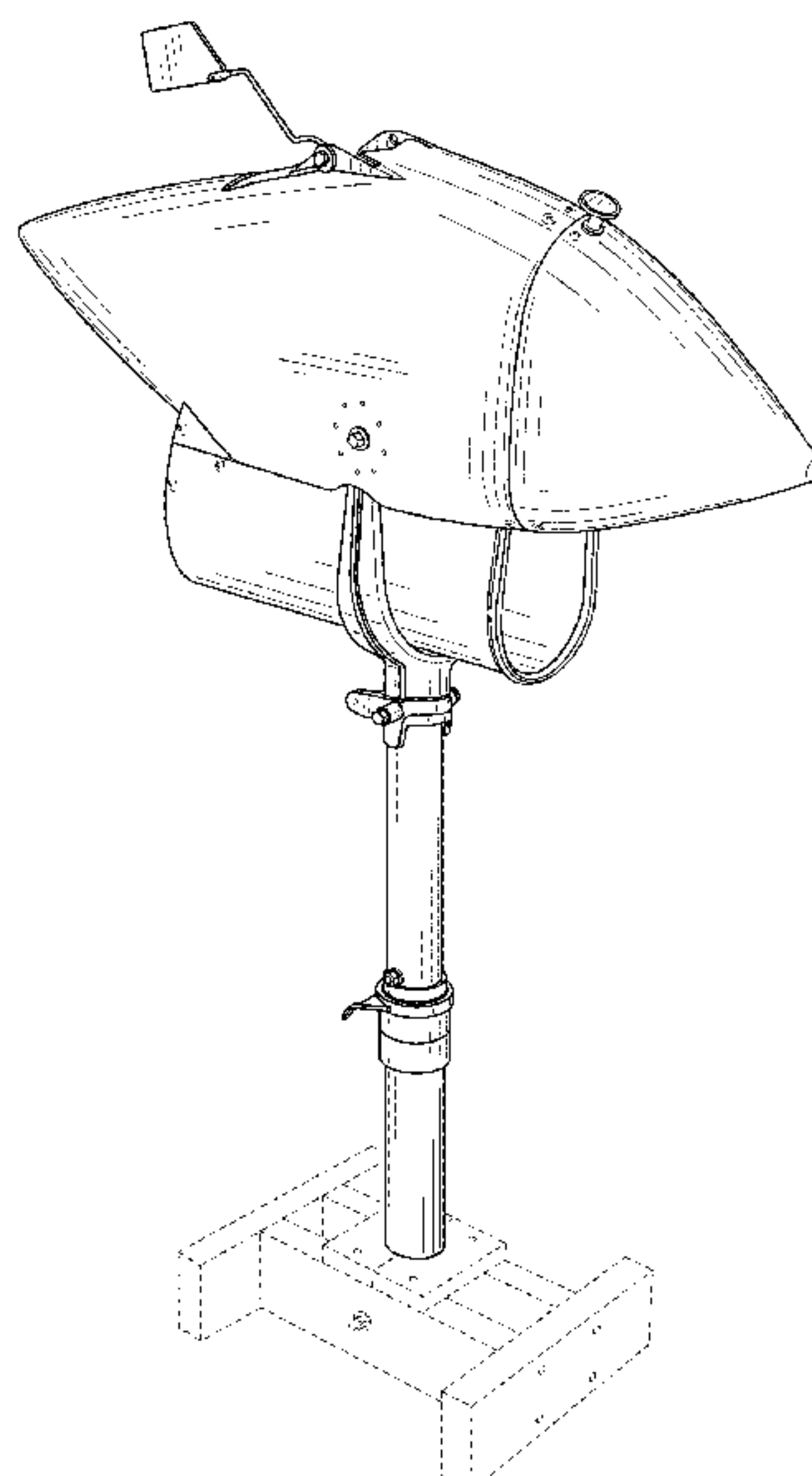

(56)

**References Cited**

U.S. PATENT DOCUMENTS

D335,755	S	*	5/1993	Davis .....	D99/32
D337,417	S	*	7/1993	McNiven .....	D99/32
D342,367	S	*	12/1993	Lamancusa .....	D99/30
D348,969	S	*	7/1994	Barbour .....	D99/30
D390,328	S	*	2/1998	Barton, Jr. ....	D99/29
5,950,918	A	*	9/1999	McDonough .....	A47G 29/1209
					232/17
D423,756	S	*	4/2000	Borer .....	D99/30
D439,723	S	*	3/2001	Avery .....	D99/30
D460,599	S	*	7/2002	Wrob .....	D99/30
D484,668	S	*	12/2003	Morgan .....	D99/29
D488,610	S	*	4/2004	Coleman .....	D99/30
D510,785	S	*	10/2005	King .....	D99/30
D548,925	S	*	8/2007	Haberman .....	D99/30
7,364,066	B1	*	4/2008	Wilson .....	A47G 29/1209
					232/17
D634,093	S	*	3/2011	Wagner .....	D99/30
D739,115	S	*	9/2015	Kelly .....	D99/32
D837,478	S	*	1/2019	Sanchez .....	D99/30
D878,004	S	*	3/2020	Tsukii .....	D99/30

\* cited by examiner

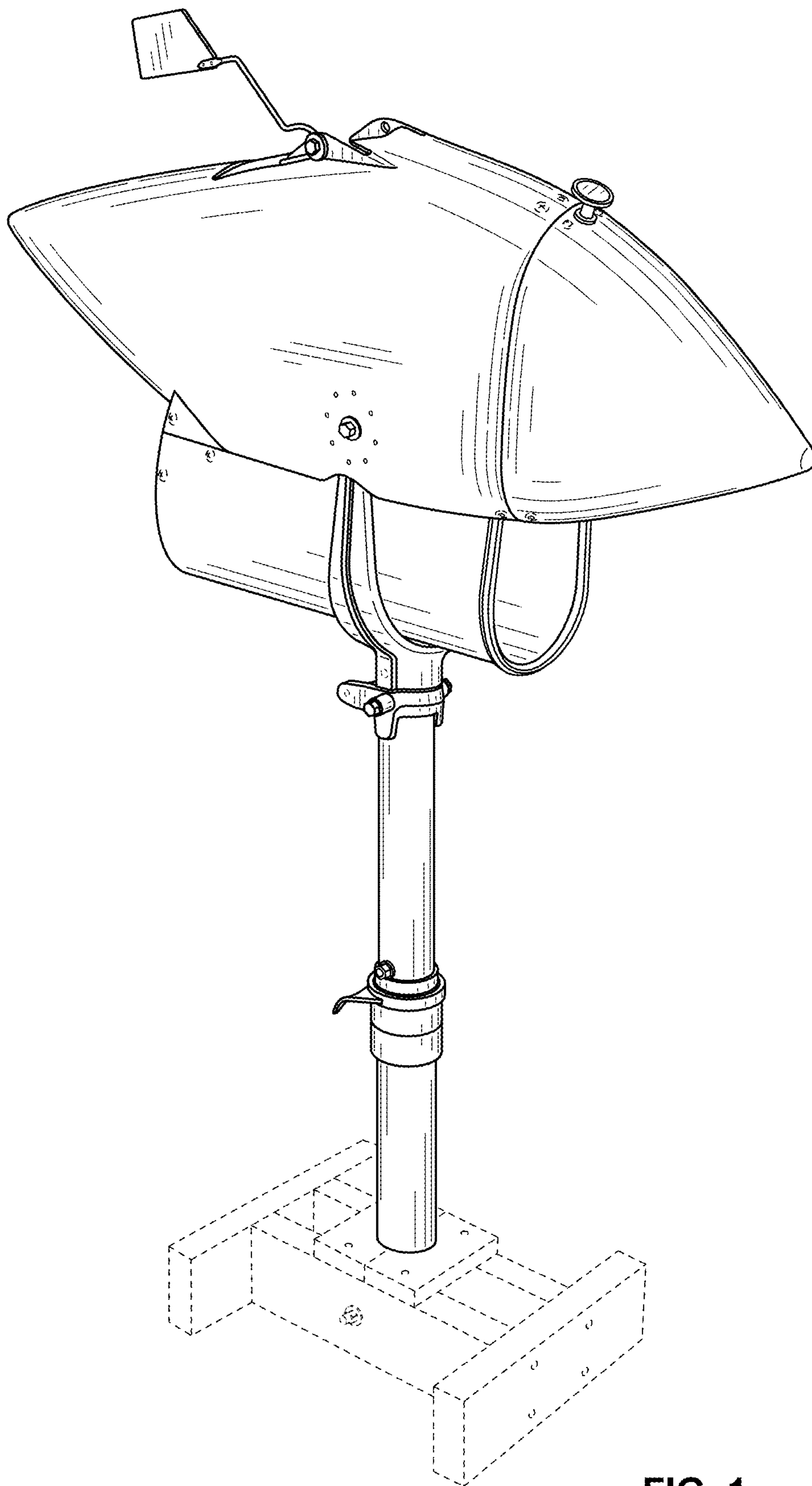

FIG. 1

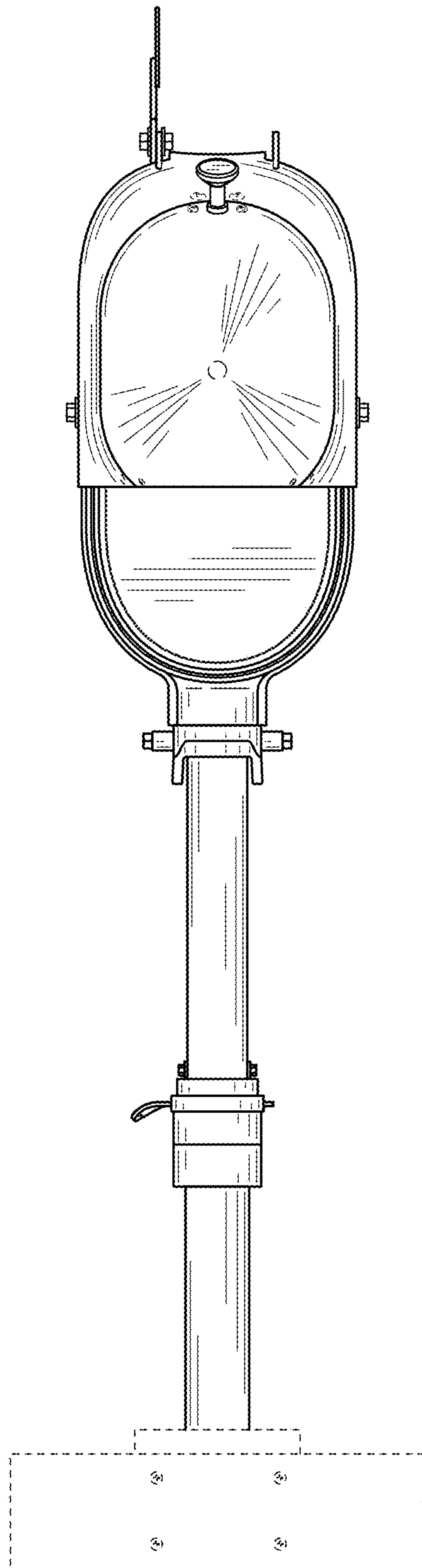

FIG. 2

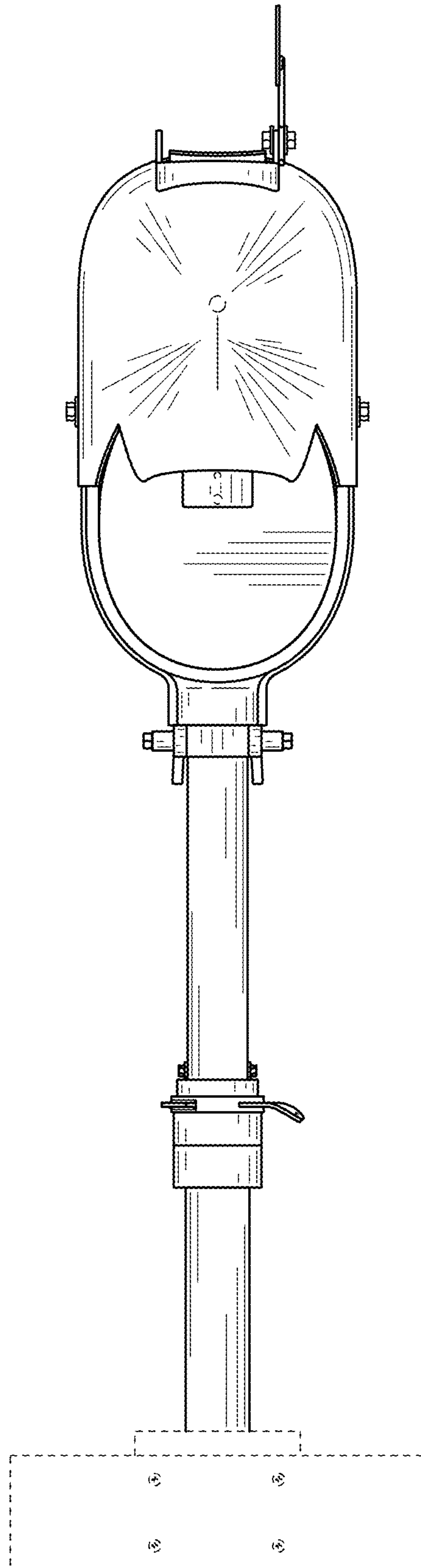

FIG. 3



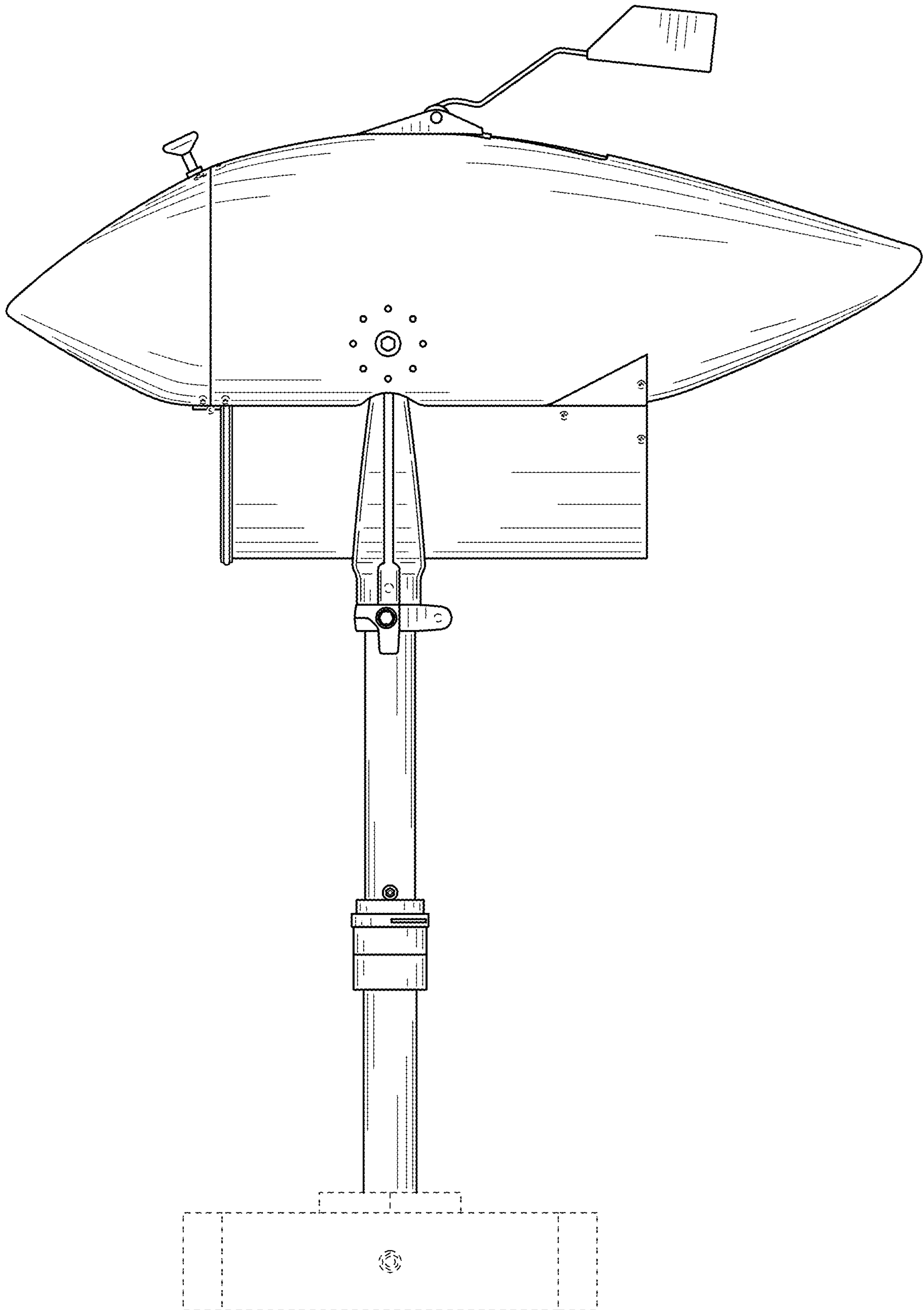

FIG. 4

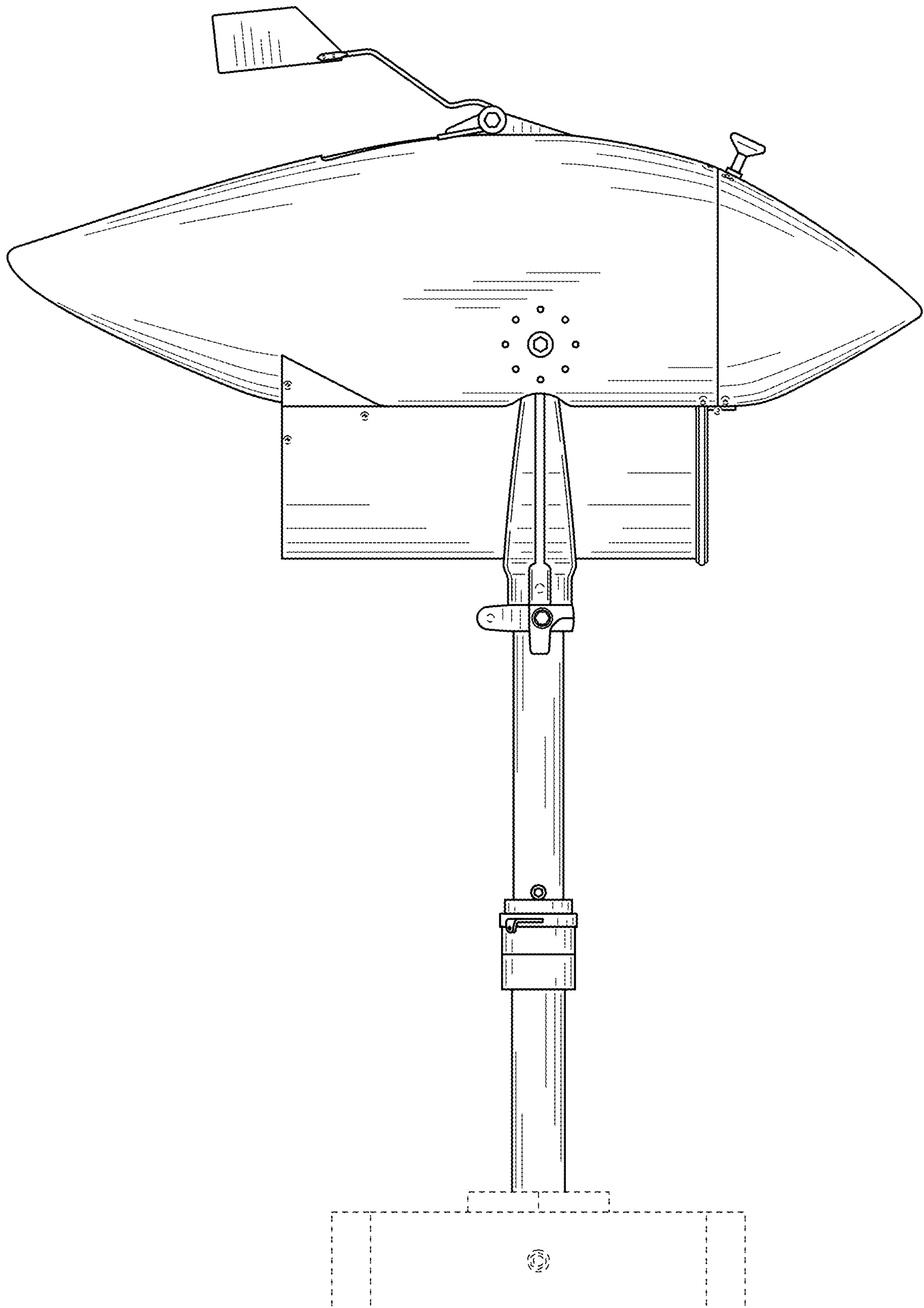

FIG. 5

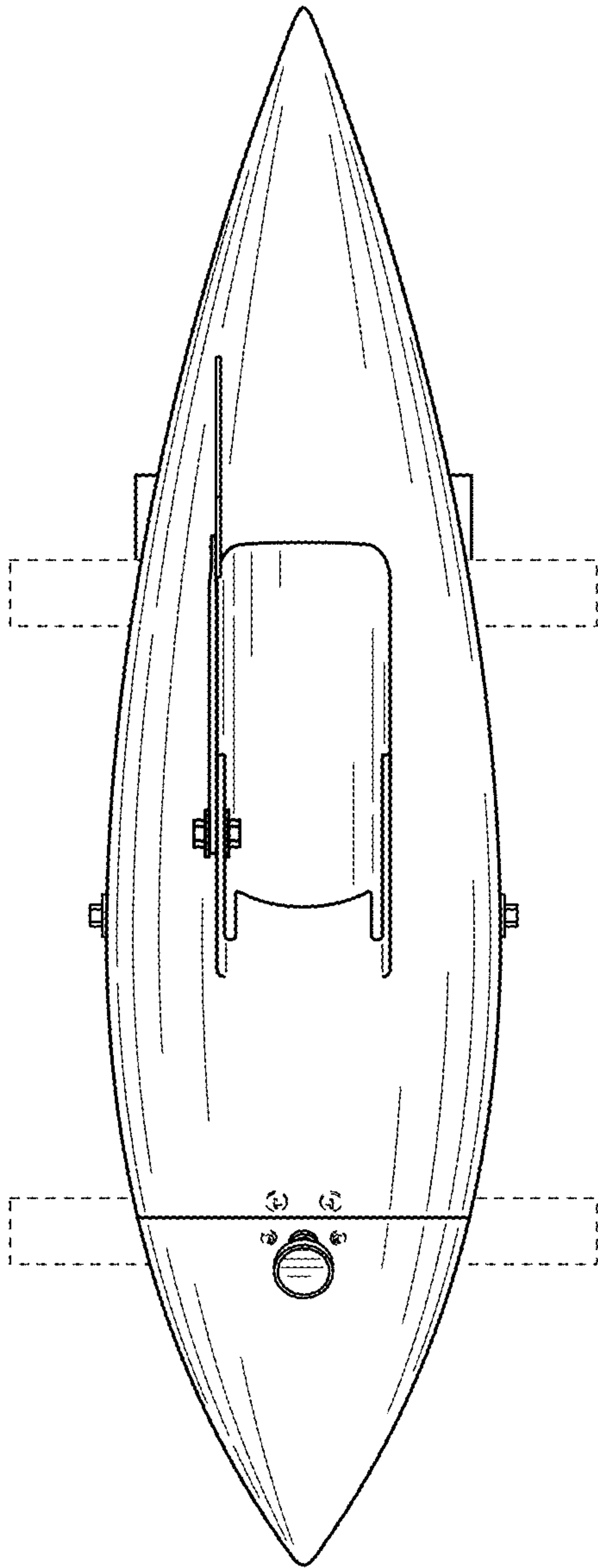

FIG. 6



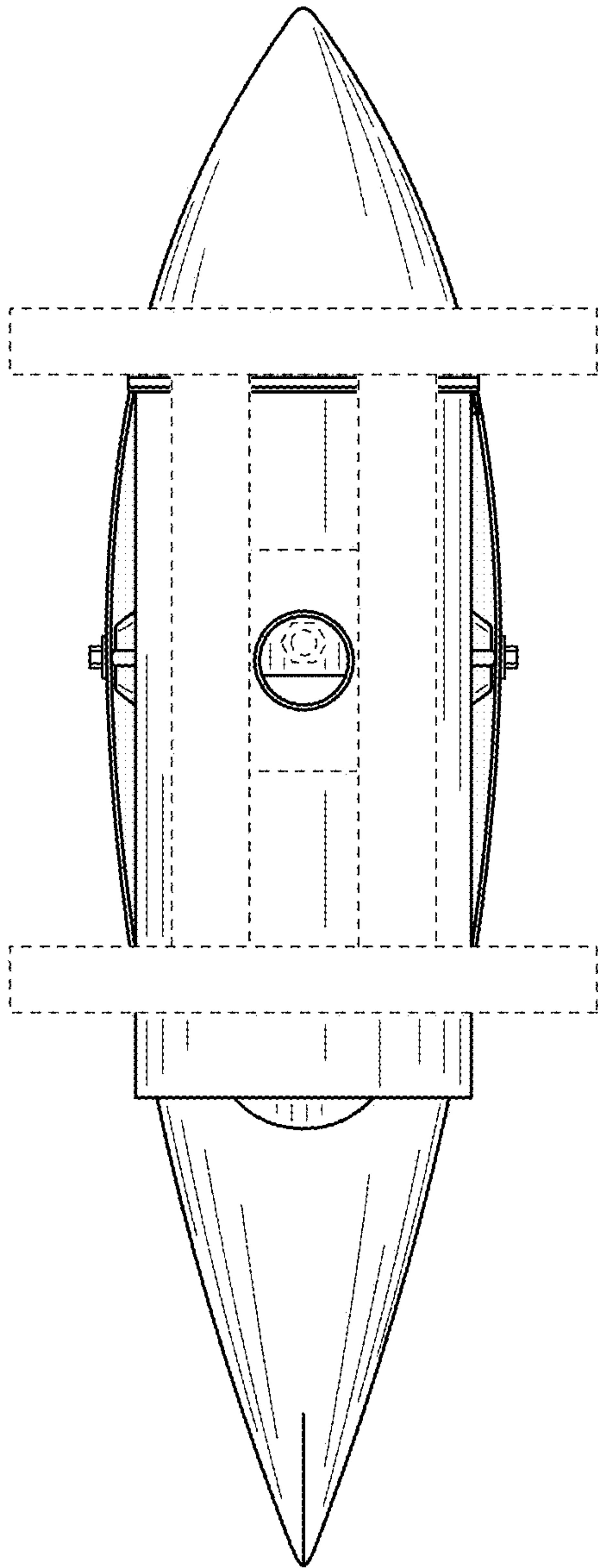

FIG. 7

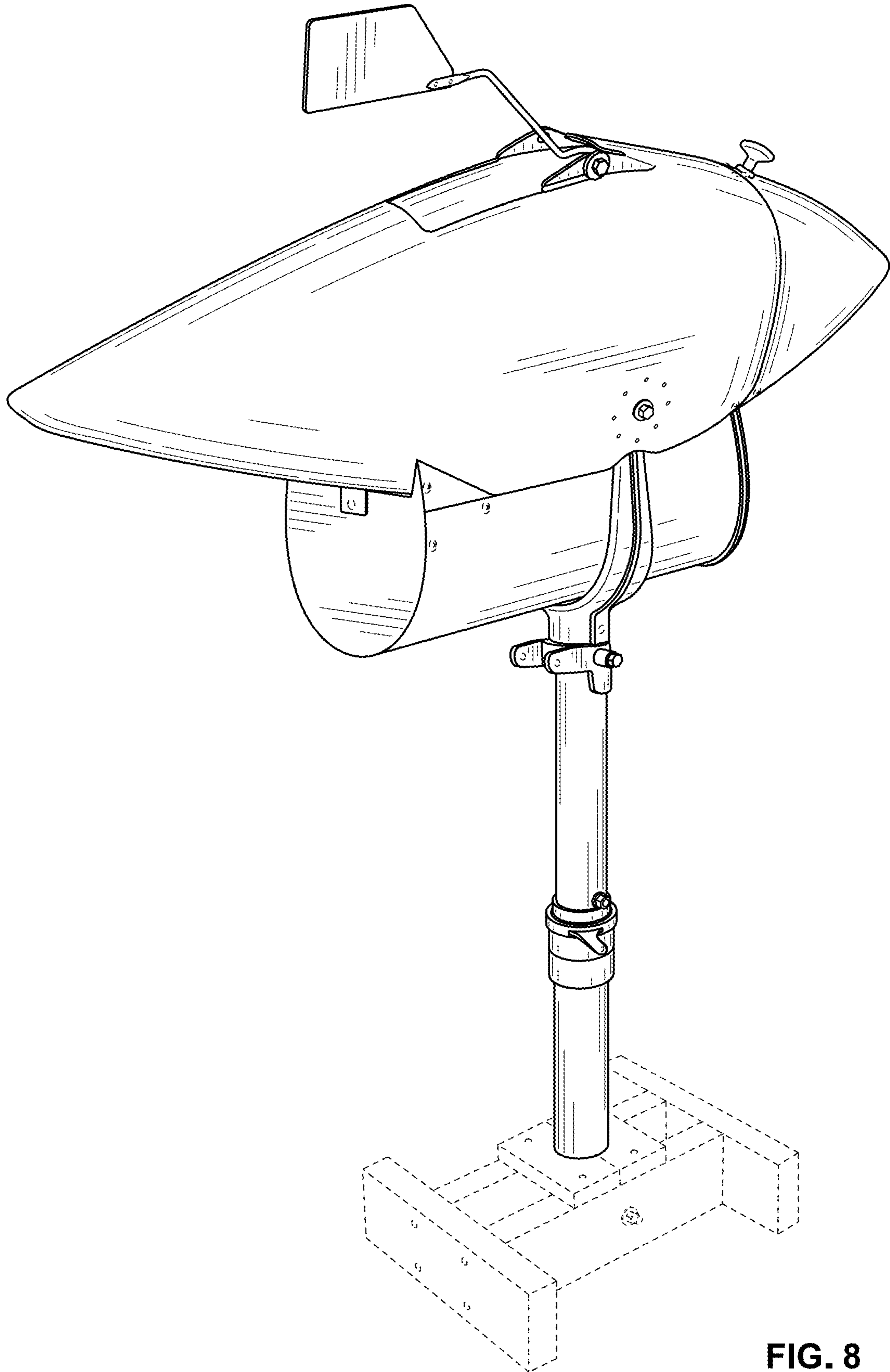

FIG. 8

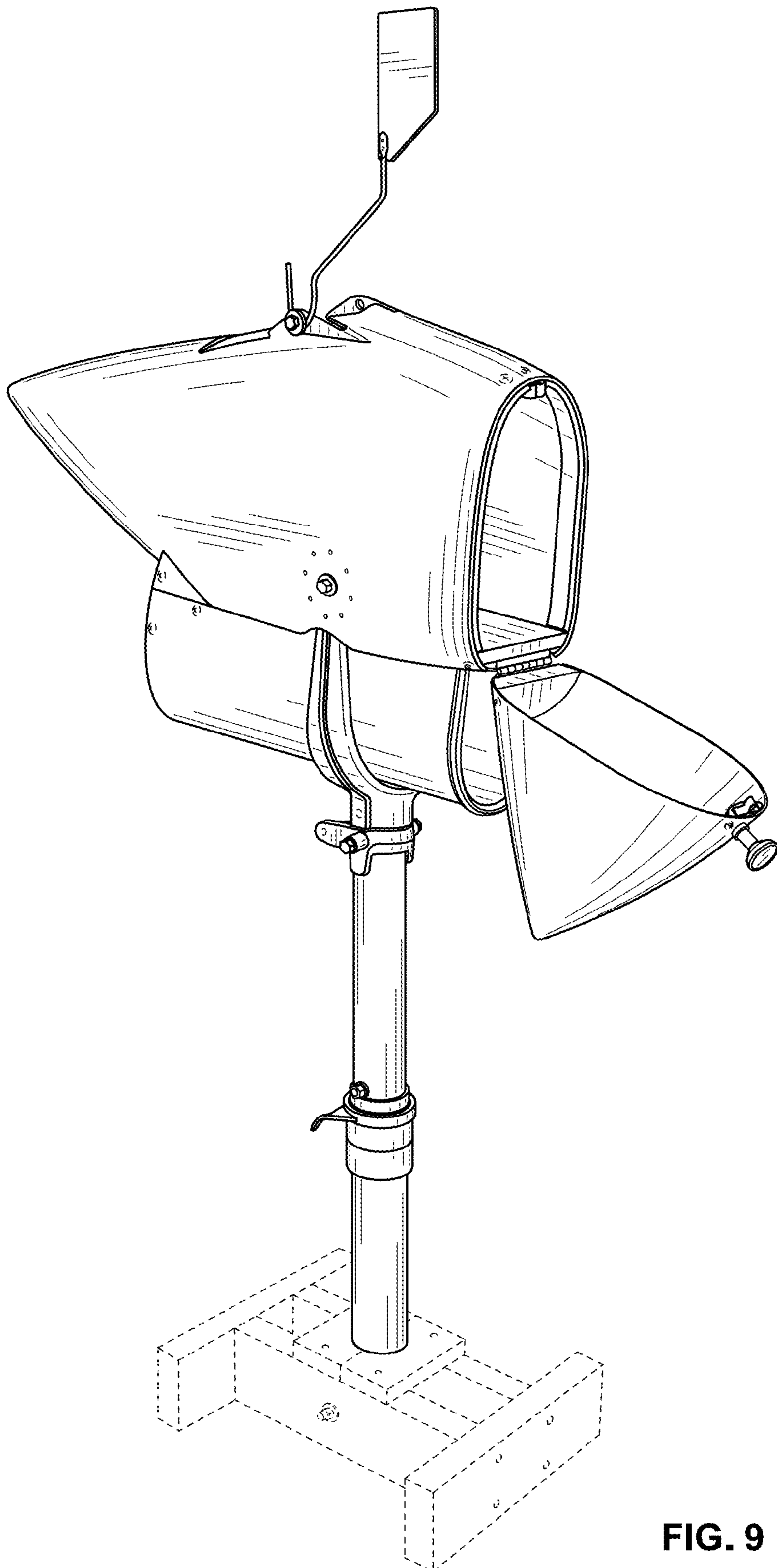

FIG. 9

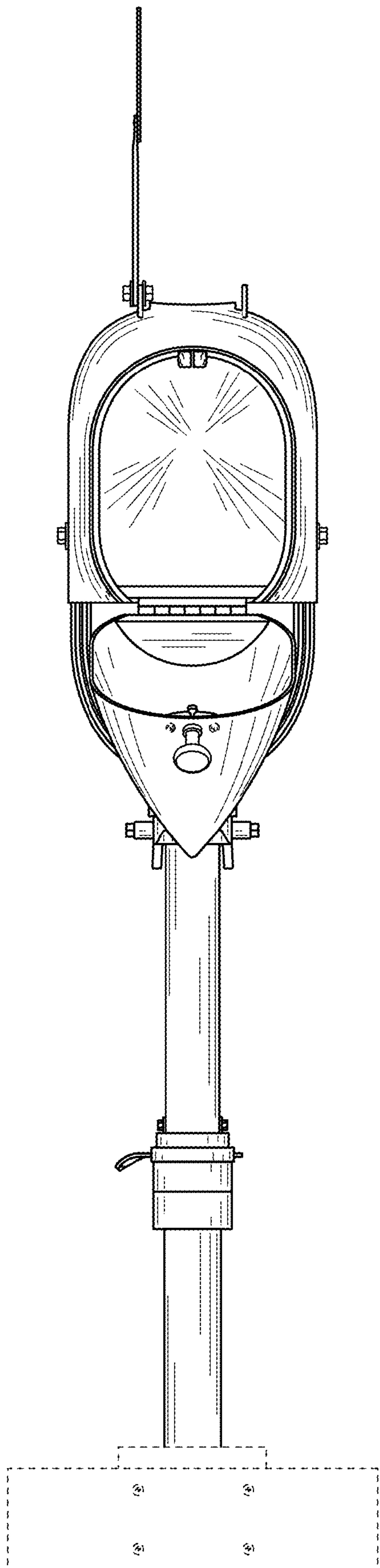

FIG. 10

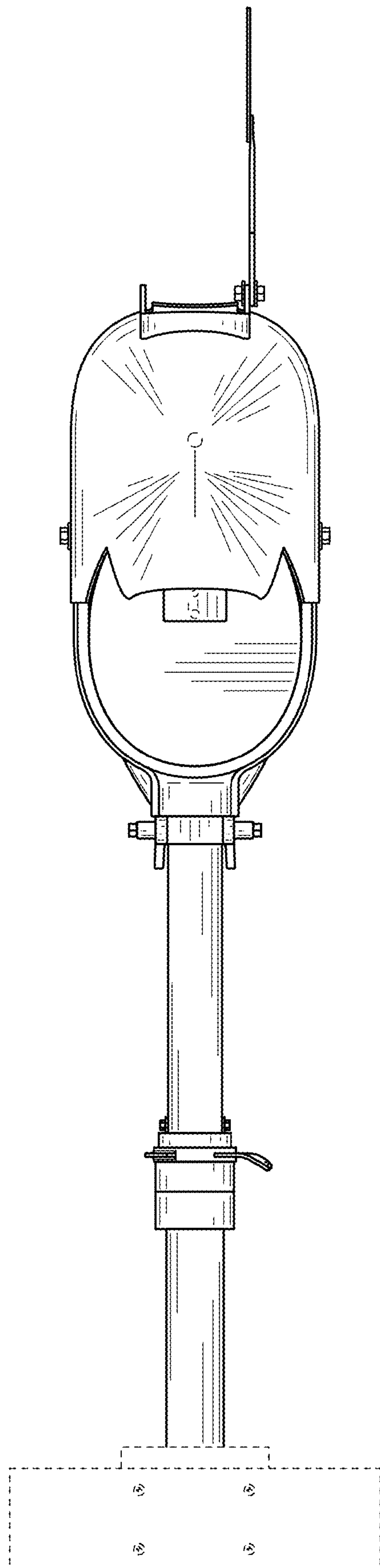

FIG. 11

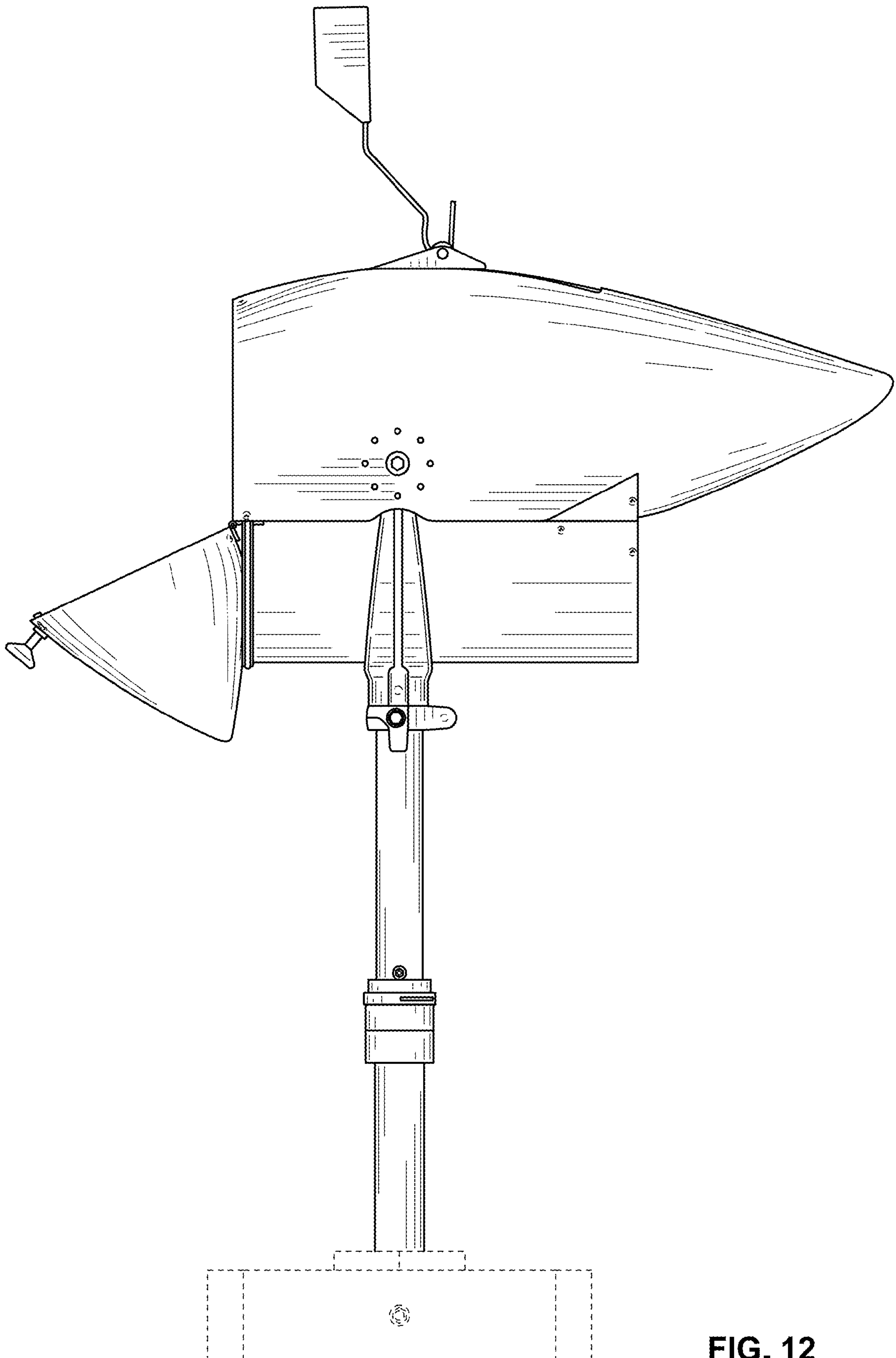

FIG. 12



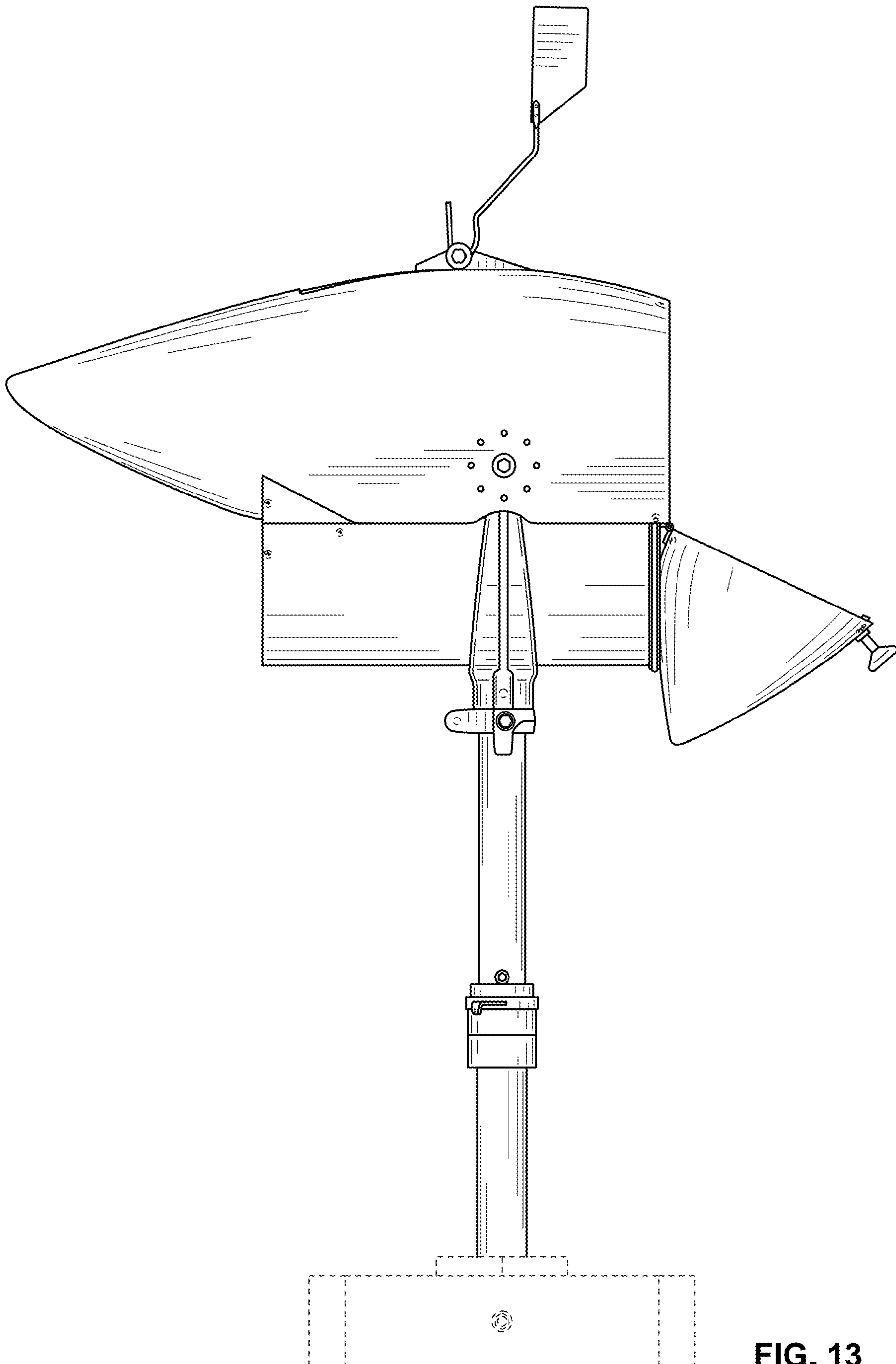

FIG. 13

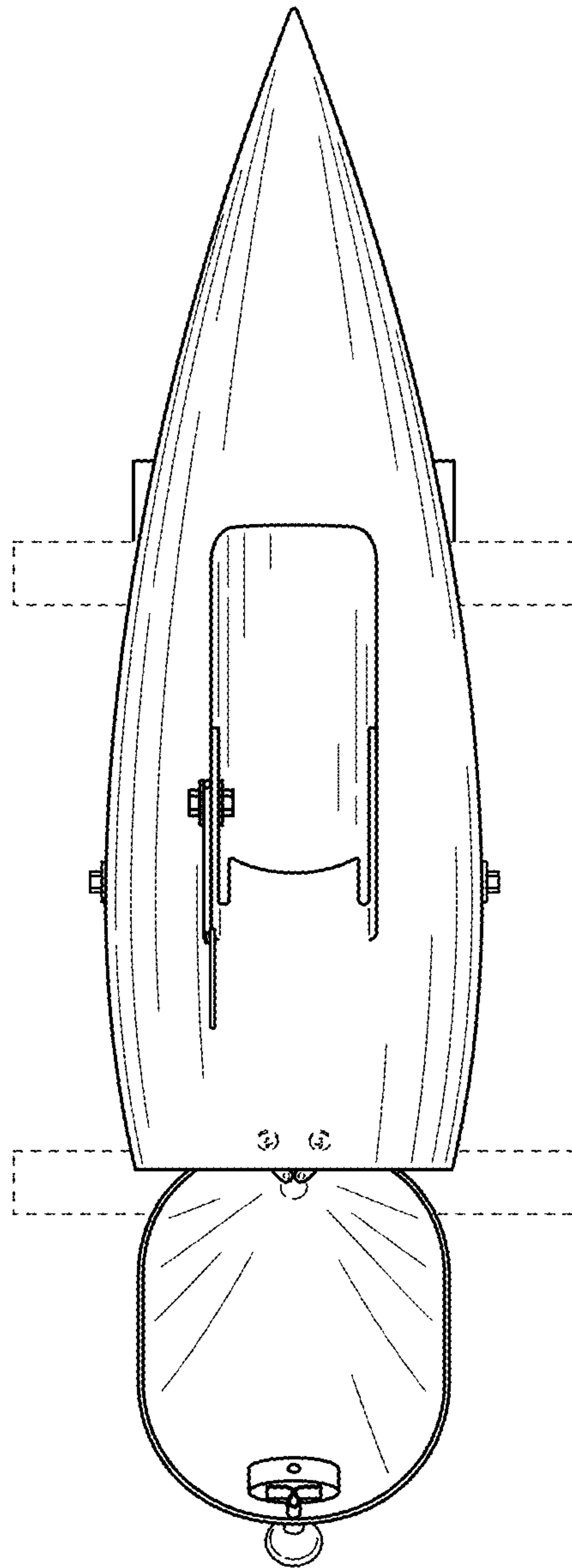

FIG. 14

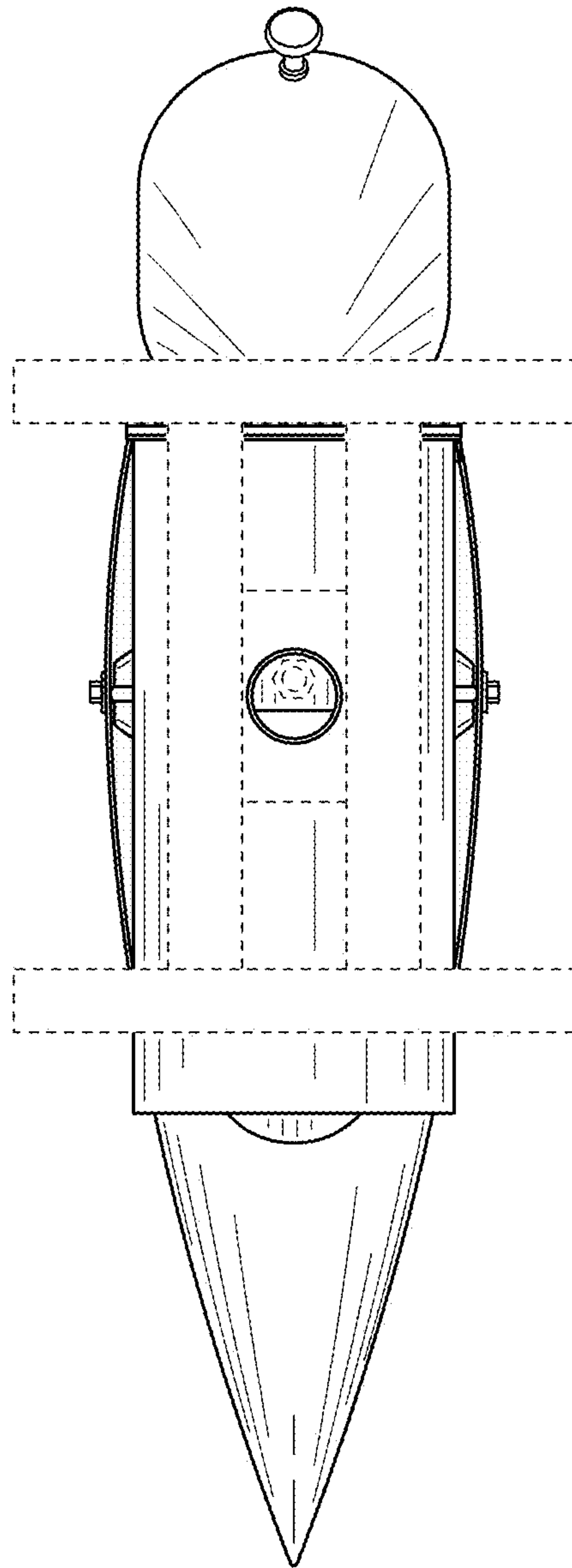

FIG. 15

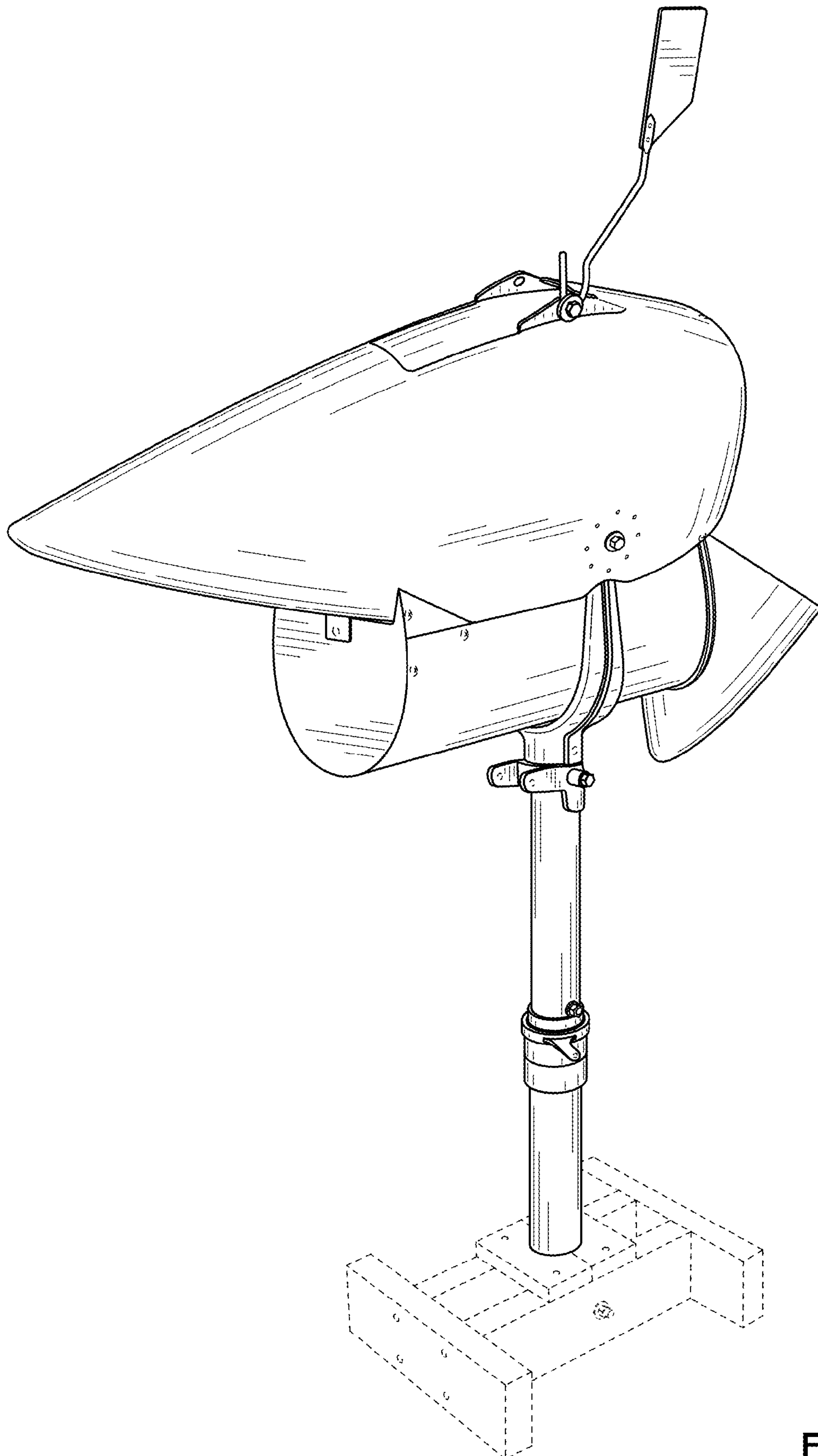

FIG. 16