



US00D900899S

(12) **United States Design Patent** (10) **Patent No.:** **US D900,899 S**
Mellor et al. (45) **Date of Patent:** **** Nov. 3, 2020**

(54) **FLOW PASSAGE CONTOURS FOR A HYDRAULIC MANIFOLD FOR ACTUATOR CONTROL WITH DUAL SOLENOIDS**

(71) Applicant: **The Boeing Company**, Chicago, IL (US)

(72) Inventors: **Mitchell L. R. Mellor**, Seattle, WA (US); **Jonathan B. Wallace**, Mount Vernon, WA (US)

(73) Assignee: **THE BOEING COMPANY**, Chicago, IL (US)

(**) Term: **15 Years**

(21) Appl. No.: **29/690,637**

(22) Filed: **May 9, 2019**

(51) **LOC (12) Cl.** **15-09**

(52) **U.S. Cl.**
USPC **D15/149**

(58) **Field of Classification Search**
USPC D15/5, 138, 148, 149; D23/245
CPC B64C 25/22; B64C 25/34; B64C 25/60;
F15B 15/16

See application file for complete search history.

(56) **References Cited**

U.S. PATENT DOCUMENTS

4,194,719 A * 3/1980 Ewald F15B 13/0433
137/625.64
4,357,955 A * 11/1982 Sauer F15B 13/02
137/270
4,941,508 A * 7/1990 Hennessy F16K 11/0708
137/625.69
5,372,060 A * 12/1994 Maruyama F15B 13/02
137/596.15
D406,320 S * 3/1999 Lynch D23/245
5,913,333 A * 6/1999 Biener F15B 13/0435
137/596.2

6,505,645 B1 * 1/2003 Pack F15B 13/0402
137/596.13
D520,520 S * 5/2006 Nimberger D15/5
D542,307 S * 5/2007 Stephenson D15/5
D557,281 S * 12/2007 Miller D15/5
D681,784 S * 5/2013 Liljegren D23/262
D745,112 S * 12/2015 Stevens D23/233
9,481,452 B2 11/2016 Lindahl et al.
9,764,827 B2 9/2017 Lindahl et al.
2004/0099316 A1 * 5/2004 Koetter F15B 13/0417
137/596.13
2005/0211320 A1 * 9/2005 Greenwood F15B 13/086
137/884
2011/0088236 A1 * 4/2011 Fathauer B23P 15/001
29/402.08

* cited by examiner

Primary Examiner — Patricia A Palasik

(74) *Attorney, Agent, or Firm* — Parsons Behle & Latimer

(57) **CLAIM**

The ornamental design for flow passage contours for a hydraulic manifold for actuator control with dual solenoids, as shown and described.

DESCRIPTION

FIG. 1 is a perspective view showing the top, front, and right sides of a supply boss for a hydraulic manifold for actuator control with dual solenoids showing the new design; FIG. 2 is a right side elevation view thereof; FIG. 3 is a left side elevation view thereof; FIG. 4 is a top side elevation view thereof; FIG. 5 is a bottom side elevation view thereof; FIG. 6 is a front side elevation view thereof; and, FIG. 7 is a back side elevation view thereof.

The evenly spaced broken lines depict portions of the manifold and environmental subject matter that forms no part of the claim. The dash-dot broken lines represent boundaries of the claim and form no part thereof.

1 Claim, 4 Drawing Sheets

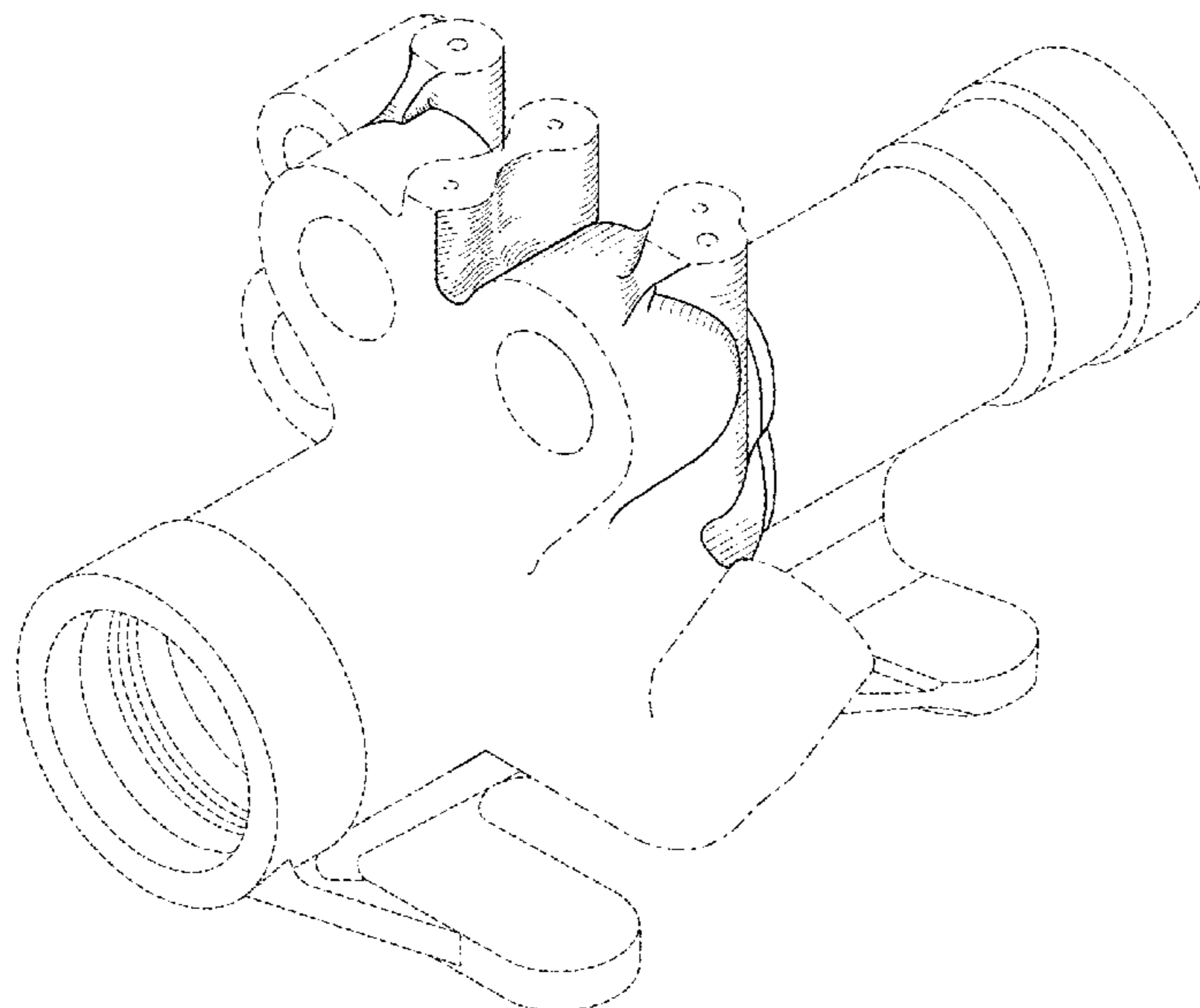

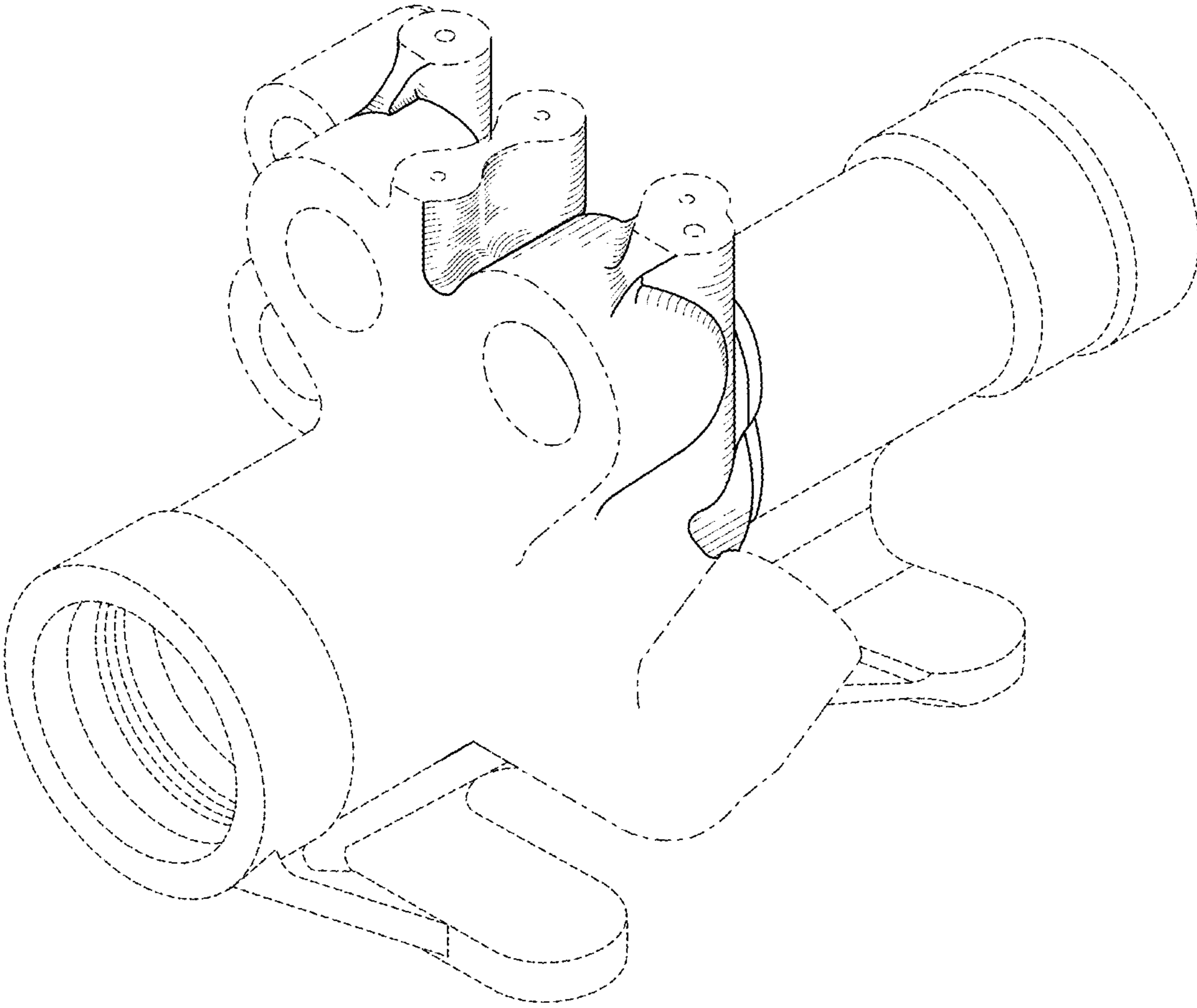

FIG. 1

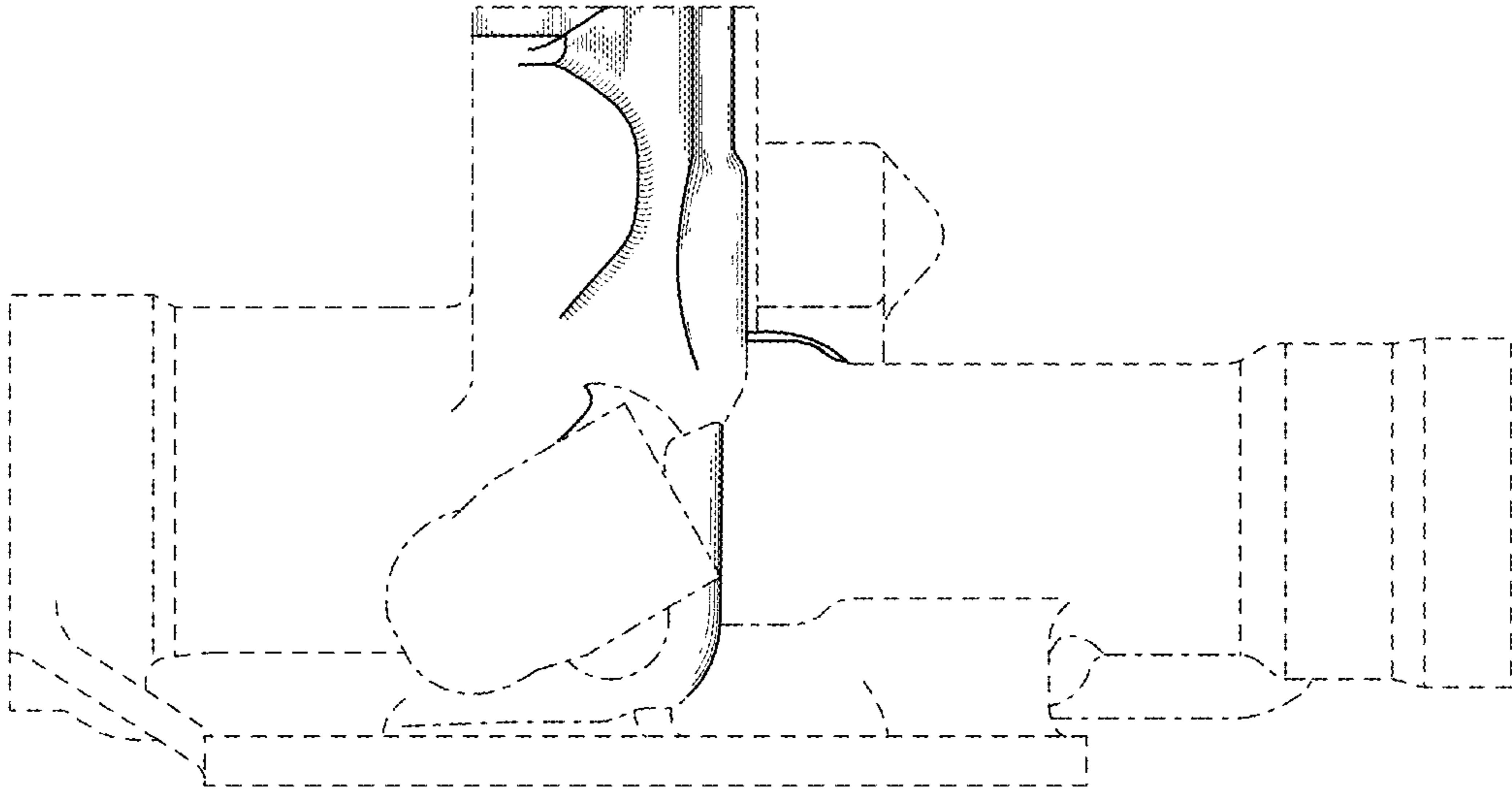

FIG. 2

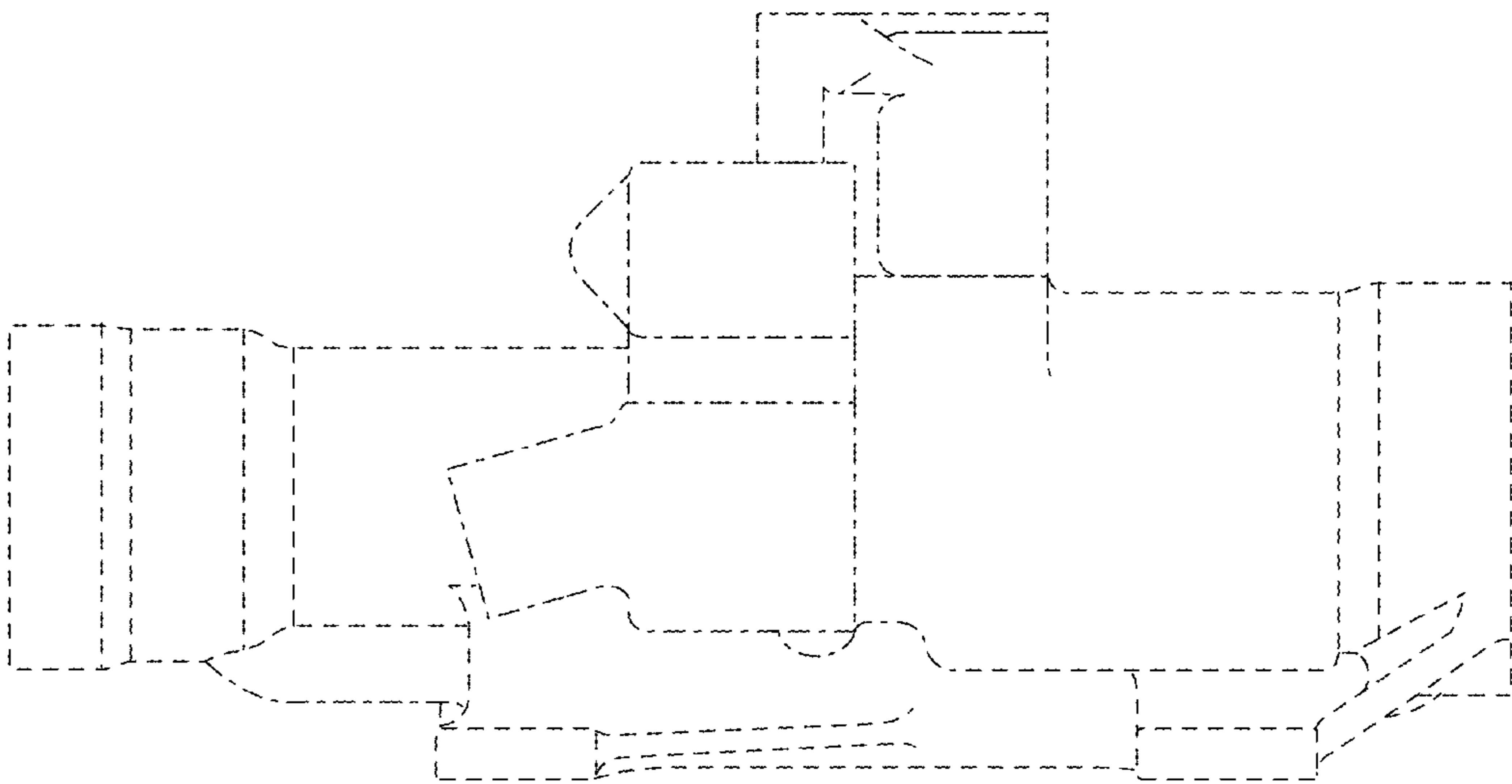

FIG. 3

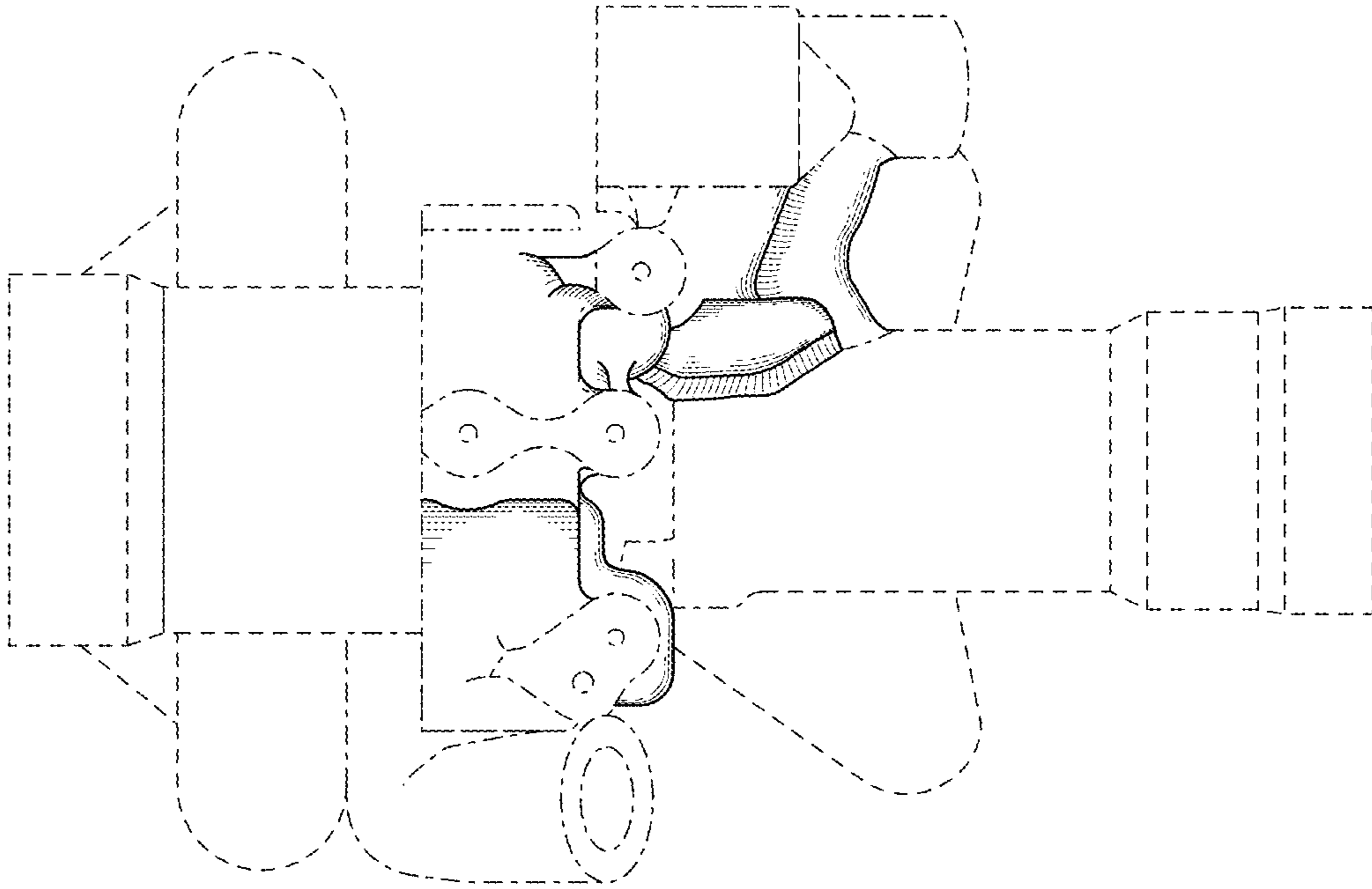

FIG. 4

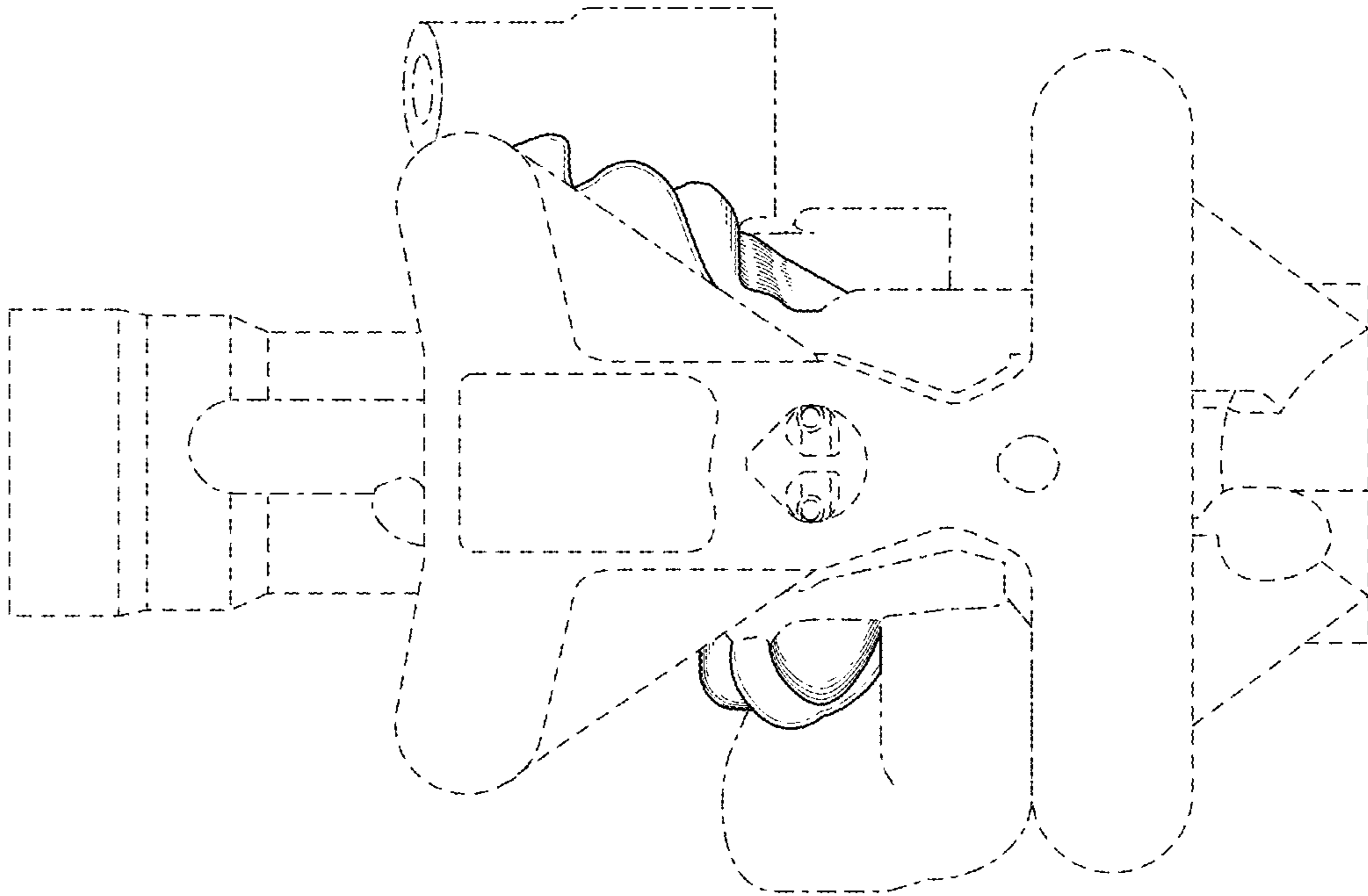

FIG. 5

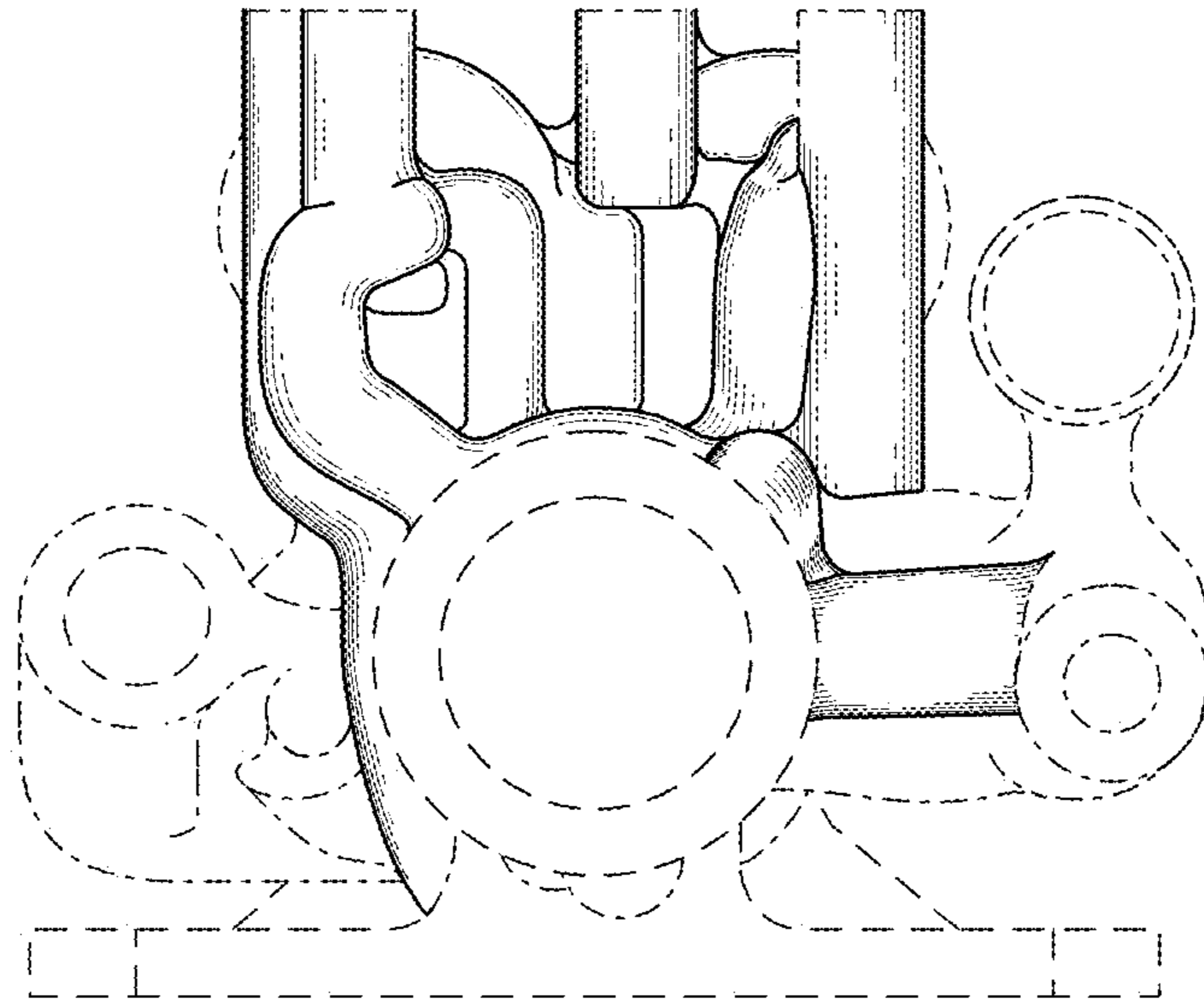

FIG. 6

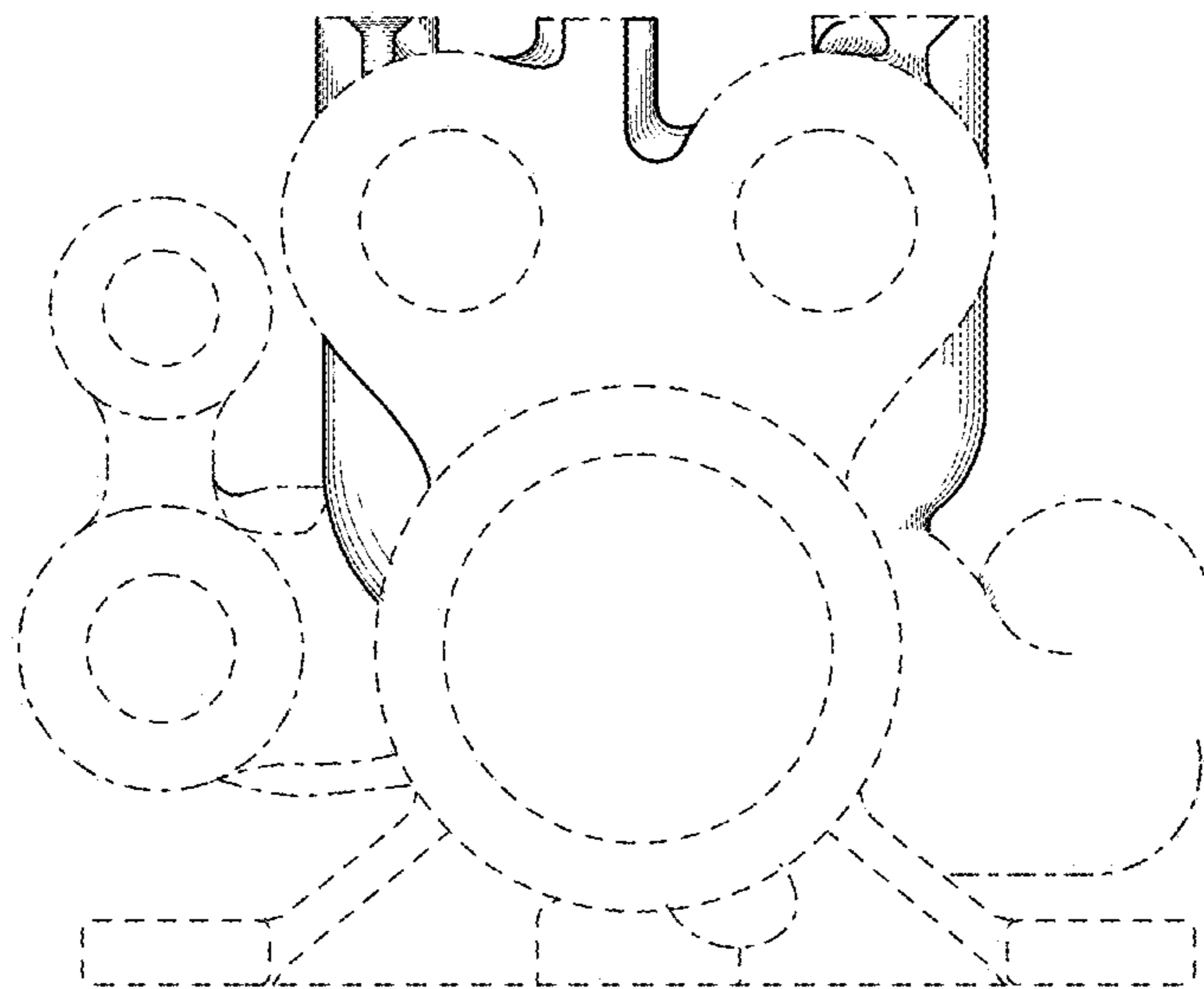

FIG. 7