



US00D900746S

(12) **United States Design Patent** (10) **Patent No.:** **US D900,746 S**  
**Kurita et al.** (45) **Date of Patent:** **\*\* Nov. 3, 2020**

(54) **ELECTRICAL CONNECTOR**  
 (71) Applicant: **SUMITOMO WIRING SYSTEMS, LTD.**, Yokkaichi-shi, Mie-ken (JP)  
 (72) Inventors: **Atsushi Kurita**, Yokkaichi (JP);  
**Masato Kamemura**, Yokkaichi (JP)  
 (73) Assignee: **SUMITOMO WIRING SYSTEMS, LTD.**, Yokkaichi-Shi, Mie-Ken (JP)

D578,065 S \* 10/2008 Baker ..... D13/133  
 D593,033 S \* 5/2009 Ogata ..... D13/133  
 D608,285 S \* 1/2010 Sato ..... D13/146  
 D651,172 S \* 12/2011 Yamauchi ..... D13/133  
 D814,418 S \* 4/2018 Kawakami ..... D13/133  
 D873,773 S \* 1/2020 Cao ..... D13/133  
 D873,774 S \* 1/2020 Cao ..... D13/133  
 D876,361 S \* 2/2020 Hu ..... D13/133

(\*\*) Term: **15 Years**

(21) Appl. No.: **29/698,271**

(22) Filed: **Jul. 16, 2019**

(30) **Foreign Application Priority Data**

Mar. 26, 2019 (JP) ..... 2019-006289

(51) **LOC (12) Cl.** ..... **13-03**

(52) **U.S. Cl.**  
 USPC ..... **D13/133**

(58) **Field of Classification Search**  
 USPC ..... D13/133, 146, 147, 153, 154, 155, 172,  
 D13/184

CPC ..... H01R 13/506; H01R 13/62; H01R 13/64;  
 H01R 13/641; H01R 4/24; H01R 4/48;  
 H01R 12/79; H01R 13/02; H01R 13/504;  
 H01R 13/436; H01R 13/502

See application file for complete search history.

(56) **References Cited**

**U.S. PATENT DOCUMENTS**

5,482,479 A \* 1/1996 Hayashi ..... H01R 13/4223  
 439/519  
 D574,773 S \* 8/2008 Sutter ..... D13/133

**FOREIGN PATENT DOCUMENTS**

JP 1411213 S 4/2011  
 JP 1618723 S 11/2018

\* cited by examiner

*Primary Examiner* — Karen E Kearney

*Assistant Examiner* — Michael Chong

(74) *Attorney, Agent, or Firm* — Grogan, Tuccillo & Vanderleeden, LLP

(57) **CLAIM**

The ornamental design for an electrical connector, as shown and described.

**DESCRIPTION**

FIG. 1 is a front, top and left side perspective view of an electrical connector showing our new design;  
 FIG. 2 is a front view thereof,  
 FIG. 3 is a rear view thereof;  
 FIG. 4 is a top plan view thereof;  
 FIG. 5 is a bottom plan view thereof;  
 FIG. 6 is a right side view thereof  
 FIG. 7 is a left side view thereof; and,  
 FIG. 8 is a cross-sectional view taken along line 8-8 in FIG. 6.

**1 Claim, 8 Drawing Sheets**

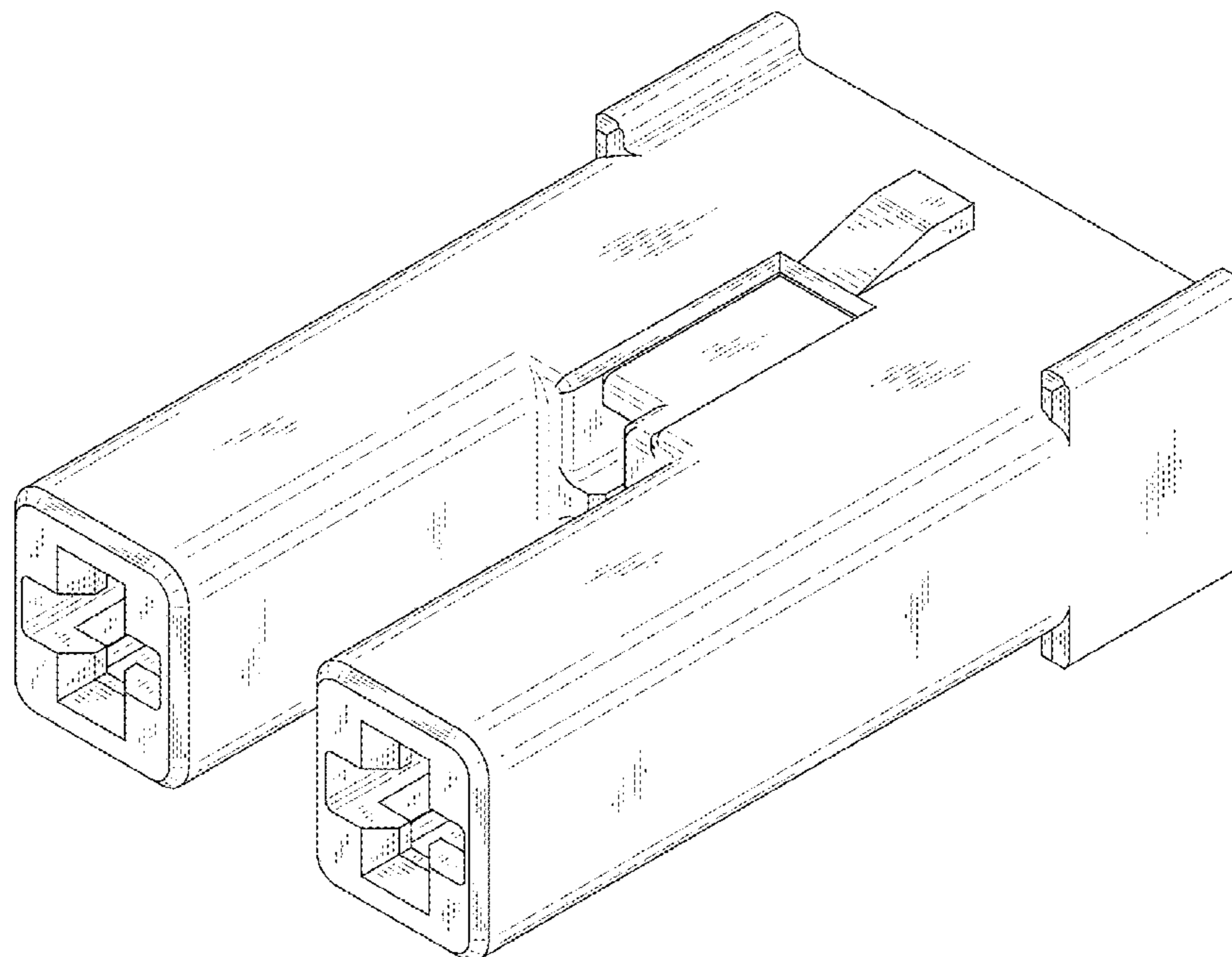

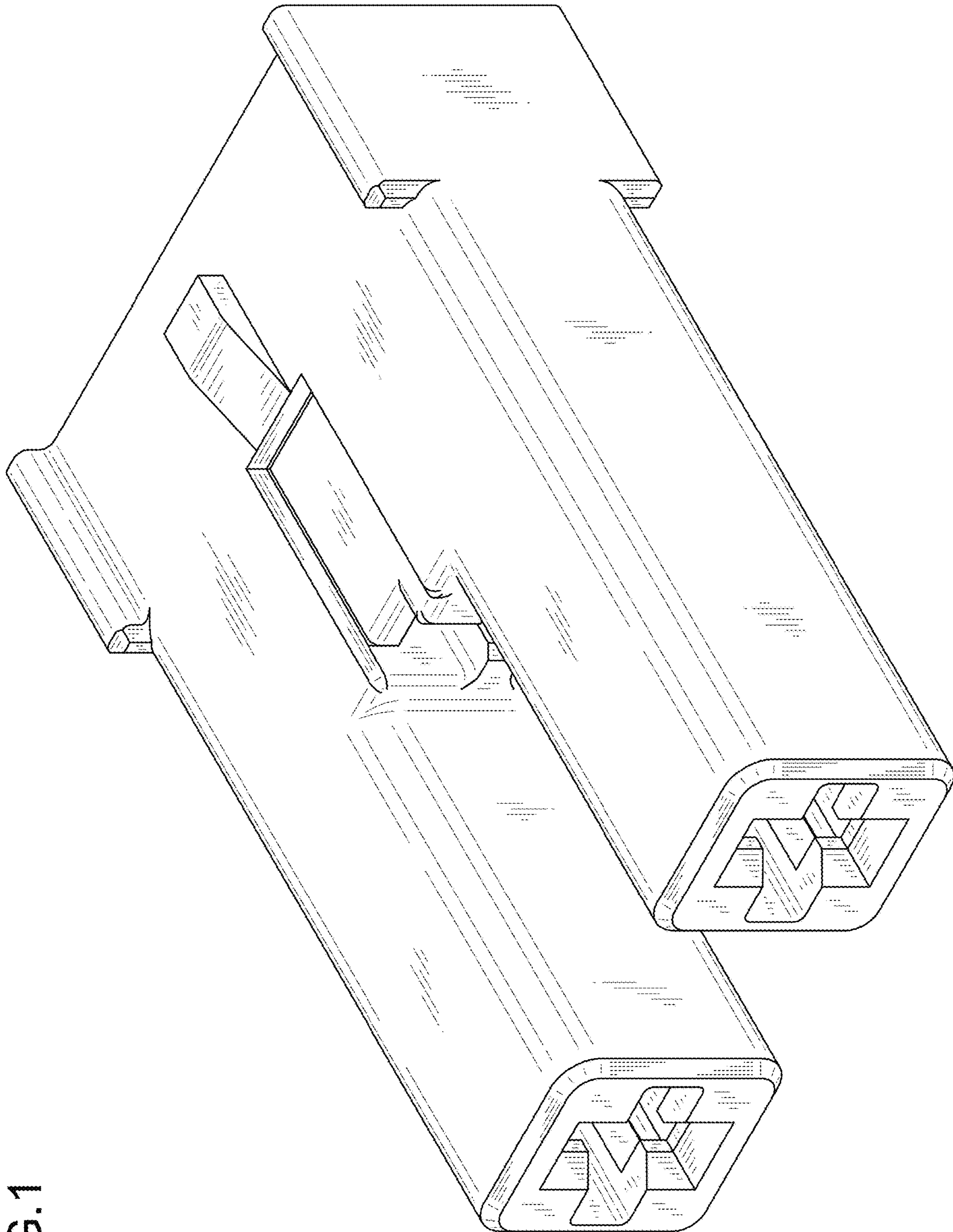

FIG.1

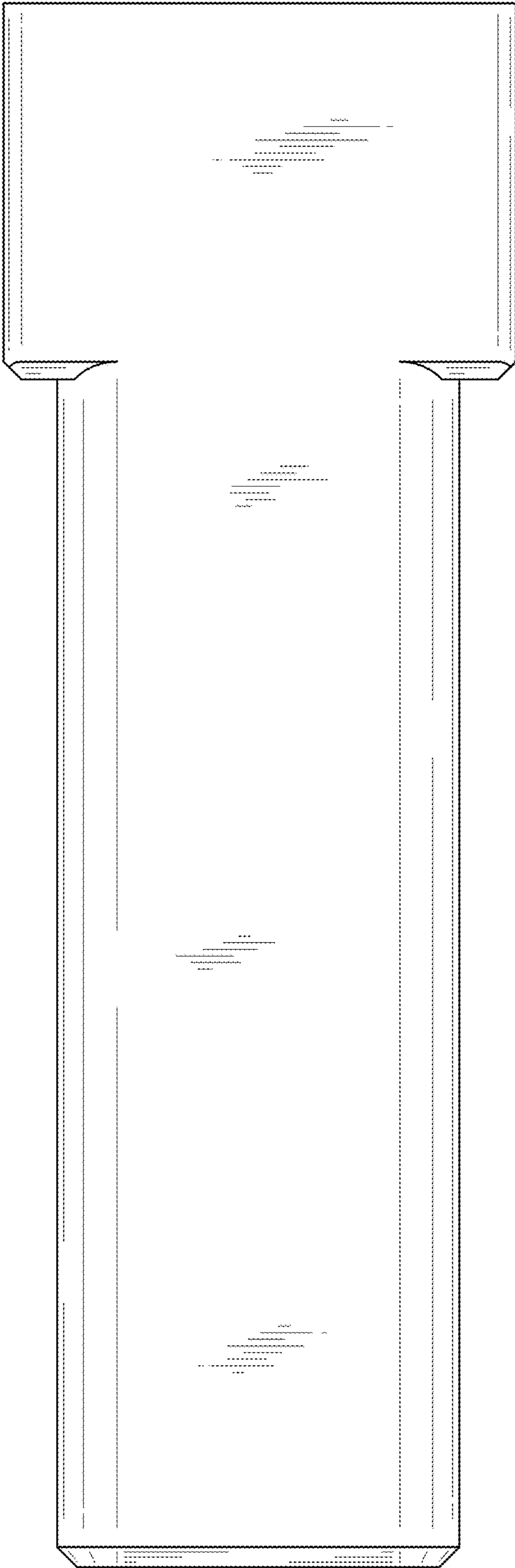

FIG.2

FIG.3

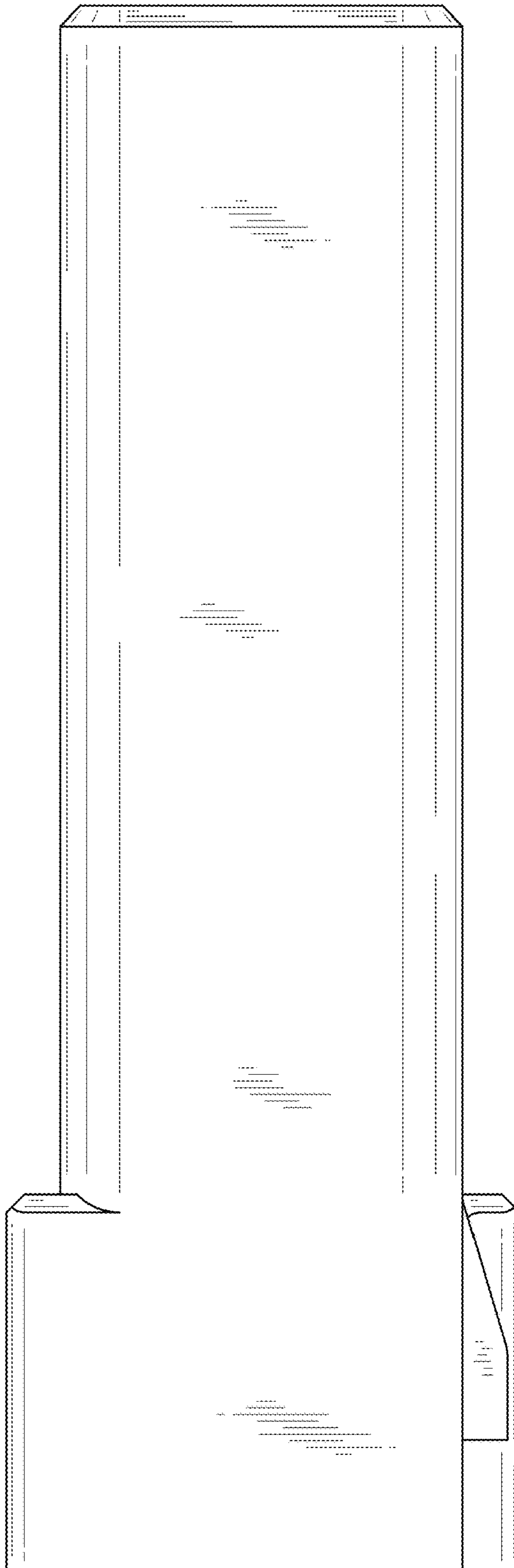

FIG.4

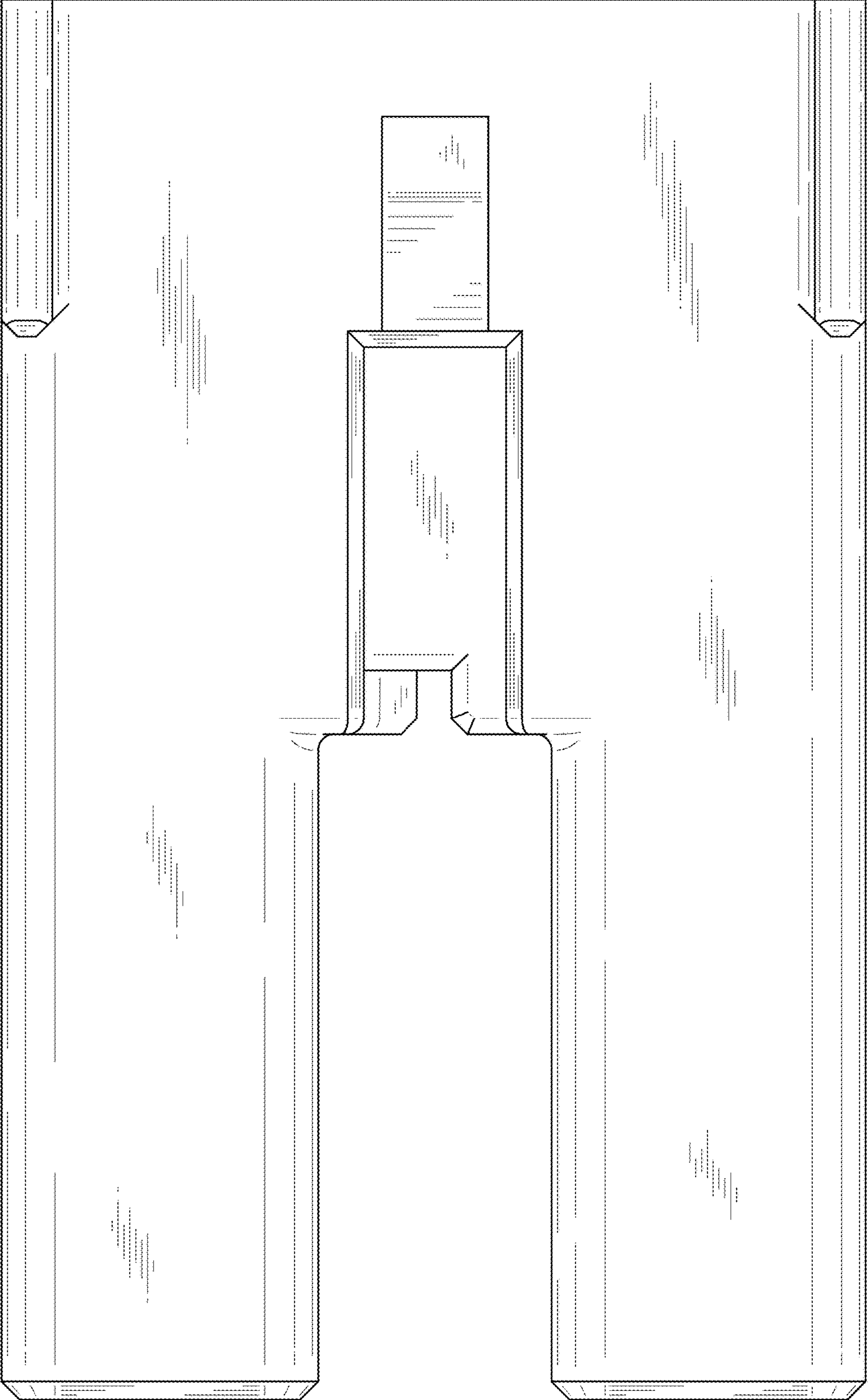
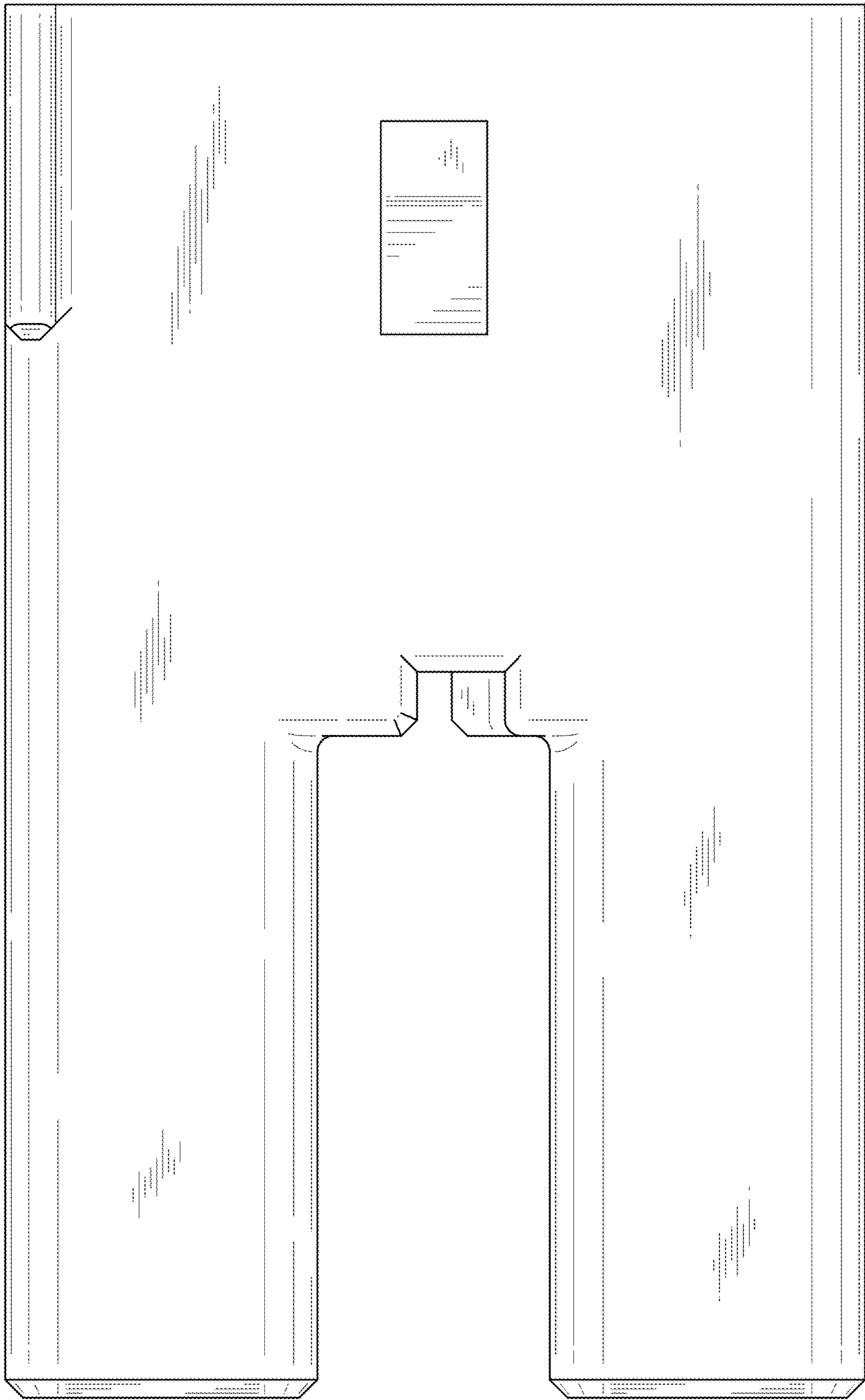

FIG.5



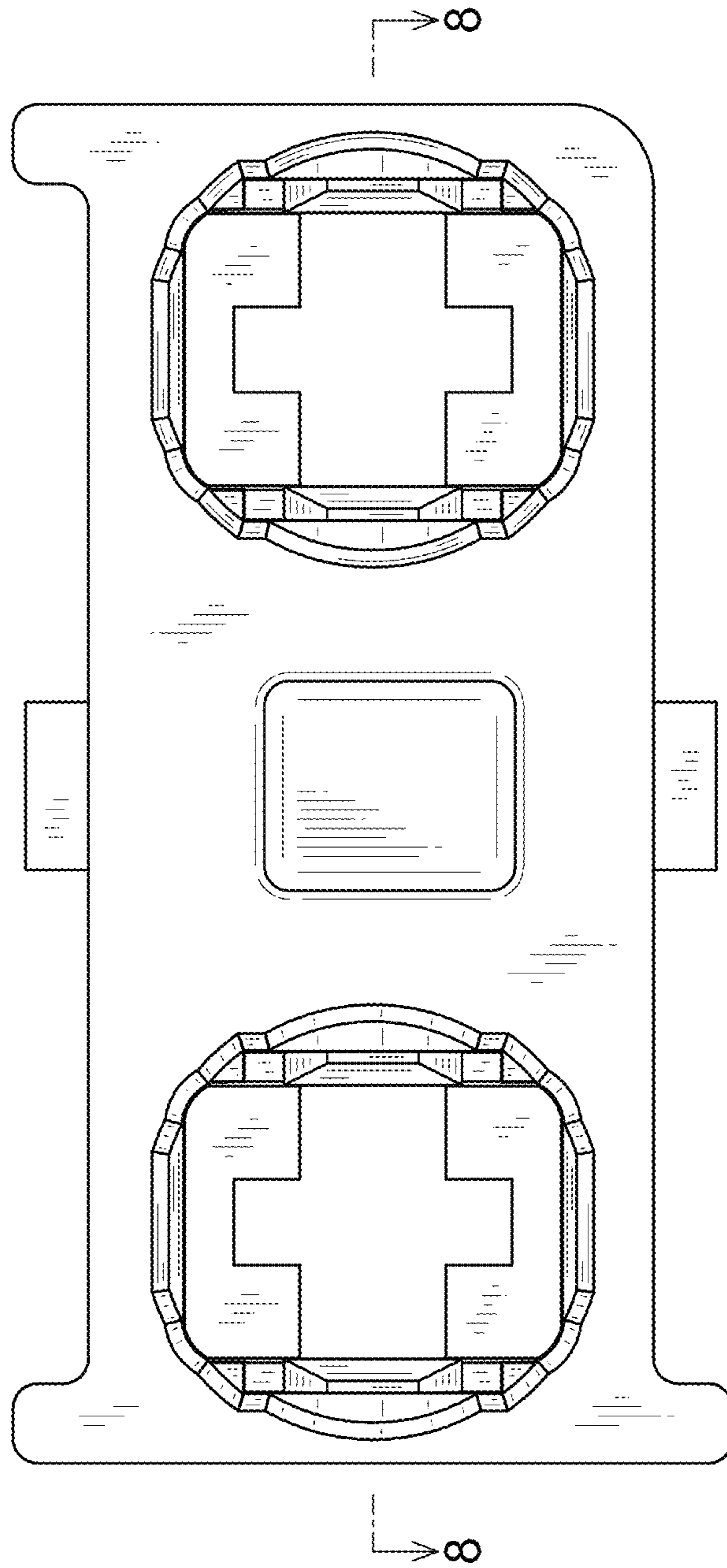

FIG.6

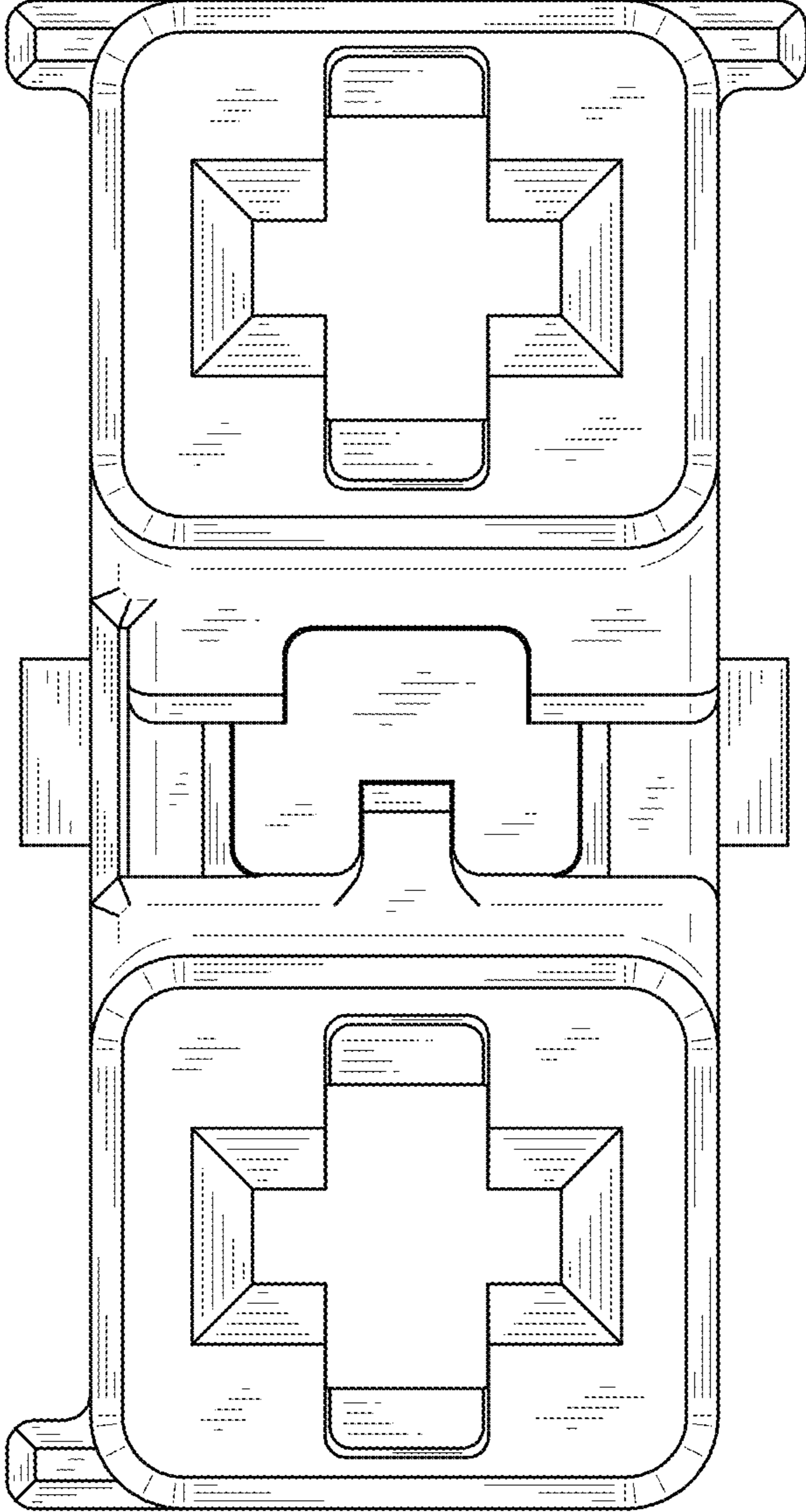

FIG.7



FIG.8

