



US00D900687S

(12) **United States Design Patent** (10) **Patent No.:** **US D900,687 S**
Lofton (45) **Date of Patent:** **** Nov. 3, 2020**

(54) **UNDERCARRIAGE WIND DEFLECTOR FOR SEMITRAILERS**

9,296,433 B2 3/2016 Roush
9,718,502 B2 8/2017 Kibler et al.
2005/0161976 A1* 7/2005 Ortega B62D 35/001
296/180.4

(71) Applicant: **Larry Lofton**, Rancho Cucamonga, CA (US)

(Continued)

(72) Inventor: **Larry Lofton**, Rancho Cucamonga, CA (US)

Primary Examiner — Susan E Krakower

Assistant Examiner — Jerry Shiuhan-Hua Hsu

(74) *Attorney, Agent, or Firm* — Kenneth Avila

(**) Term: **15 Years**

(57) **CLAIM**

(21) Appl. No.: **29/669,768**

I claim the ornamental design for an undercarriage wind deflector for semitrailers, as shown and described.

(22) Filed: **Nov. 11, 2018**

DESCRIPTION

Related U.S. Application Data

(63) Continuation-in-part of application No. 29/604,519, filed on May 18, 2017, now abandoned.

FIG. 1 is a front, bottom perspective view of the undercarriage wind deflector for semitrailers in a state of use, showing my new design;

(51) **LOC (12) Cl.** **12-16**

FIG. 2 is a front elevation view thereof;

(52) **U.S. Cl.**

FIG. 3 is a right side elevation view thereof;

USPC **D12/181**

FIG. 4 is a rear elevation view thereof;

(58) **Field of Classification Search**

USPC D12/181, 191, 196, 400, 190, 88

FIG. 5 is a left side elevation view thereof;

CPC B62D 35/001; B62D 35/02; B62D 35/005;

FIG. 6 is a top plan view thereof;

B62D 21/20; B60R 19/24; B60R 19/44;

FIG. 7 is a bottom plan view thereof;

B60R 19/48; B60R 19/56

FIG. 8 is a bottom, front perspective view thereof;

See application file for complete search history.

FIG. 9 is a bottom, front, right perspective view thereof

(56) **References Cited**

U.S. PATENT DOCUMENTS

D277,840 S	3/1985	Jacques	
7,780,224 B2	8/2010	Roush	
8,251,436 B2	8/2012	Henderson et al.	
8,276,972 B2	10/2012	Domo et al.	
8,322,778 B1	12/2012	Pfaff	
D683,678 S	6/2013	Willard	
D705,133 S	5/2014	Pfaff	
9,045,176 B1	6/2015	Henderson, II	
9,139,240 B1	9/2015	Long	
9,283,998 B2*	3/2016	Kibler B62D 21/20

FIG. 10 is a bottom, right perspective view thereof

FIG. 11 is a bottom, rear, right perspective view thereof;

FIG. 12 is a bottom, rear, left perspective view thereof;

FIG. 13 is a bottom, left perspective view thereof;

FIG. 14 is a bottom, front, left perspective view thereof;

FIG. 15 is a top, front, right perspective view thereof; and,

FIG. 16 is a top, front, left perspective view thereof.

The broken lines in FIG. 1 showing wheels and part of a truck, illustrate environmental structure that forms no part of the claimed design. The broken lines showing top, rear, and bottom areas of the wind deflector, illustrate portions of the undercarriage wind deflector for semitrailers that form no part of the claimed design.

1 Claim, 16 Drawing Sheets

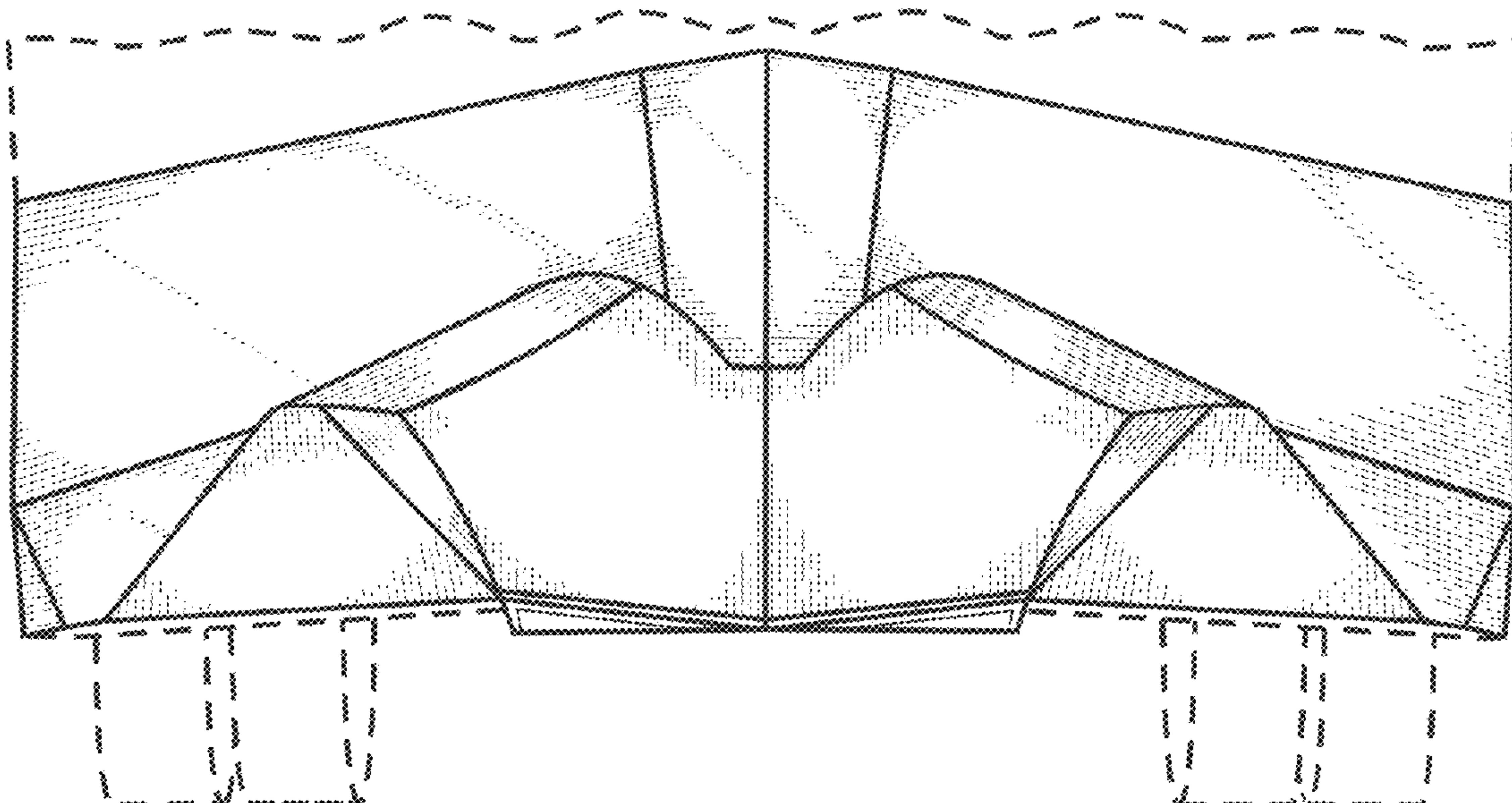

(56)

References Cited

U.S. PATENT DOCUMENTS

2006/0252361	A1 *	11/2006	Henderson, II	B62D 35/001 454/118
2008/0238139	A1 *	10/2008	Cardolle	B62D 35/001 296/180.4
2008/0303311	A1 *	12/2008	Roush	B62D 35/001 296/180.4
2009/0146453	A1 *	6/2009	Ortega	B62D 35/02 296/180.4
2010/0066123	A1 *	3/2010	Ortega	B62D 35/001 296/180.4
2011/0068605	A1 *	3/2011	Domo	B62D 35/001 296/180.4
2013/0249241	A1 *	9/2013	Baker	B62D 35/001 296/180.4
2013/0285411	A1 *	10/2013	Layfield	B62D 35/02 296/180.4
2015/0239513	A1 *	8/2015	Lofton	B62D 35/001 296/180.4

* cited by examiner

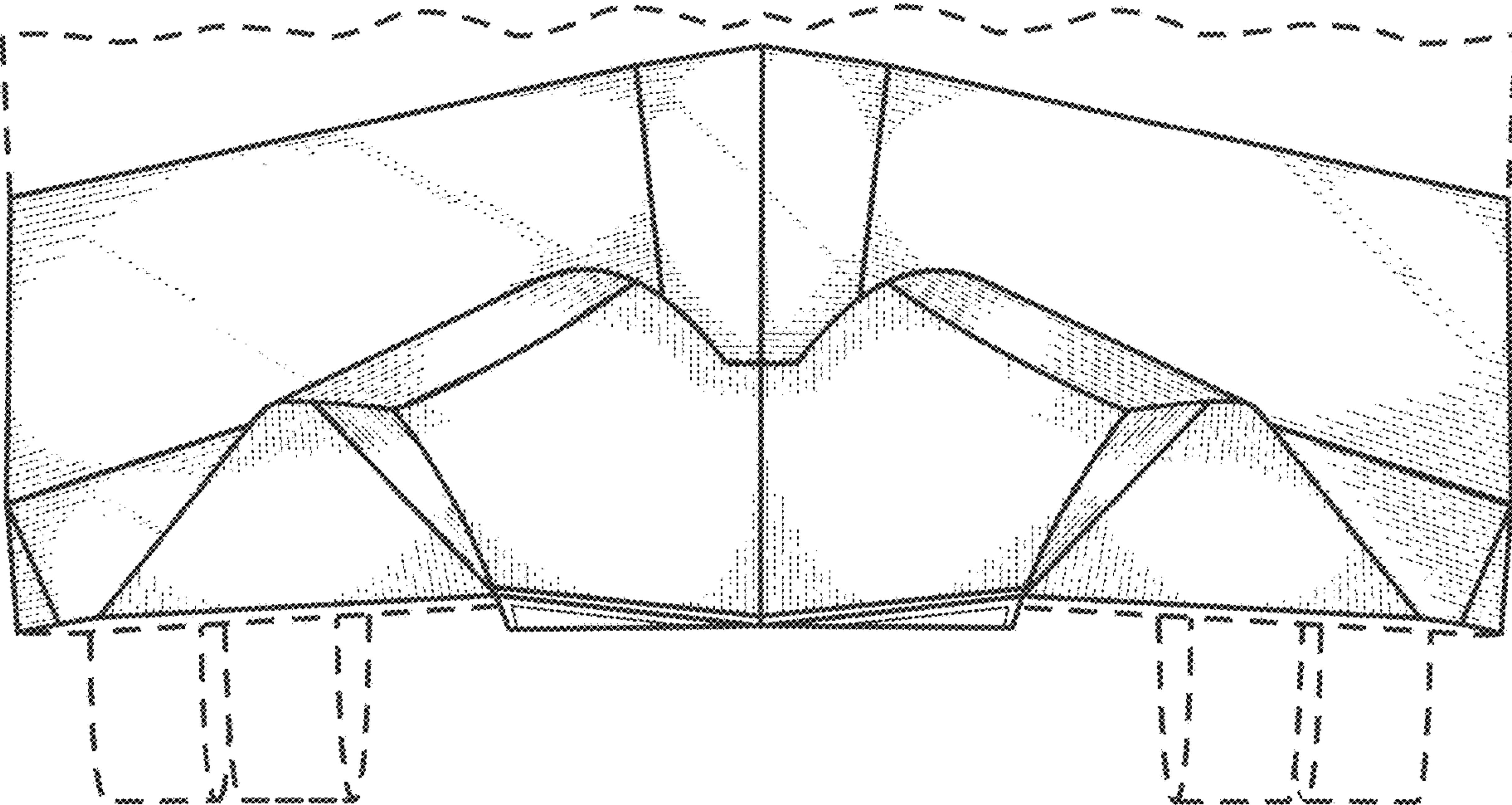

FIG. 1

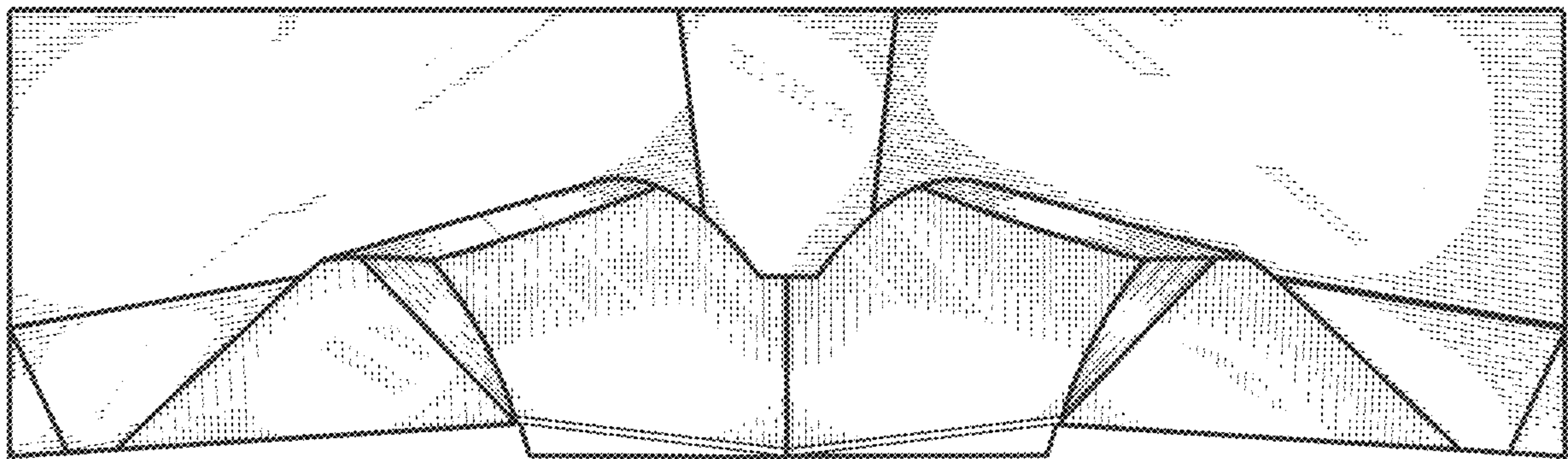

FIG. 2

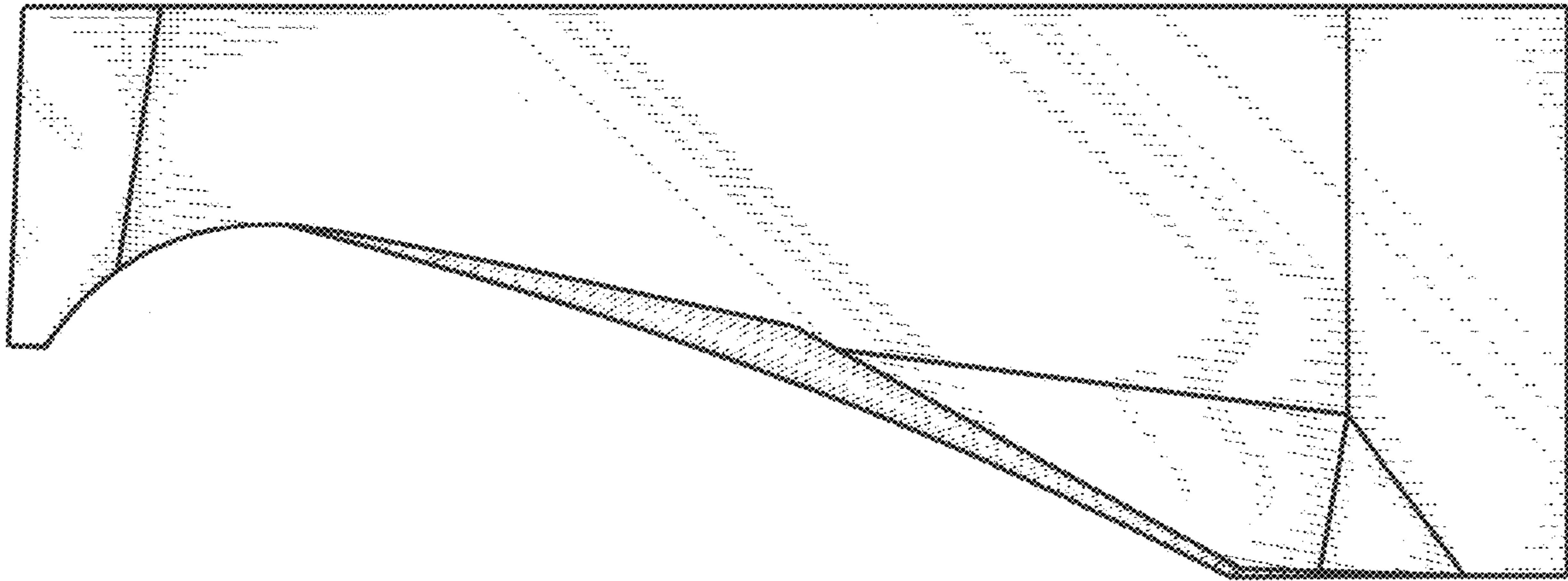

FIG. 3

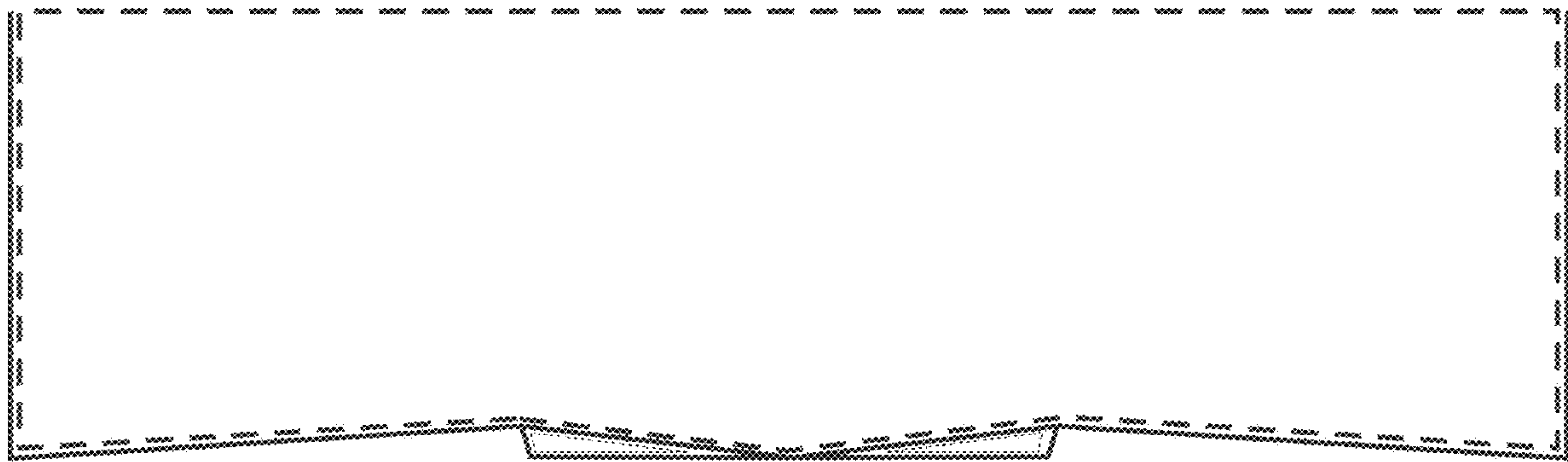

FIG. 4

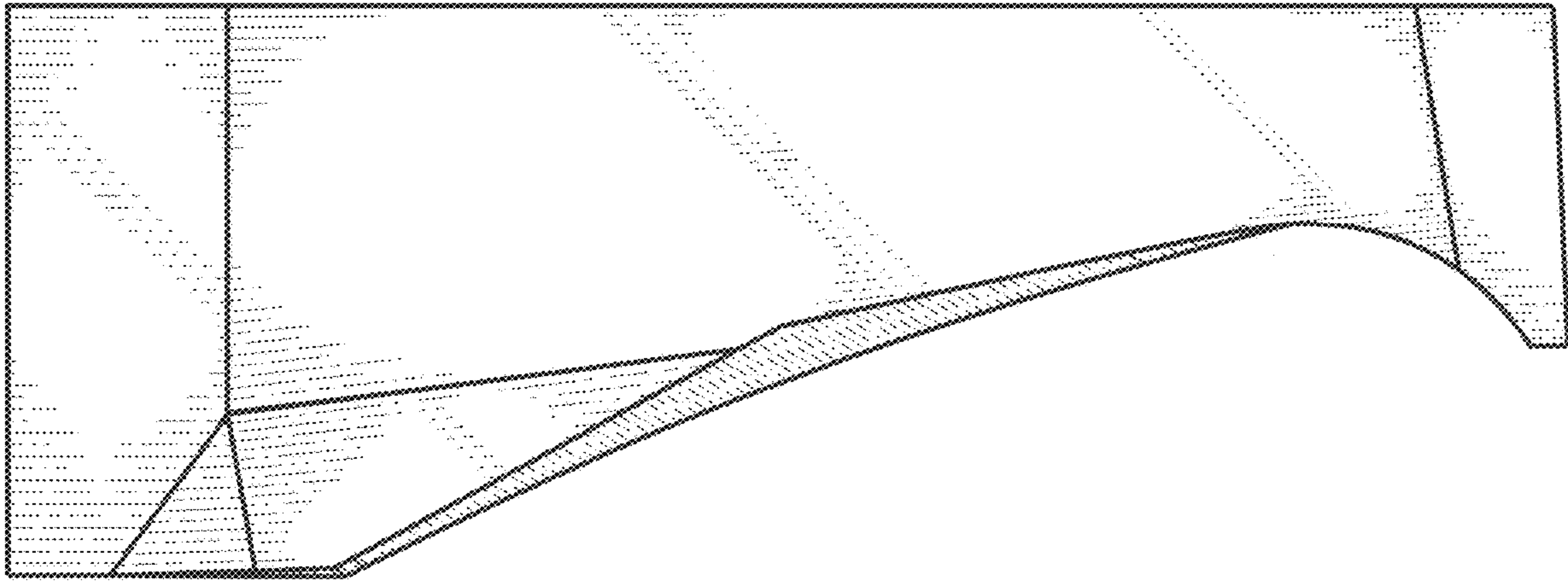

FIG. 5

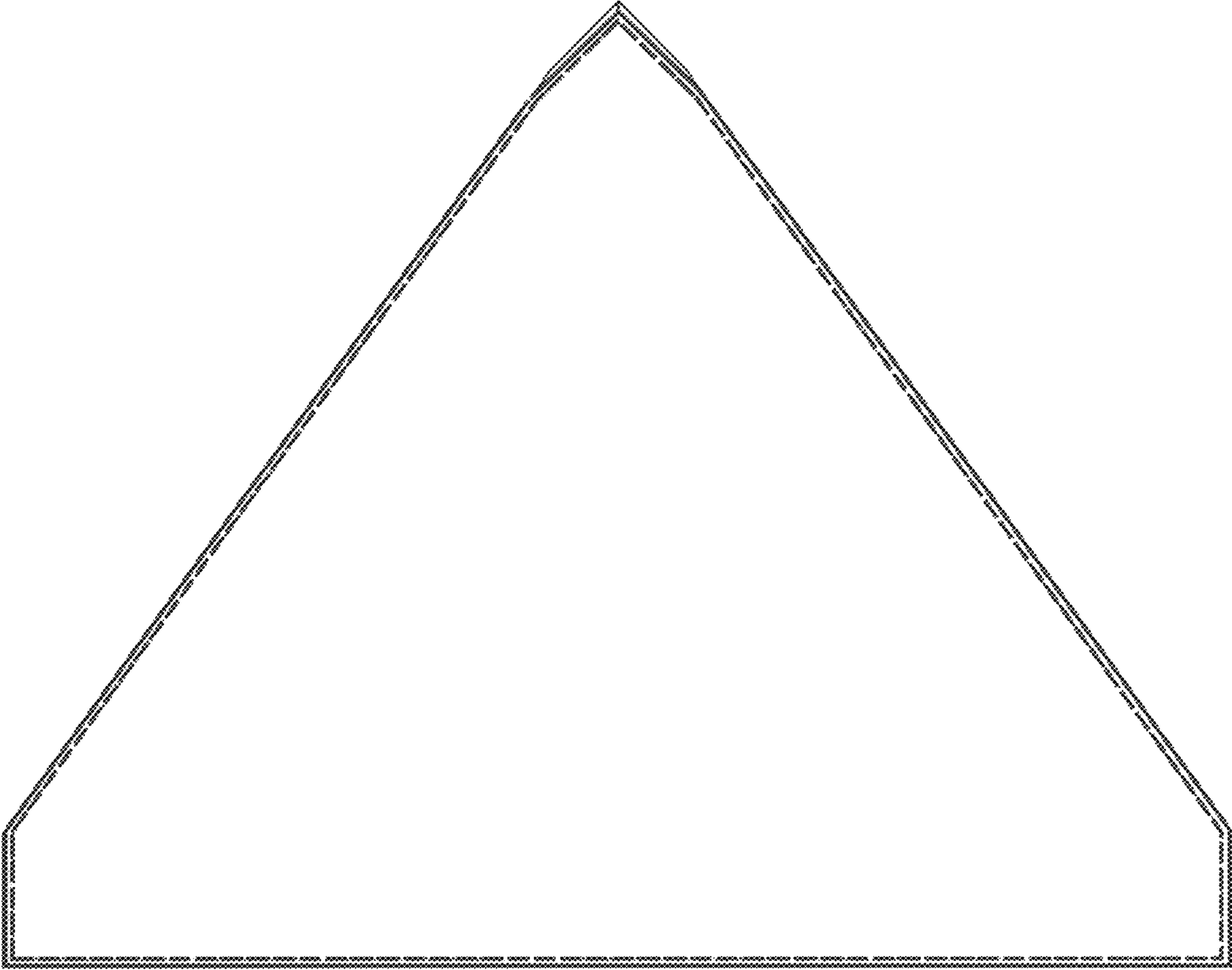

FIG. 6

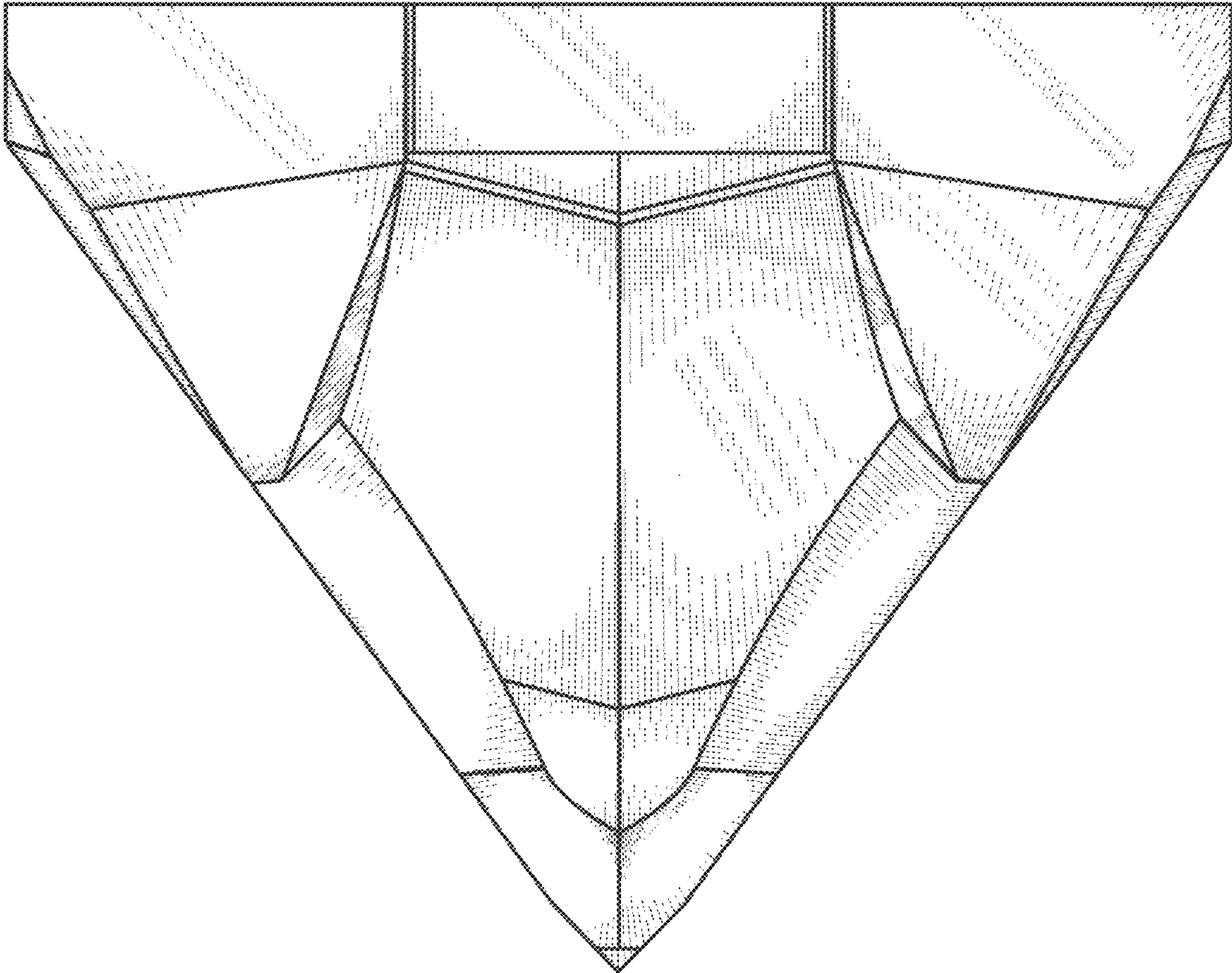

FIG. 7

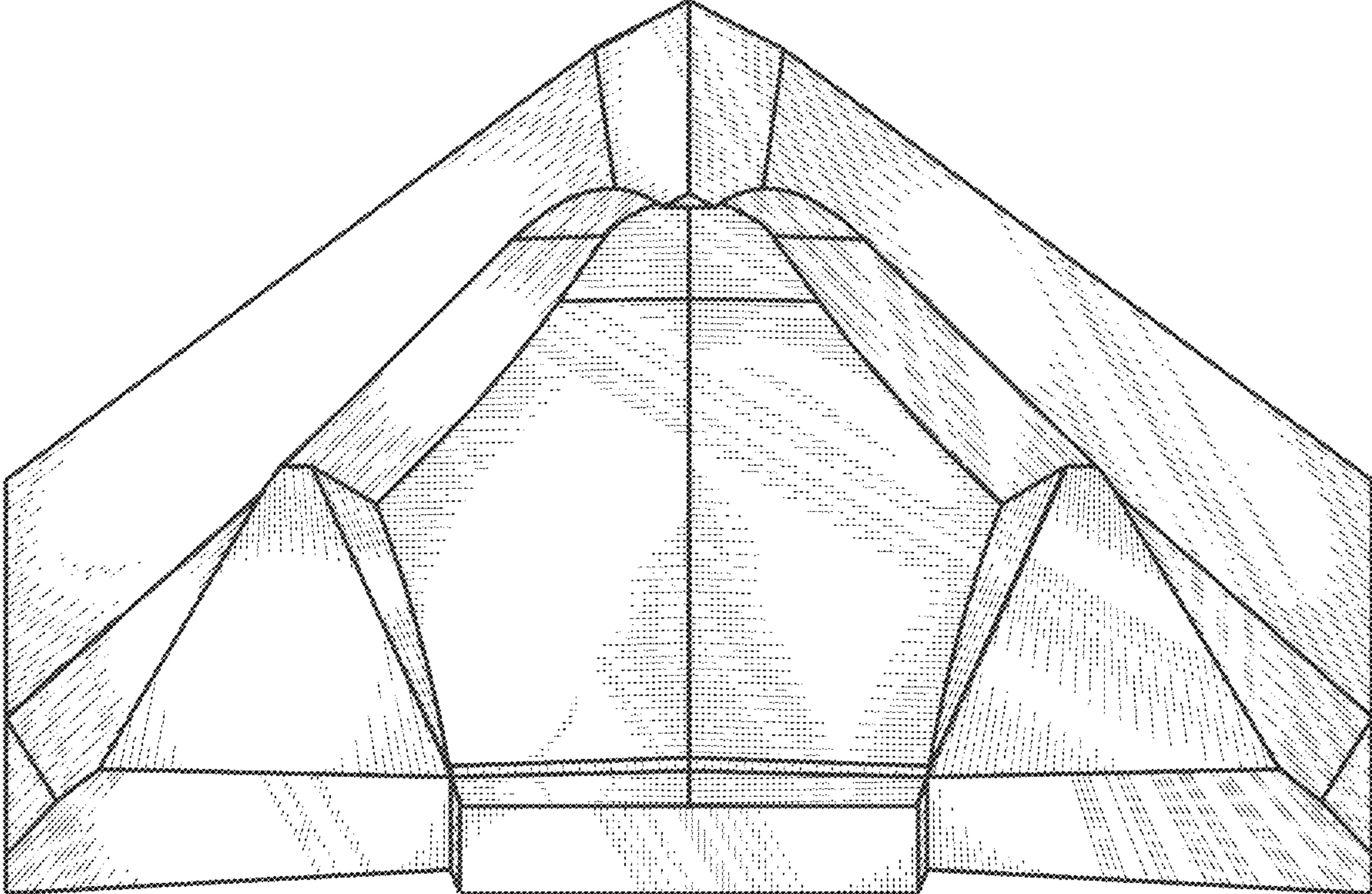

FIG. 8

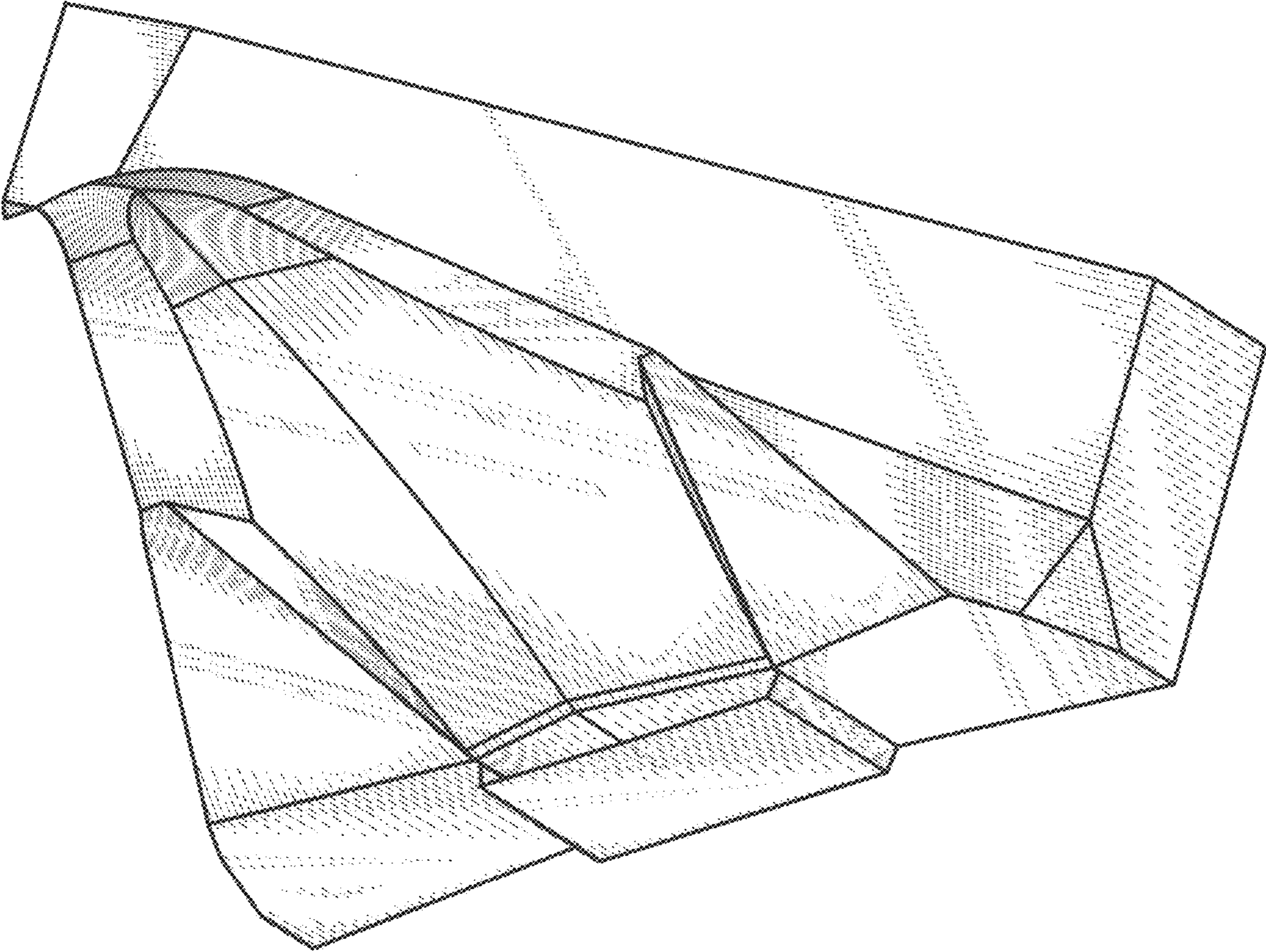

FIG. 9

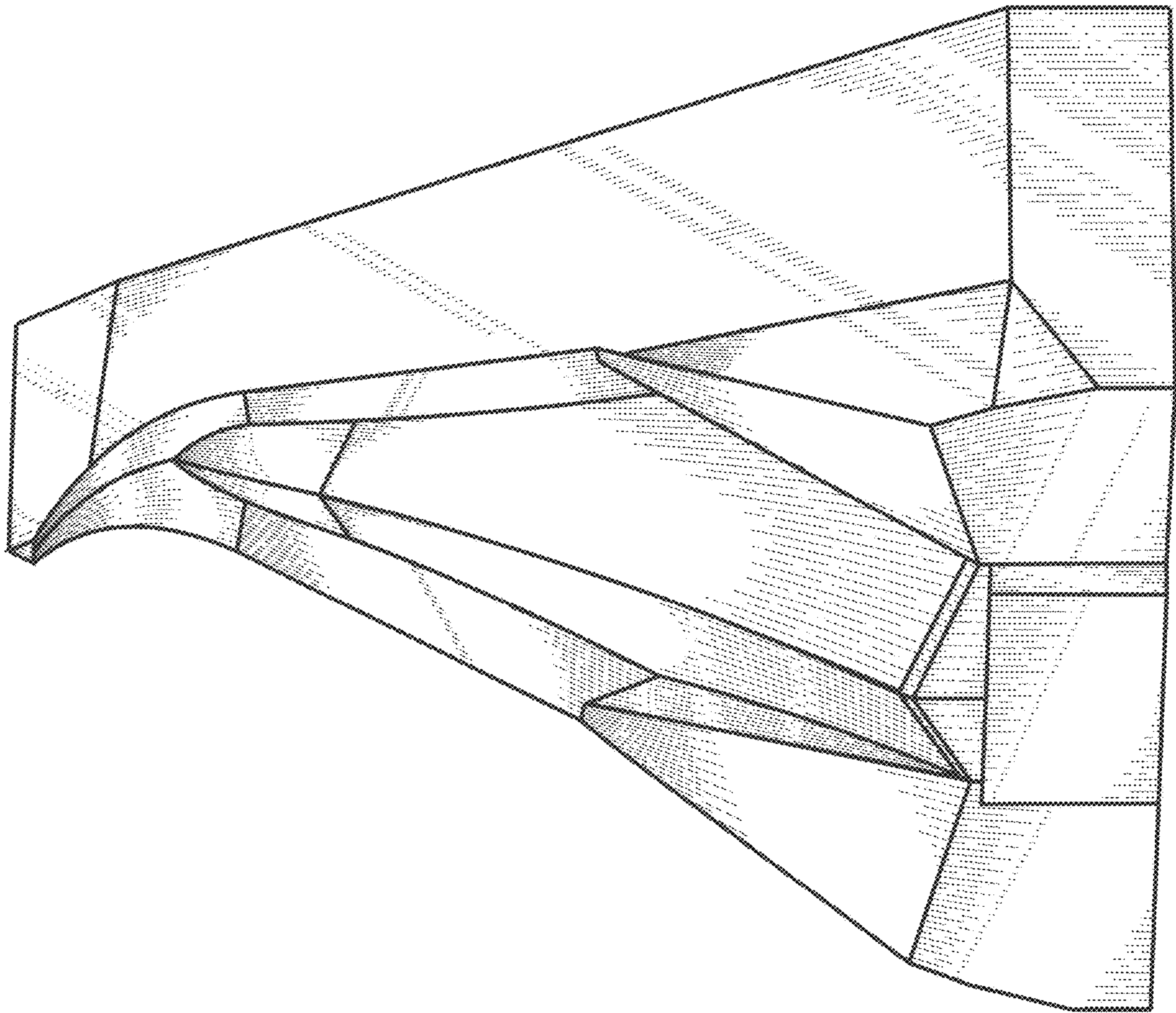

FIG. 10

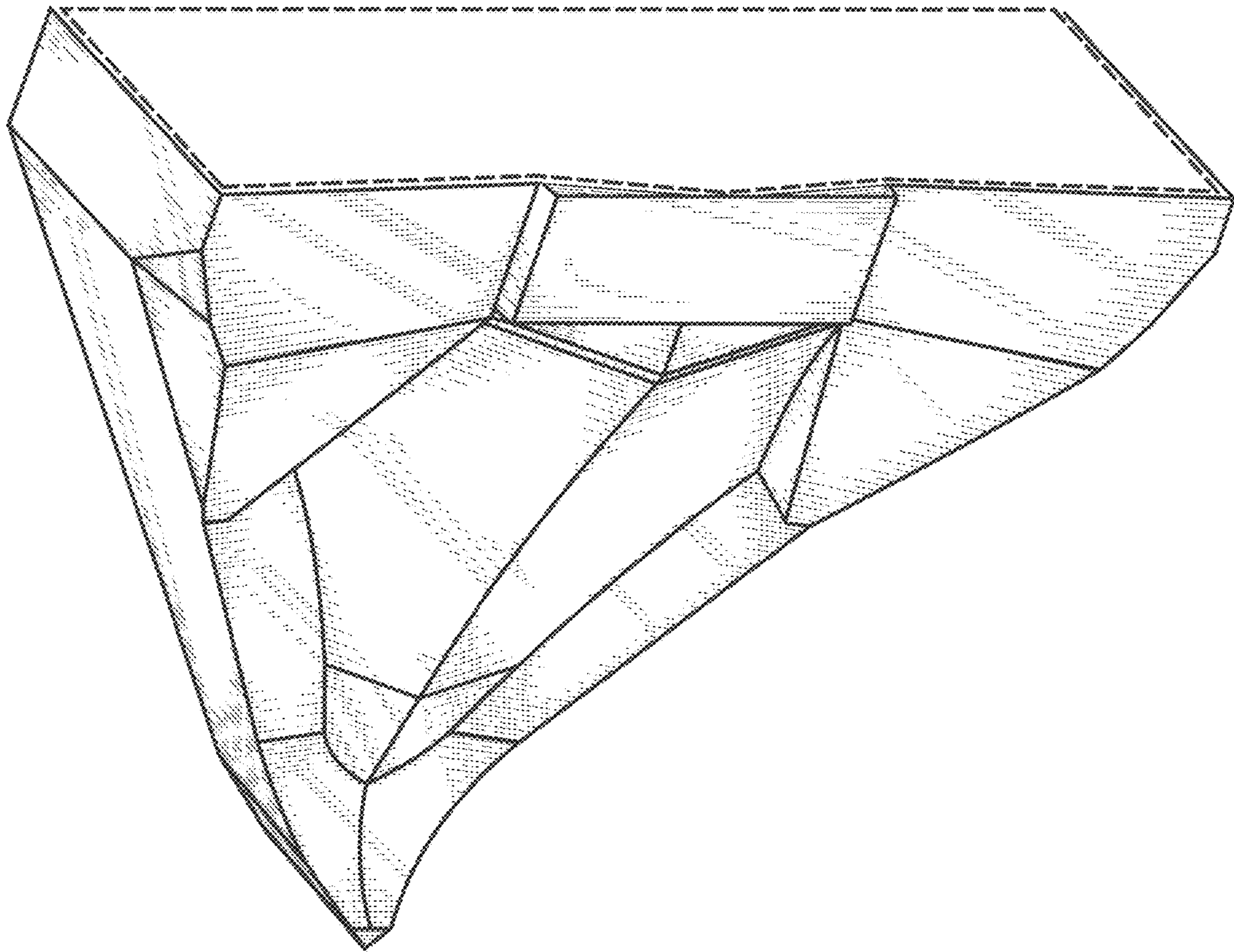

FIG. 11

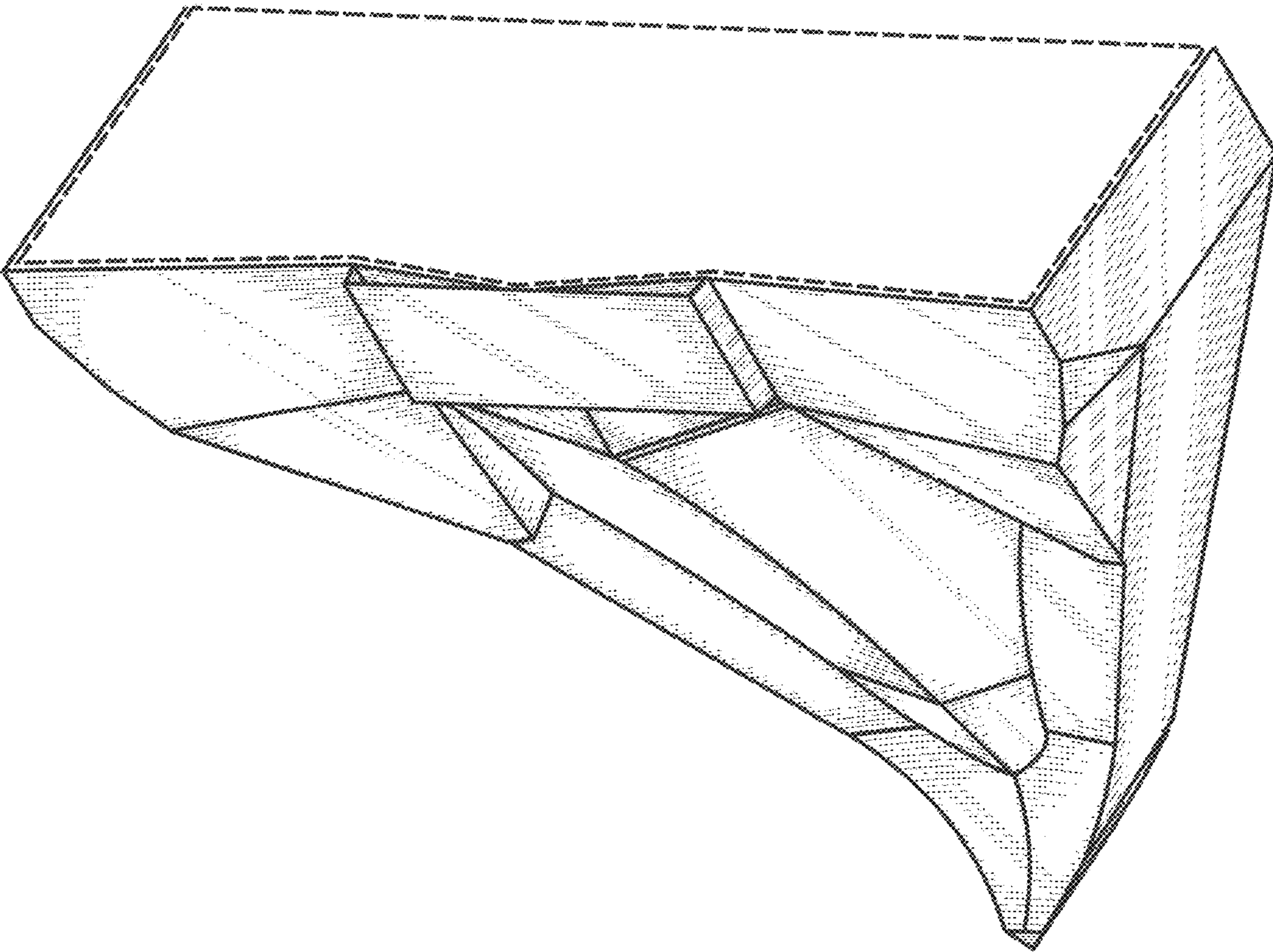

FIG. 12

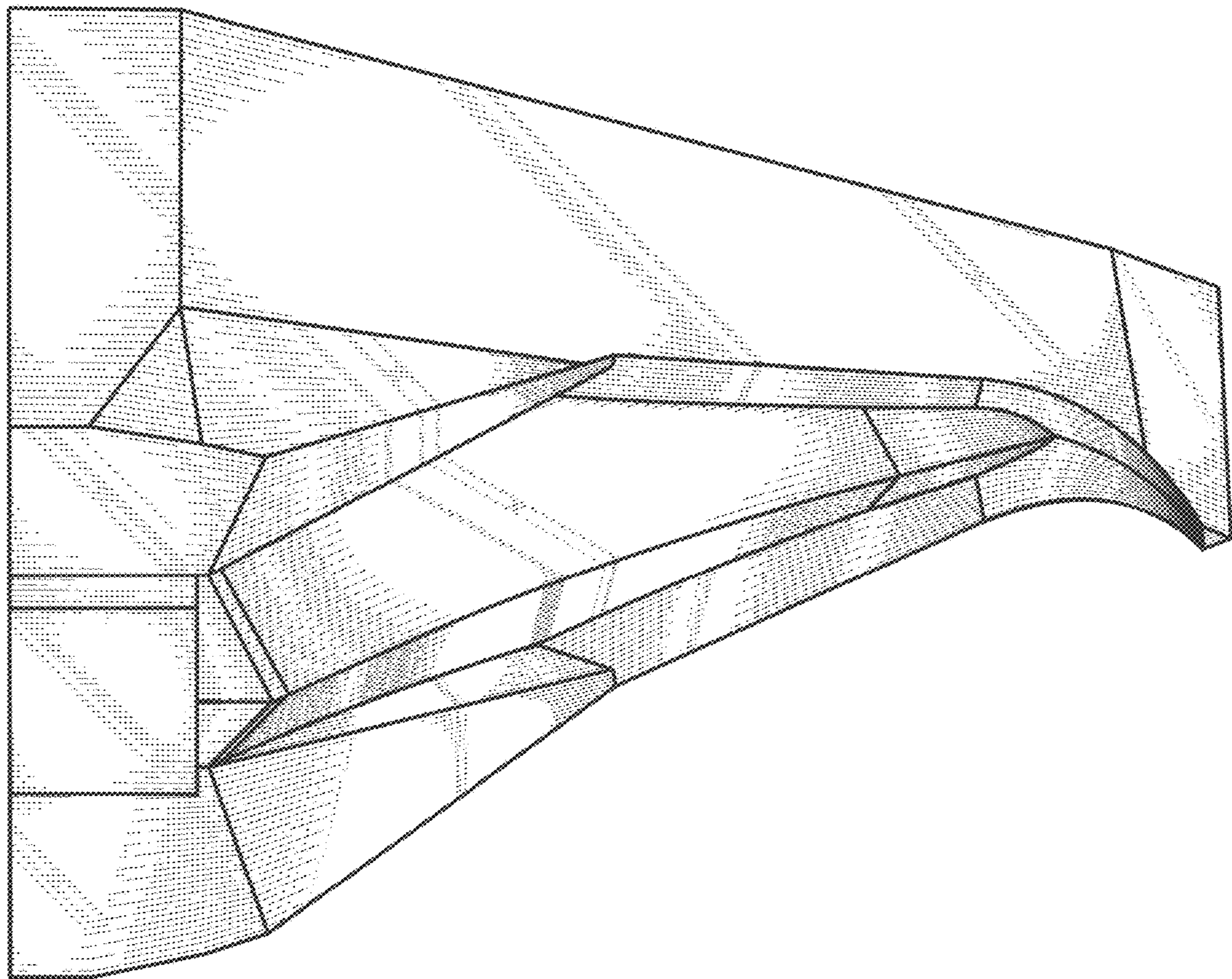

FIG. 13

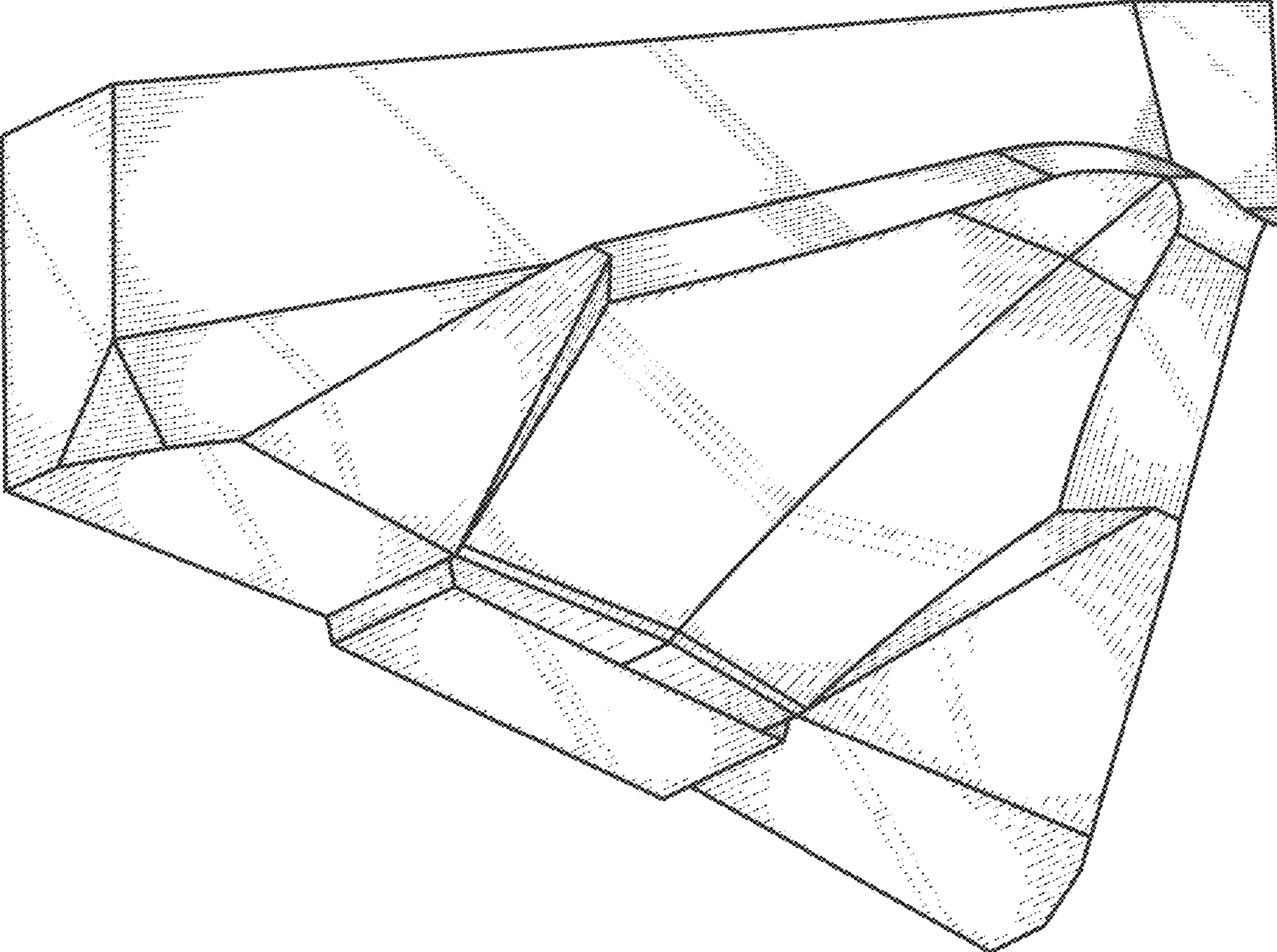

FIG. 14

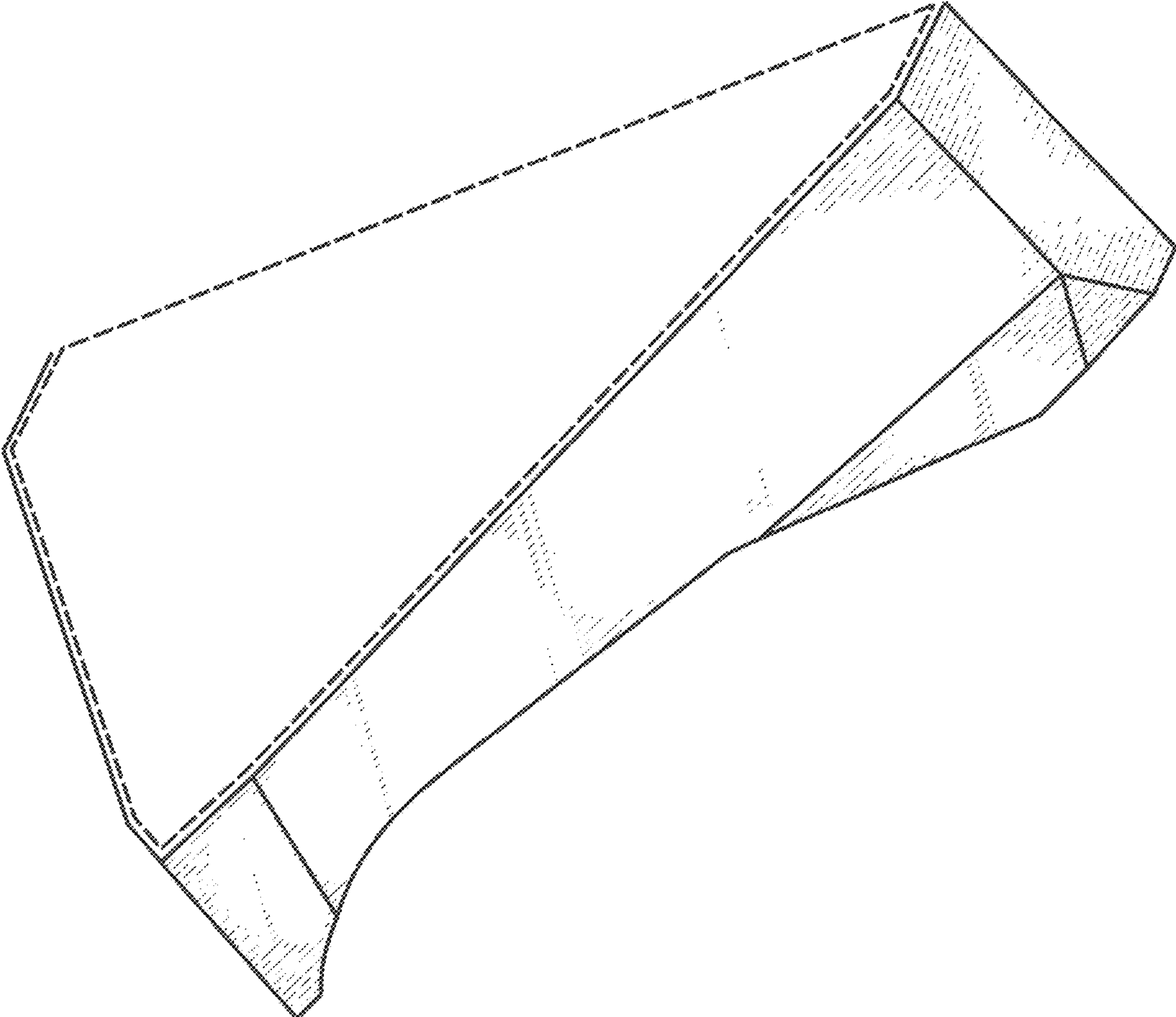

FIG. 15

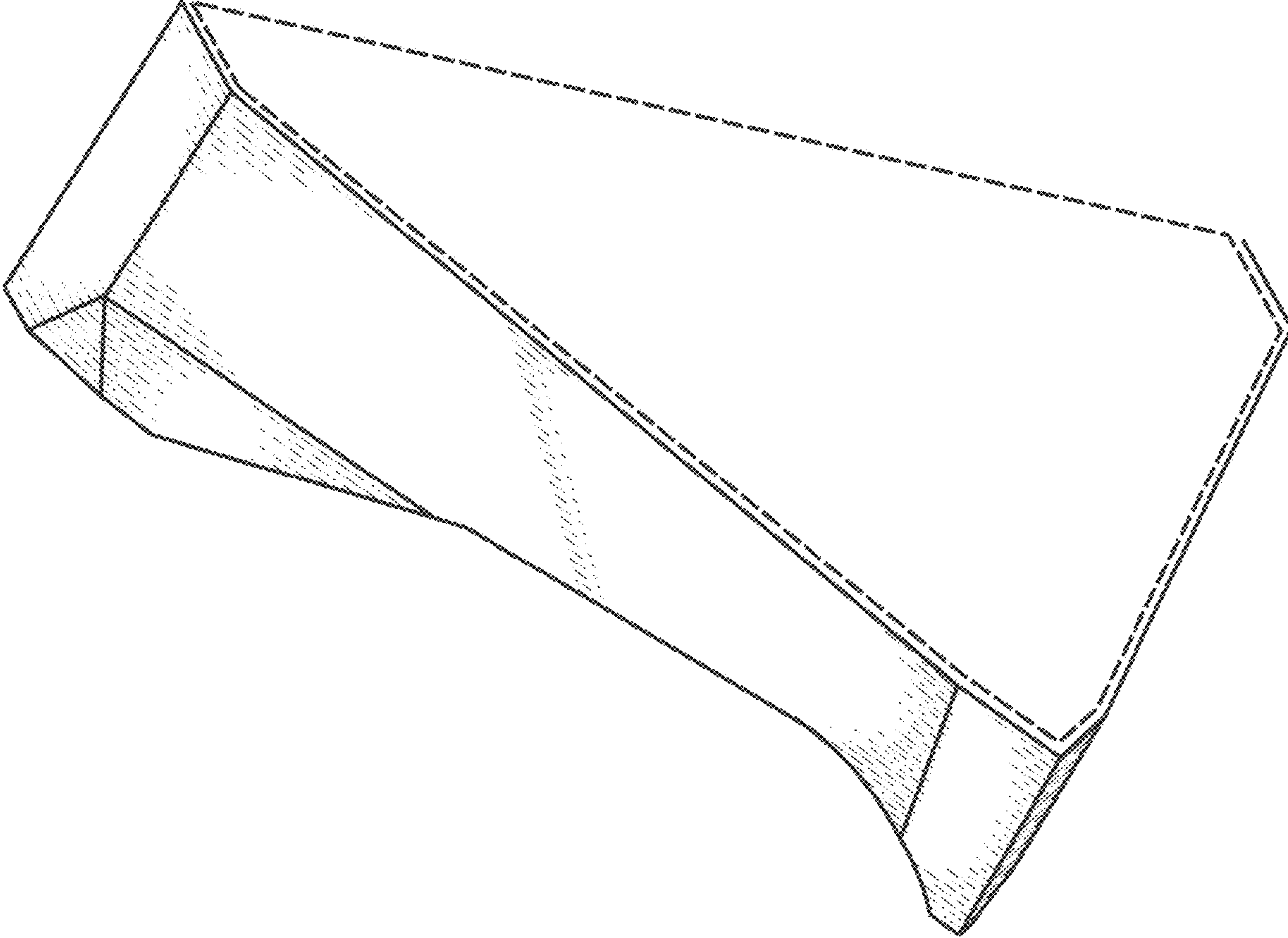

FIG. 16