

US00D900606S

(12) **United States Design Patent** (10) **Patent No.:** **US D900,606 S**
Tse et al. (45) **Date of Patent:** **** *Nov. 3, 2020**

(54) **CLOSURE**

(71) Applicant: **Berlin Packaging, LLC**, Chicago, IL (US)
 (72) Inventors: **Kieron Tse**, Mt. Prospect, IL (US);
Brett Niggel, Chicago, IL (US);
Sharwari Puskala, Chicago, IL (US);
Andrew Sanguinet, La Grange Park, IL (US)

(73) Assignee: **Berlin Packaging, LLC**, Chicago, IL (US)

(*) Notice: This patent is subject to a terminal disclaimer.

(**) Term: **15 Years**

(21) Appl. No.: **29/638,950**

(22) Filed: **Mar. 2, 2018**

(51) **LOC (12) Cl.** **09-07**

(52) **U.S. Cl.**
 USPC **D9/449**

(58) **Field of Classification Search**
 USPC D9/414, 434-436, 438-440, 443-457,
 D9/499, 503-505, 682, 685, 686;
 D7/387, 391, 392, 392.1, 396.2-396.4,
 D7/401.1, 507, 509-511, 538, 900;
 D3/202, 203.2, 318; D28/91.1
 CPC .. A61J 1/00; A61J 1/1412; B65D 1/00; B65D
 1/02; B65D 1/10; B65D 1/46; B65D
 5/46; B65D 41/00; B65D 41/38; B65D
 41/56; B65D 41/62; B65D 47/00; B65D
 47/06; B65D 47/08; B65D 2251/00;
 B65D 2543/00046; B65D 2543/00092;
 B65D 2543/00296; B65D 2585/56; B65D
 2585/545

See application file for complete search history.

(56)

References Cited

U.S. PATENT DOCUMENTS

2,167,574 A	7/1939	Jones	
2,826,343 A	3/1958	Albiani	
2,940,645 A	6/1960	Albiani	
3,018,931 A	1/1962	Westgate	
3,155,285 A	11/1964	Van Baarn	
3,417,897 A	12/1968	Johnson	
3,421,654 A	1/1969	Hexel	
3,836,056 A	9/1974	Pehr	
3,850,350 A	11/1974	Towns et al.	
4,029,202 A	6/1977	Lasich et al.	
D247,848 S	5/1978	Croyle	
4,106,672 A	8/1978	Tecco et al.	
D249,642 S *	9/1978	Ames	D9/447
D249,931 S	10/1978	Russert	
4,262,802 A	4/1981	Lauuwe	
4,284,200 A	8/1981	Bush et al.	
D265,060 S	6/1982	Blank	
4,361,250 A	11/1982	Foster	
4,369,901 A	1/1983	Hidding	
D272,419 S	1/1984	Persch	
D272,807 S	2/1984	Ruhl	
4,433,808 A	2/1984	Gordon et al.	
4,453,666 A	6/1984	Gordon	
D275,181 S	8/1984	Jeffries et al.	
4,463,869 A	8/1984	Lewis	
D275,655 S	9/1984	Bainton	
D276,981 S	1/1985	Cleevely	
D278,312 S	4/1985	Cleevely et al.	
D278,602 S	4/1985	Rosenstein	
4,545,508 A	10/1985	Cribb, Jr.	
4,693,399 A	9/1987	Hickman et al.	
D292,882 S	11/1987	Gross	
4,723,693 A	2/1988	DeCoster	
D295,831 S	5/1988	Urion	
4,759,478 A	7/1988	Richardson et al.	
D305,206 S	12/1989	Hickman et al.	
D306,830 S	3/1990	DeCoster	
4,936,494 A	6/1990	Weidman	
4,955,513 A	9/1990	Bennett	
D313,558 S	1/1991	Gunn et al.	
D314,708 S	2/1991	DeCoster	
D318,015 S	7/1991	DeCoster et al.	
D318,777 S *	8/1991	Freese	D7/392
D318,778 S *	8/1991	Fiore	D7/591
D328,710 S	8/1992	Deflander	

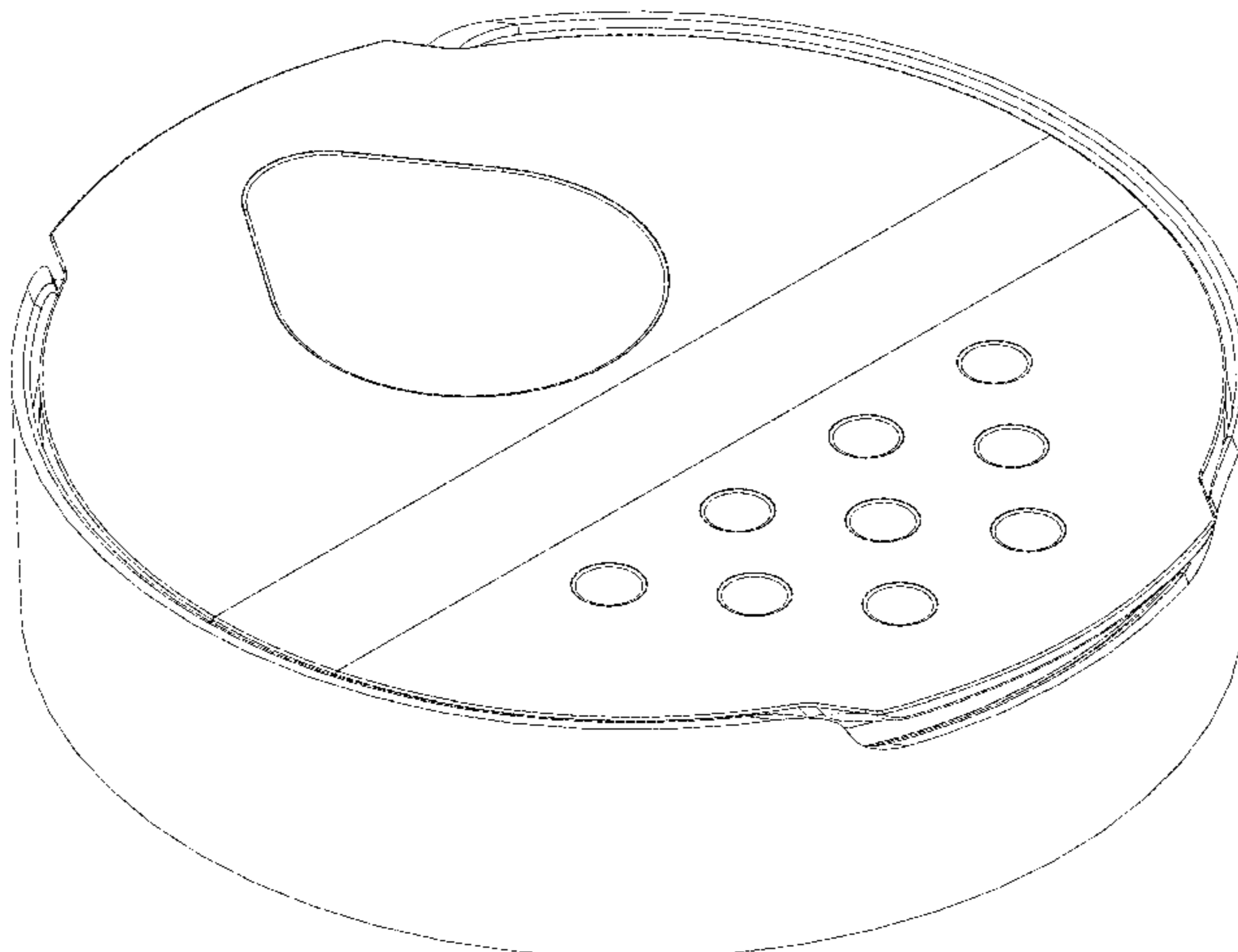

US D900,606 S

5,139,181 A	8/1992	VerWeyst	D513,585 S	1/2006	Biesecker et al.
D331,877 S	12/1992	Robichaud et al.	D516,425 S	3/2006	Haffner et al.
D331,878 S	12/1992	Forsyth	D517,916 S	3/2006	Satt
D334,709 S	4/1993	Fleming et al.	7,007,830 B2	3/2006	Parve et al.
5,211,301 A	5/1993	Groya et al.	D519,029 S	4/2006	Hicks et al.
D336,852 S	6/1993	Pritchard	D519,828 S	5/2006	Cavero et al.
5,219,100 A	6/1993	Beck et al.	D522,362 S	6/2006	Liebe
D339,065 S	9/1993	Forsyth et al.	D522,364 S	6/2006	Hicks et al.
D340,187 S	10/1993	Forsyth	D527,255 S	8/2006	Liebe et al.
D340,188 S	10/1993	Forsyth	D529,800 S	10/2006	Liebe
D344,889 S	3/1994	Kozlowski et al.	D530,610 S	10/2006	Samz et al.
5,330,082 A	7/1994	Forsyth	D531,035 S	10/2006	Pugne
D349,644 S	8/1994	Miyairi et al.	D531,905 S	11/2006	Day
D349,650 S	8/1994	Lonczak et al.	D532,298 S	11/2006	Vogel
D352,899 S	11/1994	Molo	D532,691 S	11/2006	Vogel
D355,121 S	2/1995	Kohl	D533,452 S	12/2006	Vogel
D356,499 S	3/1995	Cauterrels et al.	D533,781 S	12/2006	Freisem et al.
D363,671 S	10/1995	Mueller	D534,067 S	12/2006	Tanner
D364,344 S	11/1995	Shaw	D535,564 S	1/2007	Toth et al.
5,531,347 A	7/1996	Goulding	D536,613 S	2/2007	Vogel et al.
D386,685 S	1/1997	Miller	D536,974 S	2/2007	Smith et al.
5,601,213 A	2/1997	Daniello	D536,975 S	2/2007	Smith et al.
D382,802 S	8/1997	Lambrecht	D537,341 S	2/2007	Liebe et al.
D383,062 S	9/1997	Gilels et al.	D537,724 S	3/2007	Toth et al.
D385,493 S	10/1997	Zhang	D538,160 S	3/2007	Liebe et al.
D385,791 S	11/1997	Forsyth et al.	D538,652 S	3/2007	De Groot et al.
D397,035 S	8/1998	Young et al.	D538,653 S	3/2007	Robinson
D397,247 S	8/1998	Gardner et al.	D539,647 S	4/2007	Solowiejko
D398,241 S	9/1998	Kerbs	D540,678 S	4/2007	Brozell
5,799,838 A	9/1998	Miller	D540,679 S	4/2007	Tanner
D403,241 S	12/1998	Nask et al.	D541,152 S	4/2007	Samz et al.
D403,304 S	12/1998	Awbrey et al.	D541,161 S	4/2007	Ames
D405,011 S	2/1999	DeCoster et al.	D541,426 S	4/2007	Sato et al.
D407,646 S	4/1999	Mogard	D542,132 S	5/2007	Pugne
D410,388 S	6/1999	Fisher et al.	D542,664 S	5/2007	Mayers
D412,279 S	7/1999	Brice	D543,851 S	6/2007	Francic
D414,698 S	10/1999	Mogard et al.	D545,186 S	6/2007	Liebe et al.
5,975,368 A	11/1999	Wood	D547,184 S	7/2007	Kim et al.
D419,879 S	2/2000	Robbins, III	D549,573 S	8/2007	Liebe et al.
D426,772 S	6/2000	Kahl	D550,557 S *	9/2007	Vogel D9/435
D434,657 S	12/2000	Goettner et al.	D554,986 S	11/2007	Galesi
D434,659 S	12/2000	Lonczak et al.	D557,600 S	12/2007	Pettigrew et al.
D436,040 S	1/2001	Warner et al.	D557,979 S	12/2007	Charriez et al.
D442,086 S	5/2001	Mozes	D565,407 S	4/2008	Kick
6,250,517 B1	6/2001	Samz et al.	D567,582 S	4/2008	Blum et al.
D446,722 S	8/2001	Morrow	D568,736 S	5/2008	Born et al.
D447,416 S	9/2001	Anderson	D573,474 S	7/2008	Beam et al.
D448,668 S	10/2001	Baerenwald et al.	D573,889 S	7/2008	Short et al.
D449,782 S	10/2001	Diaz	D576,032 S	9/2008	Wolff et al.
D450,586 S	10/2001	Kick	D576,875 S	9/2008	Steiger et al.
6,308,870 B2	10/2001	Samz et al.	D576,877 S	9/2008	Alcamo et al.
D451,022 S	11/2001	Lueders	D577,595 S	9/2008	Lee
RE37,634 E	4/2002	Hickman et al.	D579,328 S	10/2008	Ribadeneira Mejia et al.
D456,713 S	5/2002	Bried et al.	D582,271 S *	12/2008	Vogel D9/449
D463,280 S	9/2002	Brozell	D582,273 S	12/2008	Vogel
6,460,718 B1	10/2002	Vogel	D582,274 S	12/2008	Vogel
6,464,113 B1	10/2002	Vogel	D582,772 S	12/2008	Bakic
D467,801 S	12/2002	Baerenwald et al.	D583,234 S	12/2008	Lohrman et al.
D468,639 S	1/2003	Wennerstrom et al.	D589,339 S	3/2009	Short et al.
D471,804 S	3/2003	Staples	D589,796 S	4/2009	McGeough
D473,792 S	4/2003	Diefenbach	D591,153 S	4/2009	Strepkoff
6,575,323 B1	6/2003	Martin et al.	D596,029 S	7/2009	Parve
D476,892 S	7/2003	Martin et al.	D599,032 S	8/2009	Bucholtz et al.
D480,003 S	9/2003	Blades	D601,337 S	10/2009	Hale
D482,286 S	11/2003	Samson et al.	D602,781 S	10/2009	Balkum
D485,759 S	1/2004	Janky et al.	D603,702 S	11/2009	Daggett
D489,003 S	4/2004	Loth et al.	D603,703 S	11/2009	Daggett
D491,065 S	6/2004	Solowiejko et al.	D603,704 S	11/2009	Jost et al.
D492,200 S	6/2004	Solowiejko et al.	D604,159 S	11/2009	Pugne
D494,469 S	8/2004	Solowiejko	D605,510 S	12/2009	Weber
D494,812 S	8/2004	Tremblay	D606,399 S	12/2009	Scuturio
D495,256 S	8/2004	Solowiejko	D608,199 S	1/2010	Gross
D502,871 S	3/2005	Ghini et al.	D608,639 S	1/2010	Jackel et al.
D502,873 S	3/2005	Capece et al.	D609,092 S	2/2010	Laib et al.
D509,426 S	9/2005	Samz et al.	D615,862 S	5/2010	Wilson et al.
D509,732 S	9/2005	Staples	7,712,638 B2	5/2010	Kick
D511,685 S	11/2005	Choi	D616,743 S	6/2010	Beam et al.
D513,452 S	1/2006	Parve	D619,007 S	7/2010	Brozell
D513,584 S	1/2006	Solowiejko	D626,411 S	11/2010	Lohrman

US D900,606 S

D627,642 S	11/2010	Mazurkiewicz et al.	D763,074 S	8/2016	Neitzel	
D628,469 S	12/2010	Taylor et al.	D769,715 S	10/2016	Bois	
D628,887 S	12/2010	Groubert et al.	D771,489 S	11/2016	Azelton et al.	
D628,888 S	12/2010	Groubert et al.	D771,492 S	11/2016	Niggel et al.	
D628,889 S	12/2010	Groubert et al.	D772,708 S	11/2016	Lloyd et al.	
D628,890 S	12/2010	Groubert et al.	D773,930 S	12/2016	Azelton et al.	
D628,891 S	12/2010	Groubert et al.	D809,387 S *	2/2018	Tran	D9/449
D628,892 S	12/2010	Groubert et al.	D809,388 S *	2/2018	Tran	D9/449
D628,893 S	12/2010	Groubert et al.	D828,755 S *	9/2018	Jacobs	D9/449
D629,299 S	12/2010	Mazurkiewicz	D834,413 S *	11/2018	Tran	D9/449
D634,198 S	3/2011	Groubert et al.	D838,593 S *	1/2019	Groglopo Favetto	D9/449
7,913,868 B2	3/2011	Dolan et al.	2001/0035424 A1	11/2001	Combe et al.	
D635,864 S	4/2011	Lee	2002/0070218 A1	6/2002	Mozes	
D636,673 S	4/2011	Lohrman et al.	2002/0148886 A1	10/2002	Miess	
D637,074 S	5/2011	Maki et al.	2002/0166869 A1	11/2002	Janes Autonell	
D637,075 S	5/2011	Maki et al.	2003/0090036 A1	5/2003	Vogel	
D638,293 S	5/2011	Arnell et al.	2003/0111495 A1	6/2003	Parve et al.	
D639,658 S	6/2011	Yacht	2004/0089678 A1	5/2004	Martin	
D640,556 S	6/2011	Bragg et al.	2004/0118846 A1	6/2004	Merolla	
D641,627 S	7/2011	Rosenauer	2004/0173645 A1	9/2004	Vogel et al.	
D644,740 S	9/2011	John et al.	2004/0217136 A1	11/2004	Lu et al.	
D649,658 S	11/2011	Belfance et al.	2004/0226950 A1	11/2004	Samz et al.	
8,066,158 B2	11/2011	Vogel et al.	2005/0023304 A1	2/2005	Vogel et al.	
D650,672 S	12/2011	Krallmann	2006/0043100 A1	3/2006	Johnson et al.	
8,100,303 B2	1/2012	Parve	2006/0090671 A1	5/2006	Ekkert	
D657,671 S *	4/2012	O'Brien	2006/0118607 A1	6/2006	Meert	D9/447
D661,582 S	6/2012	Gatrost et al.	2006/0138179 A1	6/2006	Suffa	
D661,583 S	6/2012	Santarelli et al.	2006/0191933 A1	8/2006	Hicks et al.	
D661,588 S	6/2012	Irani et al.	2006/0237388 A1	10/2006	Kick	
D663,111 S	7/2012	Paslowski	2006/0243759 A1	11/2006	King et al.	
D663,202 S	7/2012	Biesecker et al.	2007/0007310 A1	1/2007	Antal, Sr.	
D664,035 S	7/2012	Hu et al.	2007/0145082 A1 *	6/2007	Parve	B65D 47/0857 222/480
D664,850 S	8/2012	Fracasso				
D666,493 S	9/2012	Cummings et al.	2007/0164027 A1	7/2007	Auer	
D666,494 S	9/2012	Stull et al.	2007/0170192 A1	7/2007	Blum et al.	
8,297,457 B2	10/2012	Kick	2007/0221605 A1	9/2007	Pugne et al.	
D671,001 S	11/2012	Wisniewski et al.	2007/0228079 A1	10/2007	Vogel et al.	
D672,650 S	12/2012	Wisniewski et al.	2007/0278254 A1	12/2007	Wisniewski	
D672,654 S	12/2012	Jackel	2007/0295762 A1 *	12/2007	Zeitlin	A47G 19/24 222/480
D673,040 S	12/2012	Stephan et al.				
D673,044 S	12/2012	Wisniewski	2008/0047976 A1	2/2008	Scheer et al.	
D679,182 S	4/2013	Papiernik	2008/0251573 A1	10/2008	Nobilet et al.	
D679,184 S	4/2013	Fedewa et al.	2008/0257918 A1 *	10/2008	Vogel	B65D 47/0895 222/480
D682,102 S	5/2013	Davis et al.				
D682,608 S *	5/2013	Audette	2008/0264961 A1	10/2008	Sawyer	D7/392
D682,612 S	5/2013	Rzepecki	2008/0277369 A1	11/2008	Robinson	
8,448,798 B2	5/2013	Groubert et al.	2008/0290108 A1	11/2008	Robinson	
D688,554 S	8/2013	Fracasso	2008/0290110 A1	11/2008	Gelardi et al.	
D692,720 S	11/2013	Audette	2009/0008286 A1	1/2009	Croft et al.	
D693,223 S	11/2013	Walter et al.	2009/0159607 A1	6/2009	Kratzer	
D694,575 S	12/2013	Andres et al.	2009/0166361 A1	7/2009	Lourenco	
D702,551 S	4/2014	Wisniewski et al.	2010/0102109 A1	4/2010	Flecker et al.	
D704,057 S	5/2014	Bar-Tal et al.	2010/0127011 A1	5/2010	Britto et al.	
D706,637 S	6/2014	James	2010/0140266 A1	6/2010	Lohrman et al.	
D708,947 S	7/2014	Weber	2010/0140304 A1 *	6/2010	Walunis	B65D 43/161 222/480
D709,765 S	7/2014	Hager				
D711,230 S	8/2014	den Boer	2010/0219186 A1	9/2010	Kuwagaki et al.	
D711,231 S	8/2014	Pun	2010/0224643 A1	9/2010	Daggett	
D713,723 S	9/2014	den Boer	2011/0127269 A1	6/2011	Bucholtz et al.	
D713,724 S	9/2014	den Boer	2011/0239597 A1	10/2011	Wilson et al.	
D720,622 S	1/2015	Gelov	2012/0211493 A1	8/2012	Daggett	
D721,578 S	1/2015	Julies et al.	2012/0241454 A1	9/2012	Dennis	
D722,267 S	2/2015	Miranda De Aruajo et al.	2012/0273452 A1	11/2012	Soehnlén et al.	
D730,182 S	5/2015	Leung et al.	2013/0001184 A1	1/2013	Groubert	
D731,303 S	6/2015	Daggett	2014/0284353 A1	9/2014	Wear et al.	
D731,309 S	6/2015	Lee et al.	2014/0338173 A1	11/2014	Fuller et al.	
D732,958 S	6/2015	Peneda	2015/0034585 A1	2/2015	Giusti	
D735,576 S	8/2015	Aldridge	2015/0069061 A1	3/2015	Daggett	
D738,732 S	9/2015	Gelove	2015/0083724 A1	3/2015	Lagace et al.	
D739,236 S	9/2015	Monbarren et al.	2015/0344196 A1	12/2015	Groubert et al.	
D741,182 S	10/2015	Davis et al.	2015/0367998 A1	12/2015	Daggett et al.	
D744,328 S	12/2015	Ramachandran et al.	2015/0368002 A1	12/2015	Steven et al.	
D747,651 S	1/2016	Hawry et al.	2015/0368008 A1	12/2015	Sugiyama et al.	
D749,943 S	2/2016	Mitten et al.	2015/0368011 A1	12/2015	Groubert	
D756,219 S	5/2016	Sanfilippo et al.	2016/0052681 A1	2/2016	Hendricks et al.	
D760,076 S	6/2016	O'Toole et al.	2016/0101914 A1	4/2016	Logel et al.	
9,371,162 B2	6/2016	Walunis et al.	2016/0185493 A1	6/2016	Cox	
D761,651 S	7/2016	Sanfilippo et al.	2017/0129658 A1 *	5/2017	Moody	B65D 47/0838
D761,652 S	7/2016	Dietvorst et al.				

FOREIGN PATENT DOCUMENTS

CA	2336756	10/2009
CA	2701019	6/2014
CA	2701024	12/2014
DE	7818747	9/1978
DE	4228723	8/1992
DE	29822608	5/1999
DE	20100955	3/2001
DE	2020150081455	1/2016
EP	0697344	9/1998
EP	1160172	9/2004
EP	1971529	5/2007
EP	1727738	2/2008
FR	2238455	2/1975
FR	2725962	12/1996
FR	2967653	11/2012
GB	879851	10/1961
GB	886607	1/1962
GB	1258979	1/1972
JP	2987078	12/1999
JP	2002193298	7/2002
KR	100590357	6/2006
KR	101533639	6/2015
KR	101651929	8/2016
NL	1017572	12/2001
NO	1694329000527	6/1992
WO	199532126	11/1995
WO	199534502	12/1995
WO	200661449	10/2000
WO	200216218	2/2002
WO	2005026013	3/2005
WO	2007106840	9/2007
WO	2007119251	10/2007
WO	2010068548	6/2010
WO	2012160222	11/2012
WO	2013178356	12/2013
WO	2014172419	10/2014
WO	2014185765	11/2014
WO	2015049226	4/2015
WO	2015069257	5/2015
WO	2016014550	1/2016
WO	2016073325	5/2016
WO	2016108590	7/2016
WO	2016186983	11/2016

* cited by examiner

Primary Examiner — Wendy L Arminio
 (74) Attorney, Agent, or Firm — Adam K. Sacharoff;
 Much Shelist, P.C.

(57)

CLAIM

The ornamental design for a closure, as shown and described.

DESCRIPTION

FIG. 1 is a front left side perspective view showing the new design for a closure;
 FIG. 2 is a underside perspective view thereof;
 FIG. 3 is a left side view thereof;
 FIG. 4 is a right side view thereof;
 FIG. 5 is a front elevation view thereof;
 FIG. 6 is a rear elevation view thereof;
 FIG. 7 is a top plan view thereof;
 FIG. 8 is a bottom plan view thereof;
 FIG. 9 is a rear left side perspective view of the closure of FIG. 1 shown with a pour lid feature in the open configuration;
 FIG. 10 is a front left side perspective view thereof;
 FIG. 11 is a underside perspective view thereof;
 FIG. 12 is a left side view thereof;
 FIG. 13 is a right side view thereof;
 FIG. 14 is a rear elevation view thereof;
 FIG. 15 is a front elevation view thereof;
 FIG. 16 is a top plan view thereof;
 FIG. 17 is a bottom plan view thereof;
 FIG. 18 is a front left side perspective view of the closure of FIG. 1 shown with a sift lid feature in the open configuration;
 FIG. 19 is a front right side perspective view thereof;
 FIG. 20 is a rear right side perspective view thereof;
 FIG. 21 is a underside perspective view thereof;
 FIG. 22 is a left side view thereof;
 FIG. 23 is a right side view thereof;
 FIG. 24 is a front elevation view thereof;
 FIG. 25 is a rear elevation view thereof;
 FIG. 26 is a top plan view thereof; and,
 FIG. 27 is a bottom plan view thereof.
 The broken lines depict portions of the closure that form no part of the claimed design.

1 Claim, 27 Drawing Sheets

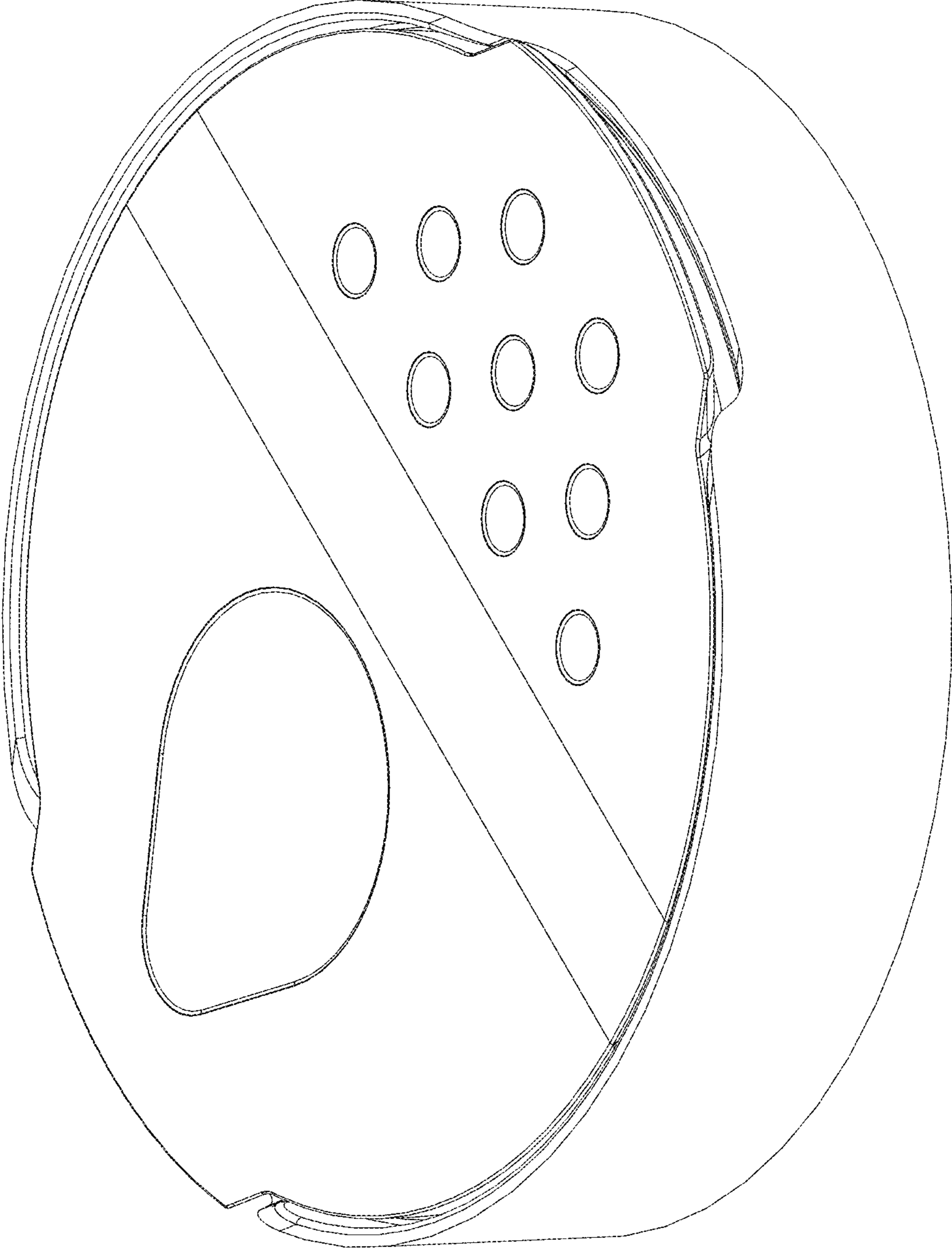

FIG. 1

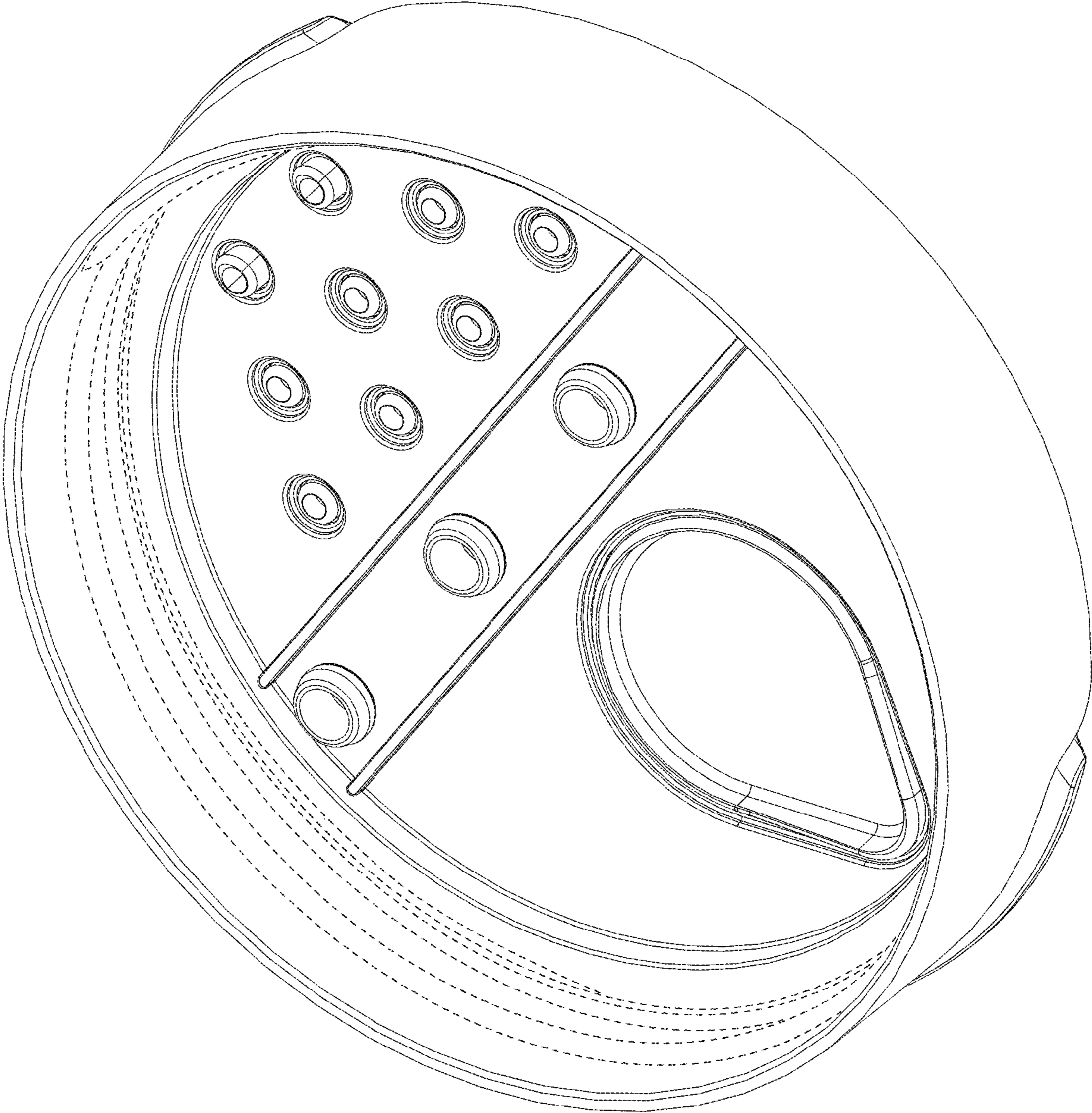

FIG. 2

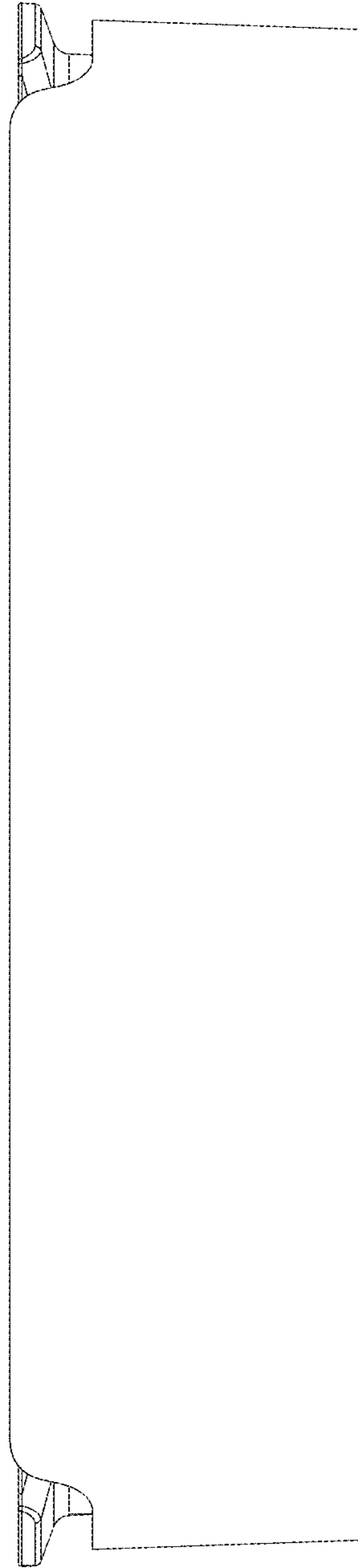

FIG. 3



FIG. 4

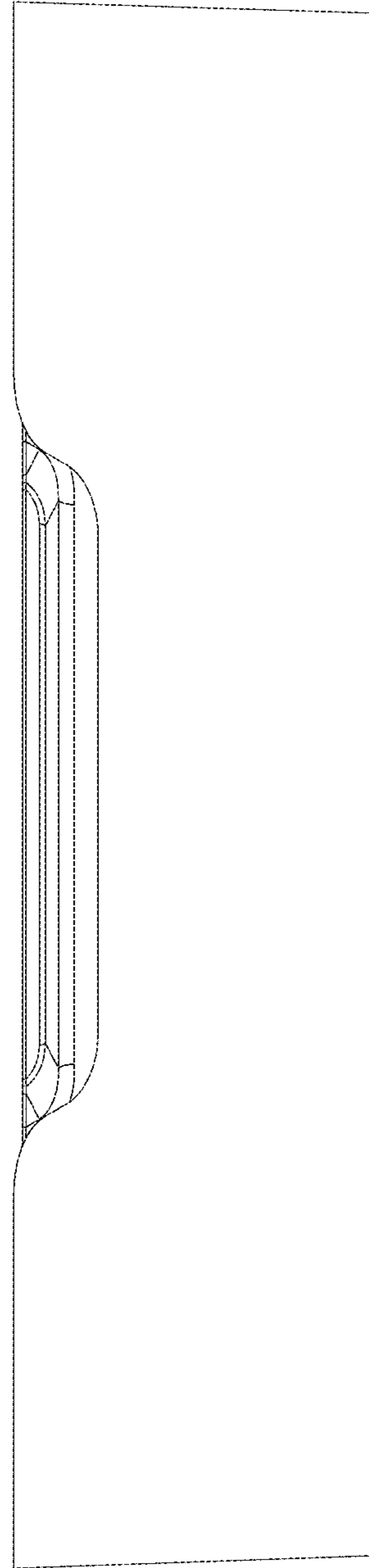

FIG. 5

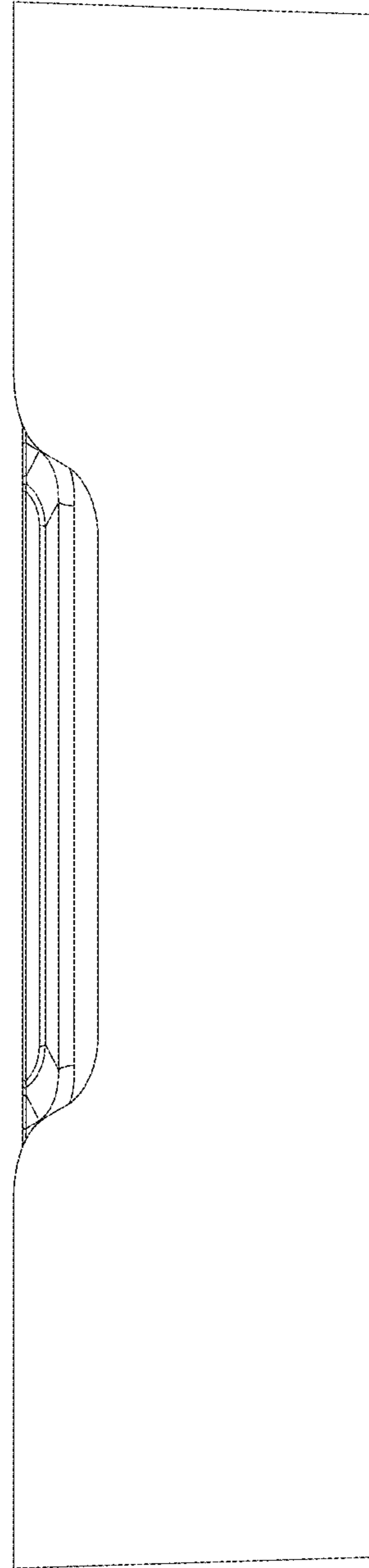

FIG. 6

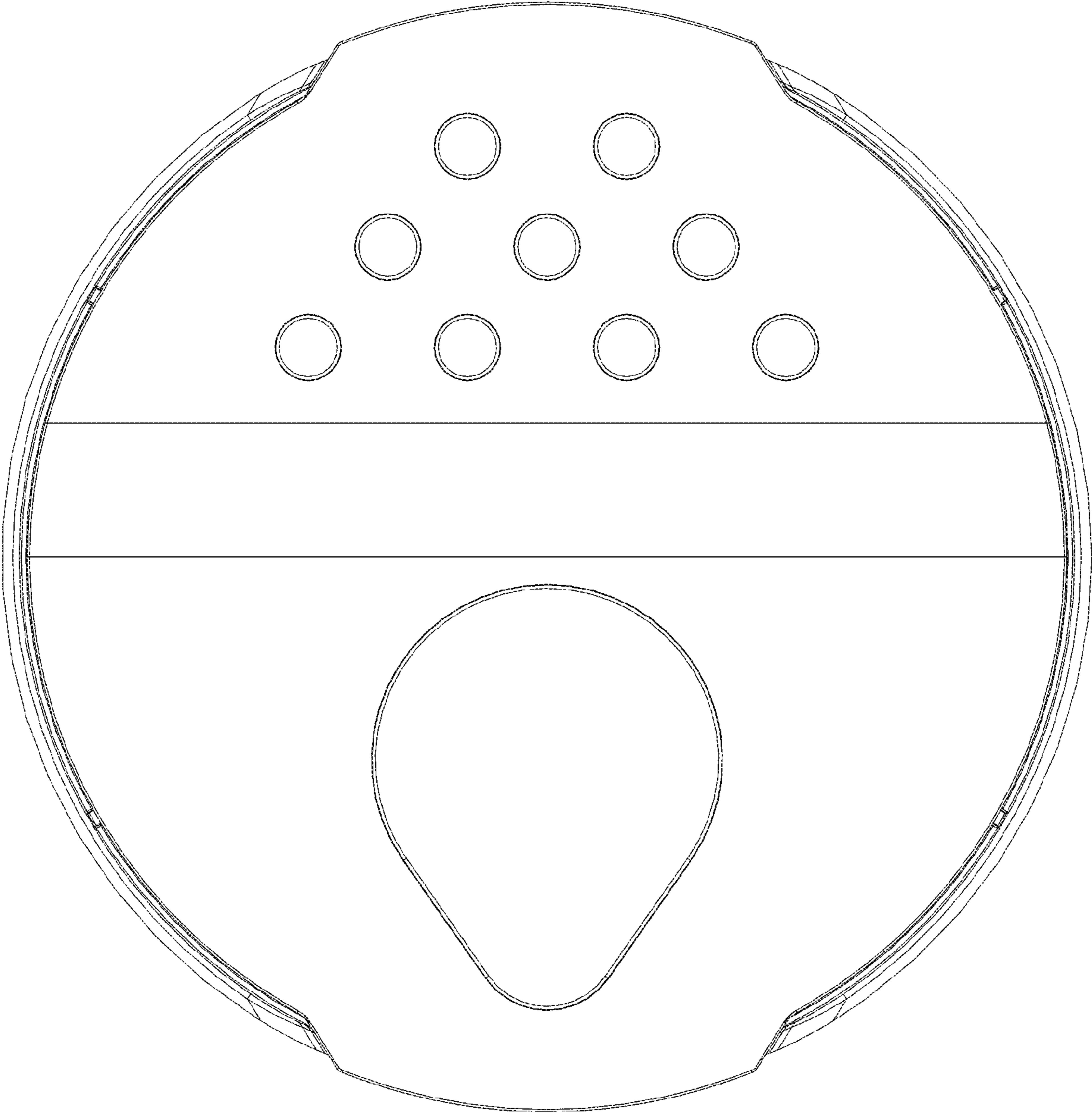

FIG. 7

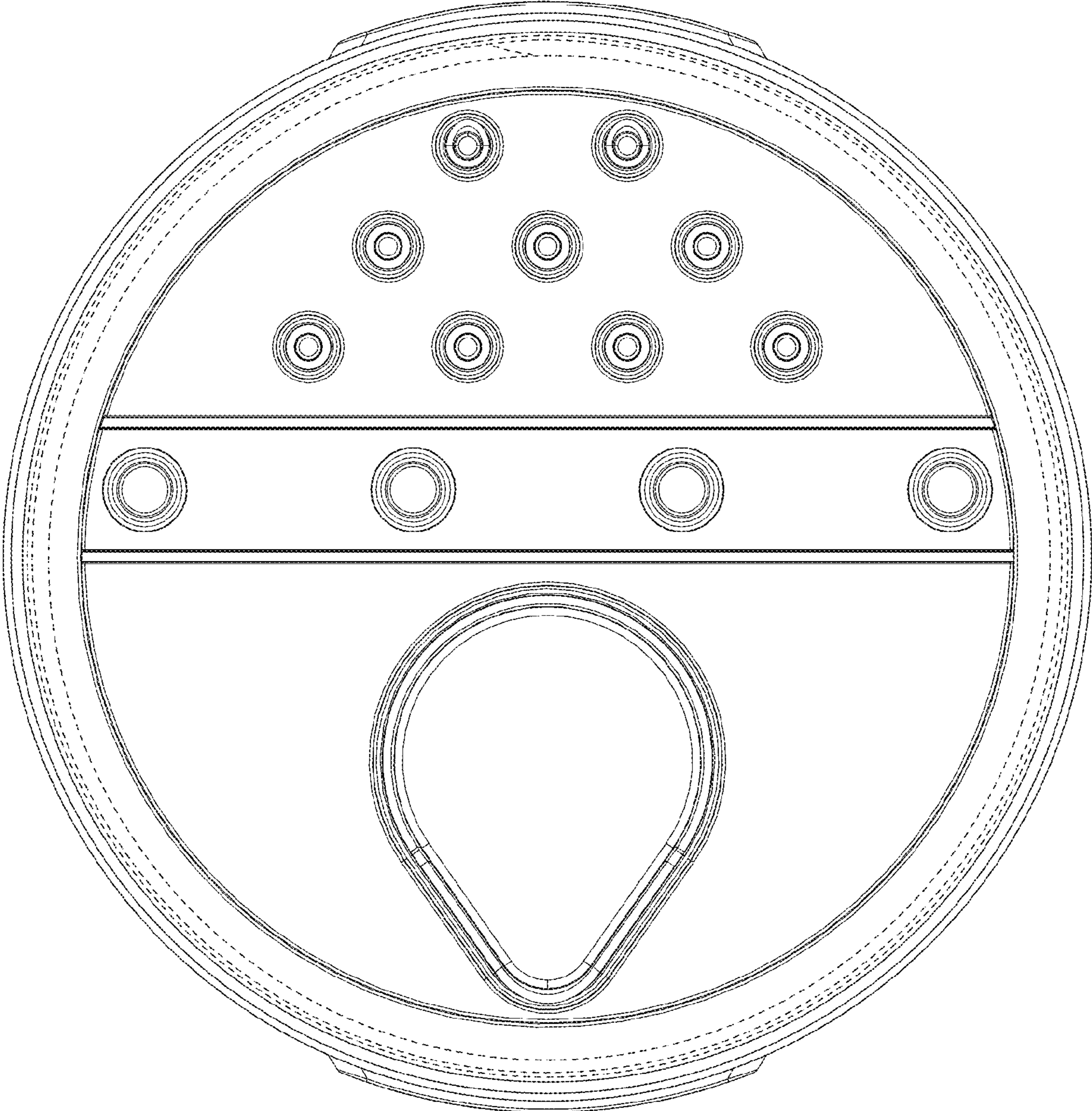

FIG. 8

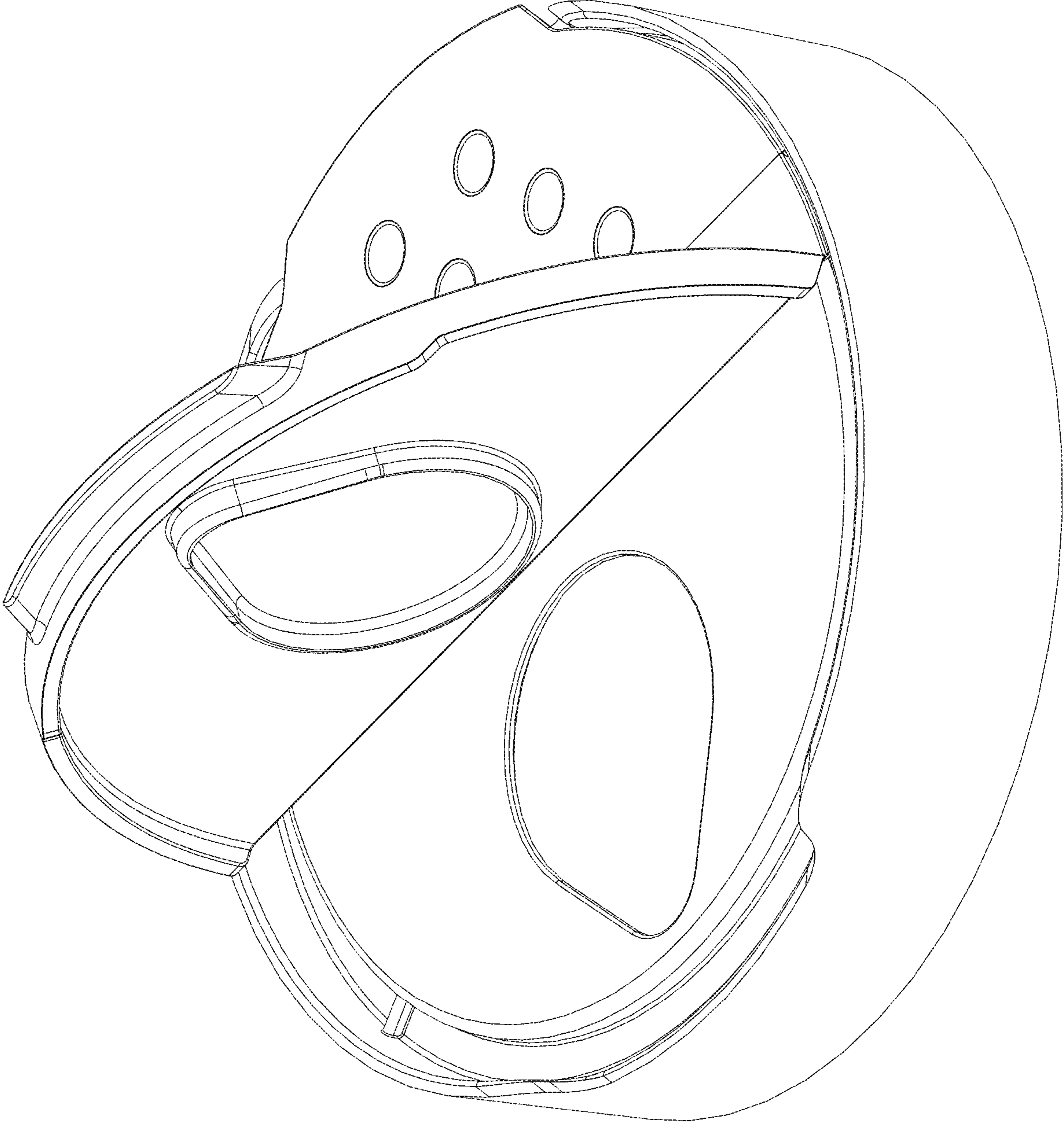

FIG. 9

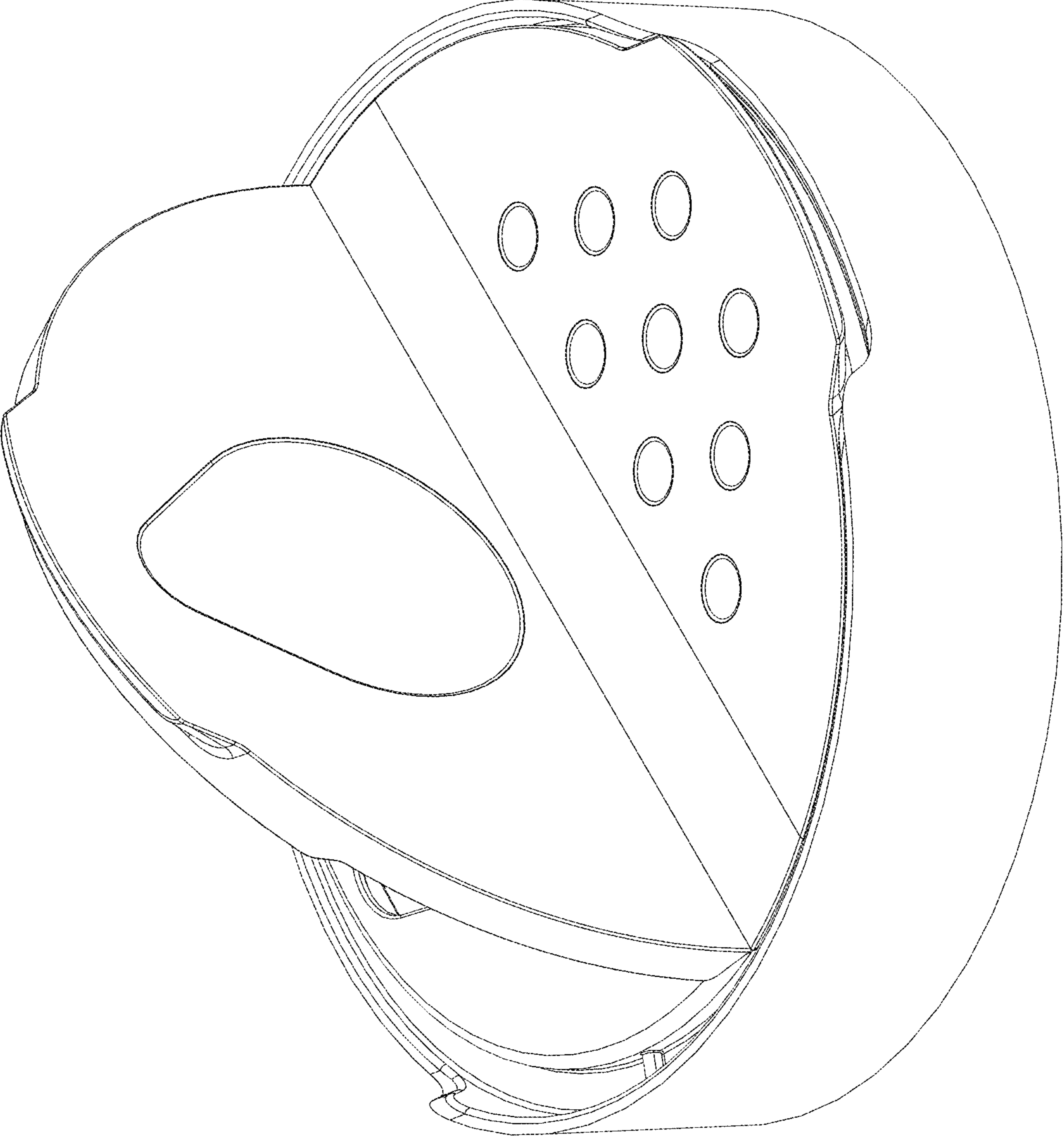

FIG. 10

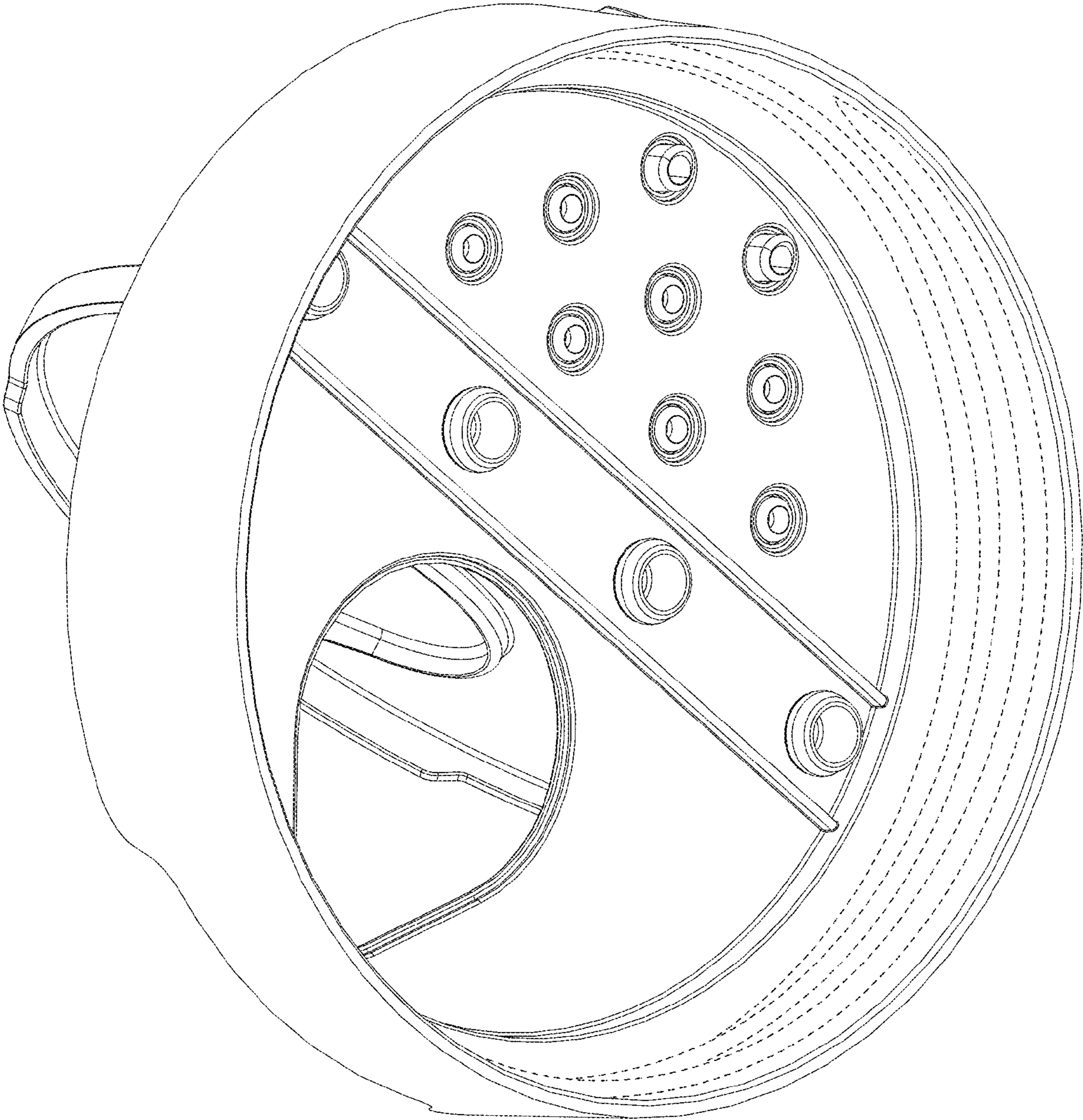

FIG. 11

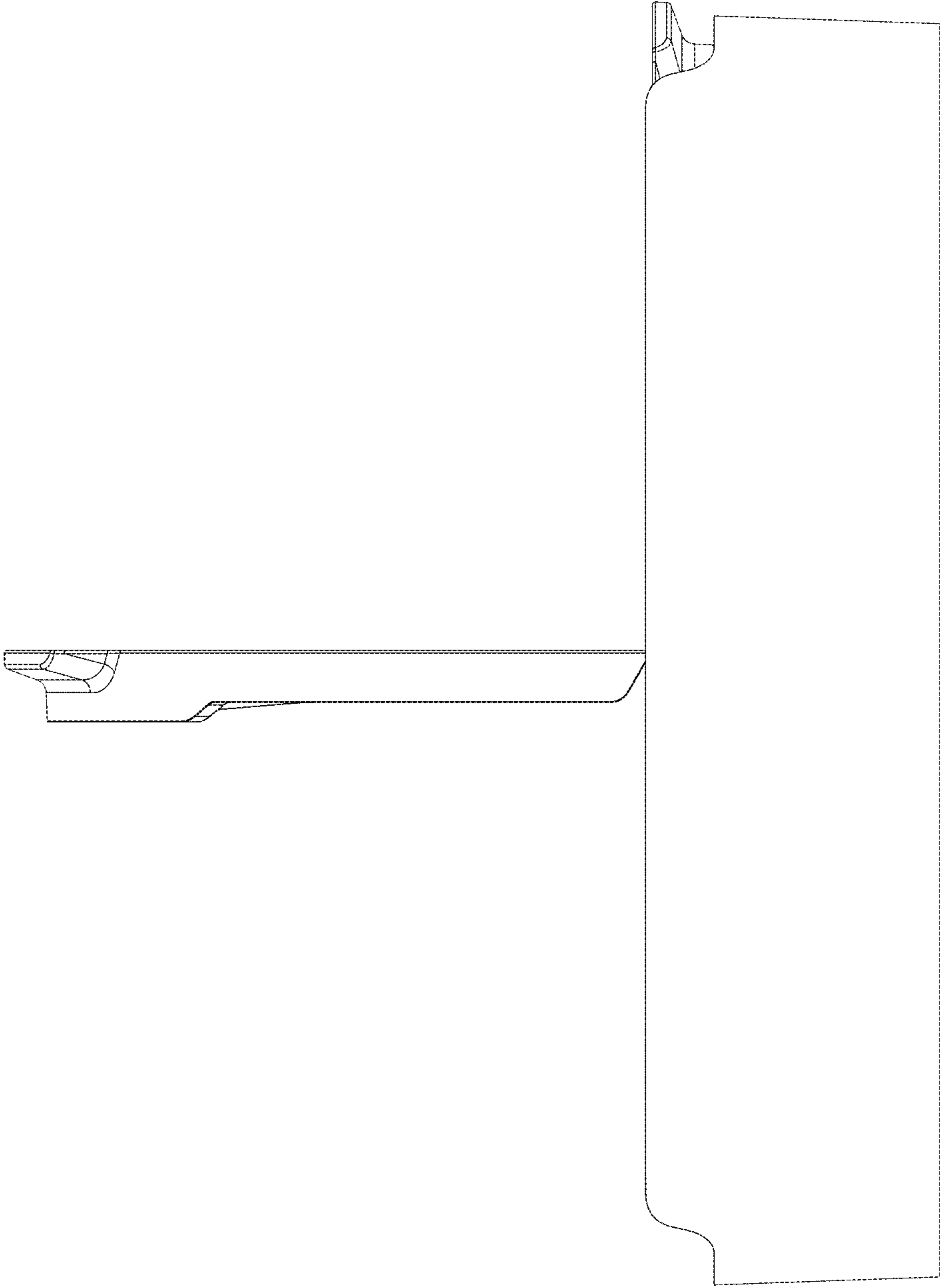

FIG. 12

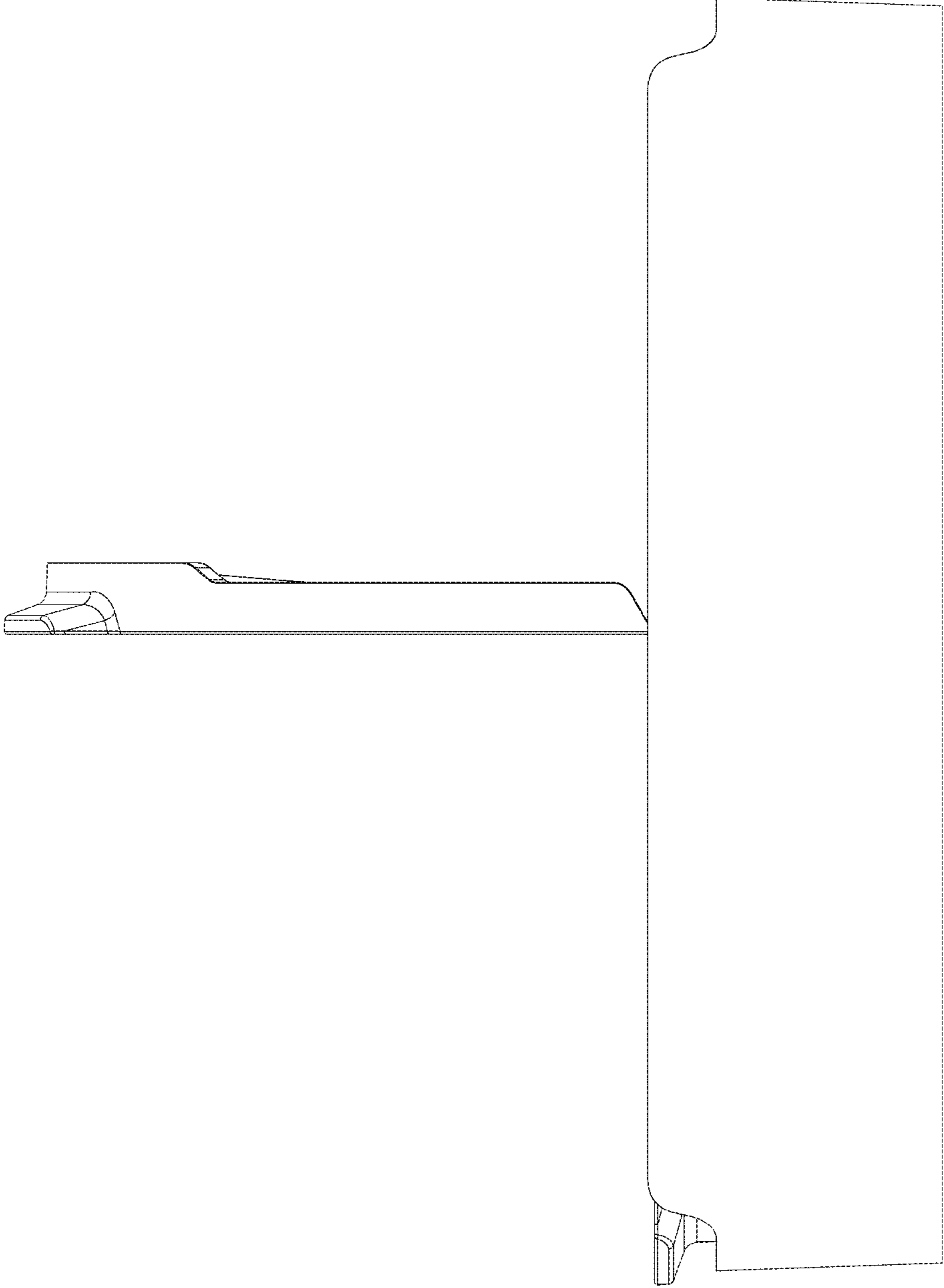

FIG. 13

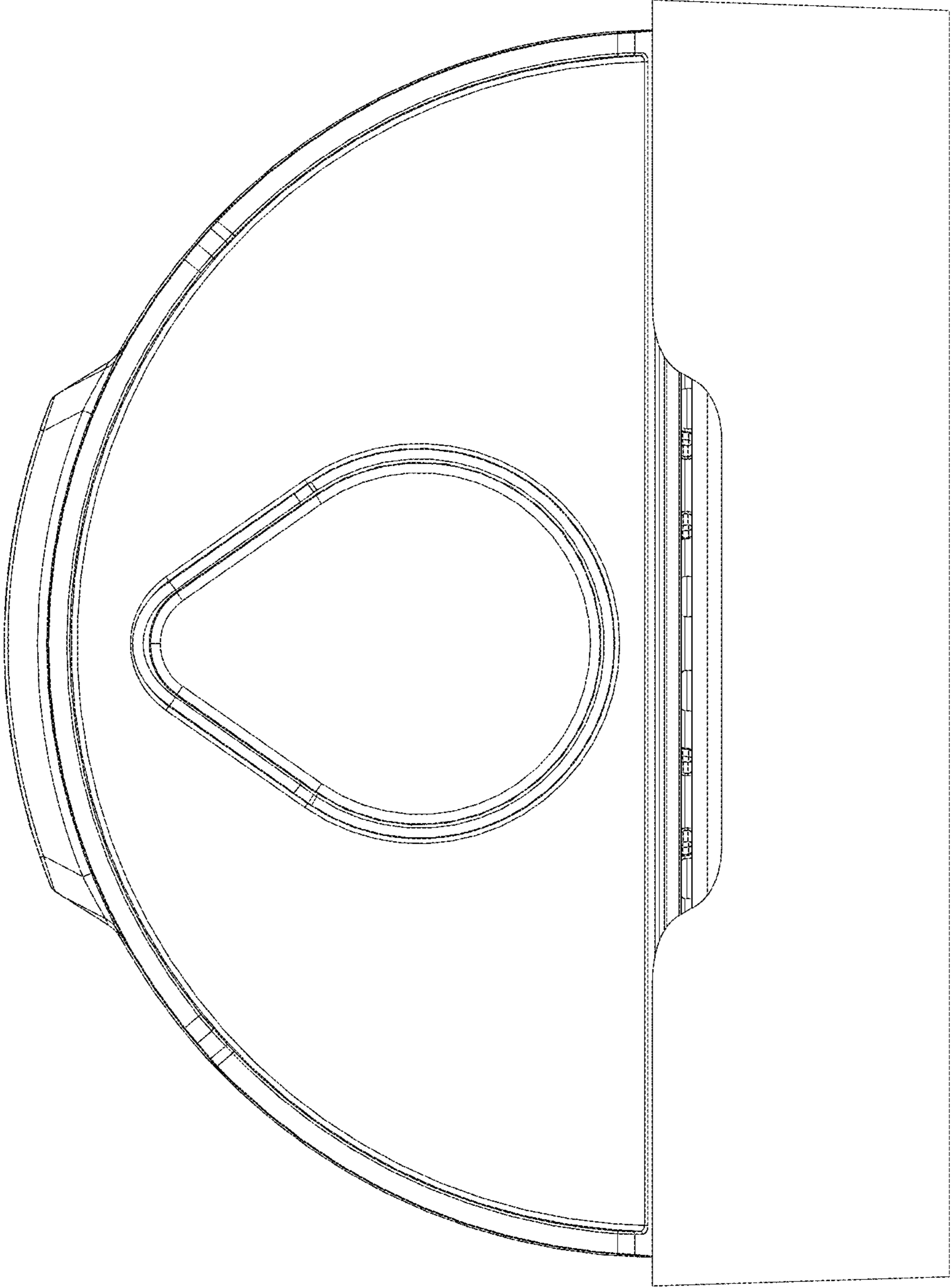

FIG. 14

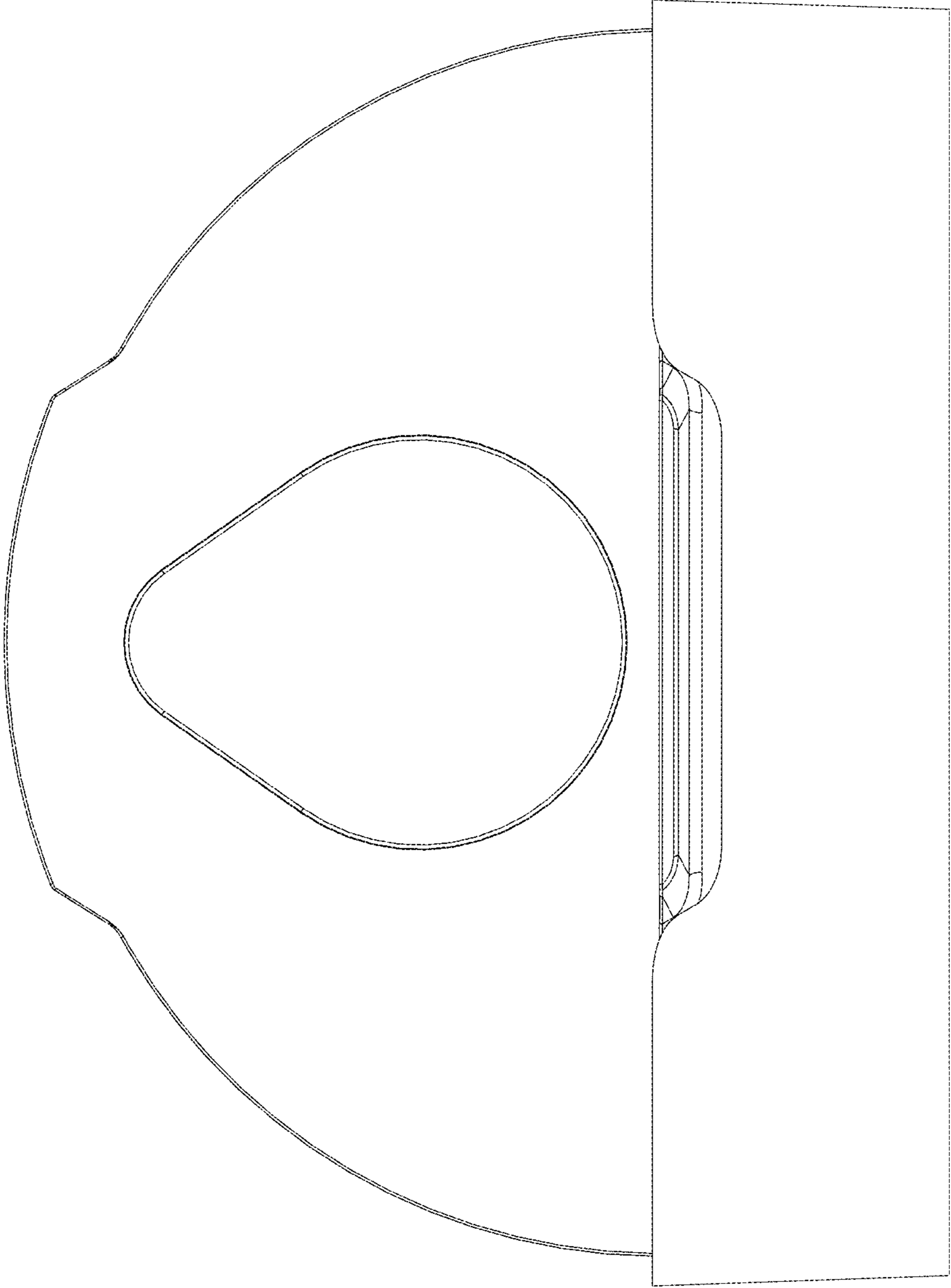

FIG. 15

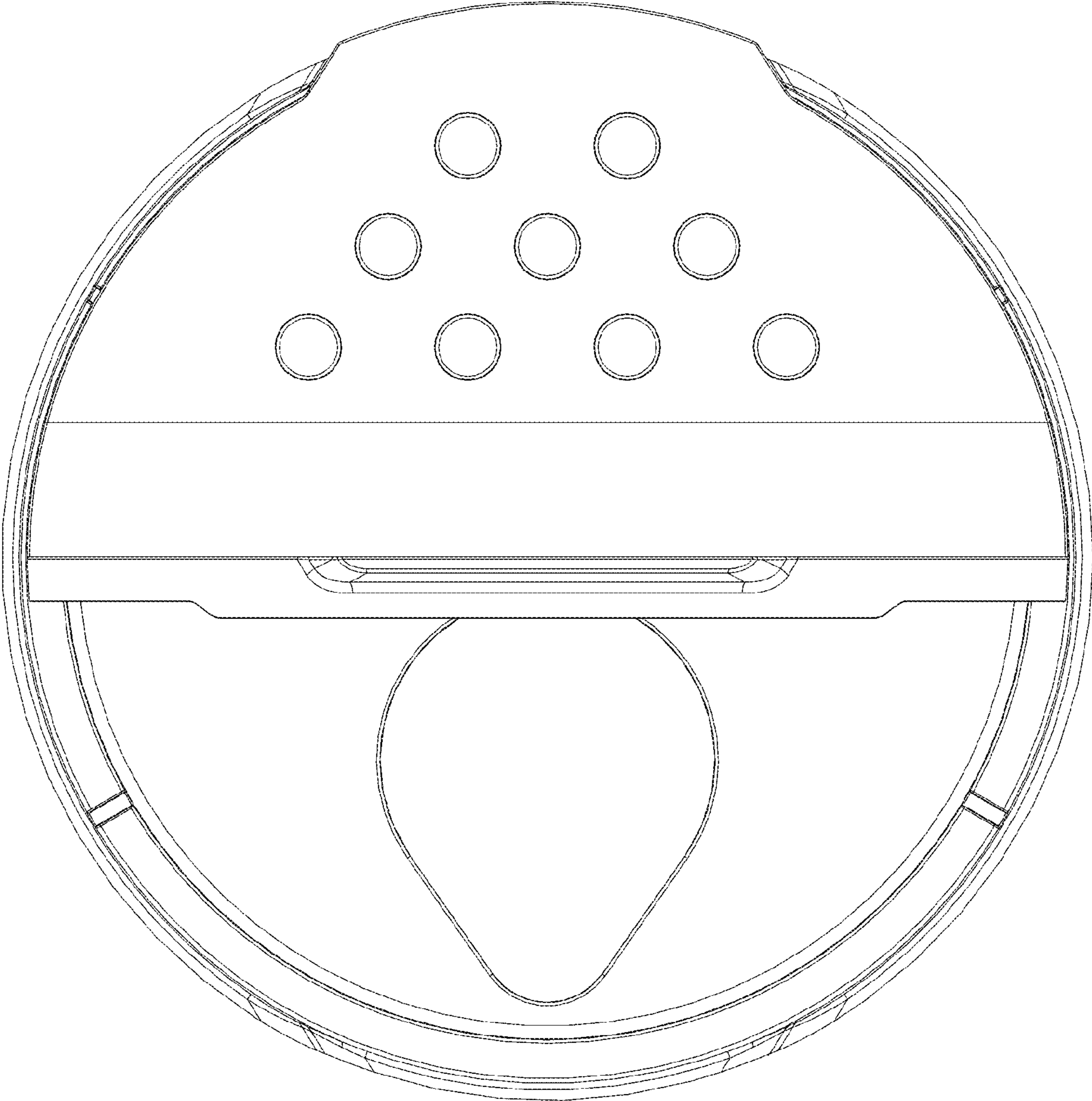

FIG. 16

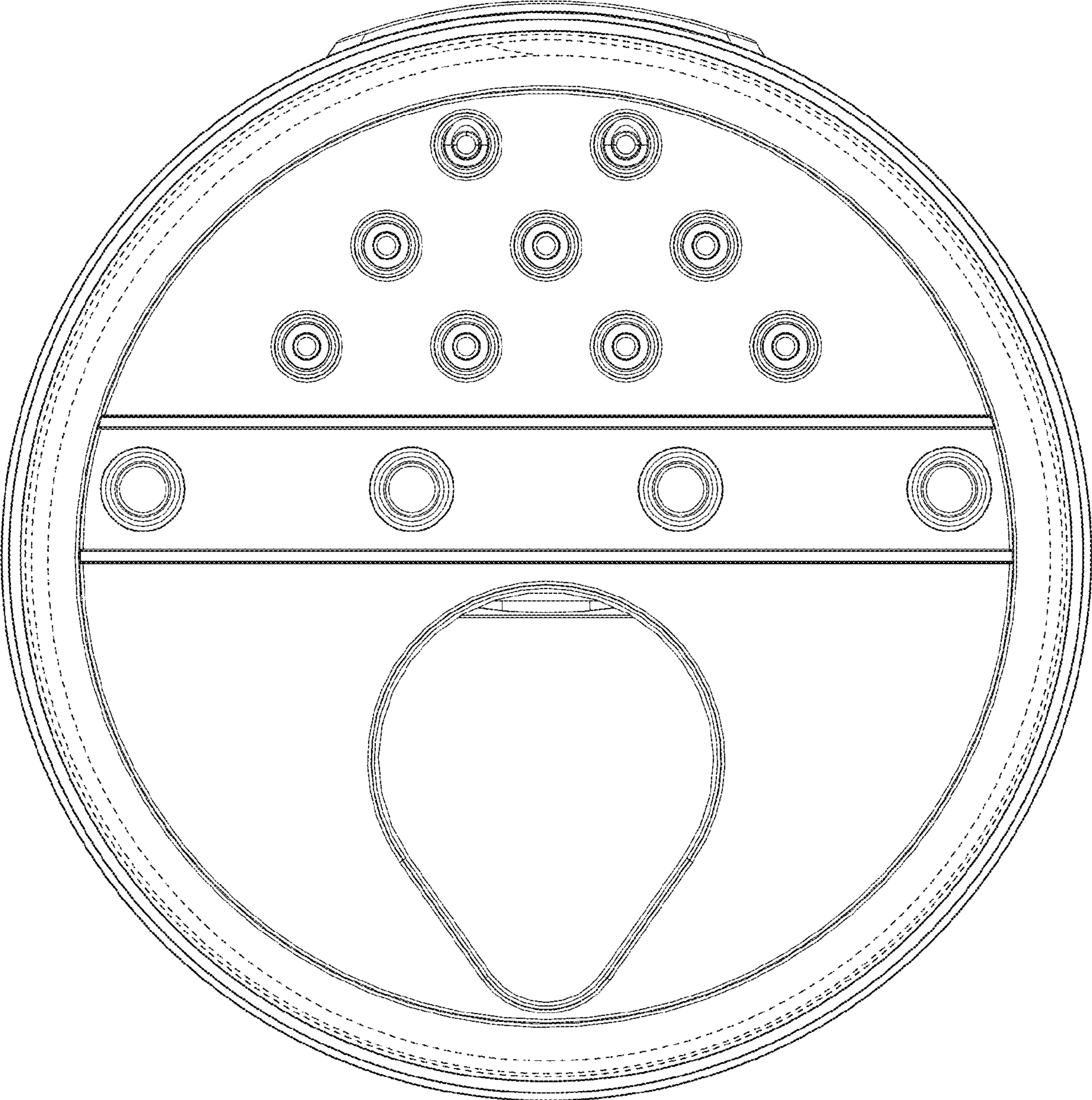

FIG. 17

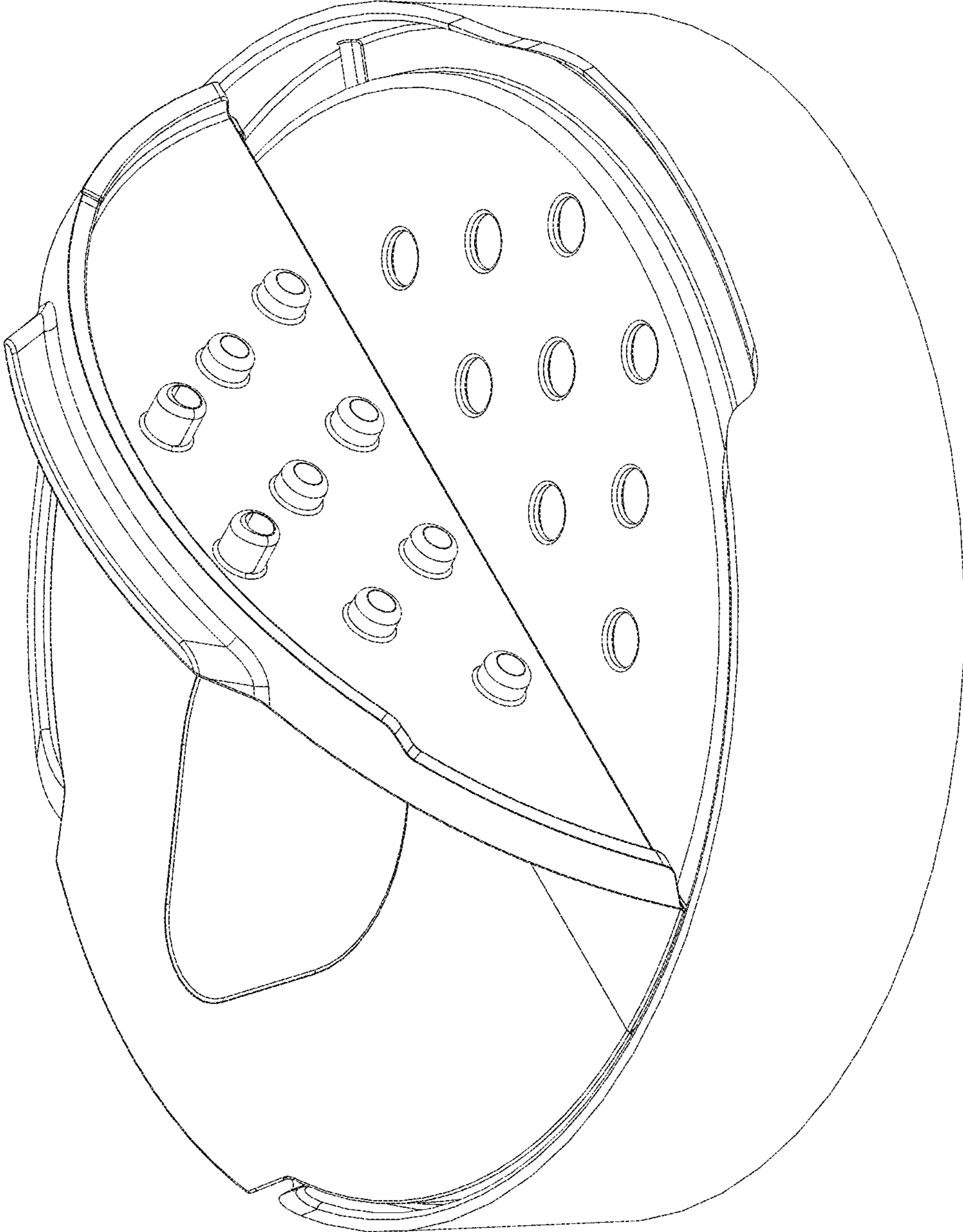

FIG. 18

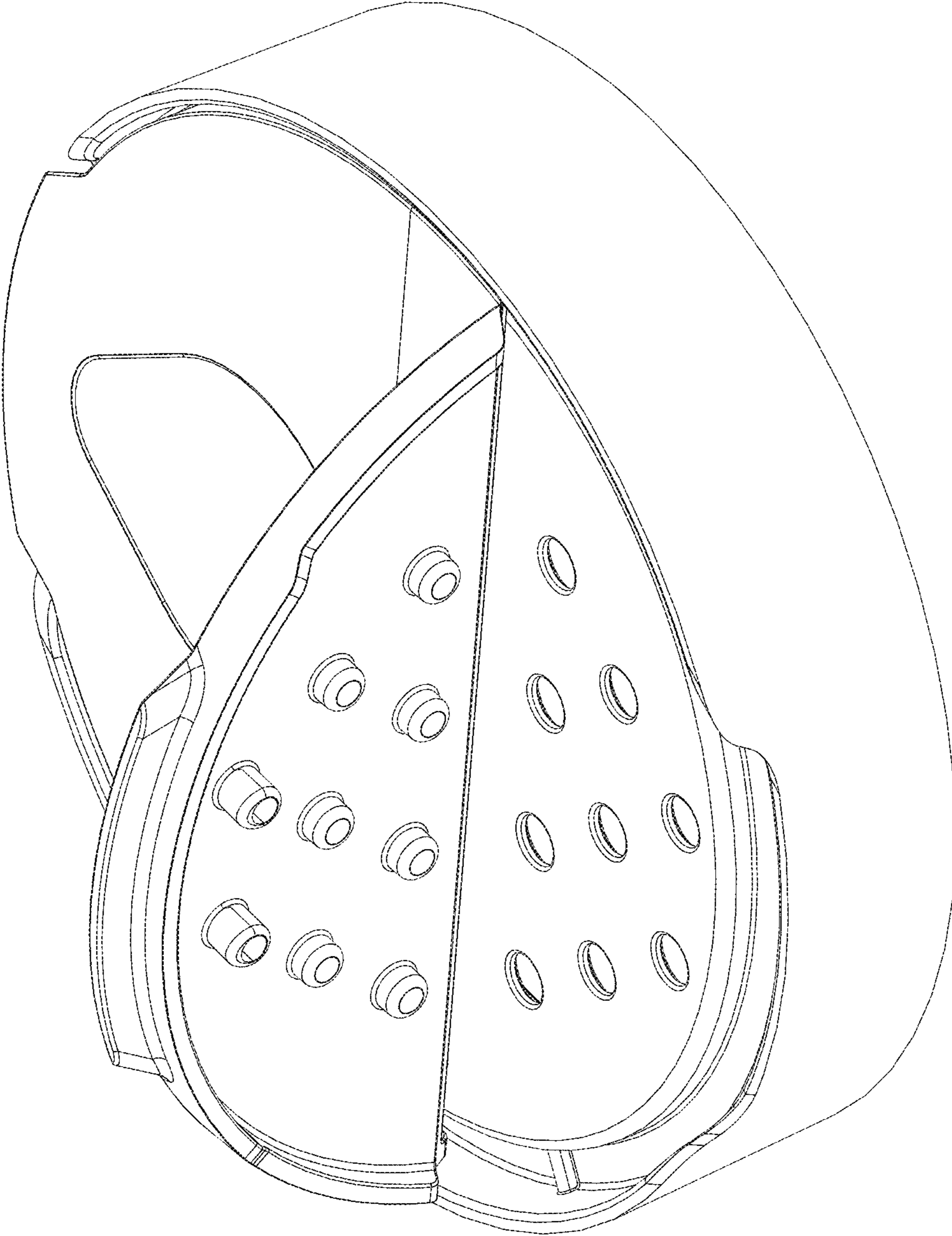

FIG. 19

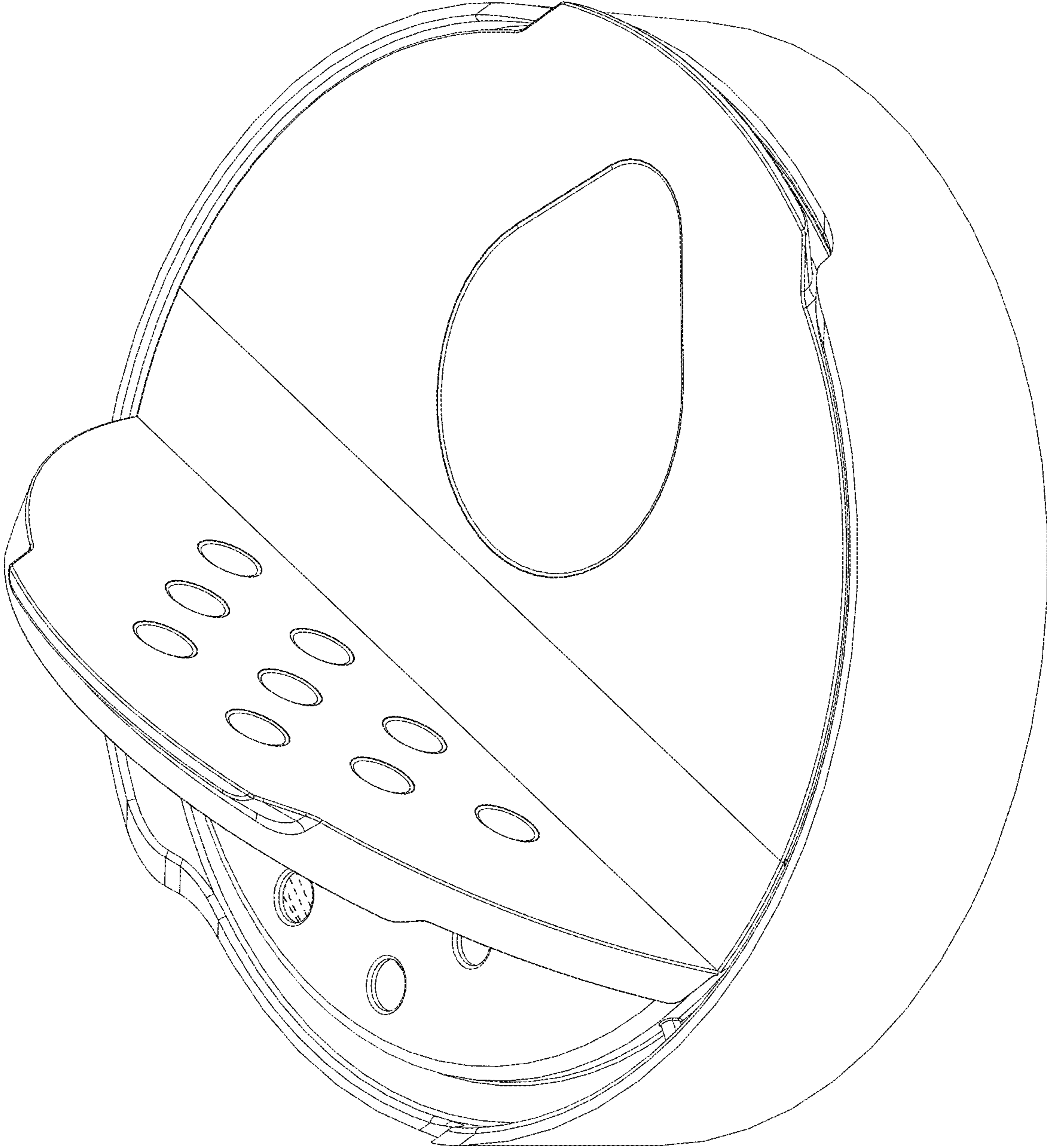

FIG. 20

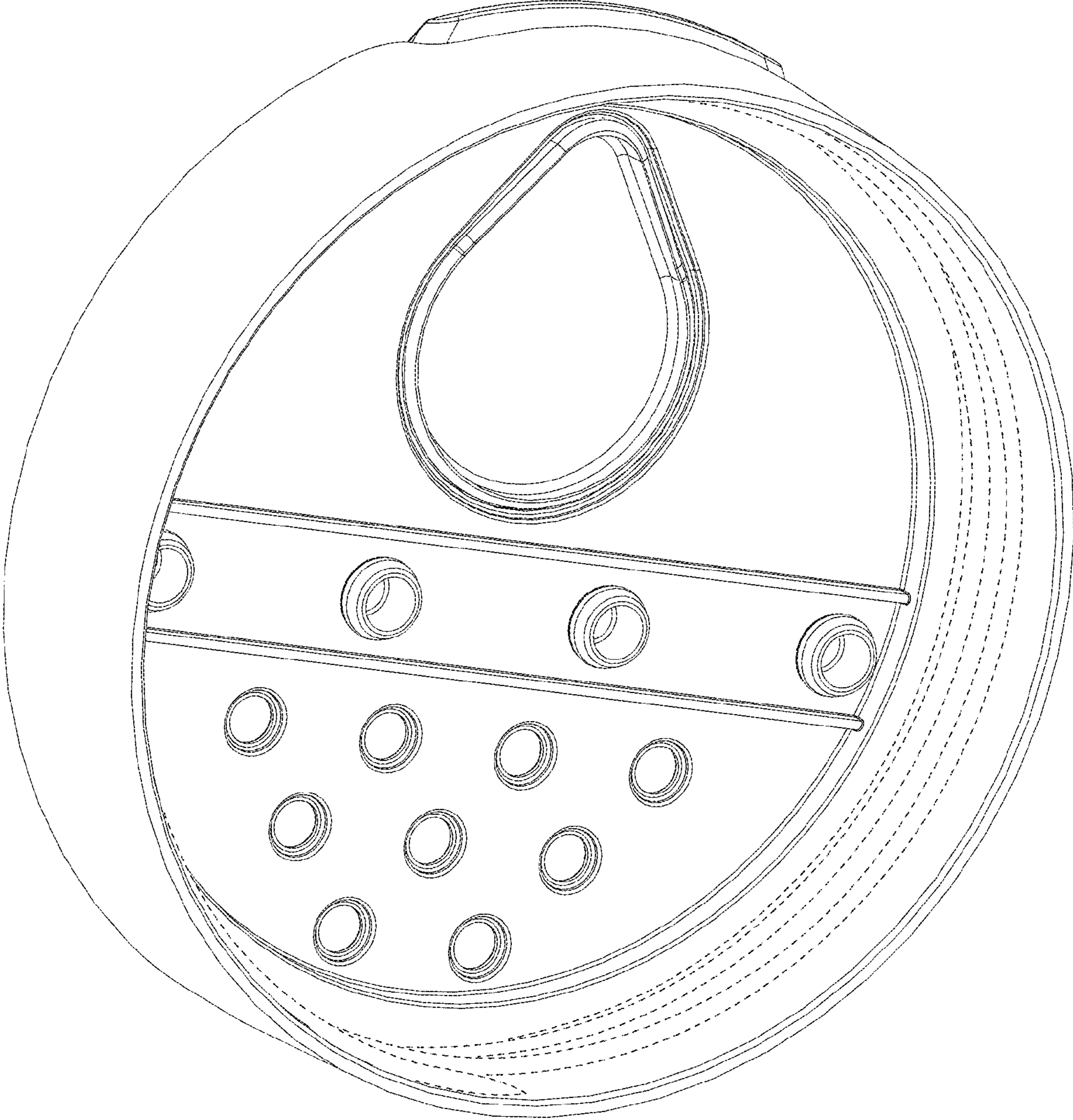

FIG. 21

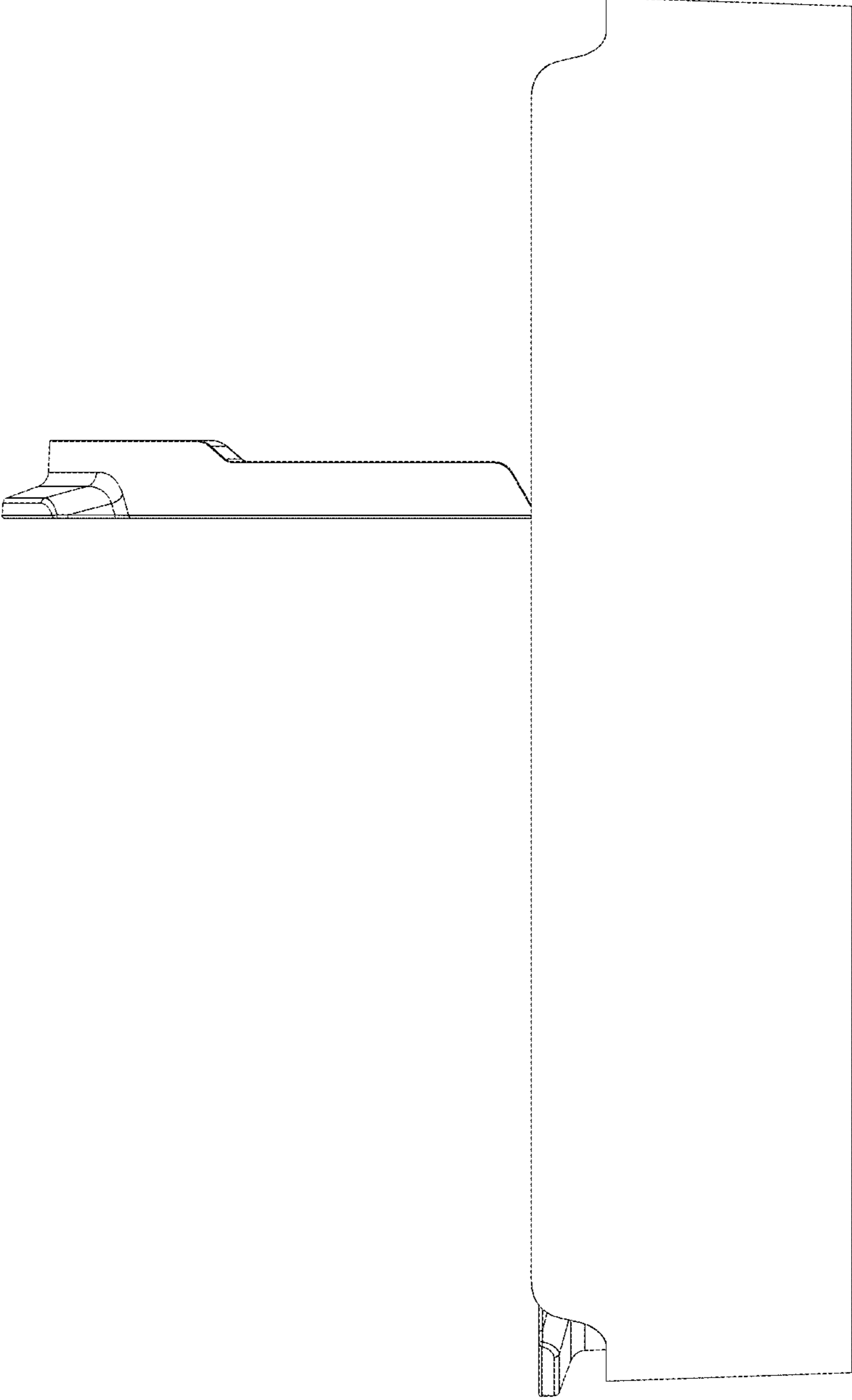

FIG. 22

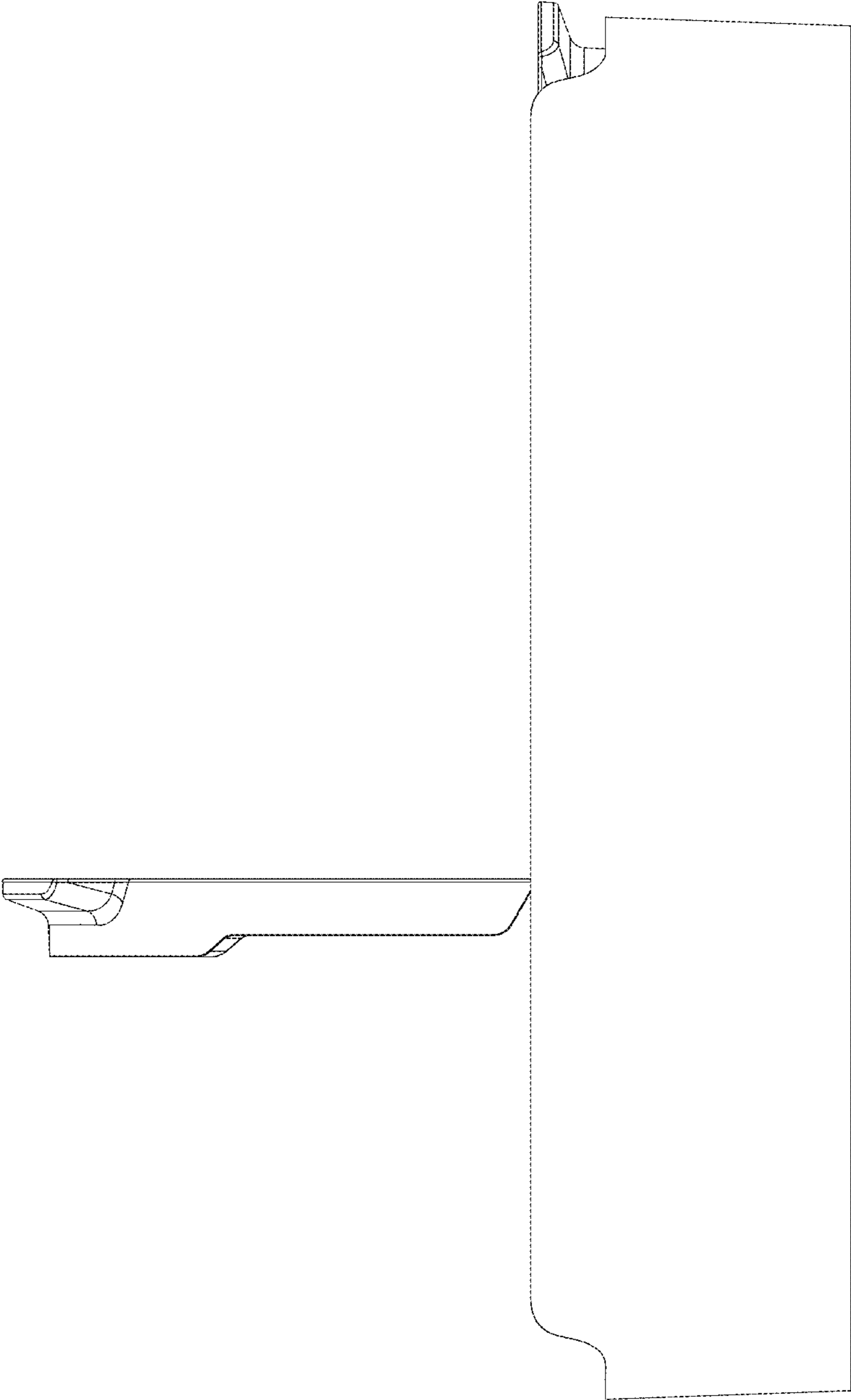

FIG. 23

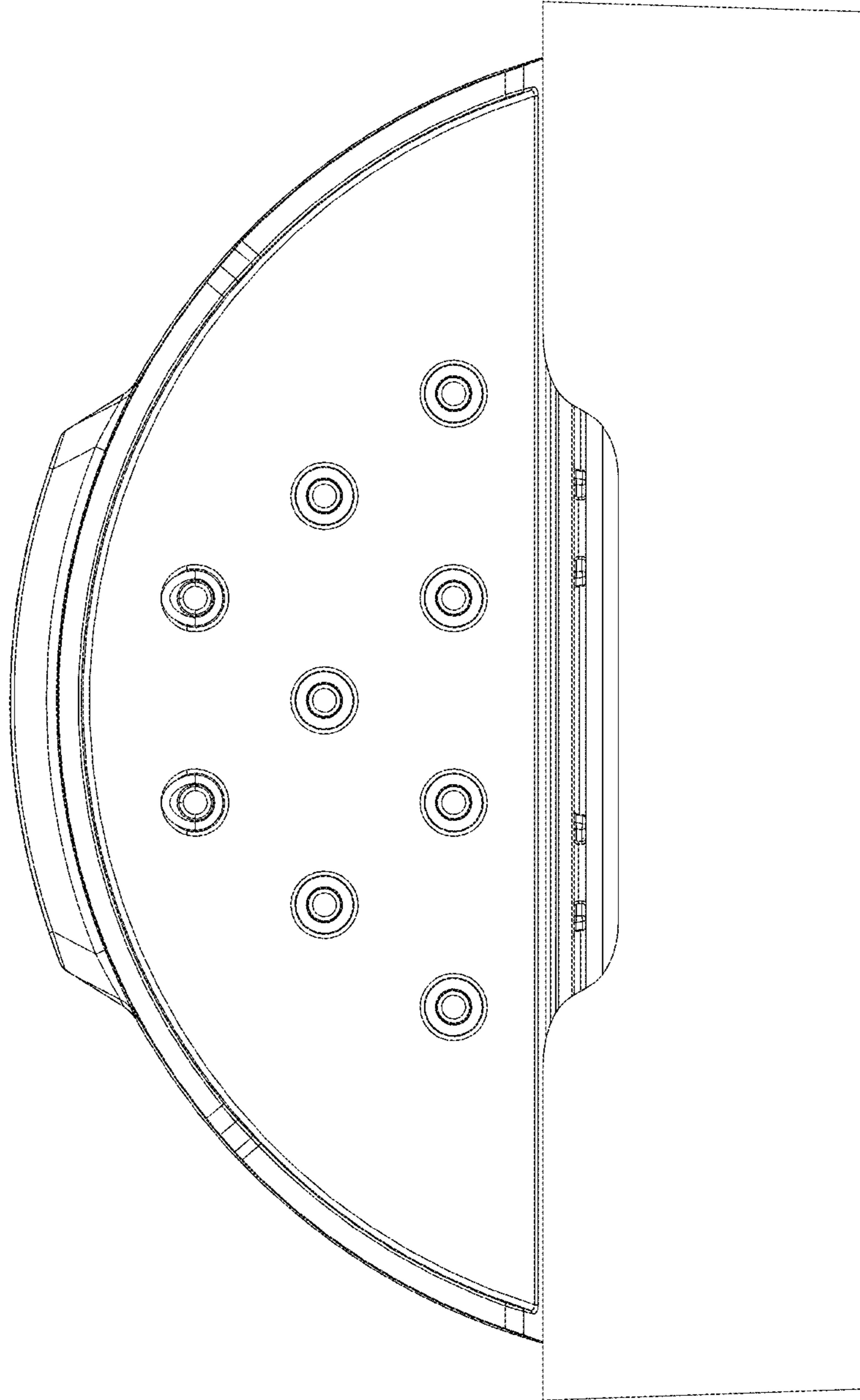

FIG. 24

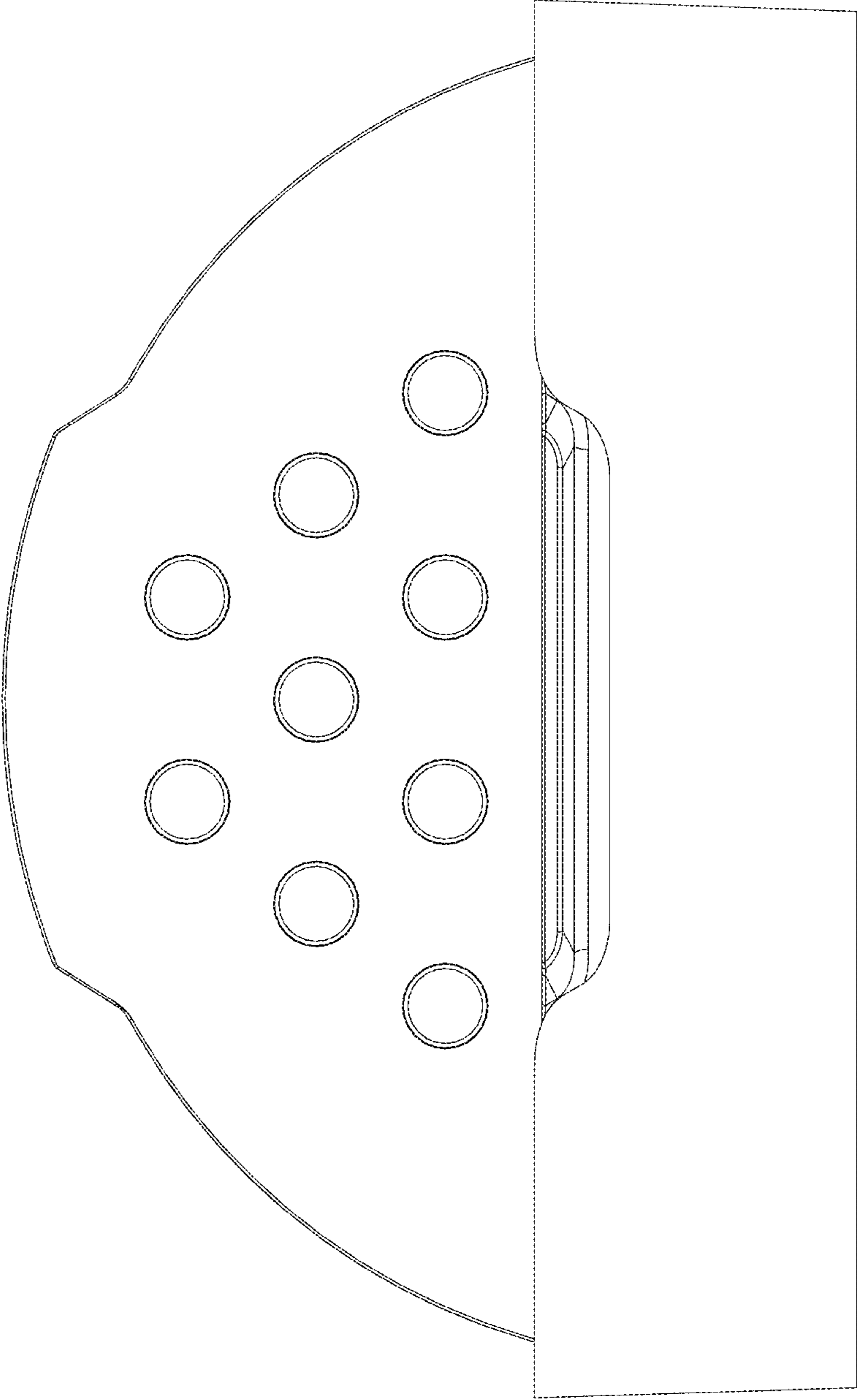

FIG. 25

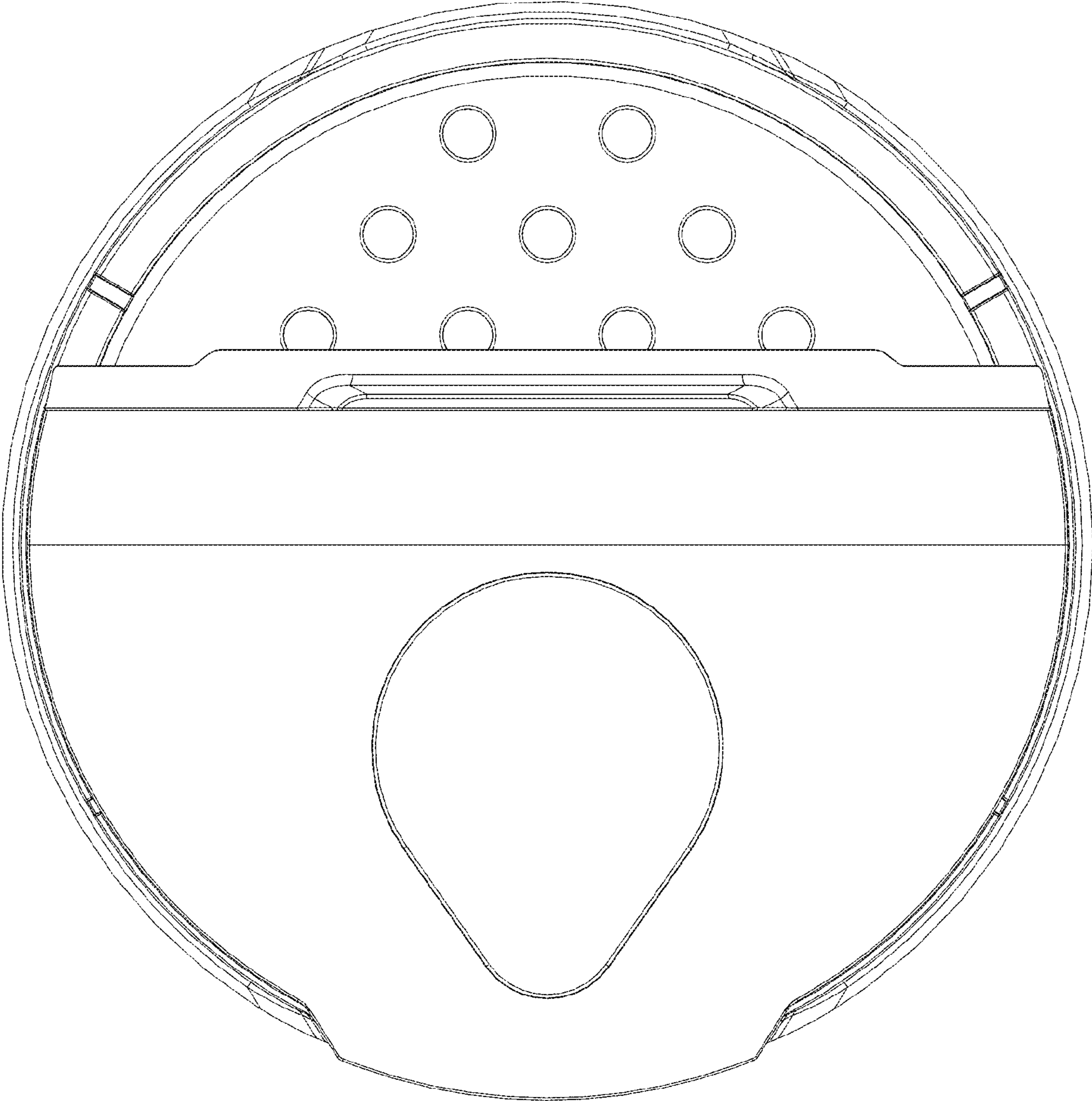

FIG. 26

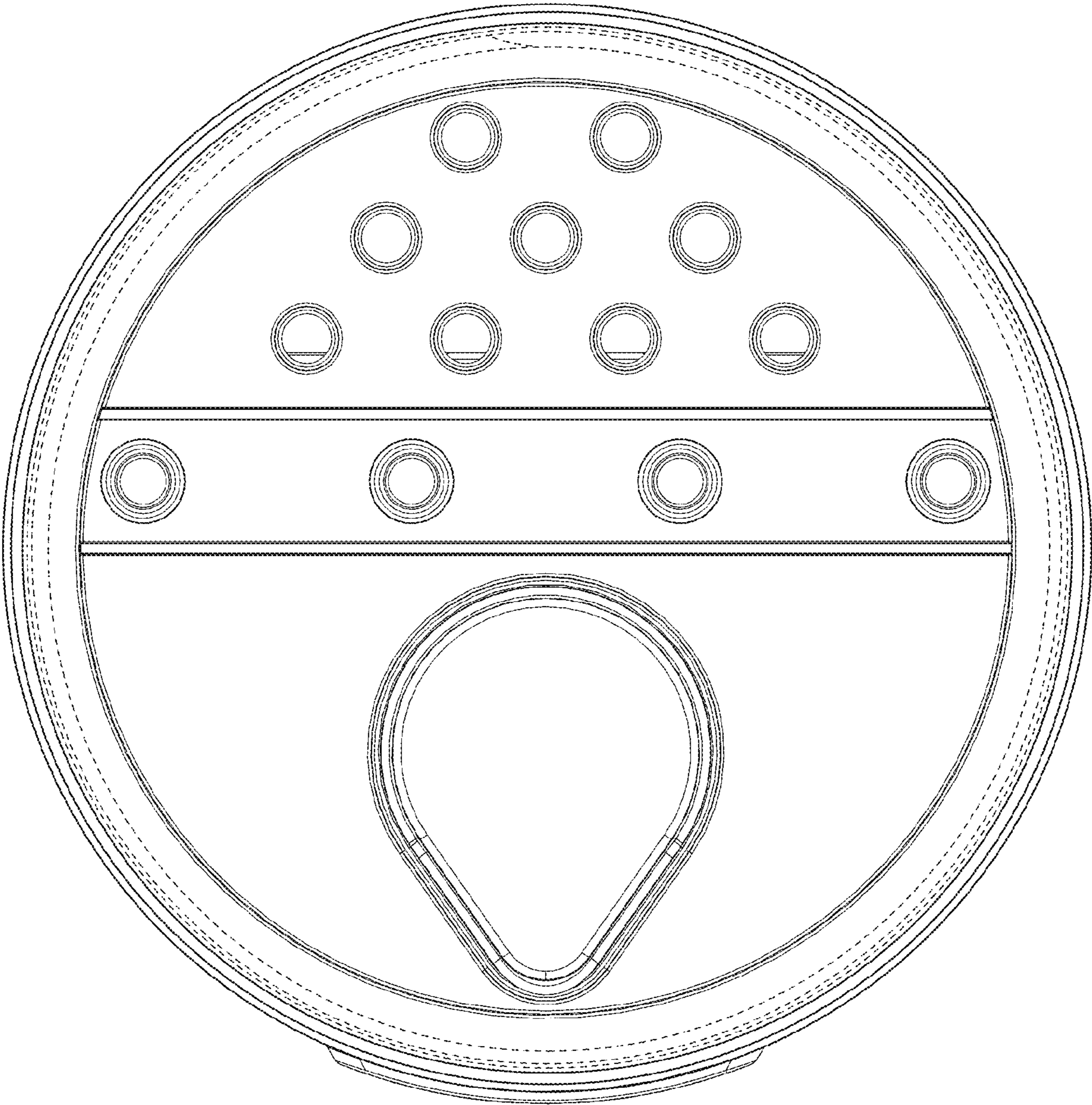

FIG. 27