



US00D900177S

(12) **United States Design Patent** (10) **Patent No.:** **US D900,177 S**
Pappas et al. (45) **Date of Patent:** **** Oct. 27, 2020**

(54) **DRAWER FOR A THREE-DIMENSIONAL PRINTER**

Primary Examiner — Lauren D McVey
(74) *Attorney, Agent, or Firm* — Strategic Patents, P.C.

(71) Applicant: **MakerBot Industries, LLC**, Brooklyn, NY (US)

(57) **CLAIM**

(72) Inventors: **Michael C. Pappas**, Houston, TX (US); **Michael Joseph Kobida**, Lake Barrington, IL (US); **Kevin C. Rand**, Rotterdam (NL); **Vishnu Anantha**, Brooklyn, NY (US)

The ornamental design for a drawer for a three-dimensional printer, as shown and described.

(73) Assignee: **MakerBot Industries, LLC**, Brooklyn, NY (US)

DESCRIPTION

(**) Term: **15 Years**

FIG. 1 is a top perspective view of a design for a drawer for a three-dimensional printer;
FIG. 2 is a rear view thereof;
FIG. 3 is a front view thereof;
FIG. 4 is a right side view thereof;
FIG. 5 is a left side view thereof;
FIG. 6 is a top view thereof;
FIG. 7 is a bottom view thereof;
FIG. 8 is a top perspective view of the design of the drawer for a three-dimensional printer in an open position;
FIG. 9 is a front view of the design of the drawer for a three-dimensional printer in the open position;
FIG. 10 is a left side view of the design of the drawer for a three-dimensional printer in the open position;
FIG. 11 is a right side view of the design of the drawer for a three-dimensional printer in the open position;
FIG. 12 is a top view of the design of the drawer for a three-dimensional printer in the open position;
FIG. 13 is a bottom view of the design of the drawer for a three-dimensional printer in the open position;
FIG. 14 is a top perspective view of the design of the drawer for a three-dimensional printer in an open position;
FIG. 15 is a top perspective view of the design of the drawer for a three-dimensional printer in an open position; and,
FIG. 16 is a top perspective view of the design of the drawer for a three-dimensional printer in a partially-open position.
The broken lines immediately adjacent to the shaded areas and define unshaded regions depict the bounds of the claimed design, while all other broken lines are directed to environment. The broken lines form no part of the claimed design.

(21) Appl. No.: **29/684,148**

(22) Filed: **Mar. 19, 2019**

(51) **LOC (12) Cl.** **15-09**

(52) **U.S. Cl.**
USPC **D15/138**

(58) **Field of Classification Search**
USPC D15/122, 135, 138, 141; D18/14, 19, 50, D18/54, 54.1, 55, 59

(Continued)

(56) **References Cited**

U.S. PATENT DOCUMENTS

2,106,726 A 2/1938 Draeger
2,160,710 A 5/1939 Roehrl

(Continued)

FOREIGN PATENT DOCUMENTS

CN 304913265 * 11/2018

OTHER PUBLICATIONS

Kickstarter. Link: <https://www.kickstarter.com/projects/filasafe/filasafe-the-industrial-3d-printer-filament-holder>. Oct. 15, 2019. FilaSAFE Created by Wali Labs. (Year: 2019).*

(Continued)

1 Claim, 12 Drawing Sheets

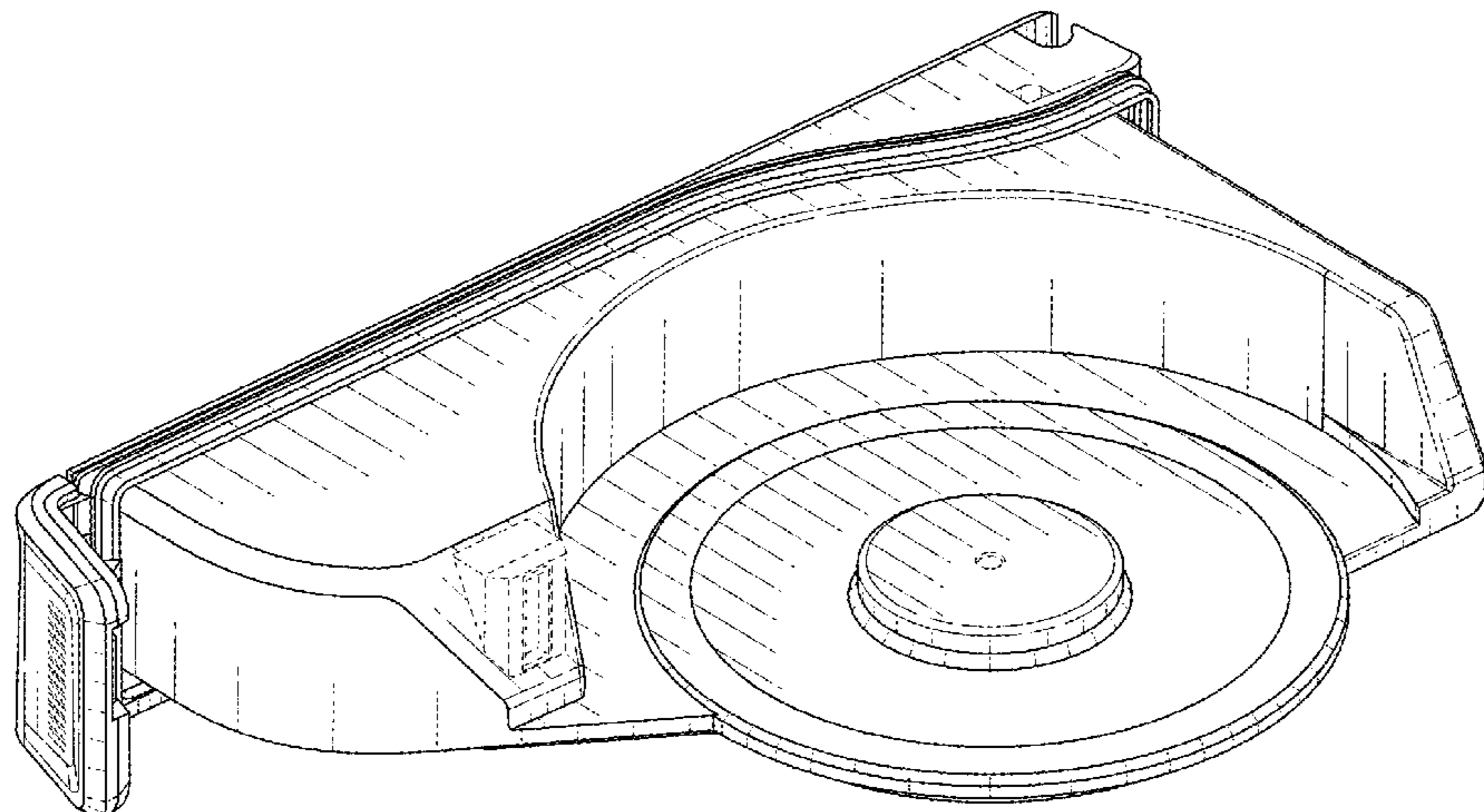

(58) **Field of Classification Search**

CPC B22F 3/105; B22F 3/008; B29C 35/00;
 B29C 35/02; B29C 35/04; B29C 35/06;
 B29C 35/08; B29C 35/10; B29C 35/12;
 B29C 35/14; B29C 35/16; B29C 35/18;
 B29C 37/00; B29C 37/02; B29C 37/04;
 B29C 67/00; B29C 67/02; B29C 67/04;
 B29C 67/06; B29C 67/08; B29C 67/20;
 B29C 67/24; B29C 69/00; B29C 69/02;
 B29C 70/00; B29C 70/02; B29C 70/04;
 B29C 70/06; B29C 70/08; B29C 70/10;
 B29C 70/12; B29C 70/14; B29C 70/16;
 B29C 70/18; B29C 70/20; B29C 70/22;
 B29C 70/24; B29C 70/26; B29C 70/28;
 B29C 41/12; B29C 41/36; B29C 67/0081;
 B41J 2/155; B41J 2/17513; B41J
 2/17556; B41J 2/17596; B41J 2/16552;
 B41J 2/16541; B41J 2002/20; B41J
 2002/14475; B29K 2995/0021

See application file for complete search history.

(56)

References Cited

U.S. PATENT DOCUMENTS

3,279,590 A 10/1966 Gould et al.
 3,356,311 A 12/1967 Winkler et al.
 D210,172 S 2/1968 Roman
 D212,761 S 11/1968 Gelardi et al.
 D215,360 S 9/1969 Bundschuh
 D217,303 S 4/1970 Ainslie et al.
 D230,991 S 3/1974 Catto et al.
 3,951,264 A 4/1976 Heidecker et al.
 4,015,790 A * 4/1977 Gelardi G11B 23/07
 242/326.3
 D260,514 S 9/1981 Gell
 4,320,422 A * 3/1982 Rinkleib G11B 23/042
 360/132
 D264,340 S 5/1982 Iftikar et al.
 D264,842 S 6/1982 Daniels et al.
 D266,670 S 10/1982 West
 D270,055 S 8/1983 Irwin et al.
 D270,348 S 8/1983 Irwin et al.
 D276,527 S 11/1984 Flanigan
 D281,321 S 11/1985 Wright
 4,561,085 A 12/1985 Funabashi et al.
 D282,357 S 1/1986 Gell
 4,608,617 A 8/1986 Oishi et al.
 D286,879 S 11/1986 Viskochil
 4,773,614 A 9/1988 Makino et al.
 5,011,010 A 4/1991 Francis et al.
 5,139,210 A 8/1992 Schaffer et al.
 5,174,520 A 12/1992 Iwahashi et al.
 5,279,473 A 1/1994 Rozon et al.
 D358,141 S 5/1995 Pecone et al.
 D366,471 S 1/1996 Ito et al.
 D367,278 S 2/1996 Moriwaki et al.
 5,492,284 A 2/1996 Sorensen et al.
 5,586,651 A 12/1996 Krummenacher et al.
 5,590,769 A 1/1997 Lin
 D385,261 S 10/1997 Akiba
 5,762,281 A 6/1998 Foley et al.
 D413,115 S * 8/1999 Schick D14/435
 D418,128 S 12/1999 Ellis et al.
 D424,551 S 5/2000 Harata
 6,074,583 A 6/2000 Ingram
 D434,394 S 11/2000 Hsieh
 D436,111 S 1/2001 Hahn et al.
 6,280,103 B1 8/2001 Zawodny et al.
 D458,674 S 6/2002 Ropponen
 D459,465 S 6/2002 Ropponen
 6,398,146 B1 6/2002 Cattaneo et al.
 6,446,799 B1 9/2002 Simba et al.
 D476,663 S * 7/2003 Nonomura D14/483

D481,034 S 10/2003 Okano et al.
 D483,754 S * 12/2003 Ueno D14/260.1
 D486,906 S 2/2004 Xiao et al.
 D488,857 S 4/2004 Wintersteen et al.
 D493,462 S 7/2004 Wang
 D495,690 S 9/2004 Lin
 D497,164 S 10/2004 Wang
 D502,941 S 3/2005 Nakata et al.
 6,896,132 B1 5/2005 Frick et al.
 D506,997 S 7/2005 Matsui et al.
 6,945,298 B2 9/2005 Ludvigsen
 7,063,285 B1 6/2006 Turley et al.
 D536,730 S * 2/2007 Blanchard, Jr. D18/50
 D542,290 S 5/2007 Hosoya
 D542,838 S * 5/2007 Blanchard, Jr. D18/50
 D572,252 S 7/2008 Kuo et al.
 D585,899 S * 2/2009 Shek D14/435
 D598,922 S 8/2009 Taatjes et al.
 7,571,872 B2 8/2009 Shiga et al.
 7,578,464 B2 8/2009 Sasaki et al.
 D606,998 S 12/2009 Taatjes et al.
 7,658,282 B2 2/2010 Costel et al.
 D633,916 S 3/2011 Taatjes et al.
 D647,127 S * 10/2011 Mita D18/12
 D650,787 S 12/2011 Taatjes et al.
 D651,392 S 1/2012 De Lima
 D723,561 S 3/2015 Buel et al.
 D737,347 S 8/2015 Anantha et al.
 D747,374 S 1/2016 Anantha et al.
 D815,166 S * 4/2018 Kato D15/141
 D853,456 S * 7/2019 Aizawa D15/138
 D858,591 S * 9/2019 Koch D15/122
 D861,759 S * 10/2019 Bloom D15/150
 2001/0030383 A1 10/2001 Swanson et al.
 2002/0047063 A1 4/2002 Kaneda et al.
 2002/0139885 A1 10/2002 Watson et al.
 2002/0195364 A1 12/2002 Grcic et al.
 2003/0058778 A1 3/2003 Lin et al.
 2003/0122027 A1 7/2003 Bootsman et al.
 2004/0052192 A1 3/2004 Chen et al.
 2004/0052193 A1 3/2004 Hsieh et al.
 2004/0136845 A1 7/2004 Hsieh et al.
 2004/0194118 A1 9/2004 Chang et al.
 2005/0039201 A1 2/2005 Hsu et al.
 2005/0044556 A1 2/2005 Hsu et al.
 2005/0095126 A1 5/2005 Chang et al.
 2005/0224377 A1 10/2005 Lammerant et al.
 2006/0245922 A1 11/2006 Hsu et al.
 2007/0001050 A1 1/2007 Taatjes et al.
 2007/0094818 A1 5/2007 Lee et al.
 2007/0163901 A1 7/2007 Husmann et al.
 2007/0284270 A1 12/2007 Huang et al.
 2008/0019825 A1 1/2008 Chang et al.
 2008/0152479 A1 6/2008 Horng et al.
 2008/0202957 A1 8/2008 Lacko et al.
 2008/0265078 A1 10/2008 Shiga et al.
 2010/0028144 A1 2/2010 Hung et al.
 2010/0096485 A1 4/2010 Taatjes et al.
 2010/0096489 A1 4/2010 Taatjes et al.
 2010/0230528 A1 9/2010 Singleton et al.
 2010/0232948 A1 9/2010 Horng et al.
 2010/0243784 A1 9/2010 Johanson et al.
 2010/0275560 A1 11/2010 Chen et al.
 2011/0108251 A1 5/2011 Horng et al.
 2011/0174915 A1 7/2011 Taatjes et al.
 2011/0194930 A1 8/2011 Ai et al.
 2012/0012689 A1 1/2012 Alden et al.
 2012/0207618 A1 8/2012 Horng et al.
 2012/0234961 A1 9/2012 Harnage et al.
 2014/0030075 A1 1/2014 Chen et al.
 2014/0127009 A1 5/2014 Fujinawa et al.
 2014/0161602 A1 6/2014 Schmidt et al.
 2014/0161653 A1 6/2014 Chung et al.
 2015/0043225 A1 2/2015 Goodman et al.

OTHER PUBLICATIONS

“U.S. Appl. No. 29/485,355, Non-Final Office Action dated May 21, 2015”, 13 pages.

(56)

References Cited

OTHER PUBLICATIONS

“U.S. Appl. No. 29/485,355, Notice of Allowance dated Sep. 2, 2015”, 6 pages.

“U.S. Appl. No. 29/478,424, Notice of Allowance dated May 21, 2015”, 14 pages.

* cited by examiner

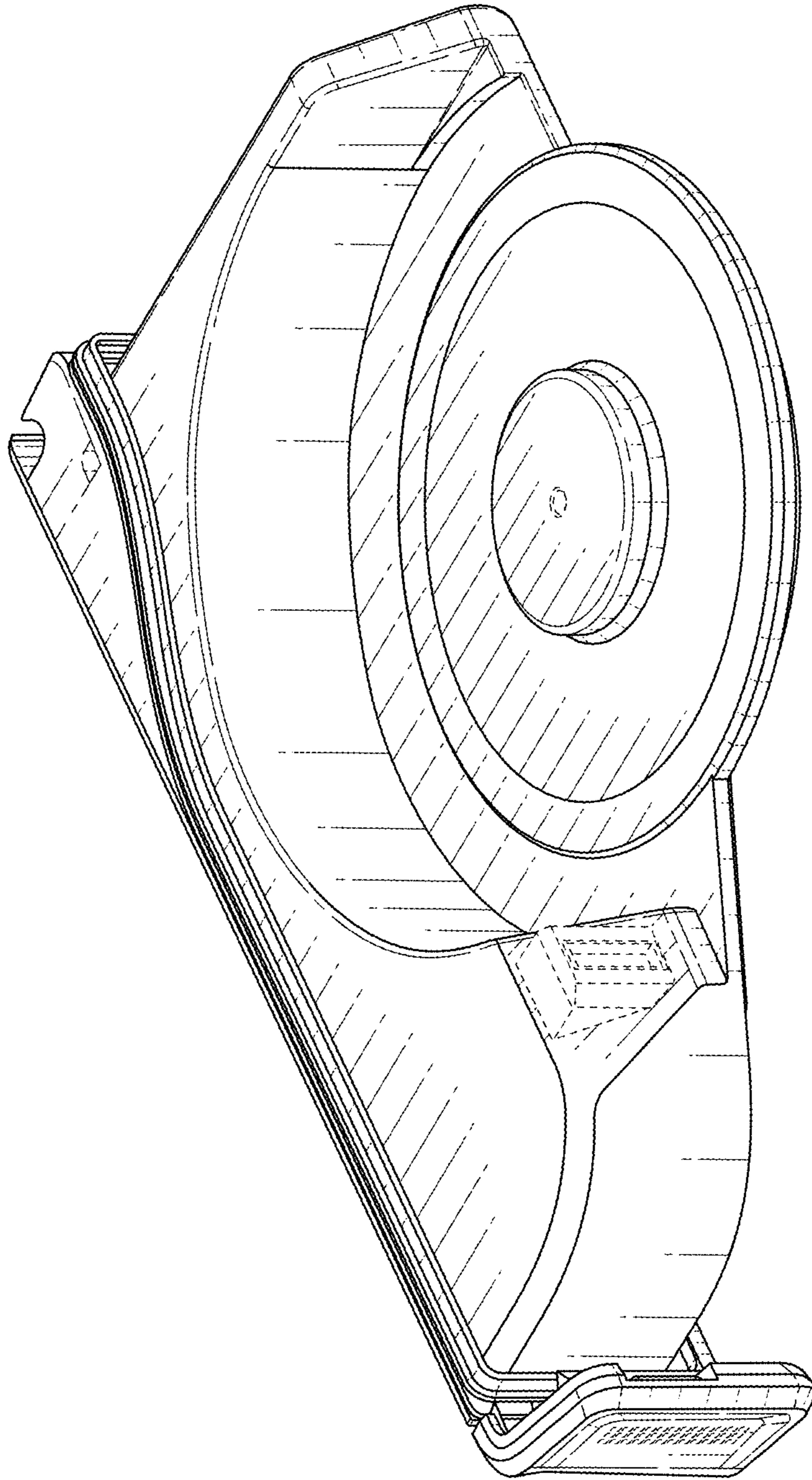

FIG. 1

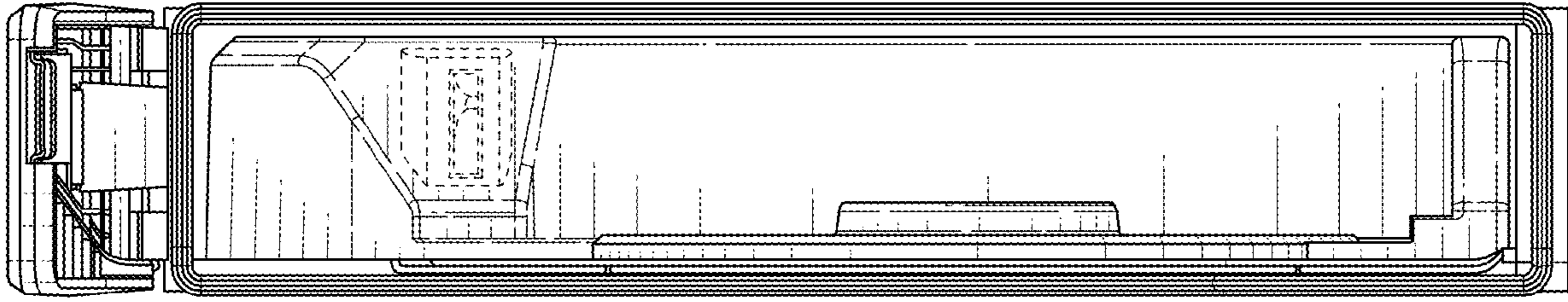

FIG. 2

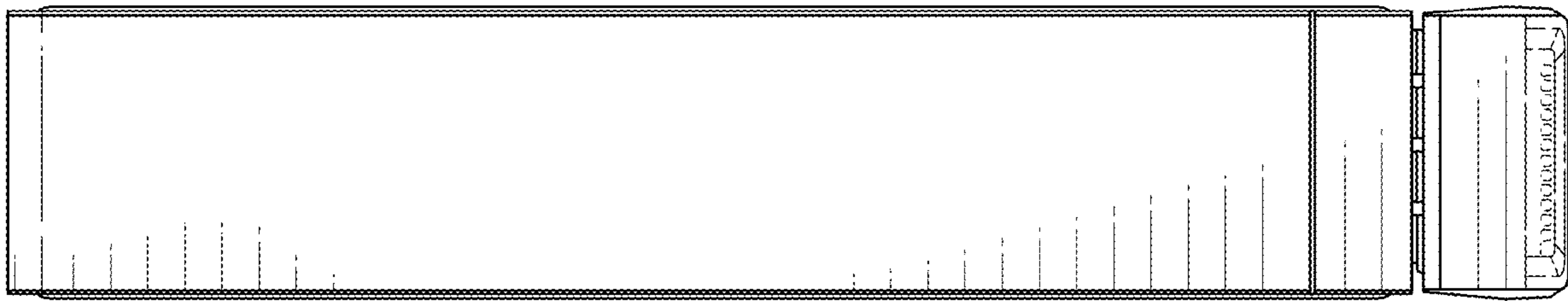

FIG. 3

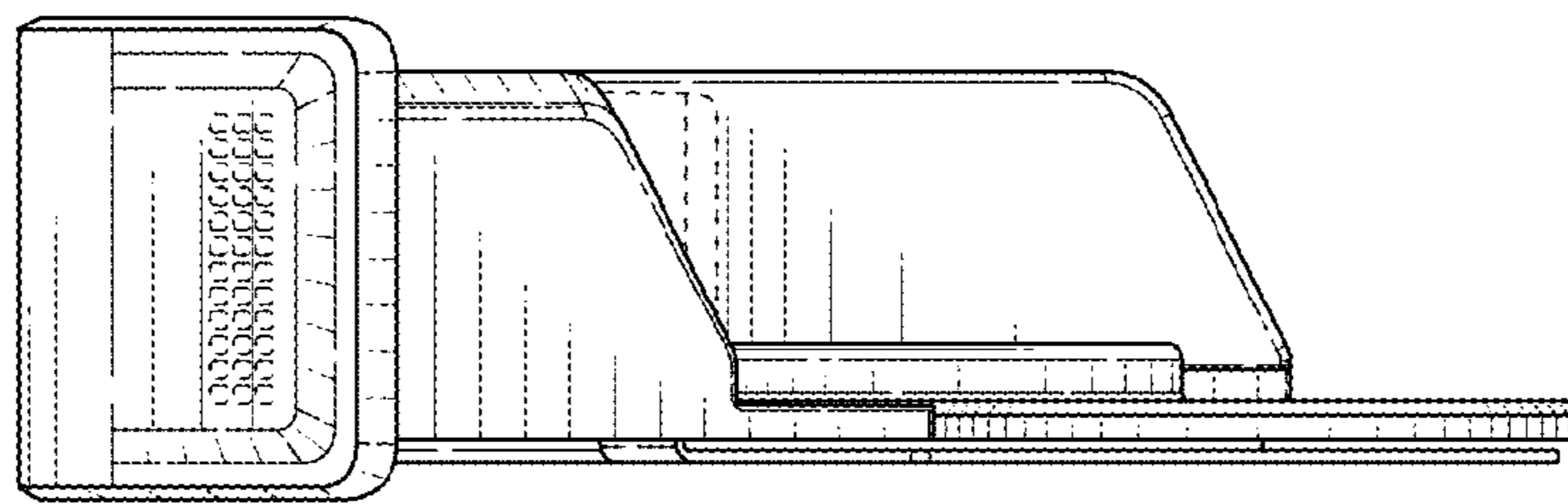

FIG. 4

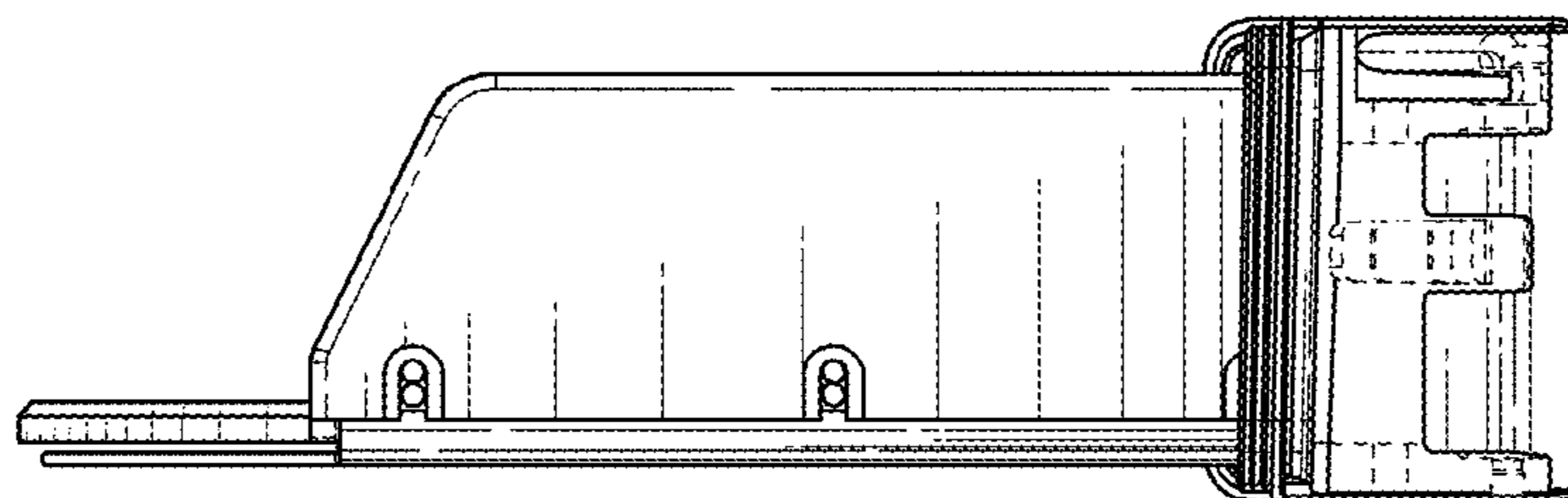

FIG. 5

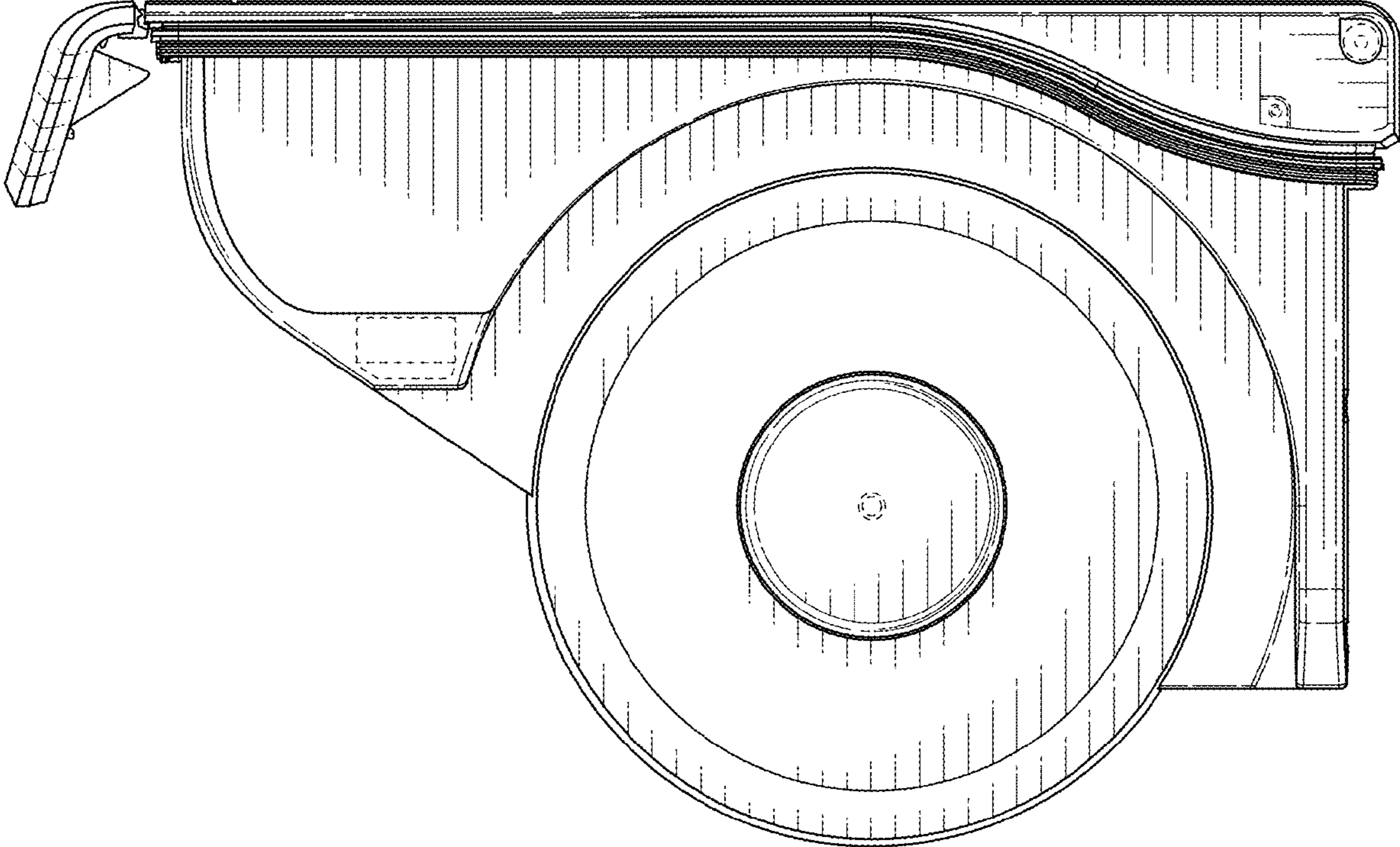

FIG. 6

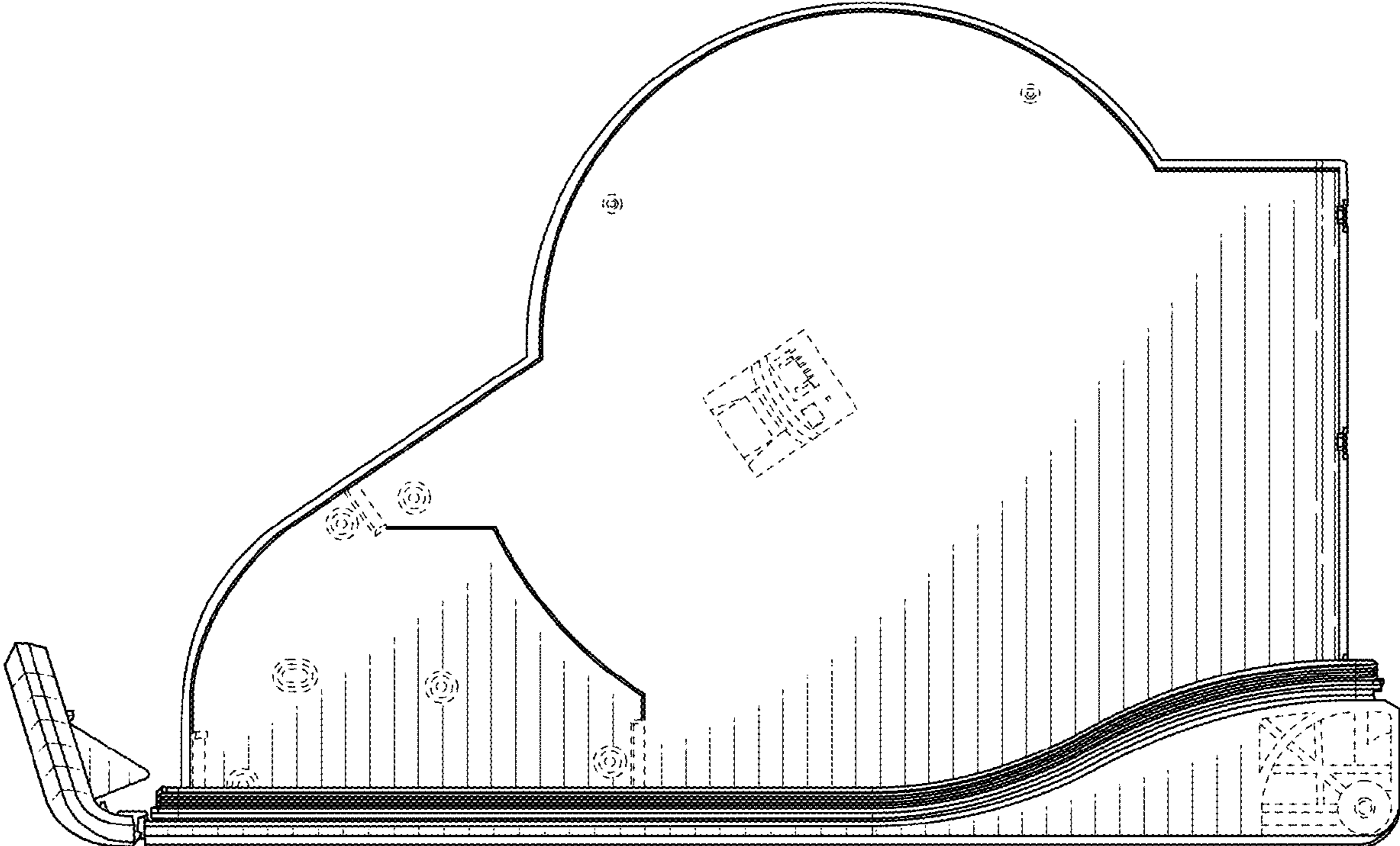

FIG. 7

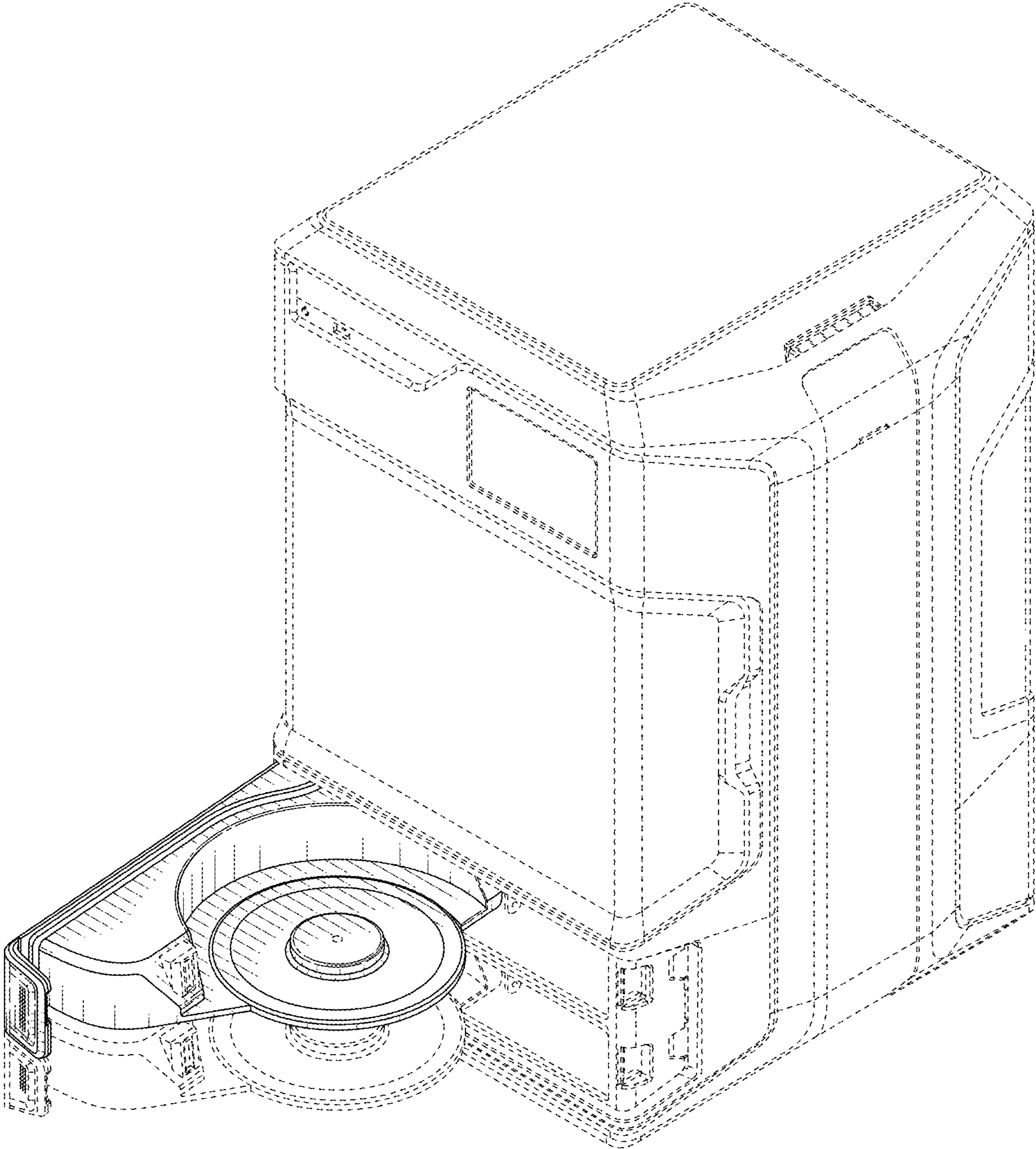

FIG. 8

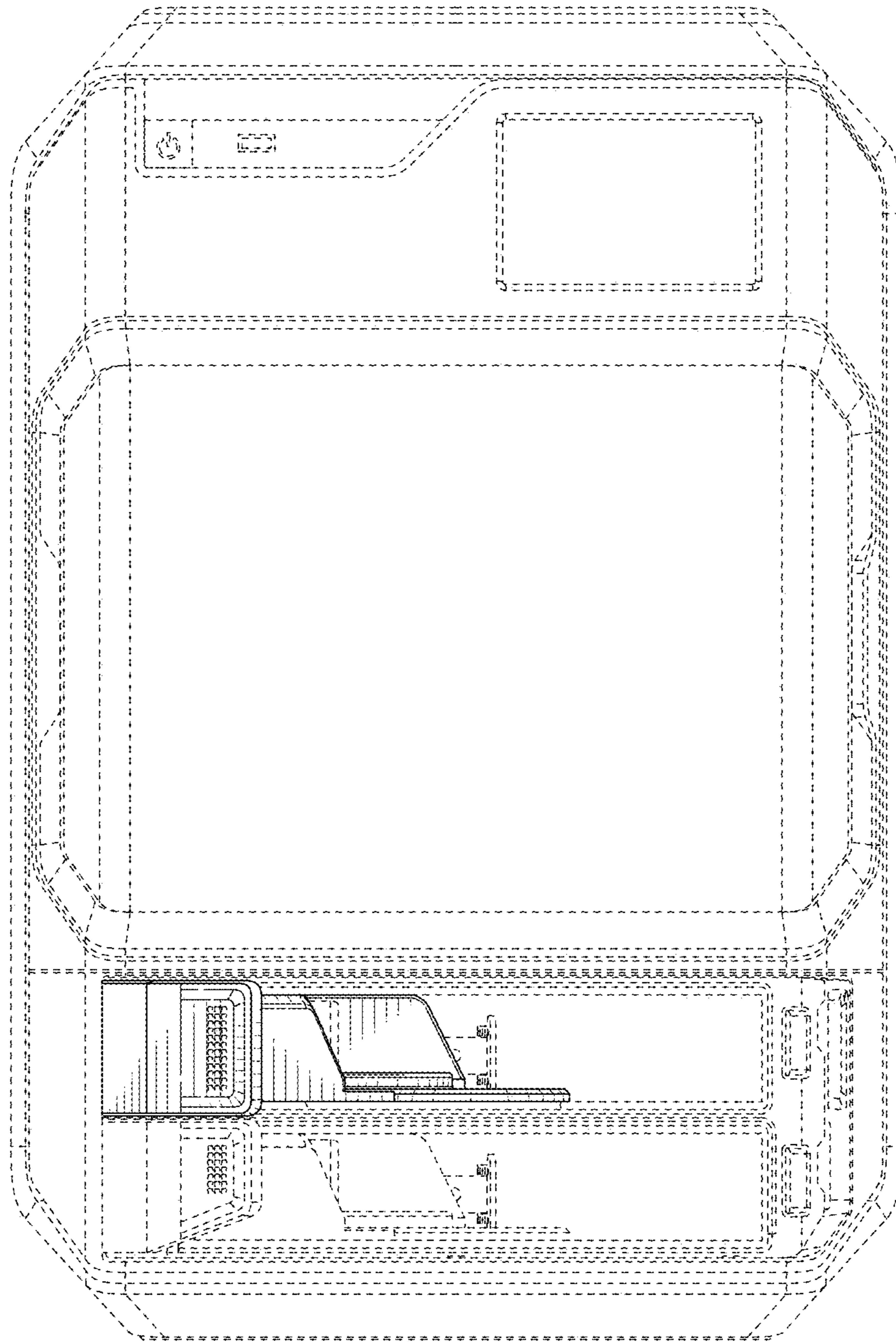

FIG. 9

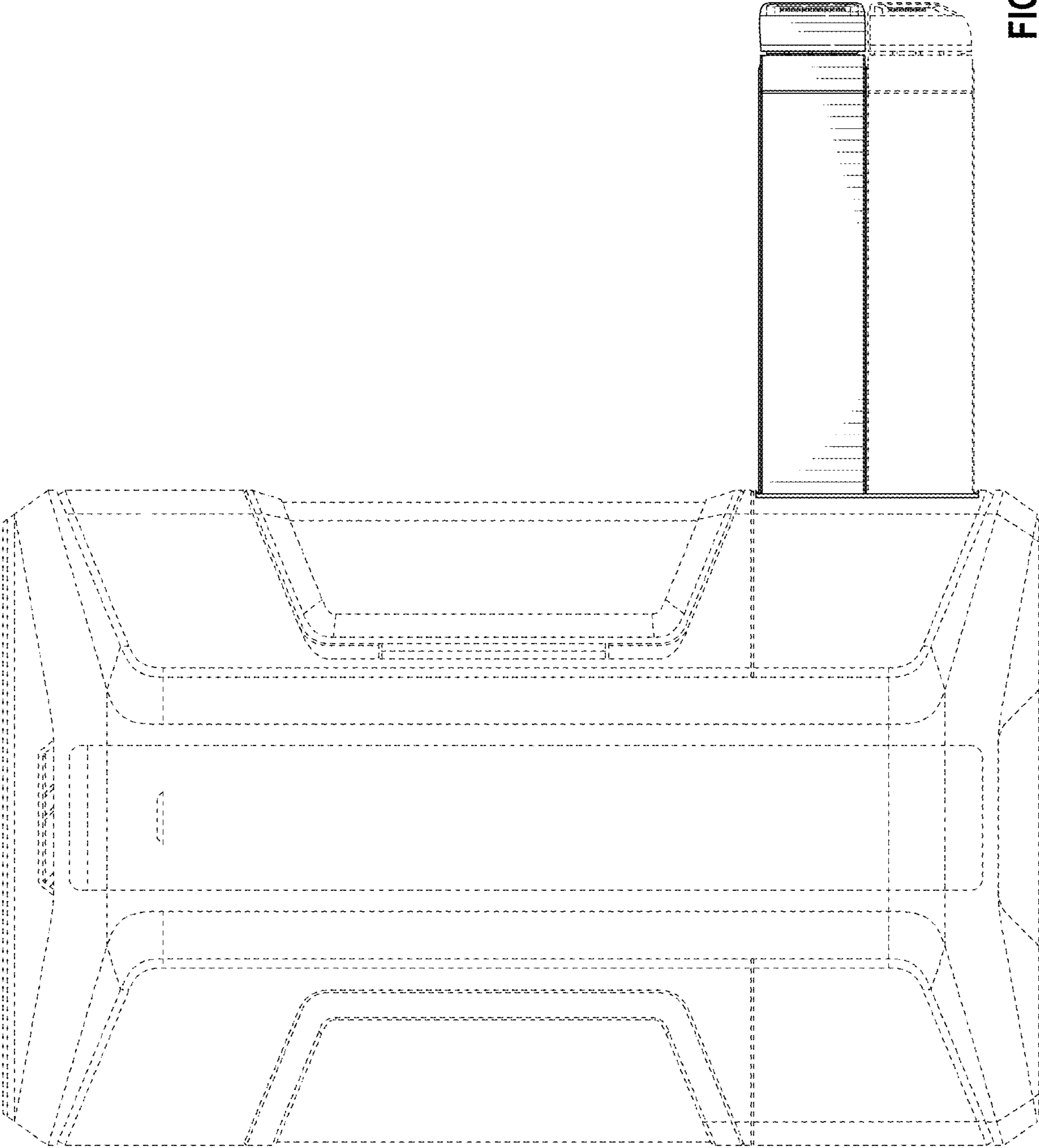

FIG. 10

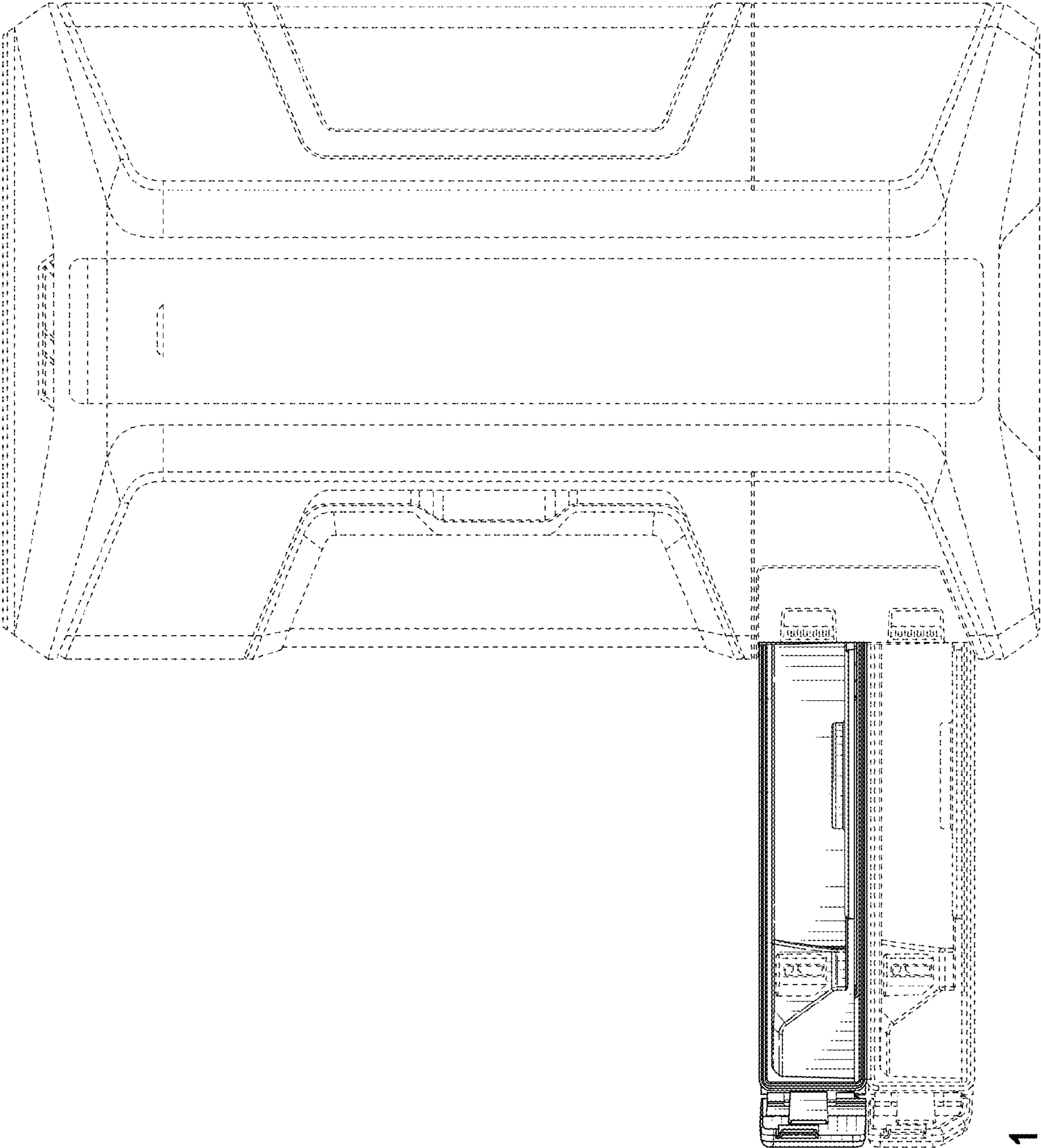

FIG. 11

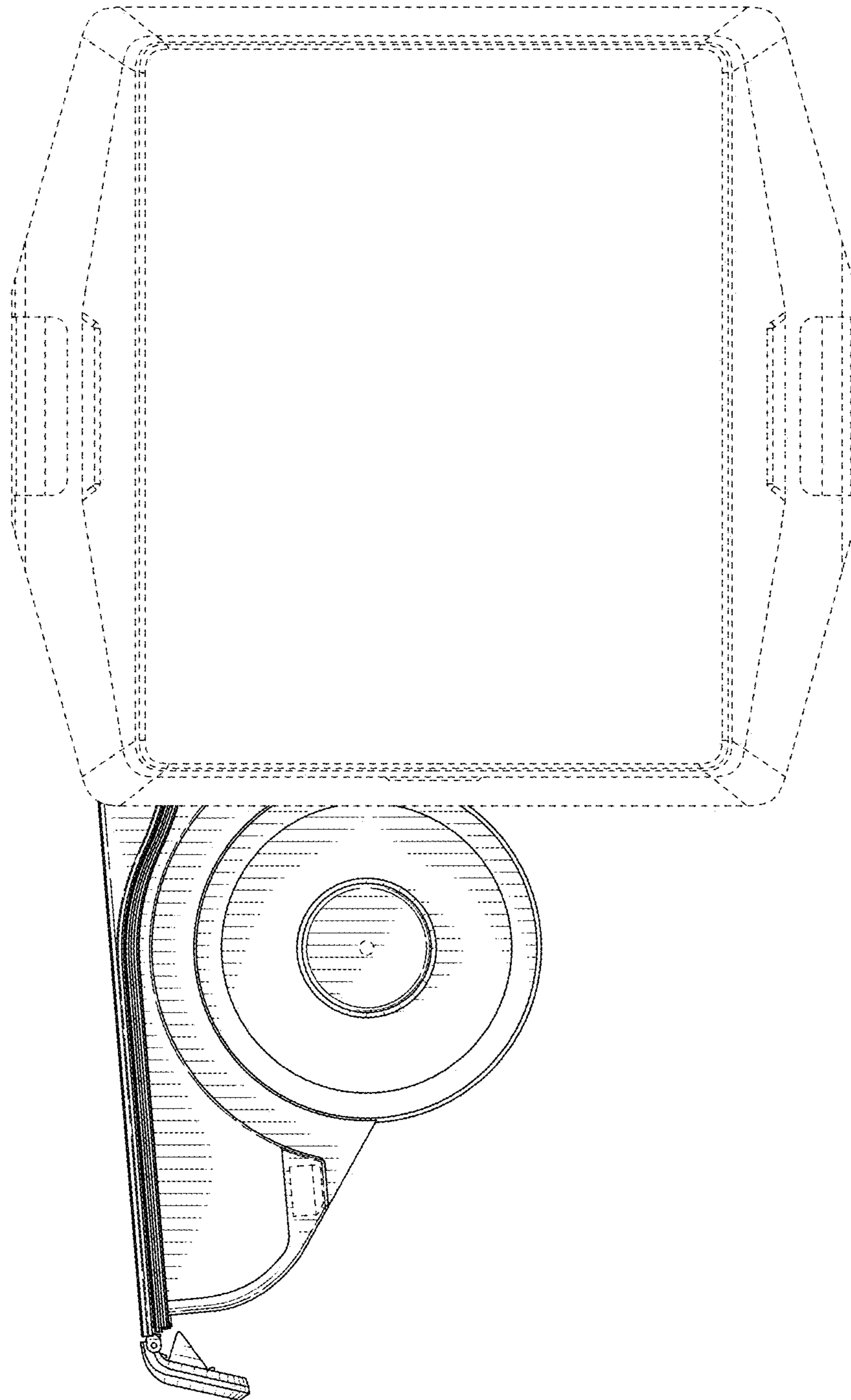

FIG. 12

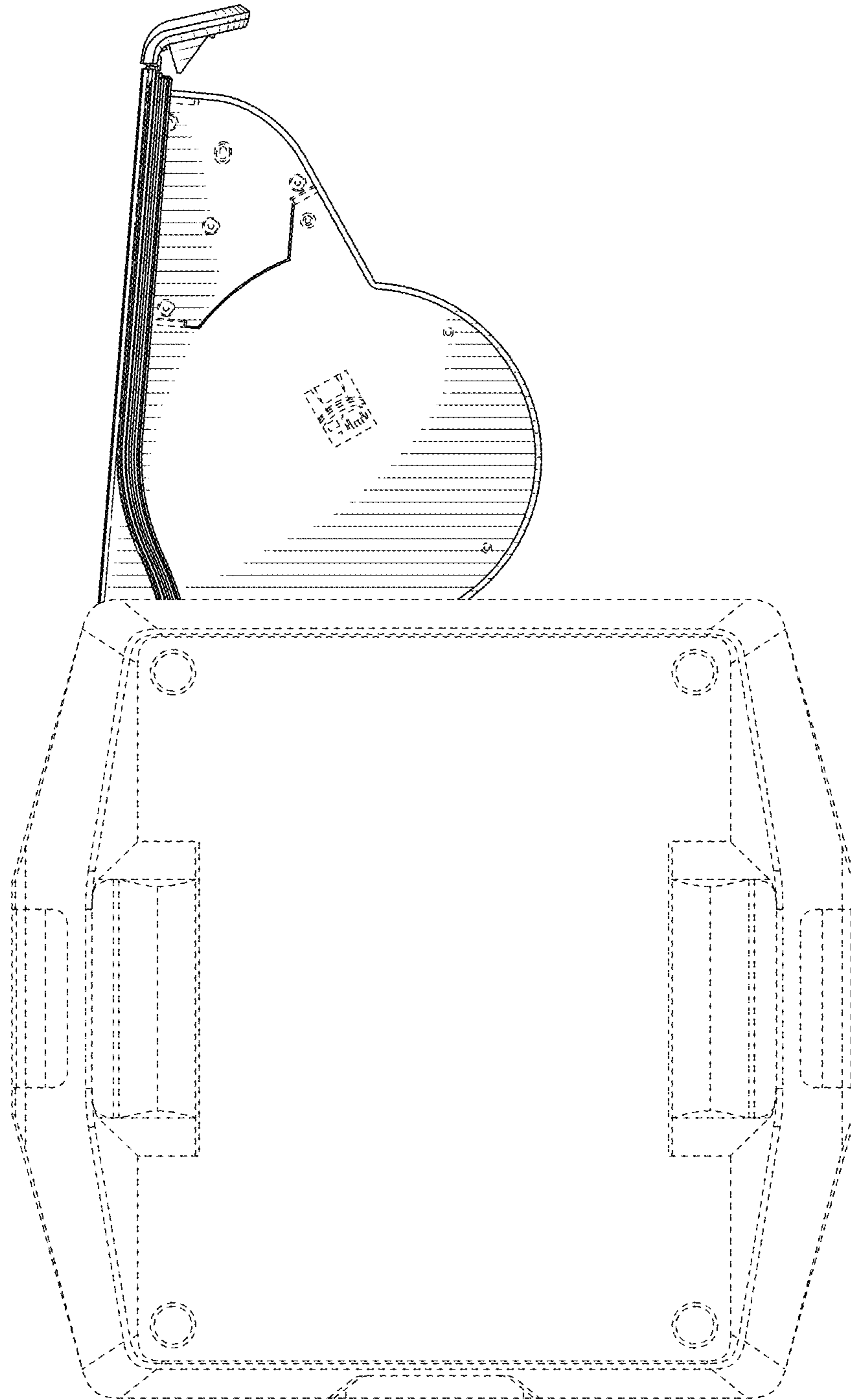

FIG. 13

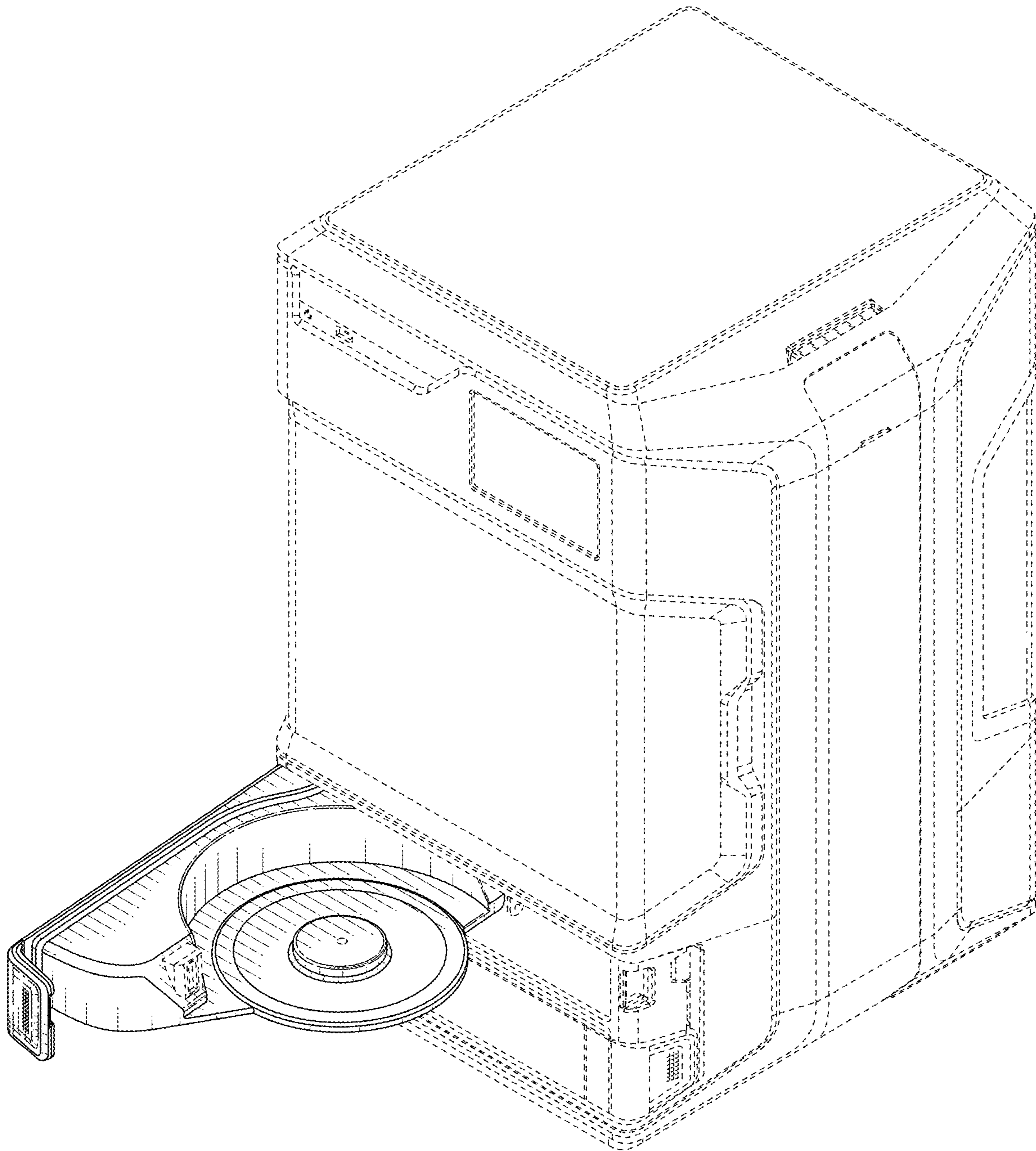

FIG. 14

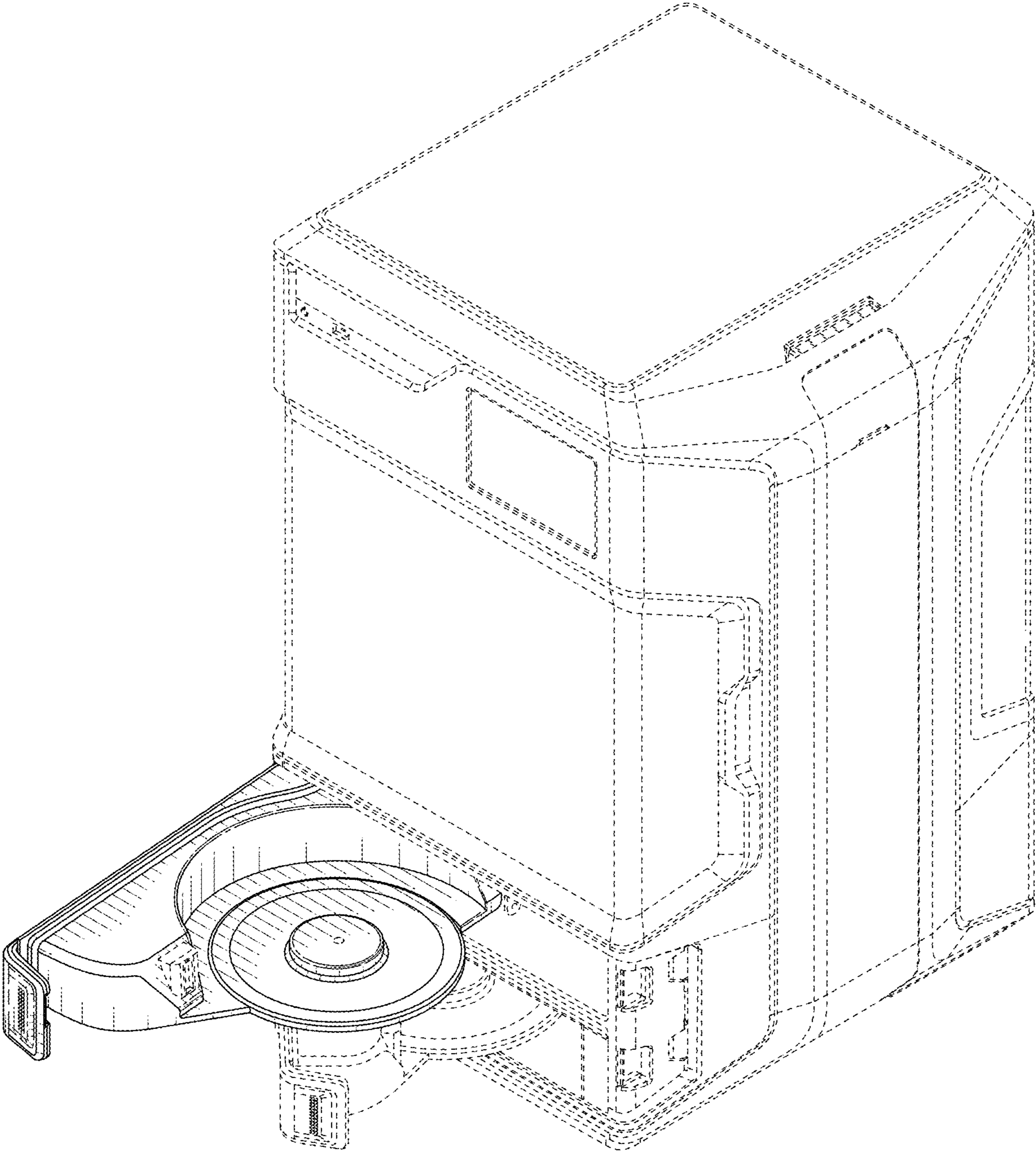

FIG. 15

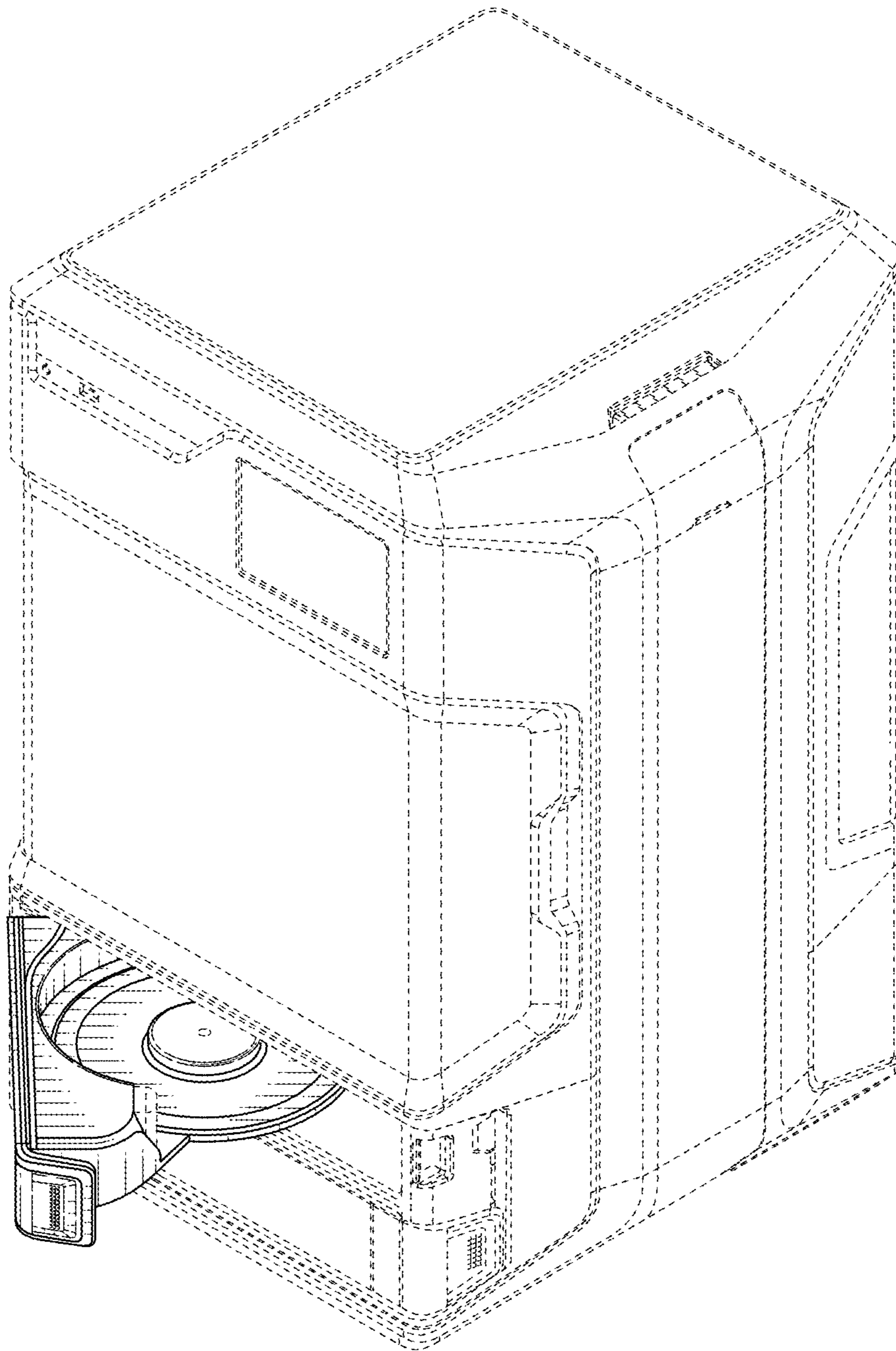

FIG. 16