



US00D899707S

(12) **United States Design Patent** (10) **Patent No.:** **US D899,707 S**
MacNeil et al. (45) **Date of Patent:** **** Oct. 20, 2020**

(54) **SINGLE-BOWL PET WATER/FOOD STATION**

D7/555, 556, 504, 565, 562, 602, 507,
D7/549, 558, 552.2, 560, 566, 548, 681;
D9/429; 43/109; D22/122; 99/430,
99/DIG. 15

(71) Applicant: **MACNEIL IP LLC**, Bolingbrook, IL
(US)

CPC A01K 5/00; A01K 5/01; A01K 5/0107;
A01K 5/0114; A01K 5/0121; A01K
5/0128; A01K 5/0135; A01K 7/005
See application file for complete search history.

(72) Inventors: **David F. MacNeil**, Fort Lauderdale, FL
(US); **Frederick W. Masanek, Jr.**,
Barrington, IL (US)

(73) Assignee: **MACNEIL IP LLC**, Bolingbrook, IL
(US)

(56) **References Cited**

U.S. PATENT DOCUMENTS

(**) Term: **15 Years**

491,702 A * 2/1893 Felix A01K 5/0135
119/61.54

(21) Appl. No.: **29/732,514**

1,135,269 A 4/1915 Dudley
D47,846 S 9/1915 Eustis
D52,657 S 11/1918 Howland
1,881,416 A 10/1932 Uhalt
D102,968 S * 1/1937 Farber D7/505
D145,192 S 7/1946 Zimmer
2,417,977 A 3/1947 French
2,560,708 A 7/1951 Titus
2,651,926 A * 9/1953 Enslein A47G 19/02
220/23.8

(22) Filed: **Apr. 24, 2020**

Related U.S. Application Data

(60) Division of application No. 29/635,541, filed on Jan.
31, 2018, which is a continuation-in-part of
application No. 29/621,052, filed on Oct. 4, 2017,
now Pat. No. Des. 887,650, which is a
continuation-in-part of application No. 29/602,916,
filed on May 4, 2017, now Pat. No. Des. 873,503,
which is a continuation-in-part of application No.
29/560,208, filed on Apr. 4, 2016, now Pat. No. Des.
802,853.

D172,715 S * 7/1954 Hogan D23/362
2,738,891 A 3/1956 Pitto
2,813,509 A 11/1957 Bruno
D183,822 S 11/1958 Barnhart
2,878,932 A 3/1959 Martire, Jr.
2,893,163 A 7/1959 Hazel, Jr.
D186,040 S 9/1959 Stageberg
2,919,456 A 1/1960 Spivey
3,019,783 A 2/1962 Clarke
3,190,486 A * 6/1965 Rech A47G 19/02
220/574

(51) **LOC (12) Cl.** **30-03**

(52) **U.S. Cl.**

USPC **D30/129; D30/133; D30/121**

(58) **Field of Classification Search**

USPC D30/133, 121, 128, 130, 132, 122, 129;
119/52.1, 55, 61.5-61.56, 51.01, 51.03,
119/59, 62, 63, 51.5, 57.8, 74, 61;
D6/480-485; 248/188, 151; 312/204;
108/153.1-157, 25-26; 220/23.87, 630,
220/737, 743, 9.4, 495.01, 574, 212, 255,
220/23.83, 575; 206/515, 557, 560, 562,
206/563, 565; D7/586, 543, 550.1, 587,
D7/505, 584, 545, 500, 553.1-553.8, 546,

3,195,510 A 7/1965 Bernstein
3,232,662 A 2/1966 Graves
D209,677 S 12/1967 Robert
D209,678 S 12/1967 Robert
3,637,454 A 1/1972 Pavernick
3,729,037 A 4/1973 Dare et al.
3,734,062 A * 5/1973 O'Hara A01K 5/0135
119/61.54

3,745,974 A 7/1973 Karasz
D229,073 S 11/1973 Brickel
3,791,550 A 2/1974 Duncan
D231,180 S * 4/1974 Vigue D7/553.4
D233,581 S 11/1974 Bridges et al.
D236,790 S 9/1975 Bruno et al.
D238,592 S 1/1976 Goldman et al.

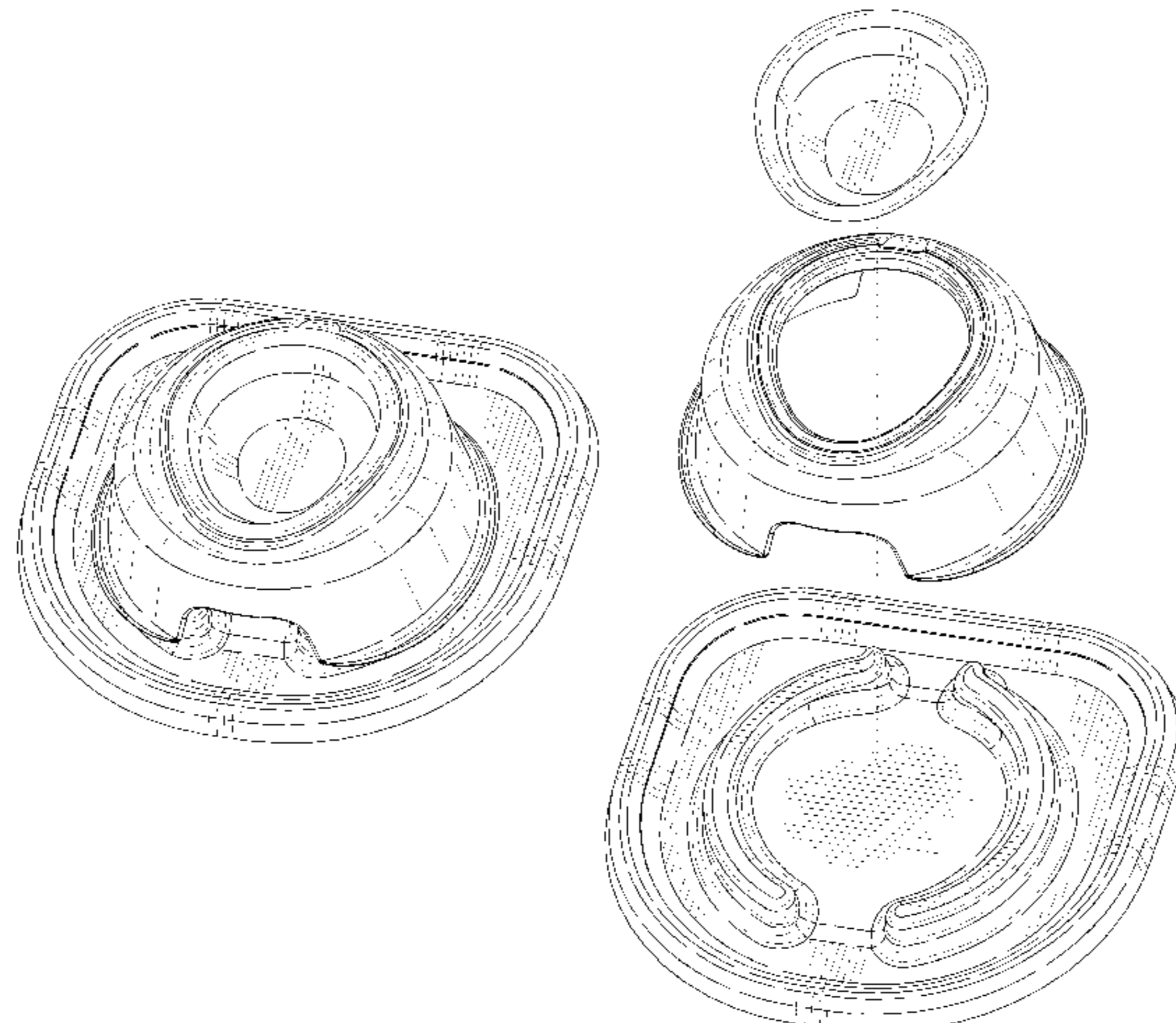

US D899,707 S

D241,917 S	10/1976	Borum		D523,186 S	6/2006	Northrop	
D242,515 S	11/1976	Shumrak et al.		D523,695 S	6/2006	Haataja	
3,995,844 A	12/1976	Hellman		D526,850 S	8/2006	Sellers et al.	
4,065,195 A	12/1977	Fahmie		D538,814 S	3/2007	Cranford et al.	
4,093,041 A	6/1978	Davis et al.		D541,486 S	4/2007	Mahaffey	
D251,652 S	4/1979	Molloy		D541,488 S	4/2007	Marsh	
D255,527 S	6/1980	Seager		D550,407 S	9/2007	Spiwak	
D259,669 S	6/1981	Peterson		D550,511 S	9/2007	Luft	
D279,067 S	6/1985	Kuster		D551,400 S	9/2007	Tsengas	
D281,481 S	11/1985	Geiser		D558,931 S	1/2008	Hood et al.	
4,576,118 A	3/1986	Meadow		D562,078 S *	2/2008	Herssein	D7/500
D285,515 S	9/1986	Papciak		7,341,019 B1	3/2008	Tsenges	
D299,010 S	12/1988	Wall		D566,363 S	4/2008	Lown et al.	
4,880,112 A	11/1989	Conrad		D573,466 S	7/2008	White et al.	
4,907,539 A	3/1990	Abulhasan		D582,265 S	12/2008	Helfman	
4,955,321 A	9/1990	Waldner		D583,111 S	12/2008	Molina-Justin	
D321,809 S	11/1991	Zobrist		7,475,937 B2	1/2009	McGrew et al.	
5,161,713 A	11/1992	English		D590,551 S *	4/2009	Sperbeck	D30/129
D335,797 S	5/1993	DeGrow		D601,310 S *	9/2009	Greenan	D30/129
D336,592 S	6/1993	DeGrow		D607,616 S	1/2010	Newsome et al.	
5,221,032 A	6/1993	Bott et al.		7,673,934 B2	3/2010	Bearup et al.	
D342,642 S	12/1993	Brazis		7,681,525 B1	3/2010	Trulove	
D348,646 S	7/1994	Reuben		D613,979 S	4/2010	Moore	
5,390,798 A	2/1995	Yanuzzi		D613,999 S	4/2010	Sierra	
D358,233 S	5/1995	Weaver		D623,358 S	9/2010	Kim	
D362,090 S	9/1995	Baldwin et al.		D623,359 S	9/2010	Kim	
D362,363 S	9/1995	Friedman		7,789,041 B1	9/2010	Taylor	
D362,389 S	9/1995	Frye		D626,791 S	11/2010	Sierra	
5,467,738 A	11/1995	Cass		7,845,845 B1 *	12/2010	Kelly	B01F 13/0818
5,493,998 A *	2/1996	Warren	A01K 5/0114				366/274
			119/61.54	D630,512 S	1/2011	Venier	
D371,644 S	7/1996	Lillelund et al.		D636,674 S	4/2011	Golota et al.	
D373,932 S	9/1996	Onneweer		D636,945 S *	4/2011	Anderson	D30/129
D374,109 S	9/1996	Lillelund et al.		D640,486 S	6/2011	Saelid	
5,560,316 A	10/1996	Lillelund et al.		D641,211 S	7/2011	Olivari et al.	
5,580,037 A	12/1996	Gore		D641,212 S	7/2011	Olivari et al.	
5,605,247 A	2/1997	Earnshaw		D641,628 S	7/2011	Baughman	
5,626,256 A	5/1997	Onneweer		D641,937 S	7/2011	Pitter	
D384,778 S	10/1997	Powers et al.		7,992,714 B1	8/2011	Devault et al.	
D386,838 S	11/1997	Pini et al.		D646,440 S	10/2011	Chance et al.	
D392,884 S	3/1998	Hayes		D646,442 S	10/2011	Chance et al.	
5,743,210 A	4/1998	Lampe		D646,852 S	10/2011	Chance et al.	
5,845,605 A *	12/1998	Malamphy	A01K 45/002	D653,000 S	1/2012	Rutherford	
			119/69.5	D655,541 S	3/2012	Zemel	
D411,709 S *	6/1999	Curtis	D7/387	8,148,651 B1	4/2012	Coppola	
D412,605 S *	8/1999	Sharon	D30/129	8,162,390 B2	4/2012	Zhong	
D413,209 S	8/1999	Jarke		D659,297 S *	5/2012	Stygstra	D30/130
D414,634 S	10/1999	Smith		D659,300 S *	5/2012	Lipscomb	D30/121
D415,657 S	10/1999	Cornelissen		D659,913 S	5/2012	Spectre et al.	
D415,933 S	11/1999	Cornelissen		8,201,879 B2	6/2012	Hartenstine et al.	
D423,292 S *	4/2000	Horvat	D7/553.6	D669,231 S	10/2012	Chance et al.	
D432,280 S	10/2000	Quinlan et al.		D670,041 S	10/2012	Chance et al.	
D433,580 S	11/2000	Jarke		D670,450 S	11/2012	Graves et al.	
D435,705 S	12/2000	Powers		D672,163 S	12/2012	Wells et al.	
6,179,377 B1	1/2001	Harper		D682,037 S *	5/2013	Cloutier	D7/554.2
D440,798 S	4/2001	Kuhlman et al.		8,516,975 B2	8/2013	Becattini, Jr. et al.	
6,209,487 B1	4/2001	Quinlan et al.		D692,623 S	10/2013	Lipscomb	
D441,441 S	5/2001	Upson		D703,393 S *	4/2014	Henley	D30/129
D442,831 S	5/2001	Jacobs		8,752,507 B2	6/2014	Korrie	
D448,978 S *	10/2001	Isbell	D7/619.1	D710,980 S	8/2014	Pollard	
D454,321 S *	3/2002	Lu	D12/203	D712,204 S	9/2014	Hatcher et al.	
6,427,626 B1	8/2002	Quinlan et al.		D716,003 S	10/2014	Brown	
D474,940 S	5/2003	Wellner		D717,104 S	11/2014	Redfern	
D477,691 S	7/2003	Crowley		D720,948 S	1/2015	Gonzalez et al.	
D487,669 S	3/2004	Smith		D722,407 S	2/2015	Roslonski et al.	
D487,823 S	3/2004	Wang		D725,836 S	3/2015	Avalos Sartorio et al.	
6,705,249 B2	3/2004	Quinlan et al.		D726,981 S *	4/2015	Yessin	D32/25
D493,672 S	8/2004	Jalet et al.		D727,576 S	4/2015	Avalos Sartorio et al.	
6,786,177 B1	9/2004	Lemkin		9,039,079 B2	5/2015	Huntsberger et al.	
D499,933 S	12/2004	Rutter et al.		9,044,077 B1	6/2015	Lin	
D504,196 S	4/2005	Huthmaker et al.		9,089,208 B2	7/2015	Zimmerman	
D504,799 S	5/2005	Lawson et al.		D735,573 S	8/2015	Jondal et al.	
6,912,970 B2	7/2005	Sage, Jr.		D737,103 S *	8/2015	Cloutier	D7/554.2
D508,822 S	8/2005	Smith et al.		9,095,117 B1	8/2015	Kumar	
D512,801 S *	12/2005	Kratzer	D30/130	9,144,321 B2	9/2015	Melo	
D517,743 S	3/2006	Perrin		D741,742 S	10/2015	Kunnas	
D521,690 S	5/2006	Krcek et al.		D742,220 S	11/2015	Eyeran et al.	
D523,185 S *	6/2006	Oliphant	A01K 5/0142	D744,174 S	11/2015	Jones et al.	
			D30/129	D745,327 S *	12/2015	Laurain	D6/614

D746,979	S	1/2016	Dominquez et al.	
9,226,478	B1	1/2016	Uhl	
D751,381	S	3/2016	Torrison et al.	
D751,382	S	3/2016	Torrison et al.	
D755,447	S *	5/2016	Andrews	D30/129
D757,373	S *	5/2016	Breit	D30/129
D758,674	S *	6/2016	Youn	D30/129
D764,206	S	8/2016	Lin	
D767,941	S	10/2016	Laurain	
D770,796	S	11/2016	Lin	
D772,701	S	11/2016	Dziaba et al.	
9,504,285	B2	11/2016	Lin	
D774,361	S	12/2016	Laurain	
D774,887	S	12/2016	Torrison et al.	
D777,992	S	1/2017	Tsengas	
9,546,033	B2 *	1/2017	Everingham	B65D 81/32
9,560,919	B2	2/2017	Terhune	
9,717,215	B2 *	8/2017	Hsu	A01K 5/0114
9,723,812	B2 *	8/2017	Jones	F16M 11/041
D797,521	S *	9/2017	Kellow, Jr.	D7/619.1
D802,368	S *	11/2017	Peng	D7/553.2
D802,853	S *	11/2017	MacNeil	D30/133
D811,666	S *	2/2018	Lopez	D30/133
D824,119	S *	7/2018	Yang	D30/130
D830,007	S *	10/2018	Harris	D30/129
D838,142	S *	1/2019	Davies	D7/553.2
10,349,623	B1 *	7/2019	Stygstra	A01K 5/00
D868,391	S *	11/2019	Townsend	D30/129
D869,781	S *	12/2019	Han	D30/130
D873,502	S *	1/2020	MacNeil	D30/130
D873,503	S *	1/2020	MacNeil	D30/133
D873,504	S *	1/2020	MacNeil	D30/133
D880,787	S *	4/2020	Price	D30/133
D880,788	S *	4/2020	Price	D30/133
D882,882	S *	4/2020	MacNeil	D30/133
D887,650	S *	6/2020	MacNeil	D30/133
2003/0106498	A1	6/2003	Mersits et al.	
2005/0039689	A1 *	2/2005	Mossmer	A01K 5/0128 119/61.5
2005/0039690	A1	2/2005	Sage, Jr.	
2005/0045113	A1	3/2005	Wetterer et al.	
2005/0115508	A1	6/2005	Little	
2005/0235919	A1	10/2005	Willinger et al.	
2006/0096544	A1	5/2006	Spiwak	
2007/0264450	A1	11/2007	White et al.	
2008/0245947	A1 *	10/2008	Webb	A47G 19/10 248/683
2009/0199775	A1	8/2009	Shamoon	
2009/0241844	A1	10/2009	Becattini, Jr. et al.	
2010/0107984	A1	5/2010	Uffner et al.	
2010/0162961	A1	7/2010	Hove et al.	
2010/0180827	A1	7/2010	Becattini, Jr. et al.	
2011/0253054	A1	10/2011	Hargrove	
2012/0186497	A1	7/2012	Spano	
2013/0118412	A1	5/2013	Korrie	
2013/0334377	A1	12/2013	Lee	
2014/0261203	A1	9/2014	Renforth et al.	
2014/0338573	A1	11/2014	Rassat	
2014/0346293	A1	11/2014	Qui	
2015/0101543	A1 *	4/2015	Baxter	A01K 5/0142 119/498
2015/0214090	A1	7/2015	Jin et al.	
2016/0037744	A1	2/2016	Rudin	
2016/0120147	A1	5/2016	Antonio	
2016/0219832	A1 *	8/2016	Langston	A01K 5/0142
2017/0071155	A1	3/2017	Gailen	
2017/0086423	A1	3/2017	Wall	
2017/0280675	A1 *	10/2017	MacNeil	A01K 7/005
2018/0014505	A1 *	1/2018	MacNeil	A01K 7/005
2018/0020637	A1 *	1/2018	MacNeil	A01K 5/0135 119/61.54
2018/0199542	A1 *	7/2018	Foster	A01K 5/0135
2018/0242553	A1 *	8/2018	Nemeth	B65D 25/04
2018/0368594	A1 *	12/2018	Hakim	F16B 47/00

FOREIGN PATENT DOCUMENTS

JP D1232810 3/2005

OTHER PUBLICATIONS

International Searching Authority, Written Opinion, dated Aug. 17, 2017, seven pages.
 Doctor's Advice Peppy, Pet Feeding Systems, catalog, Aug. 31, 2002, vol. 20, Japan.
 Benesse Corporation, Pet Feeding Station, web page, downloaded prior to Jan. 31, 2018, Japan.
 amazon.com, Collapsible Pet Feeder—small, pink, web page, downloaded prior to Jan. 31, 2018, Japan.
 T-K-Maxx, Pink Flexi Pet Bowl Duo, web page, downloaded prior to Jan. 31, 2018, Japan.
 Iris Ohyama Incorporated, Pet Feeding Bowls, web page, Jul. 2, 2007.
 amazon.com, Double Bowl Feeding Station by Pupmoms, web page, Jan. 10, 2018.
 National Center for Industrial Property Information and Training, house.richell.co.jp, Oblong Bowls, downloaded Jan. 10, 2018.
 Nissen Company Limited, Oblong Bowl, web page, downloaded prior to Jan. 31, 2018, Japan.
 National Center for Industrial Property Information and Training, www.e-narumi.com, Oblong Bowl, downloaded Jan. 10, 2018.

* cited by examiner

Primary Examiner — Susan Moon Lee
 (74) *Attorney, Agent, or Firm* — Perkins IP Law Group LLC; Jefferson Perkins

(57) CLAIM

We claim the ornamental design for a single-bowl pet water/food station, as shown and described.

DESCRIPTION

FIG. 1 is a top perspective view of a single-bowl pet water/food station in accordance with our design;
 FIG. 2 is a top perspective extended view of the embodiment shown in FIG. 1;
 FIG. 3 is a bottom perspective extended view of the embodiment shown in FIG. 1;
 FIG. 4 is a top view of the embodiment shown in FIG. 1;
 FIG. 5 is a front view of the embodiment shown in FIG. 1;
 FIG. 6 is a rear view of the embodiment shown in FIG. 1;
 FIG. 7 is a left side view of the embodiment shown in FIG. 1, a right side view thereof being a mirror image of the left side view;
 FIG. 8 is a top perspective view of a stand used in the embodiment shown in FIG. 1;
 FIG. 9 is a top view of the stand shown in FIG. 8;
 FIG. 10 is a front view of the stand shown in FIG. 8;
 FIG. 11 is a rear view of the stand shown in FIG. 8;
 FIG. 12 is a right side view of the stand shown in FIG. 8, a left side view thereof being a mirror image of the right side view;
 FIG. 13 is a sectional view taken along Line 13-13 of FIG. 9;
 FIG. 14 is a sectional view taken along Line 14-14 of FIG. 9;
 FIG. 15 is a top perspective view of a mat used in the embodiment shown in FIG. 1;
 FIG. 16 is a top view of the mat shown in FIG. 15;
 FIG. 17 is a front view of the mat shown in FIG. 15;
 FIG. 18 is a rear view of mat shown in FIG. 15;
 FIG. 19 is a left side view of the mat shown in FIG. 15, a right side view thereof being a mirror image of the left side view;

FIG. 20 is a sectional view taken along Line 20-20 of FIG. 16;
FIG. 21 is a sectional view taken along Line 21-21 of FIG. 16;
FIG. 22 is a top perspective view of a second embodiment of our design;
FIG. 23 is a top perspective extended view of the embodiment shown in FIG. 22;
FIG. 24 is a bottom perspective extended view of the embodiment shown in FIG. 22;
FIG. 25 is a top view of the embodiment shown in FIG. 22;
FIG. 26 is a front view of the embodiment shown in FIG. 22;
FIG. 27 is a rear view of the embodiment shown in FIG. 22;
FIG. 28 is a left side view of the embodiment shown in FIG. 22, a right side view thereof being a mirror image of the left side view;
FIG. 29 is a top perspective view of a stand used in the embodiment shown in FIG. 22;
FIG. 30 is a top view of the stand shown in FIG. 29;
FIG. 31 is a front view of the stand shown in FIG. 29;
FIG. 32 is a rear view of the stand shown in FIG. 29;
FIG. 33 is a right side view of the stand shown in FIG. 29, a left side view thereof being a mirror image of the right side view;
FIG. 34 is a sectional view taken along Line 34-34 of FIG. 30;
FIG. 35 is a sectional view taken along Line 35-35 of FIG. 30;
FIG. 36 is a top perspective view of a mat used in the embodiment shown in FIG. 22;
FIG. 37 is a top view of the mat shown in FIG. 36;
FIG. 38 is a front view of the mat shown in FIG. 36;
FIG. 39 is a rear view of the mat shown in FIG. 36;
FIG. 40 is a left side view of the mat shown in FIG. 36, a right side view thereof being a mirror image of the left side view;
FIG. 41 is a sectional view taken along Line 41-41 of FIG. 37;
FIG. 42 is a sectional view taken along Line 42-42 of FIG. 37;
FIG. 43 is a top perspective view of a third embodiment of our design;

FIG. 44 is a top perspective extended view of the embodiment shown in FIG. 43;
FIG. 45 is a bottom perspective extended view of the embodiment shown in FIG. 43;
FIG. 46 is a top view of the embodiment shown in FIG. 43;
FIG. 47 is a front view of the embodiment shown in FIG. 43;
FIG. 48 is a rear view of the embodiment shown in FIG. 43;
FIG. 49 is a left side view of the embodiment shown in FIG. 43, a right side view thereof being a minor image of the left side view;
FIG. 50 is a top perspective view of a stand used in the embodiment shown in FIG. 43;
FIG. 51 is a top view of the stand shown in FIG. 50;
FIG. 52 is a front view of the stand shown in FIG. 50;
FIG. 53 is a rear view of the stand shown in FIG. 50;
FIG. 54 is a right side view of the stand shown in FIG. 50, a left side view thereof being a mirror image of the right side view;
FIG. 55 is a sectional view taken along Line 55-55 of FIG. 51;
FIG. 56 is a sectional view taken along Line 56-56 of FIG. 51;
FIG. 57 is a top perspective view of a mat used in the embodiment shown in FIG. 43;
FIG. 58 is a top view of the mat shown in FIG. 57;
FIG. 59 is a front view of the mat shown in FIG. 57;
FIG. 60 is a rear view of the mat shown in FIG. 57;
FIG. 61 is a left side view of the mat shown in FIG. 57, a right side view thereof being a minor image of the left side view;
FIG. 62 is a sectional view taken along Line 62-62 of FIG. 58; and,
FIG. 63 is a sectional view taken along Line 63-63 of FIG. 58.
The bottoms of the assembled stations shown in FIGS. 1-7, 22-28 and 43-49, the bottoms of the stands shown in FIGS. 8-14, 29-35 and 50-56, and the bottoms of the mats shown in FIGS. 15-21, 36-42 and 57-63 are unadorned and form no portion of the claimed design. The broken line showing of the environment is for illustrative purposes only and forms no part of the claimed design.

1 Claim, 36 Drawing Sheets

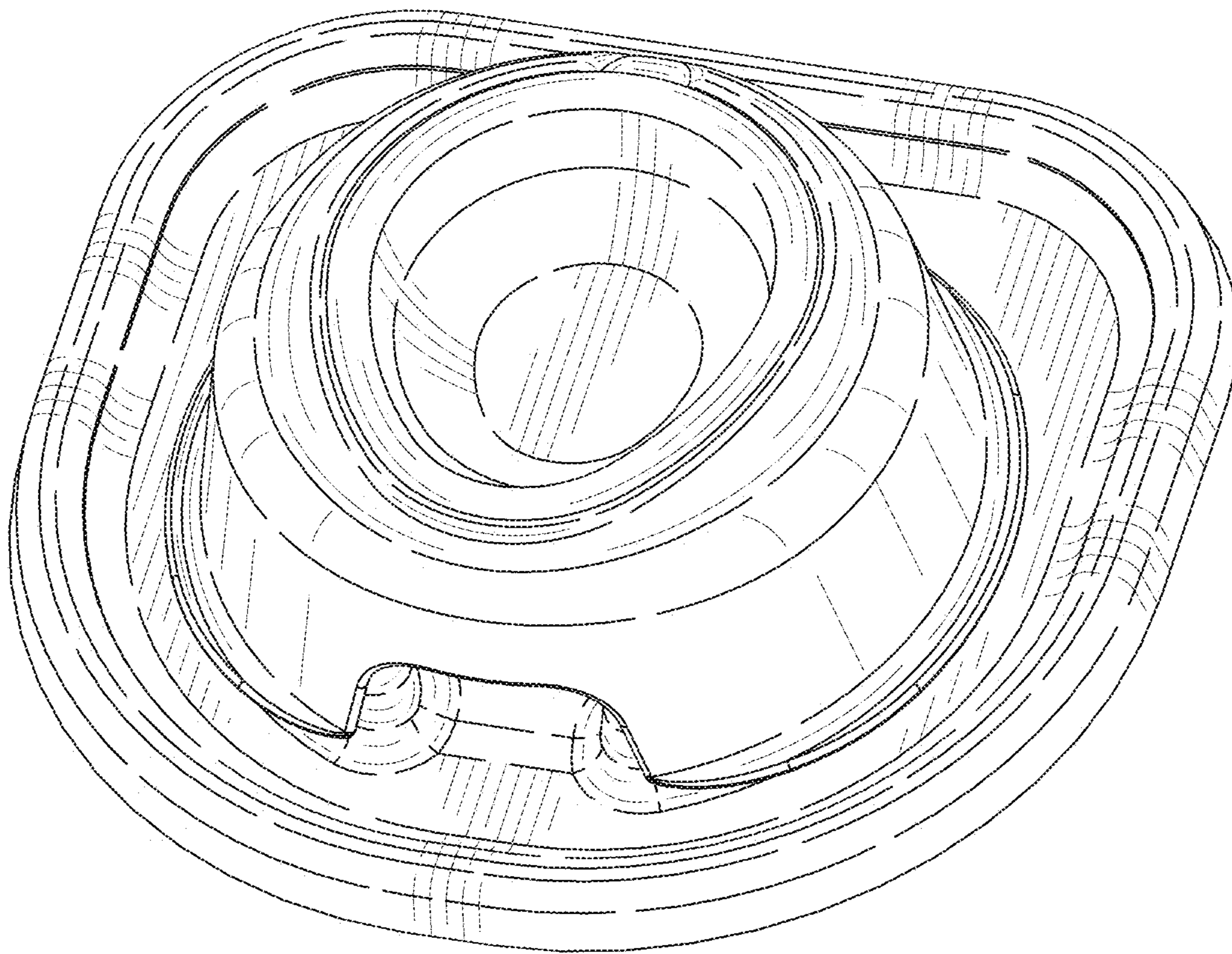

FIG. 1

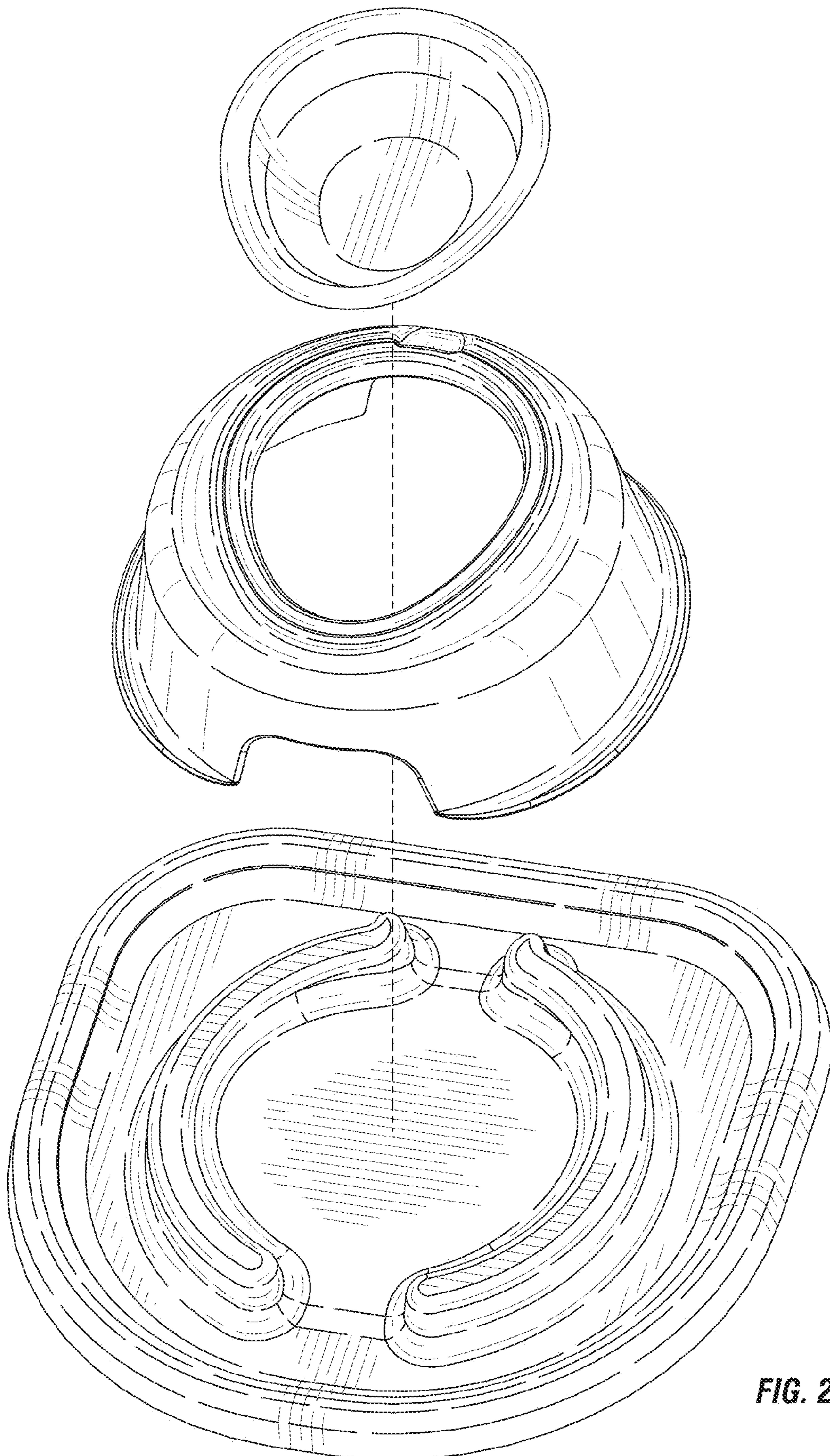

FIG. 2

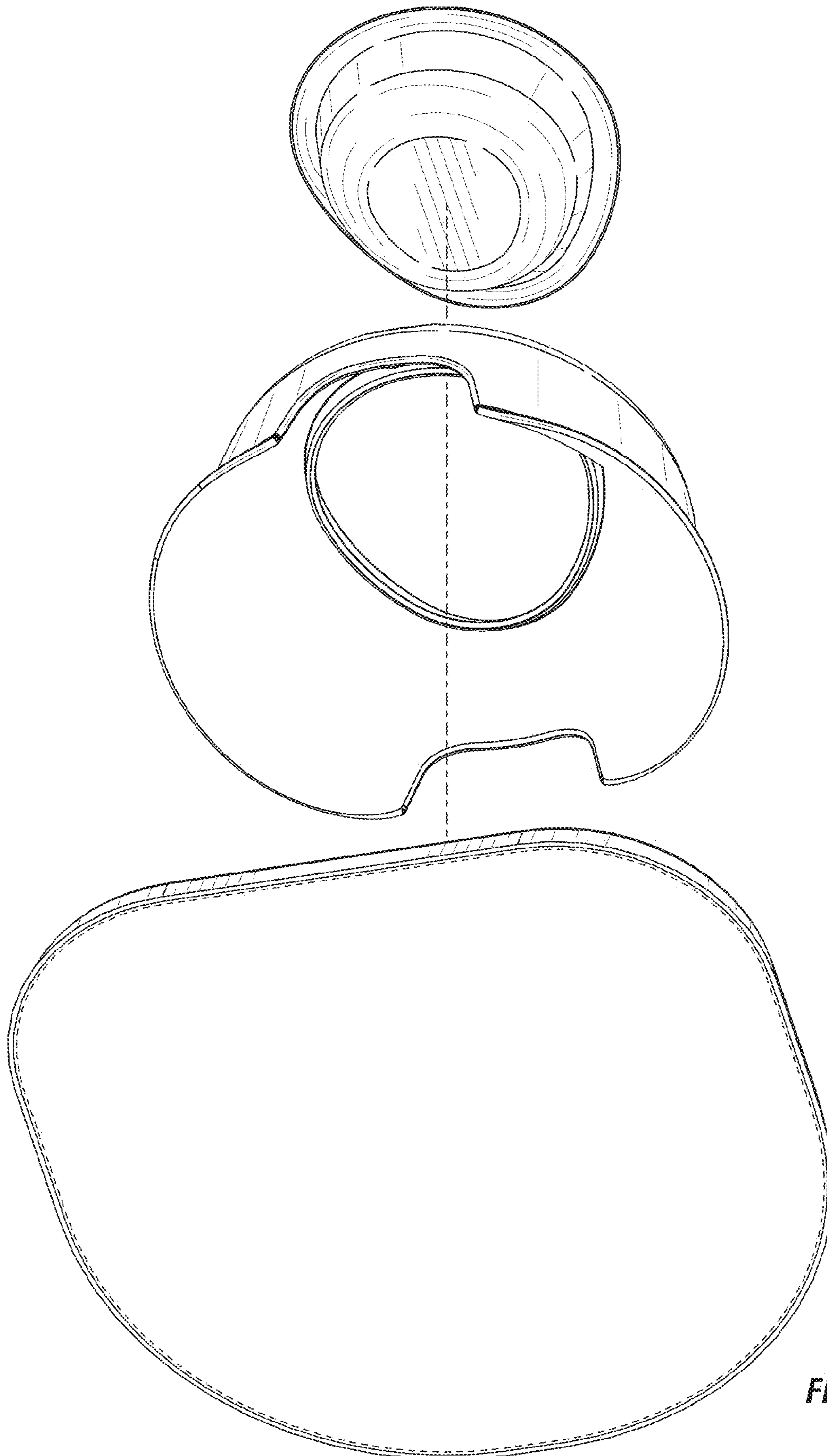

FIG. 3

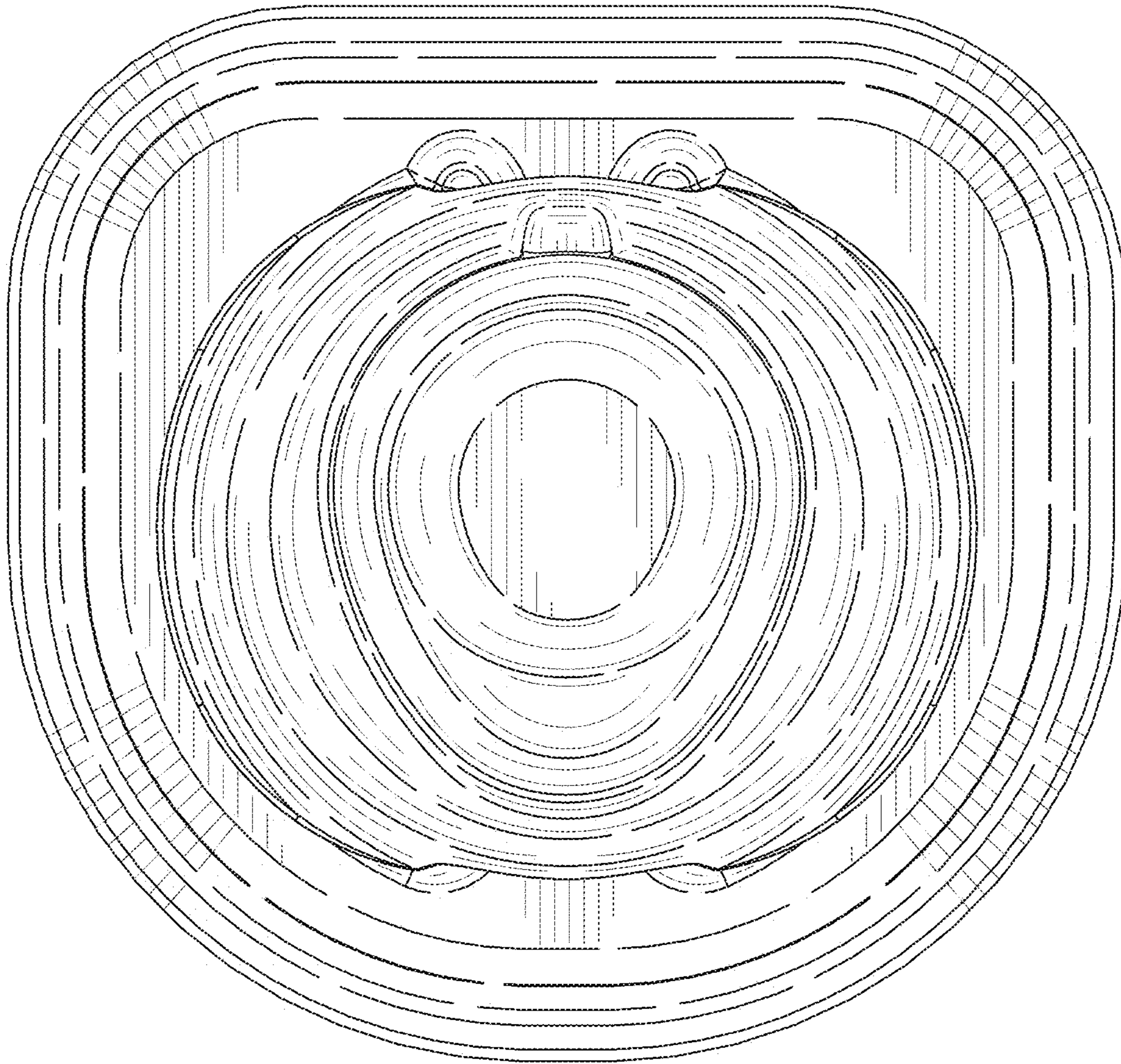

FIG. 4

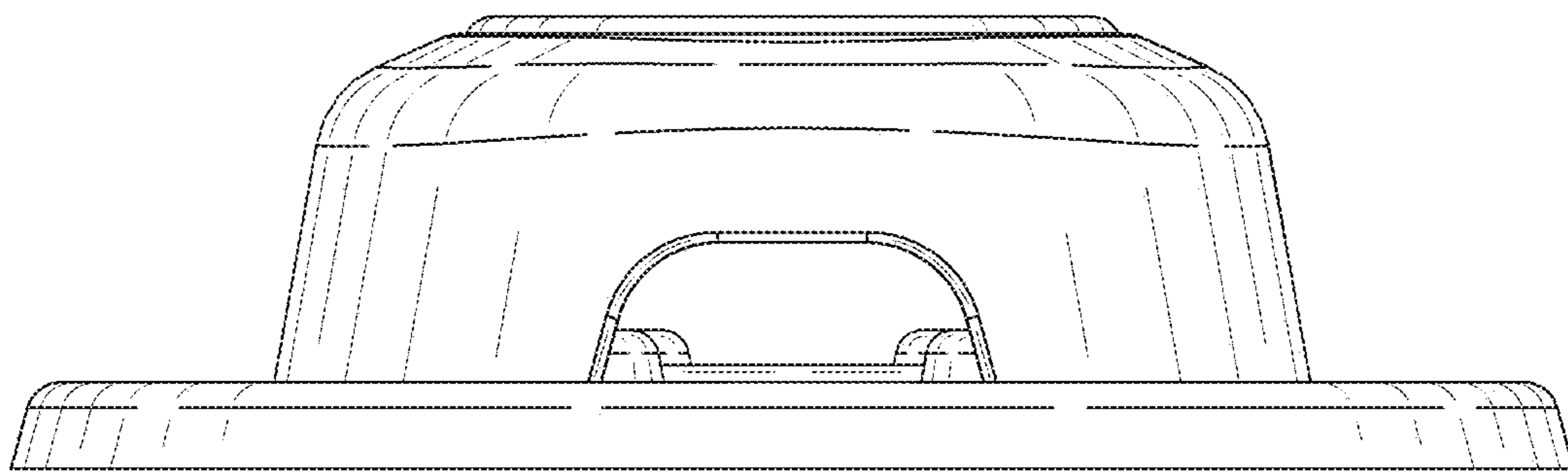

FIG. 5

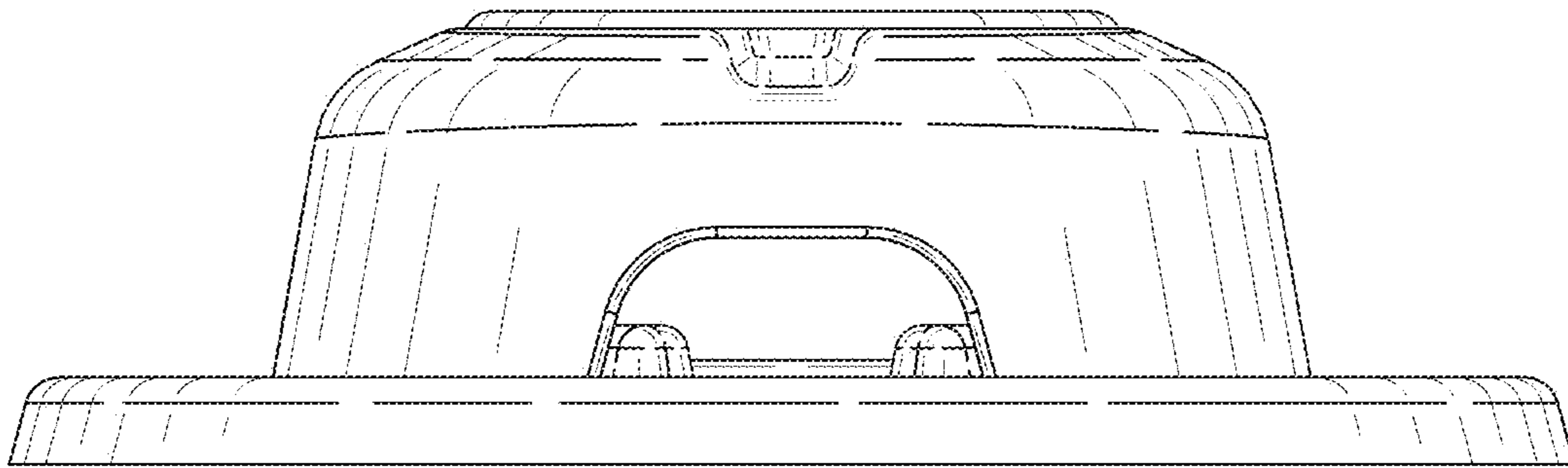

FIG. 6

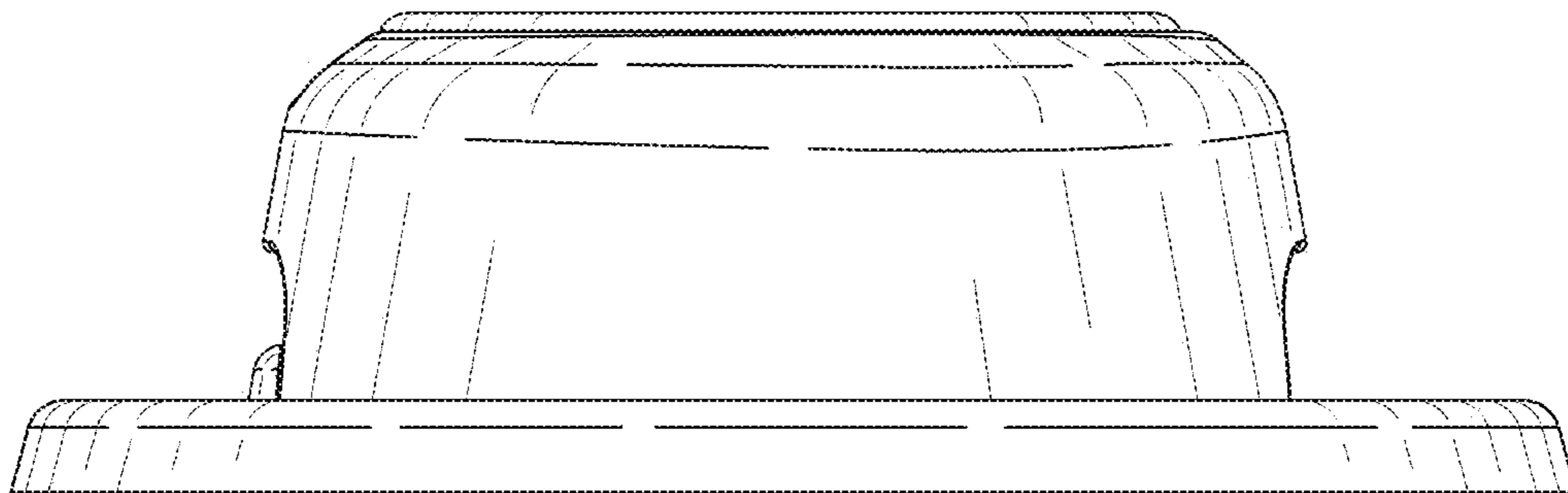

FIG. 7

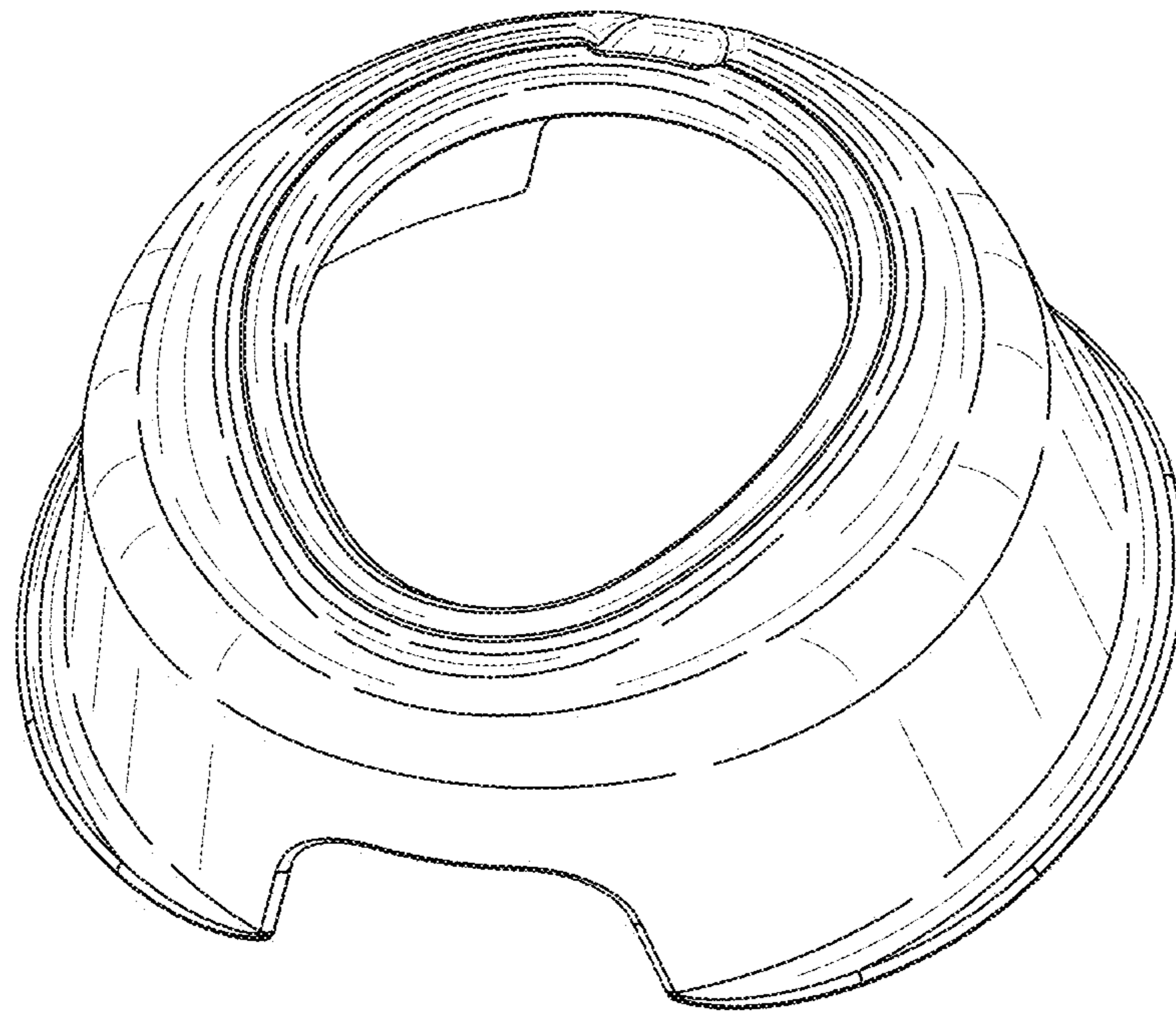

FIG. 8

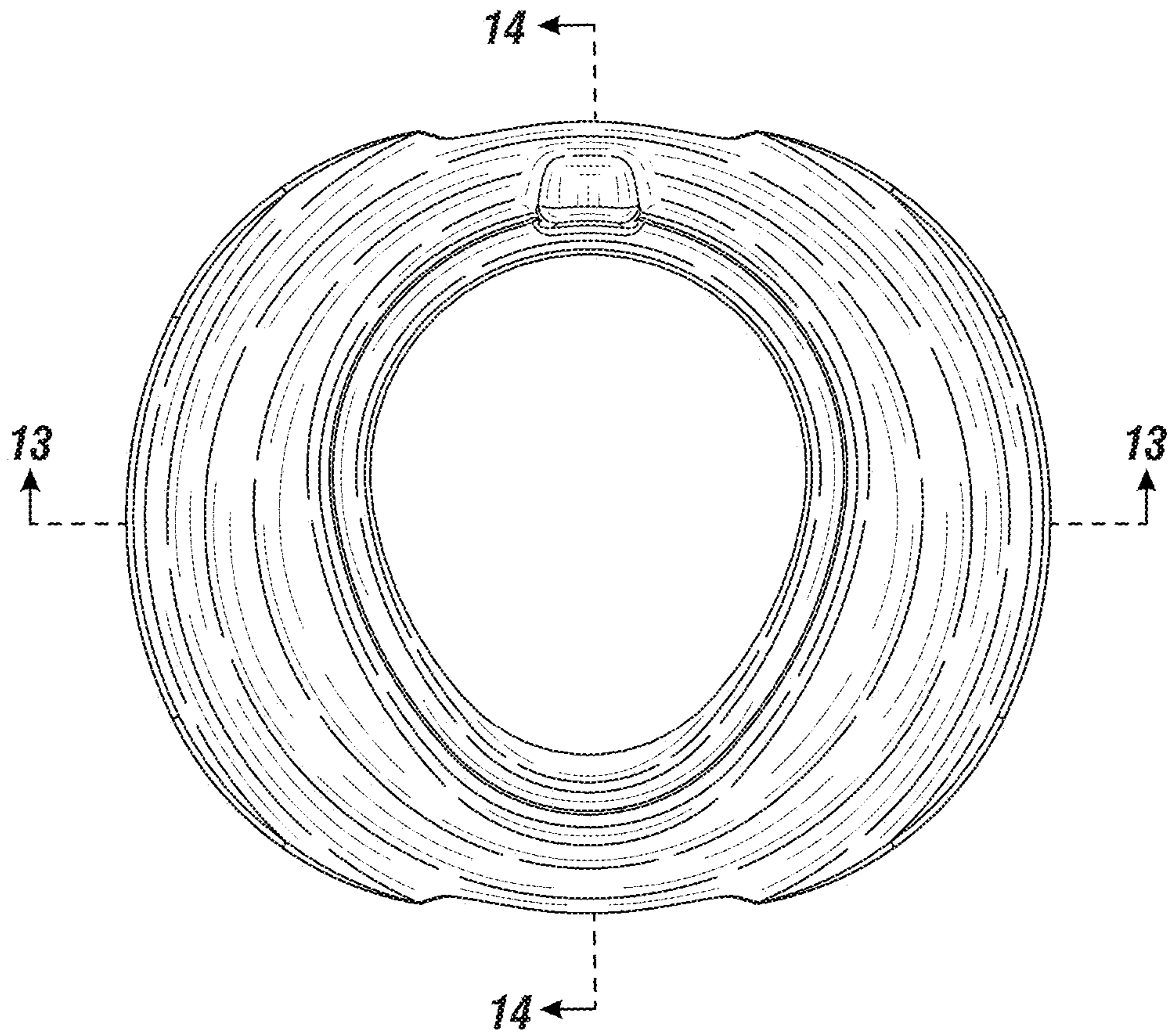

FIG. 9

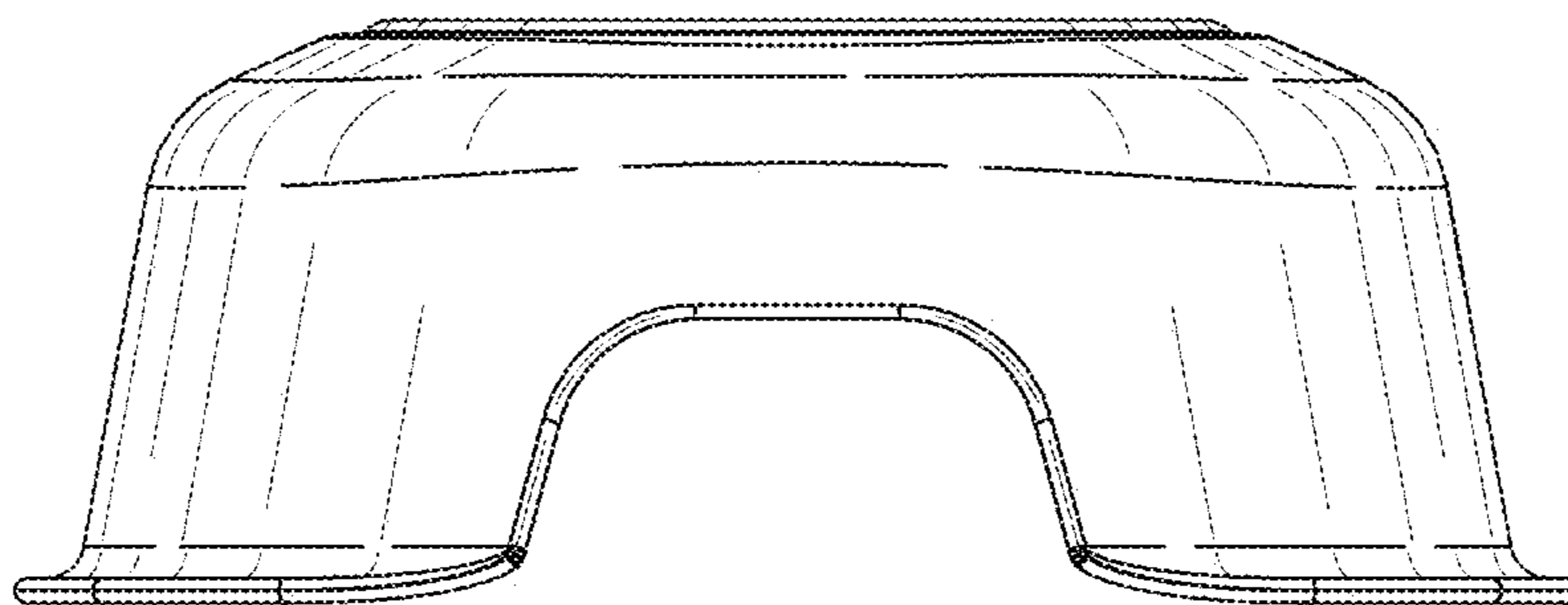

FIG. 10

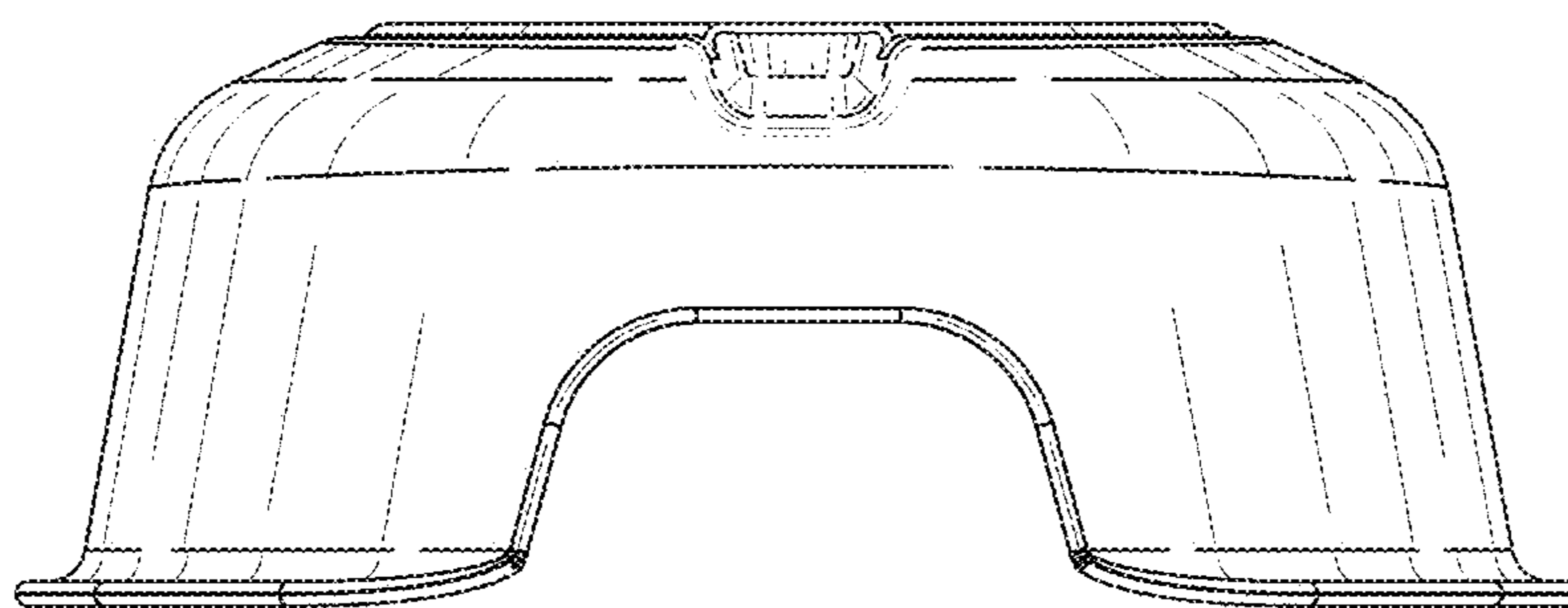

FIG. 11

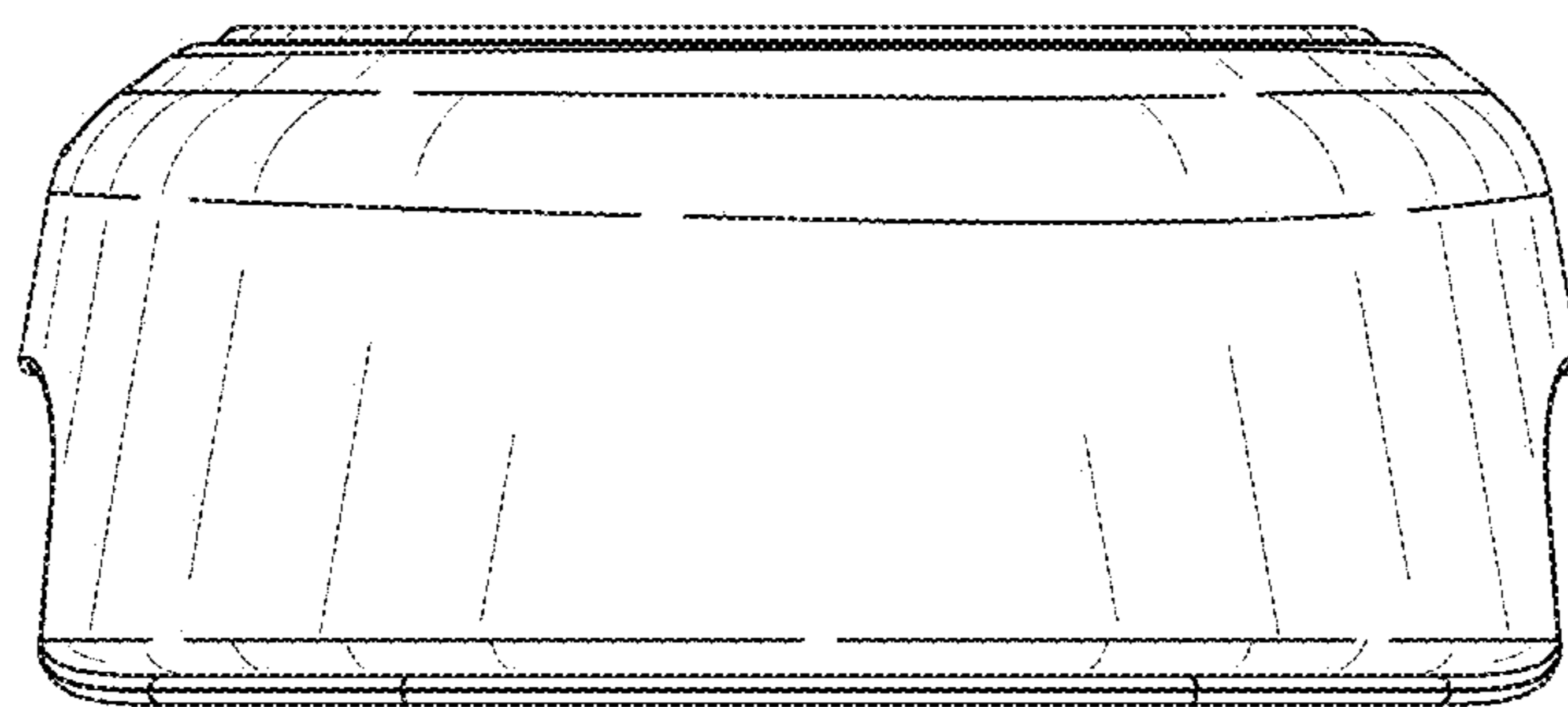

FIG. 12

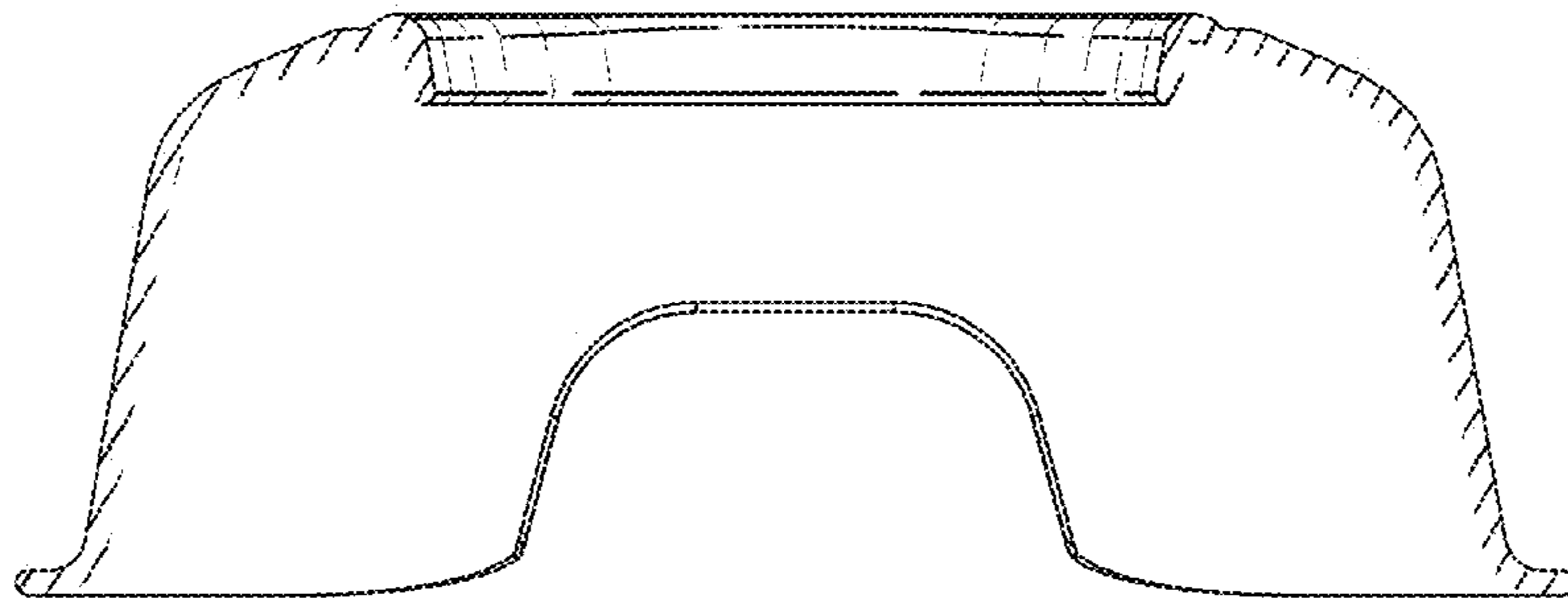

FIG. 13

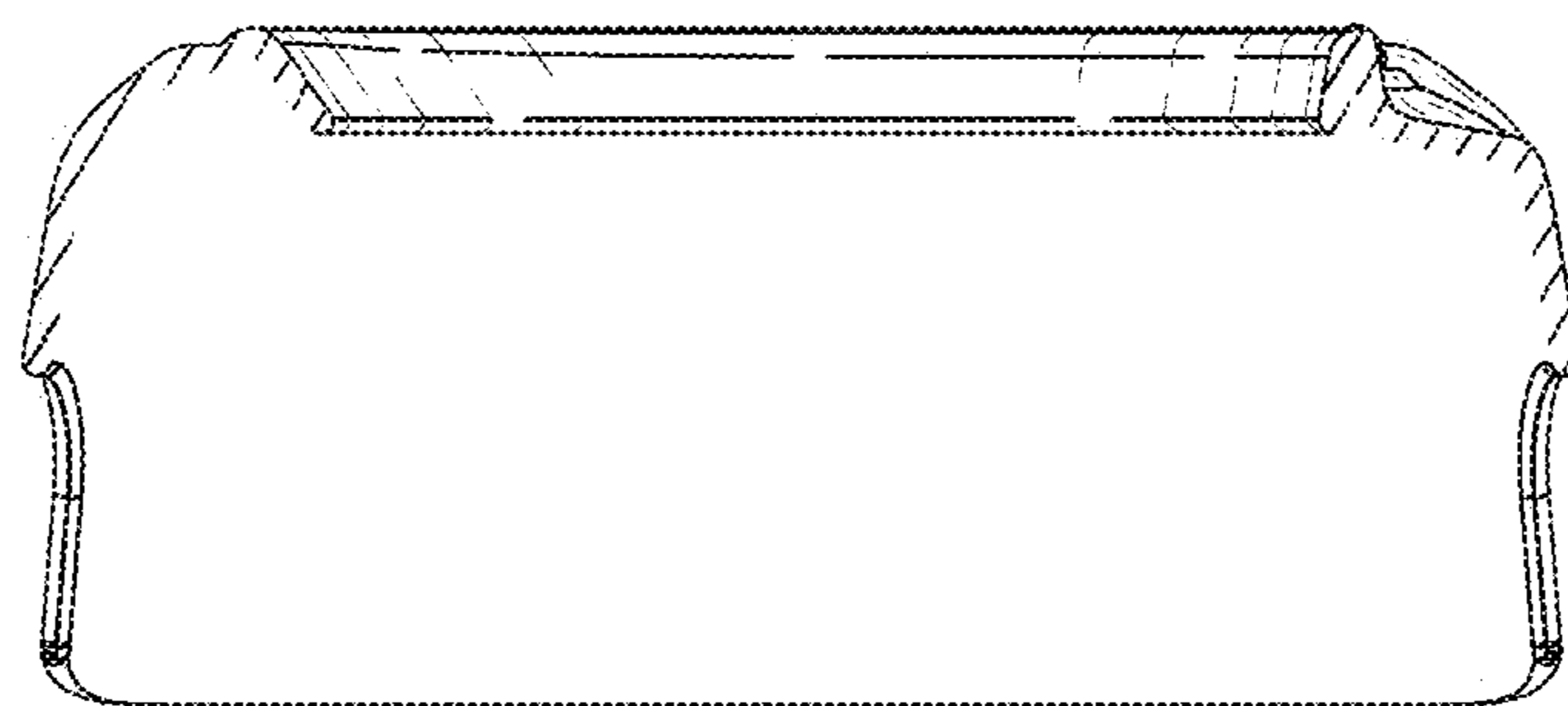

FIG. 14

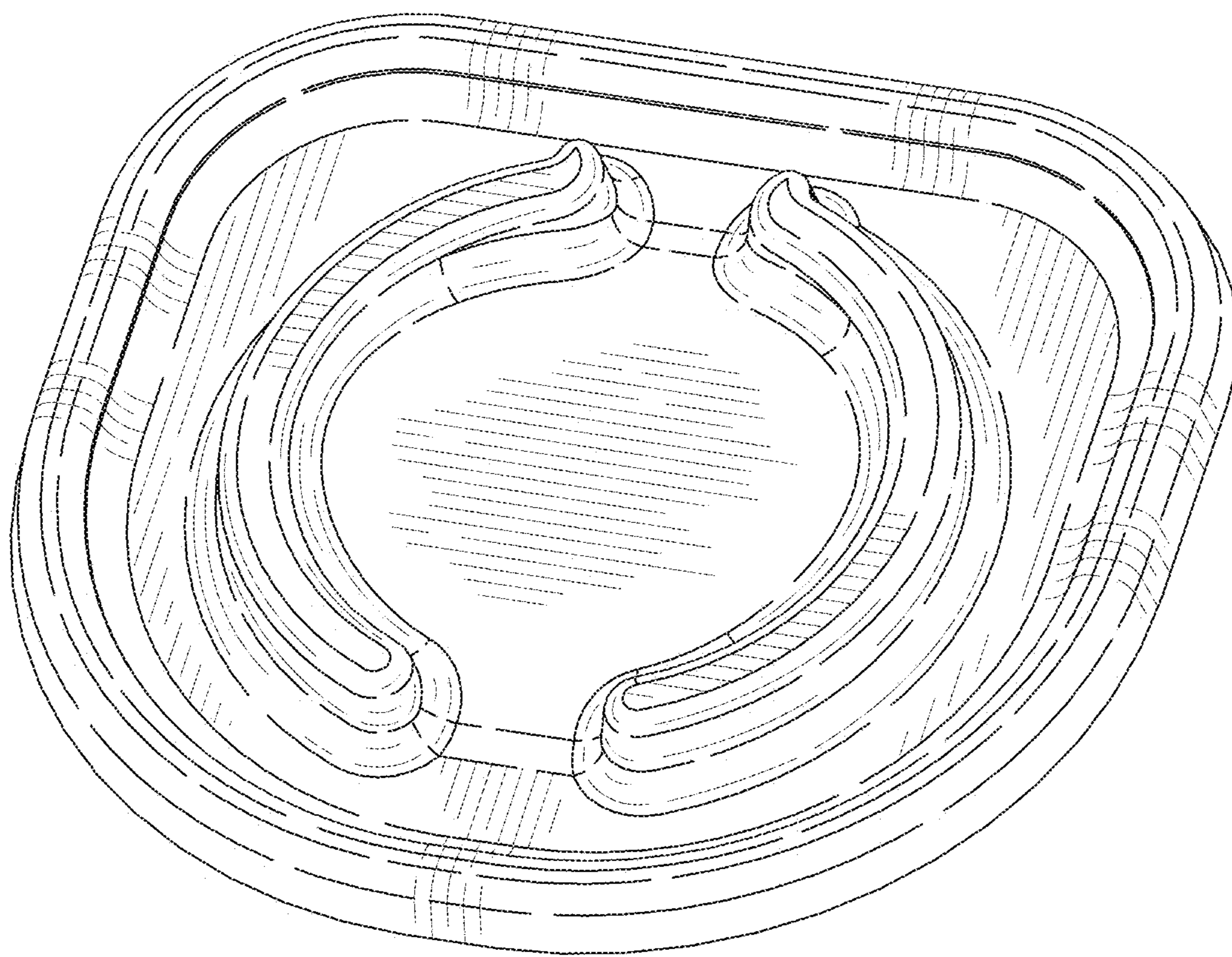

FIG. 15

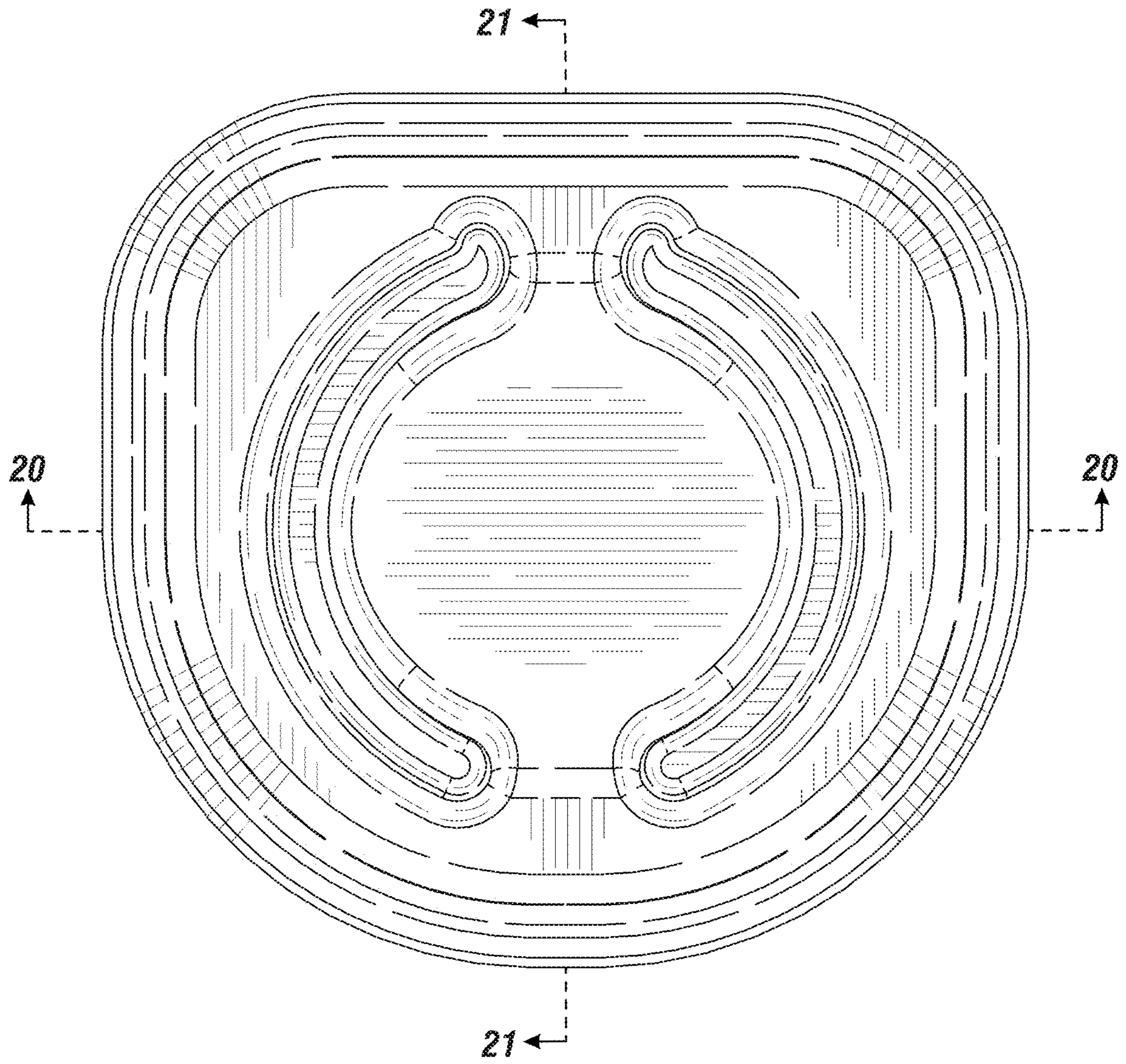

FIG. 16

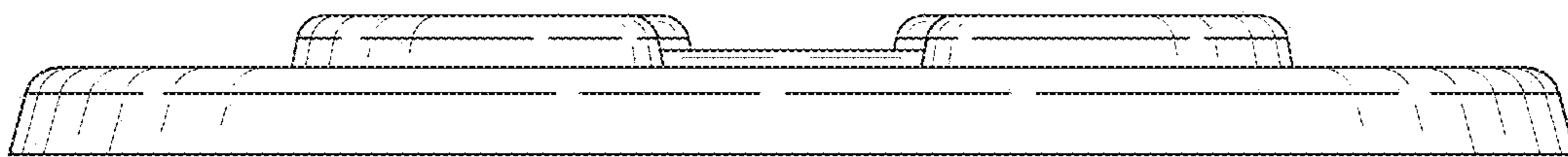

FIG. 17

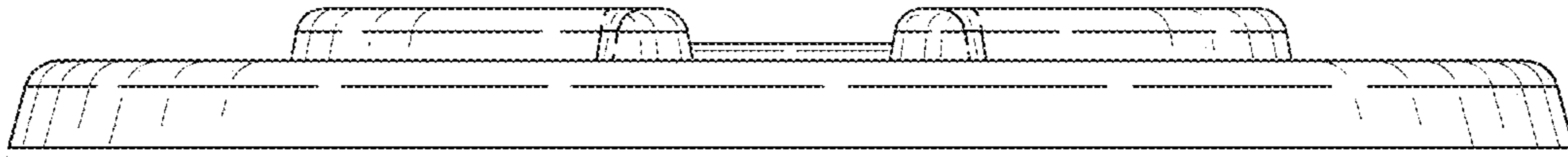

FIG. 18

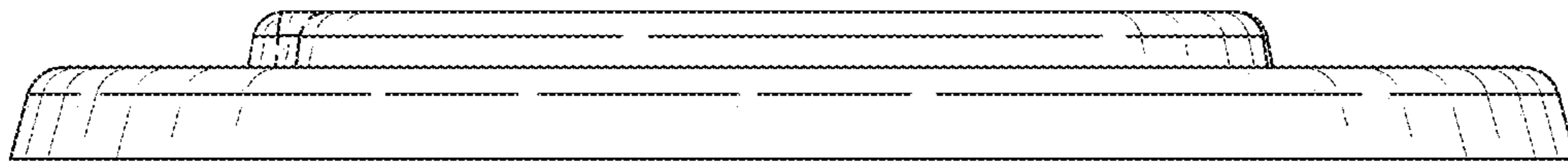

FIG. 19

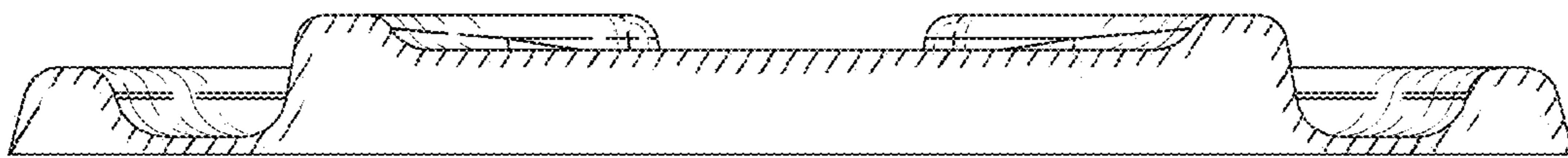

FIG. 20

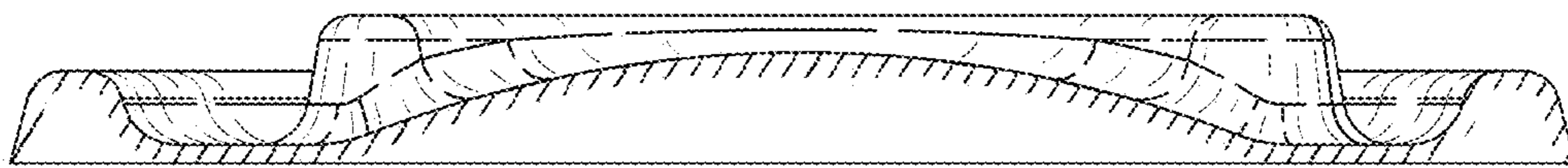

FIG. 21

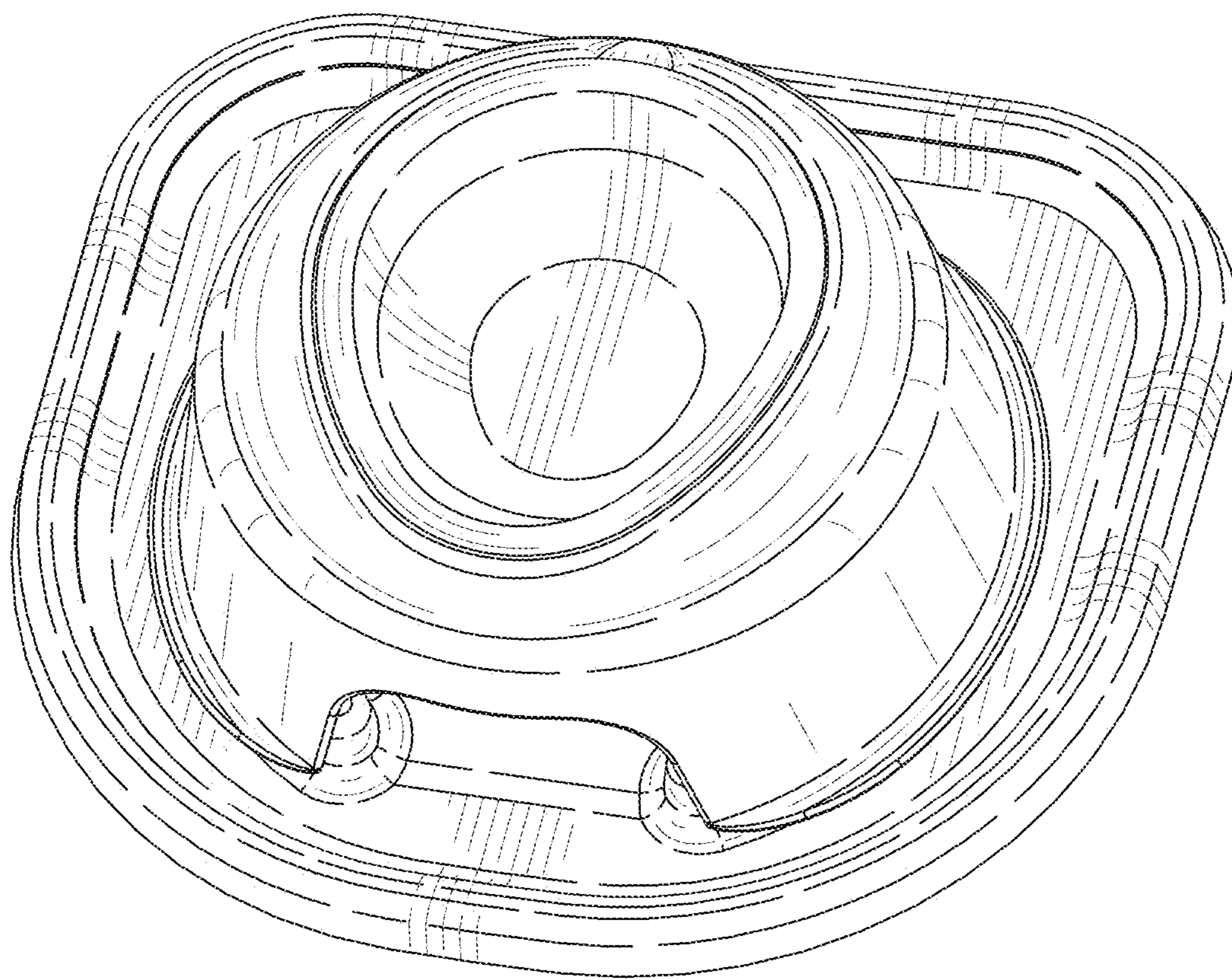

FIG. 22

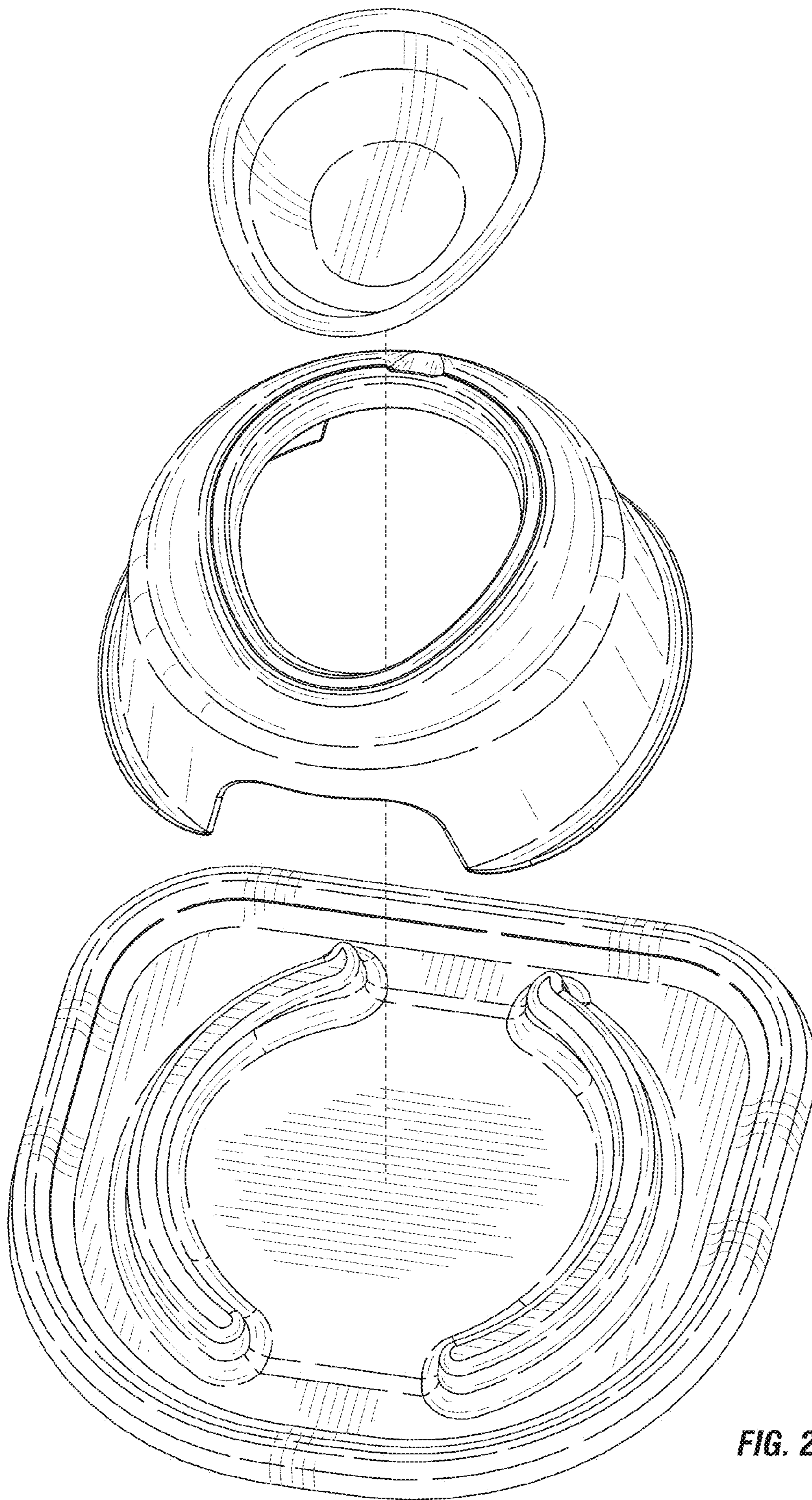

FIG. 23

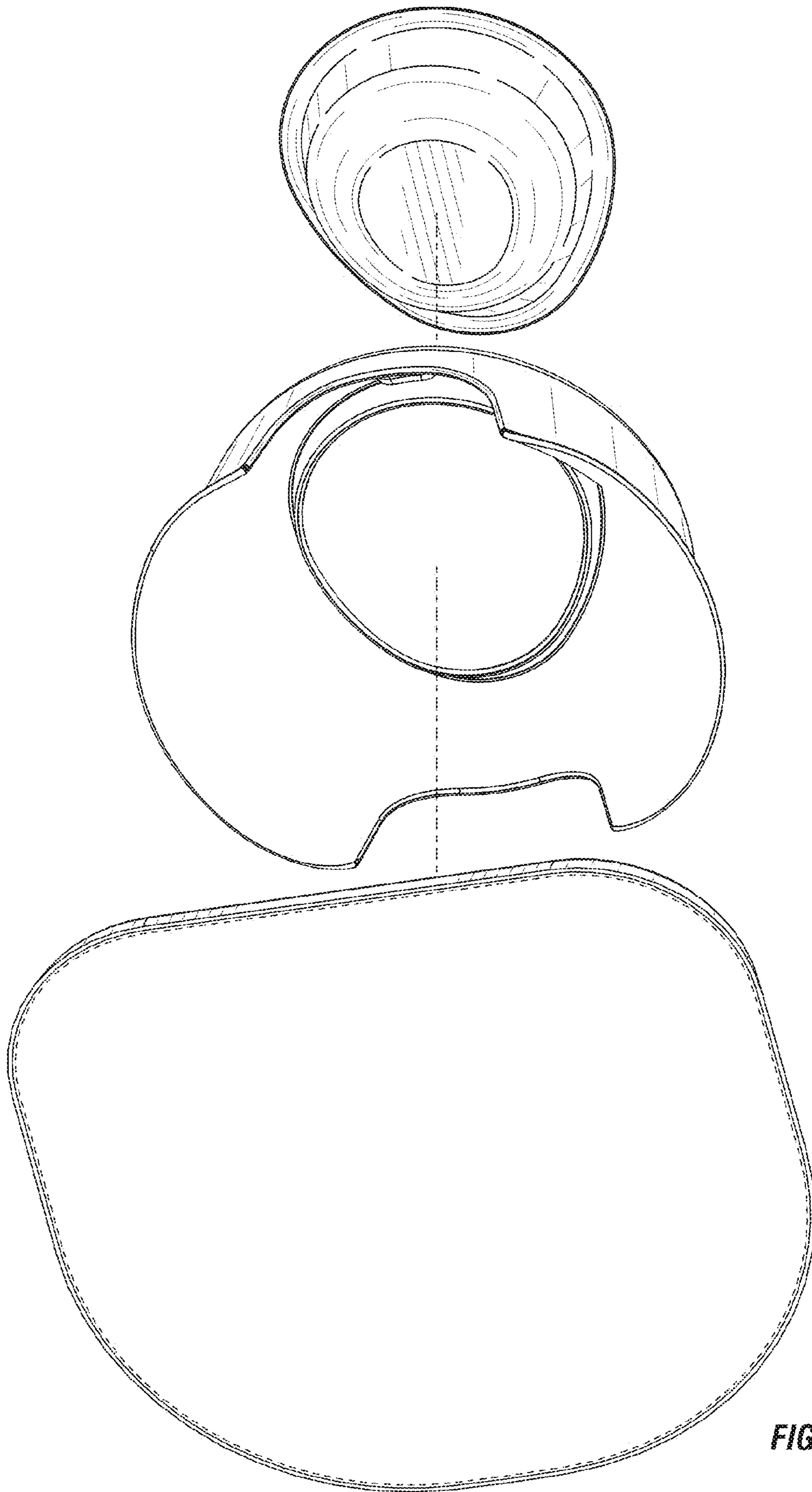

FIG. 24

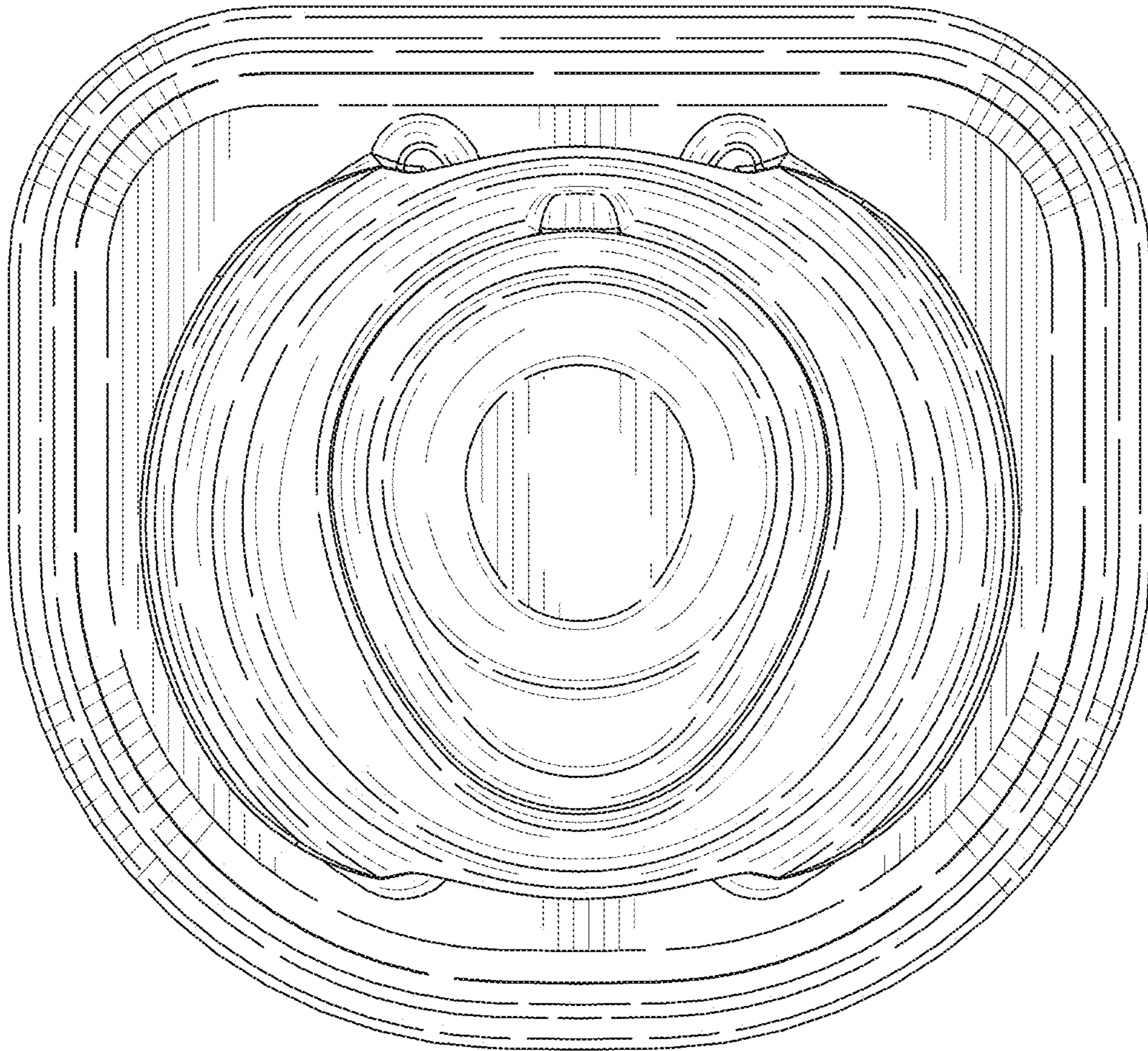

FIG. 25

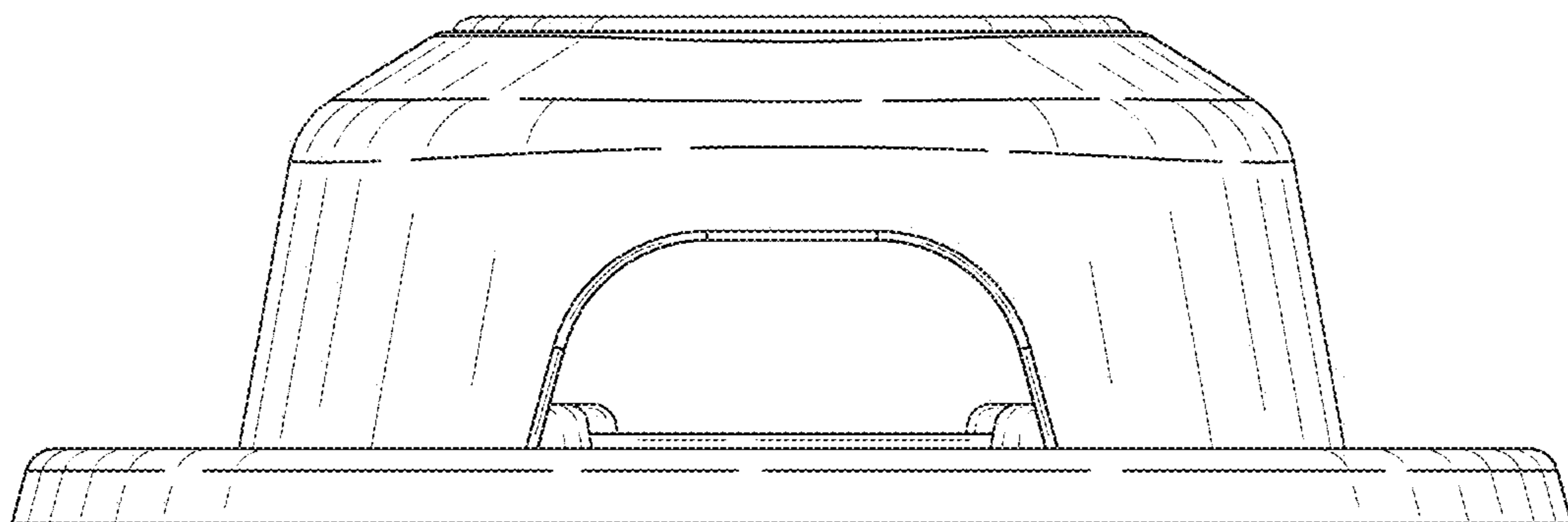

FIG. 26

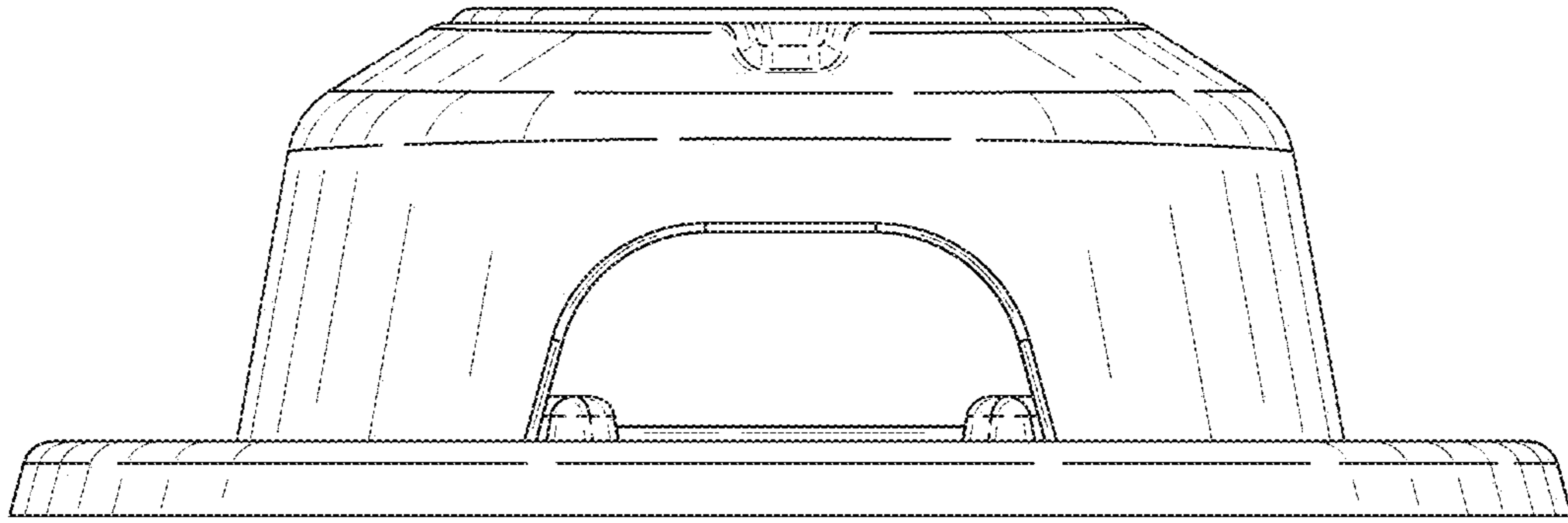

FIG. 27

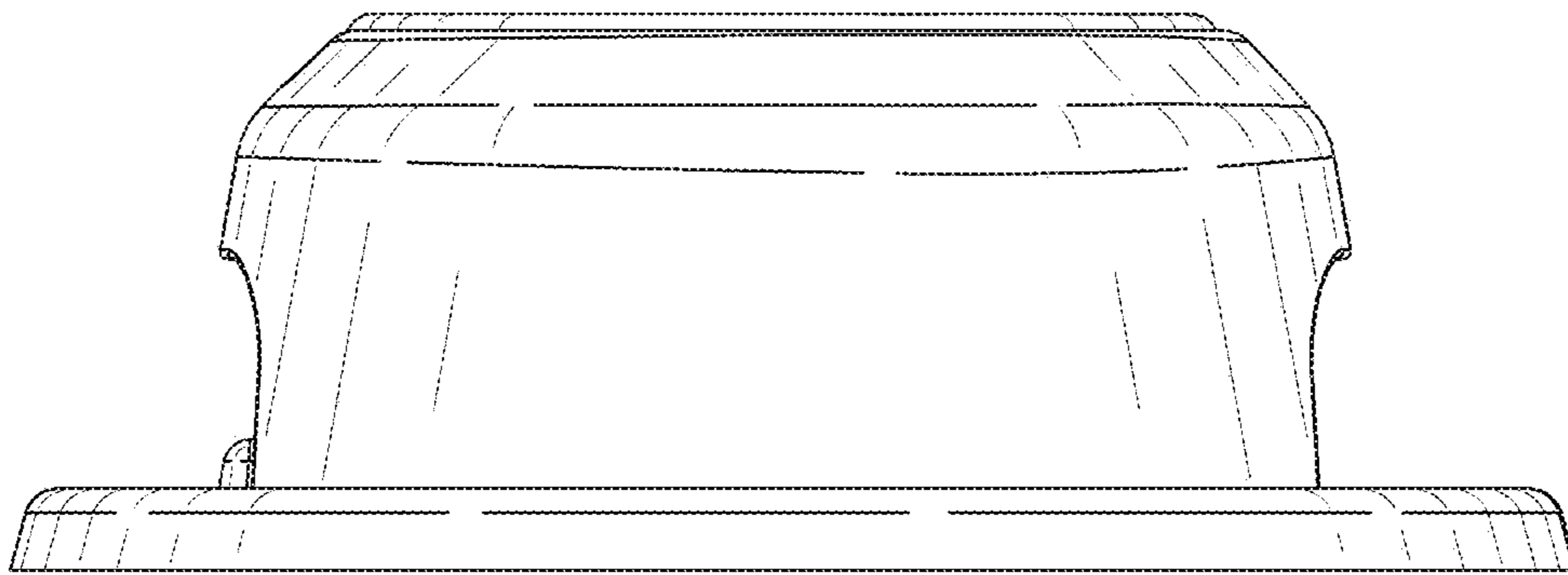

FIG. 28

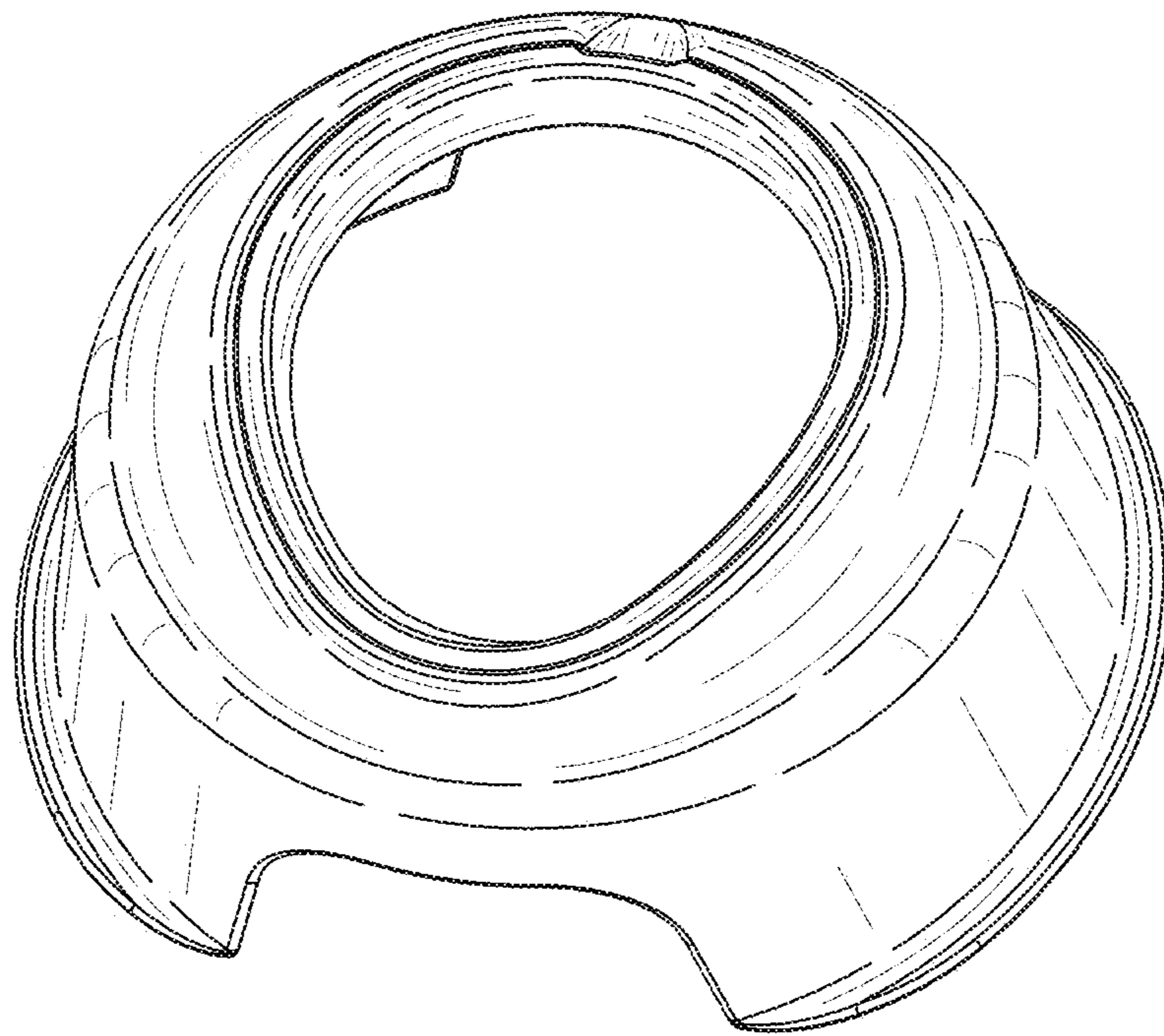

FIG. 29

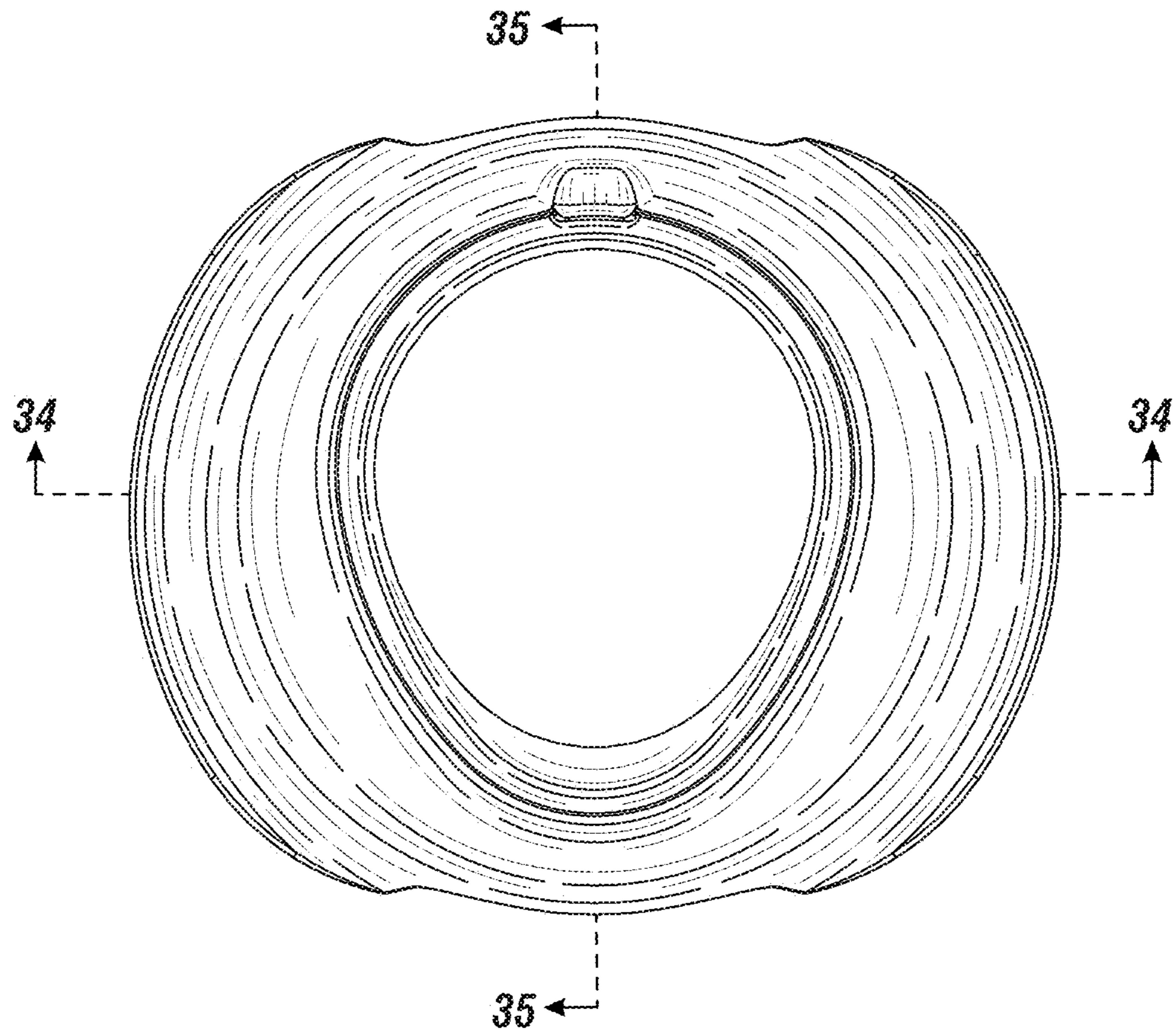

FIG. 30

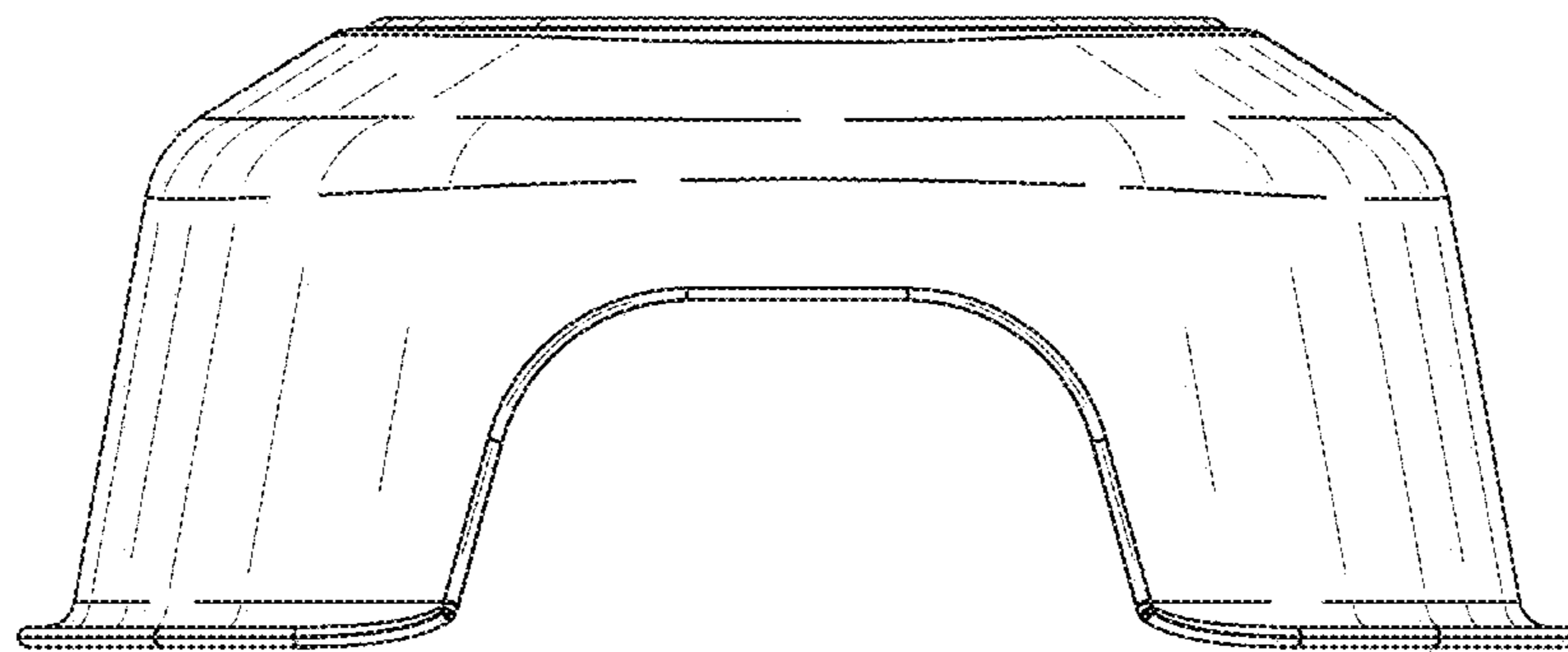

FIG. 31

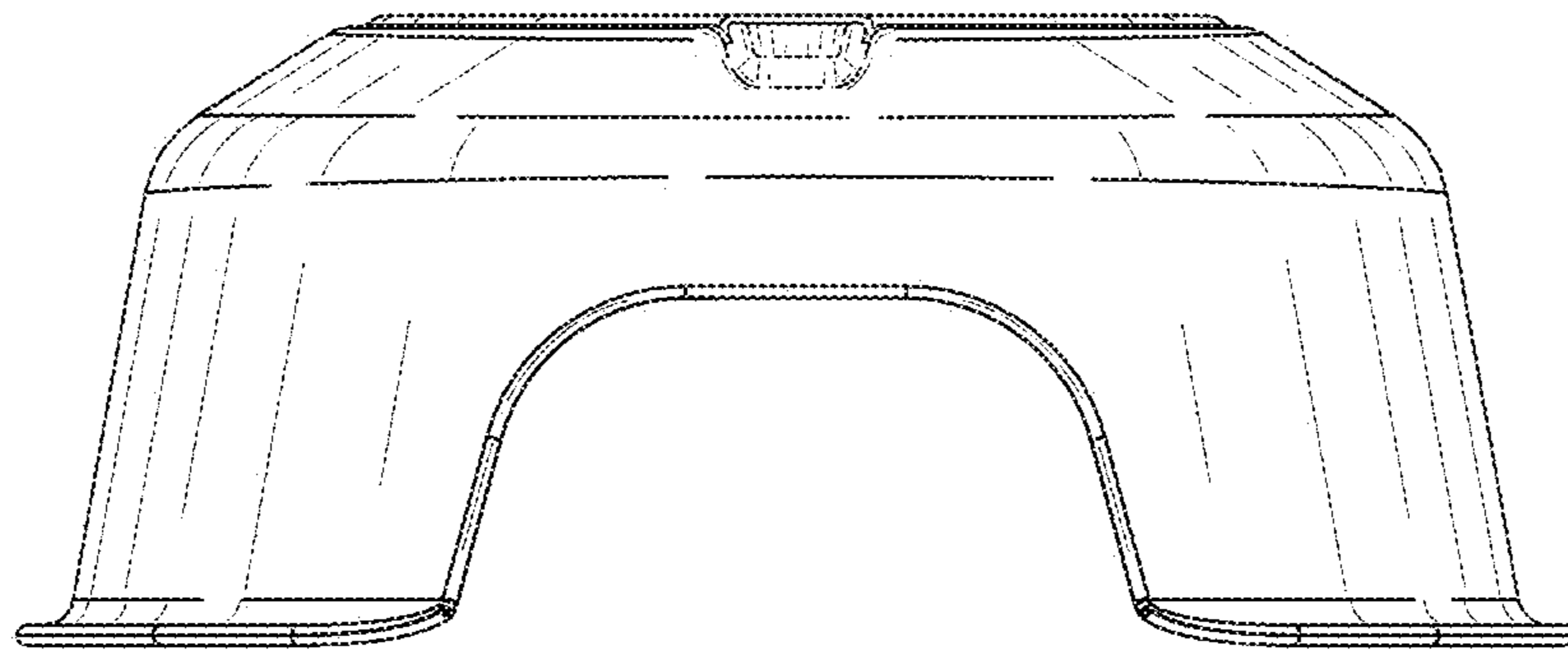

FIG. 32

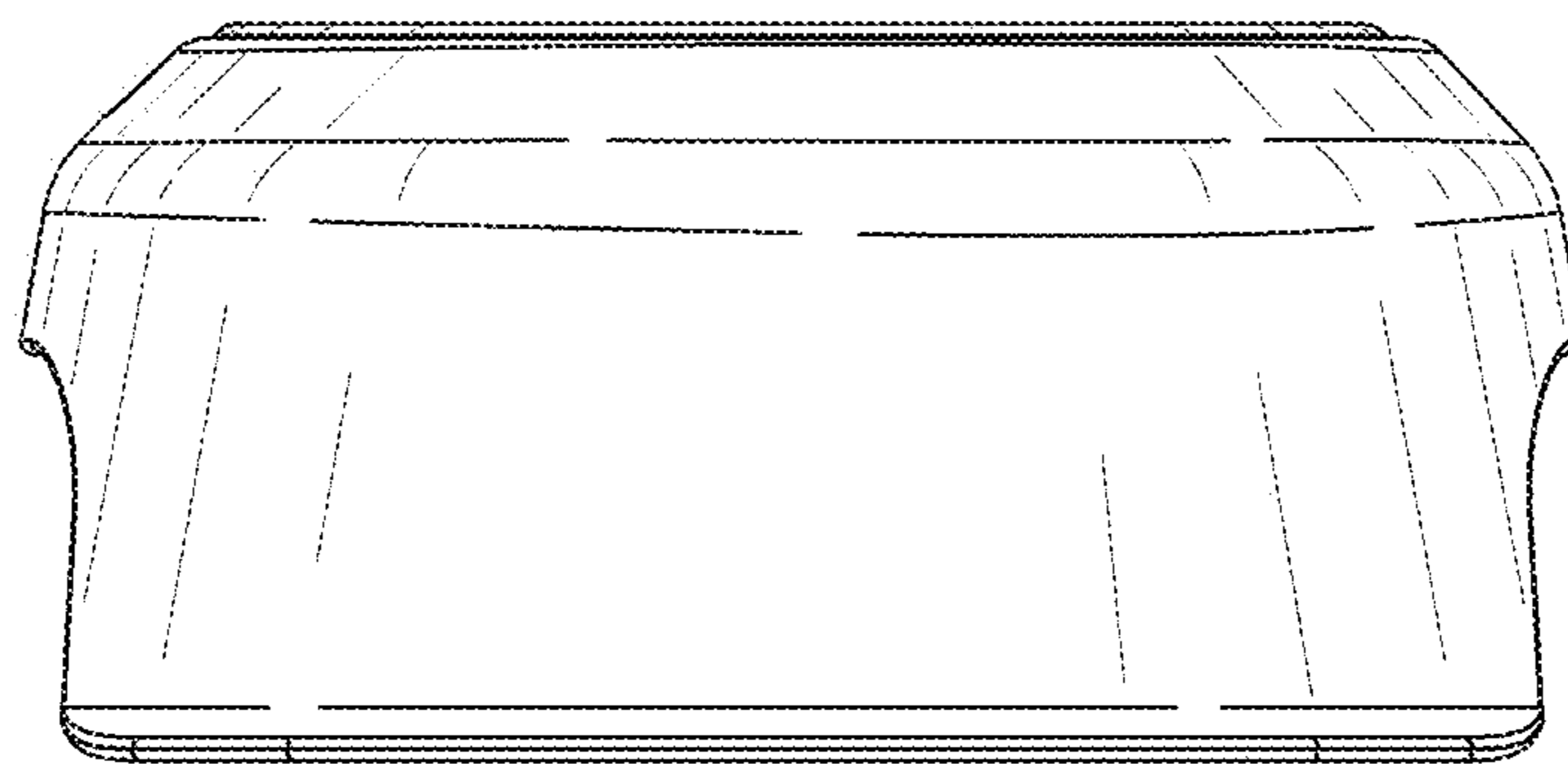

FIG. 33

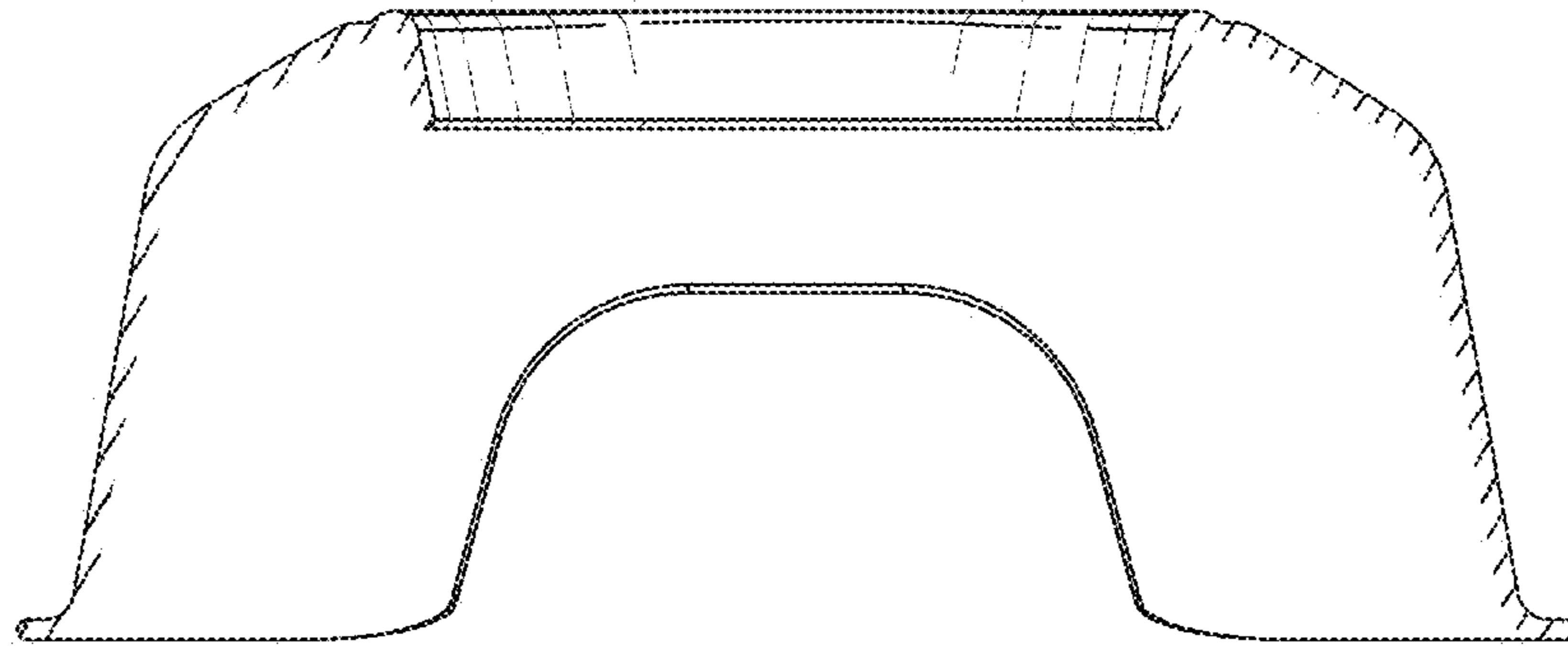

FIG. 34

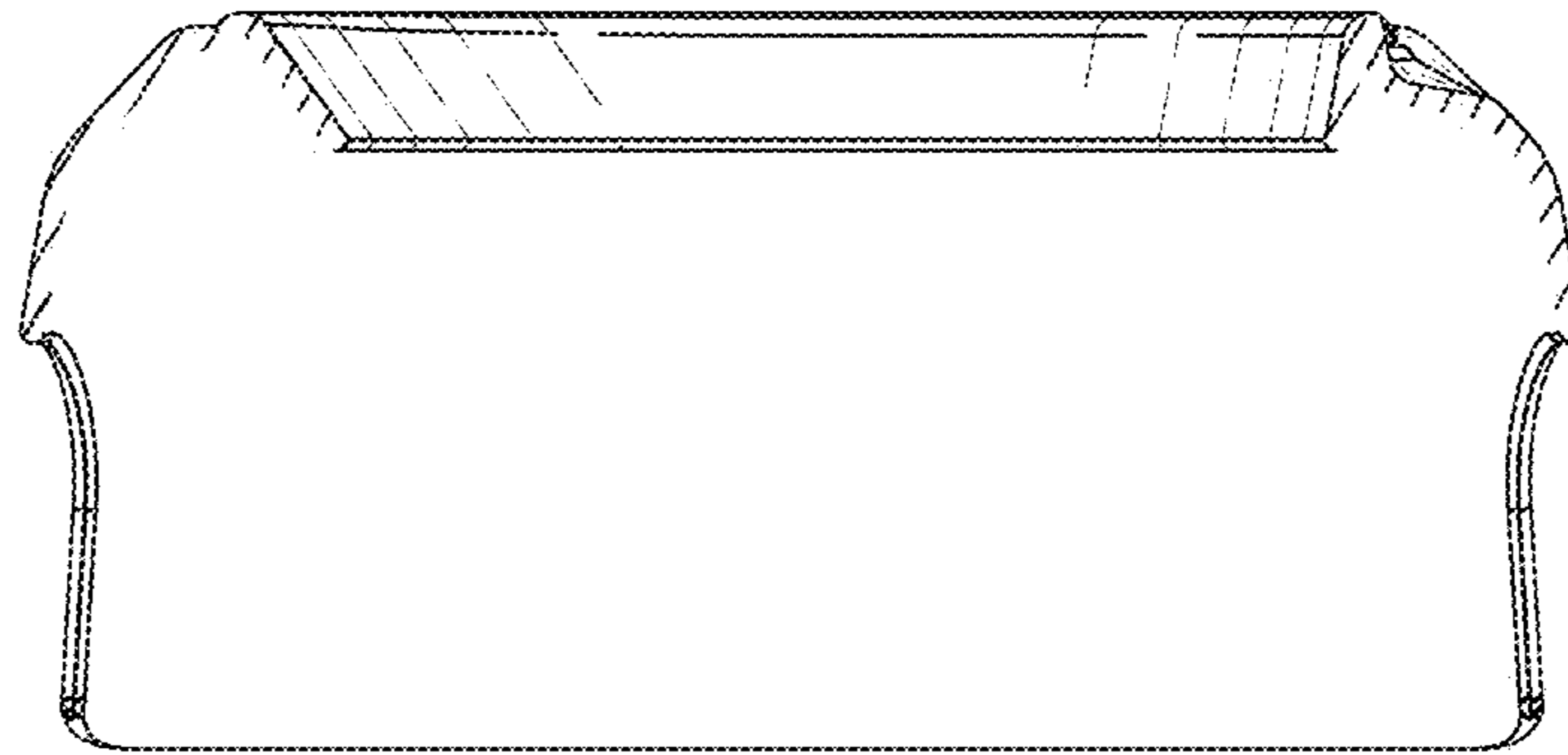

FIG. 35

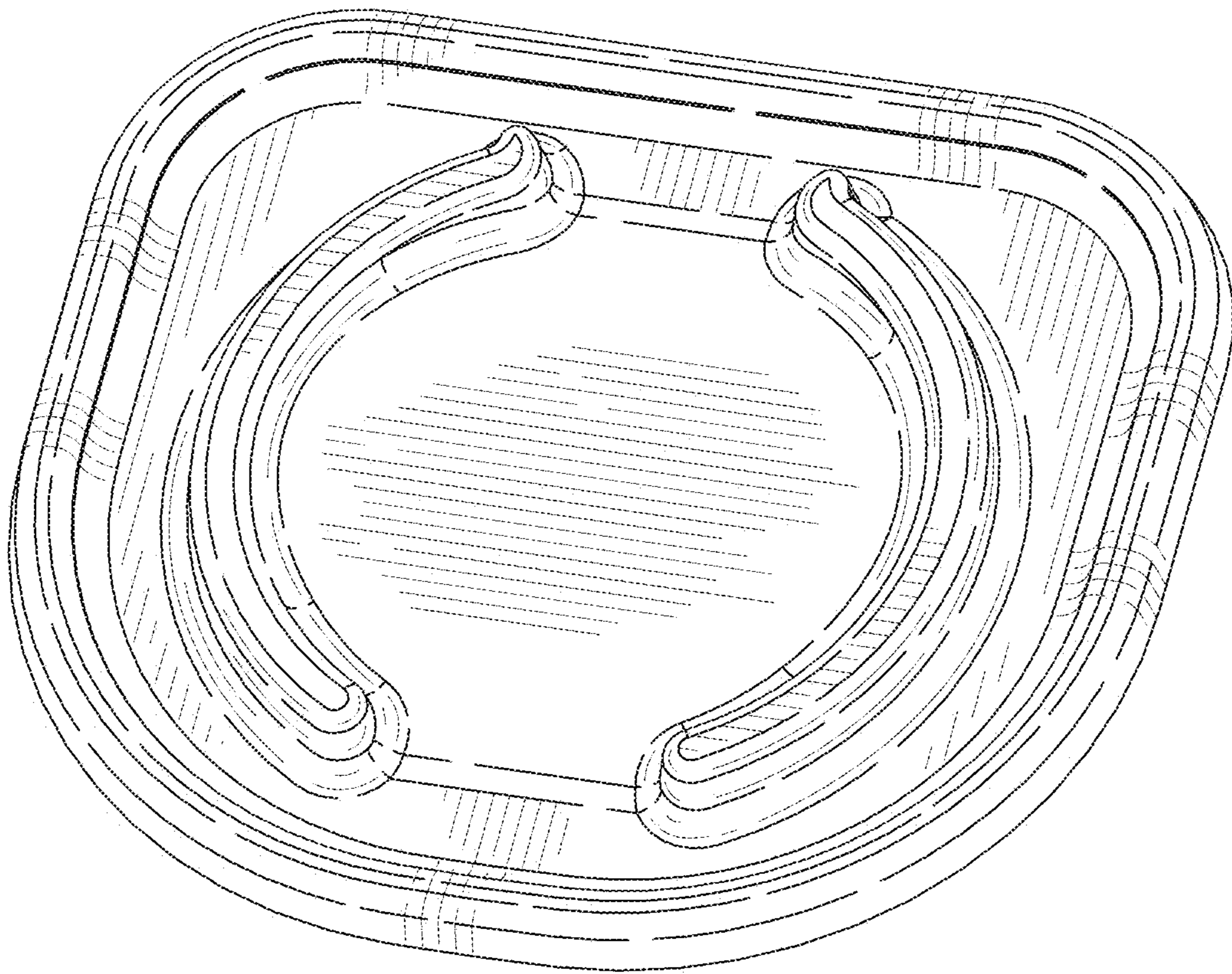

FIG. 36

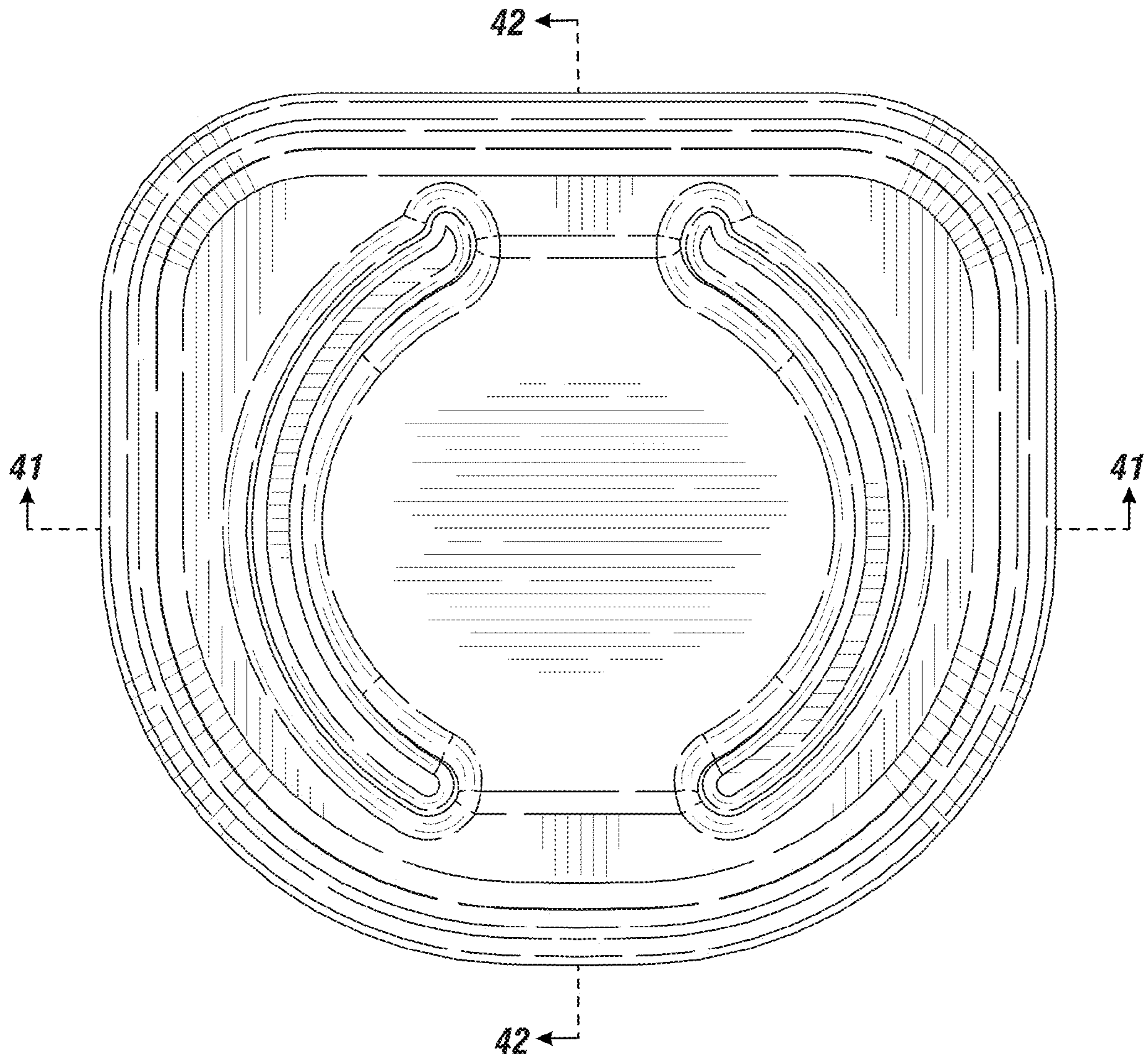

FIG. 37

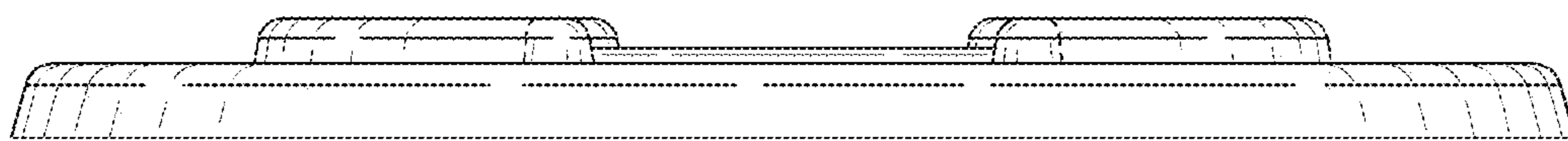

FIG. 38

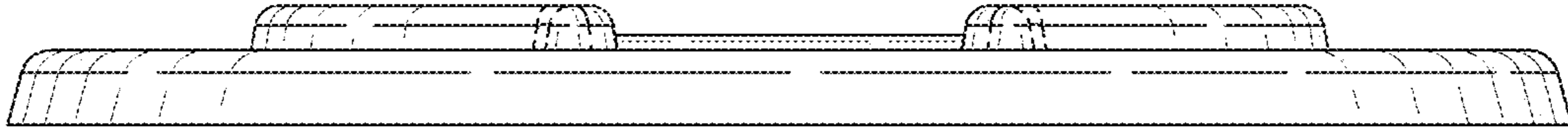

FIG. 39

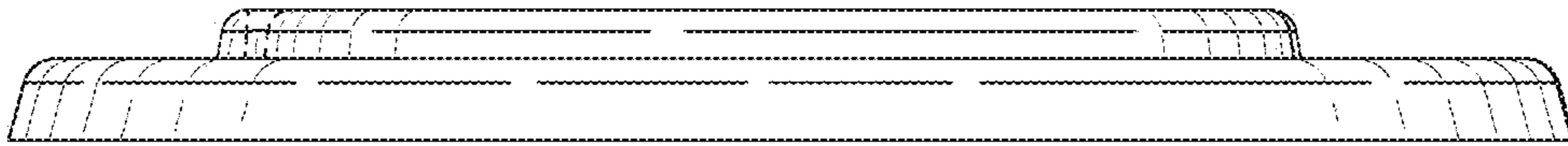

FIG. 40

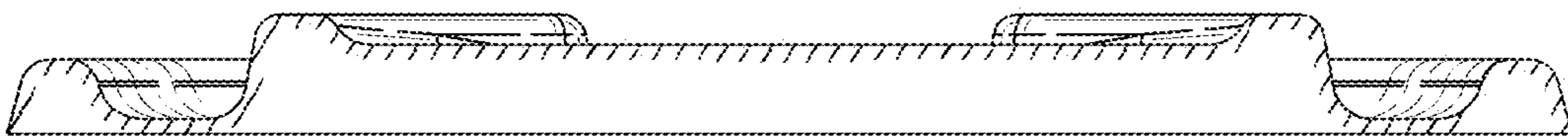

FIG. 41

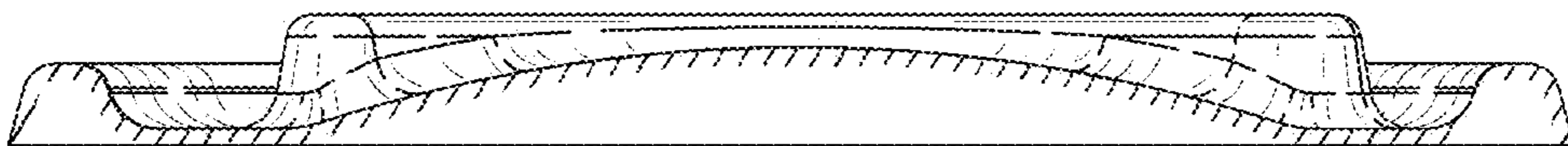

FIG. 42

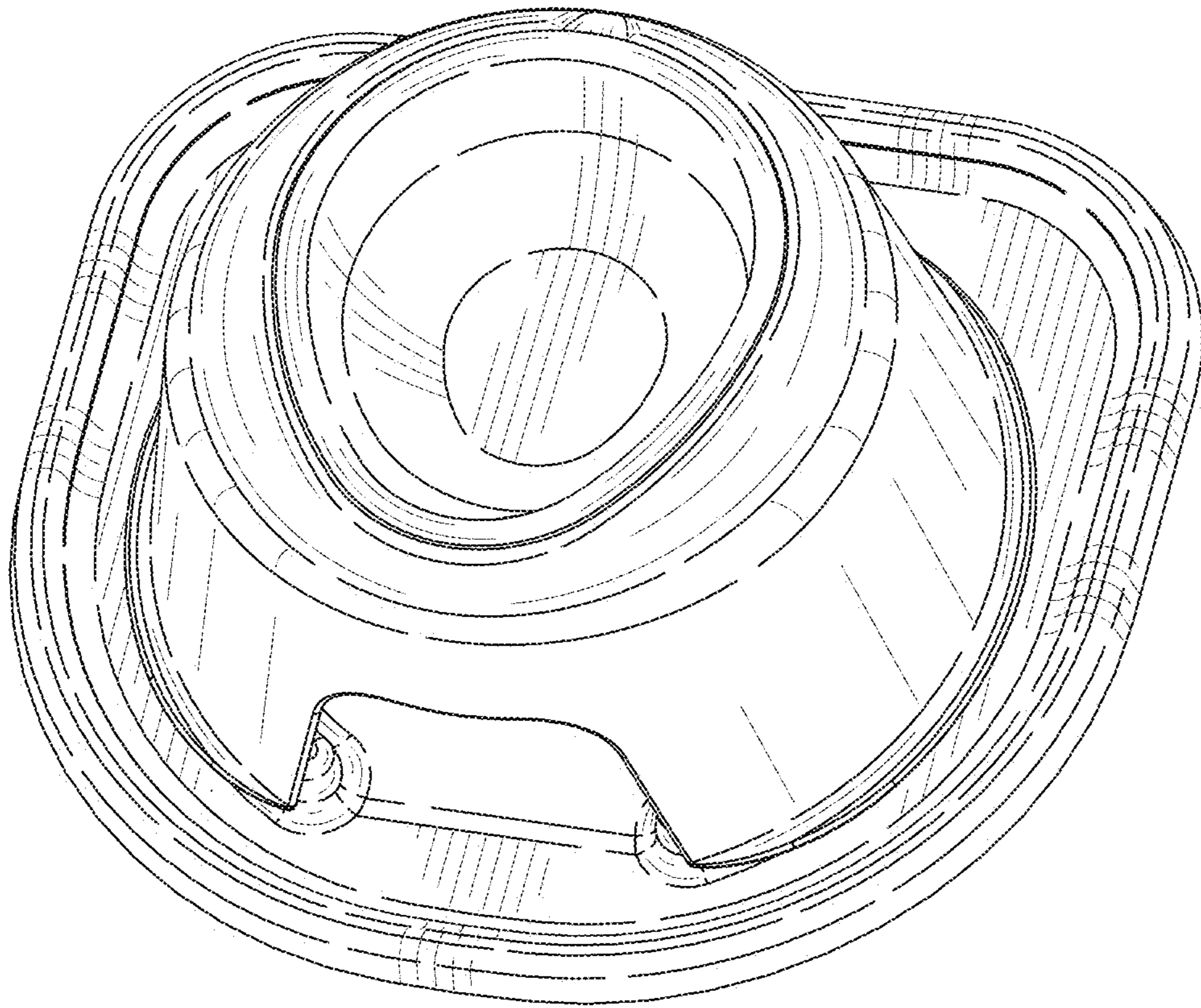

FIG. 43

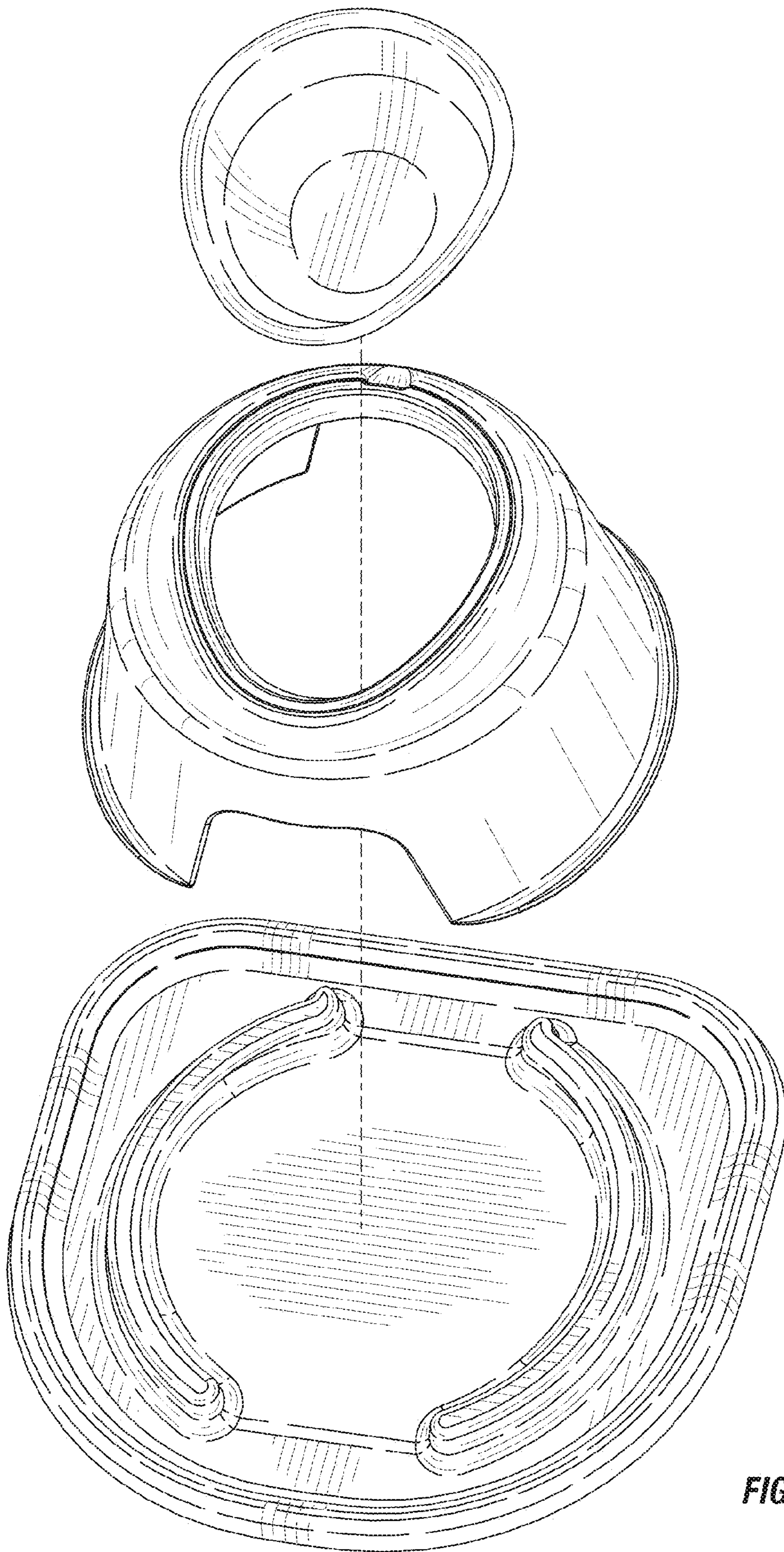

FIG. 44

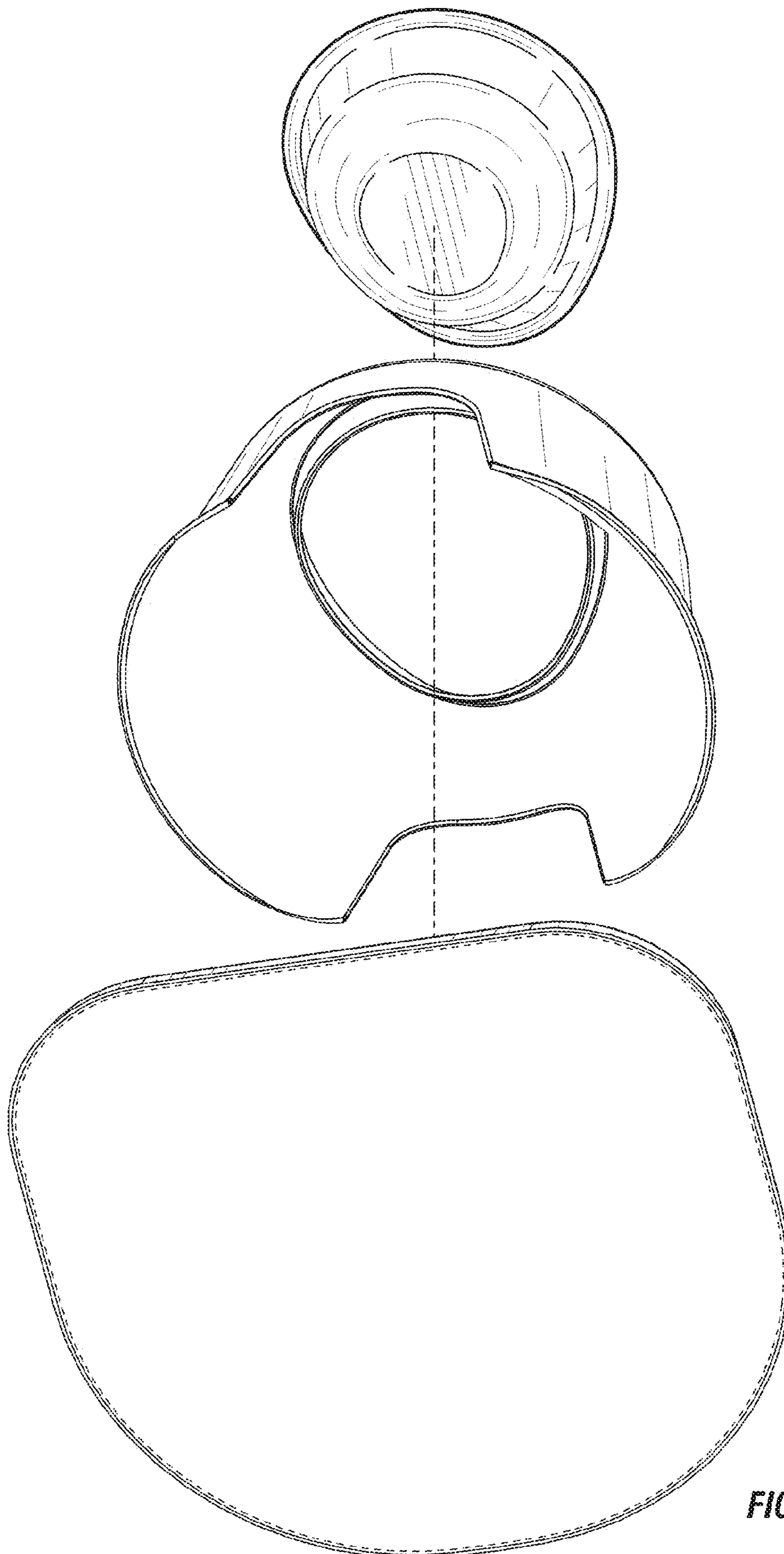

FIG. 45

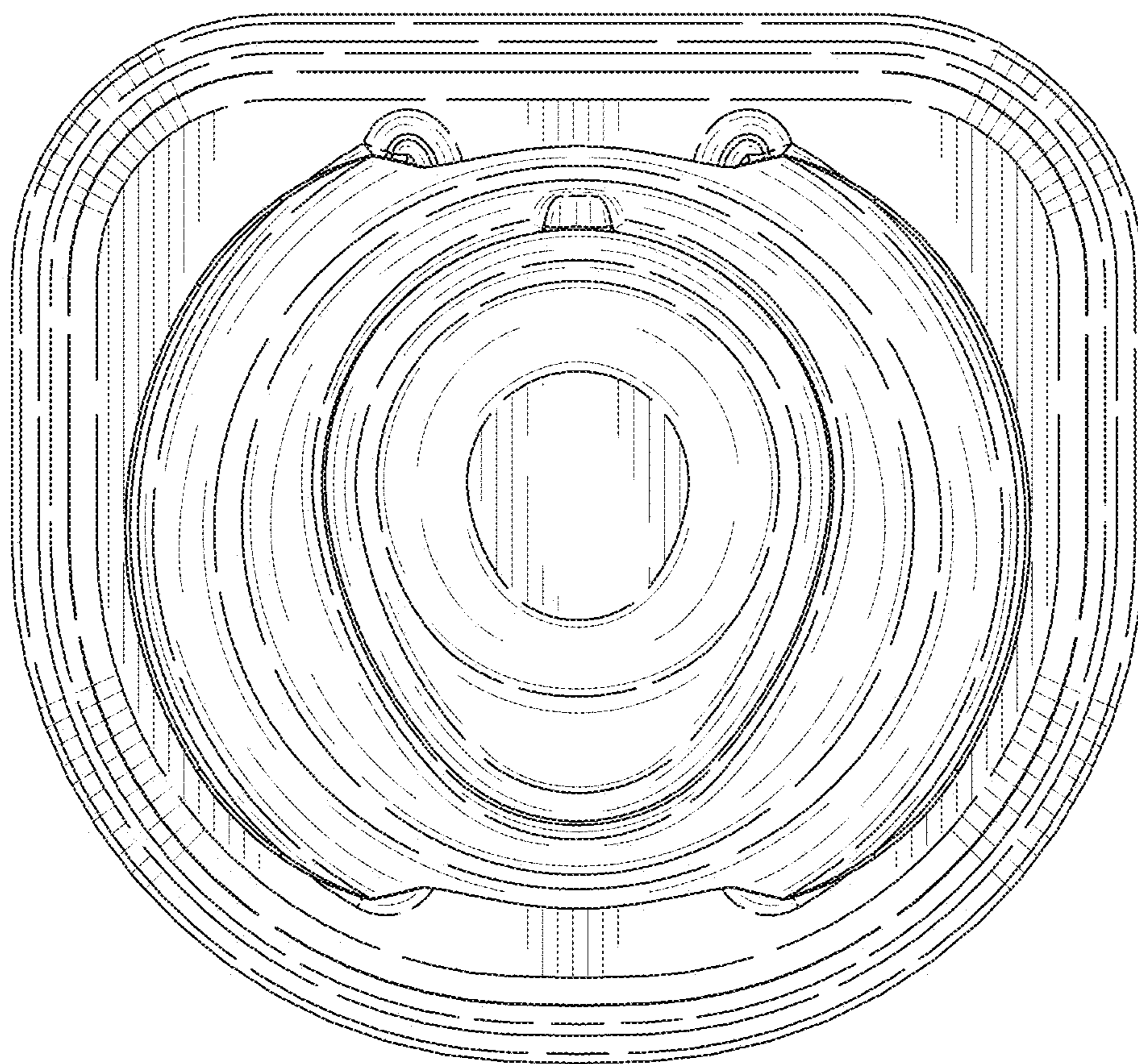

FIG. 46

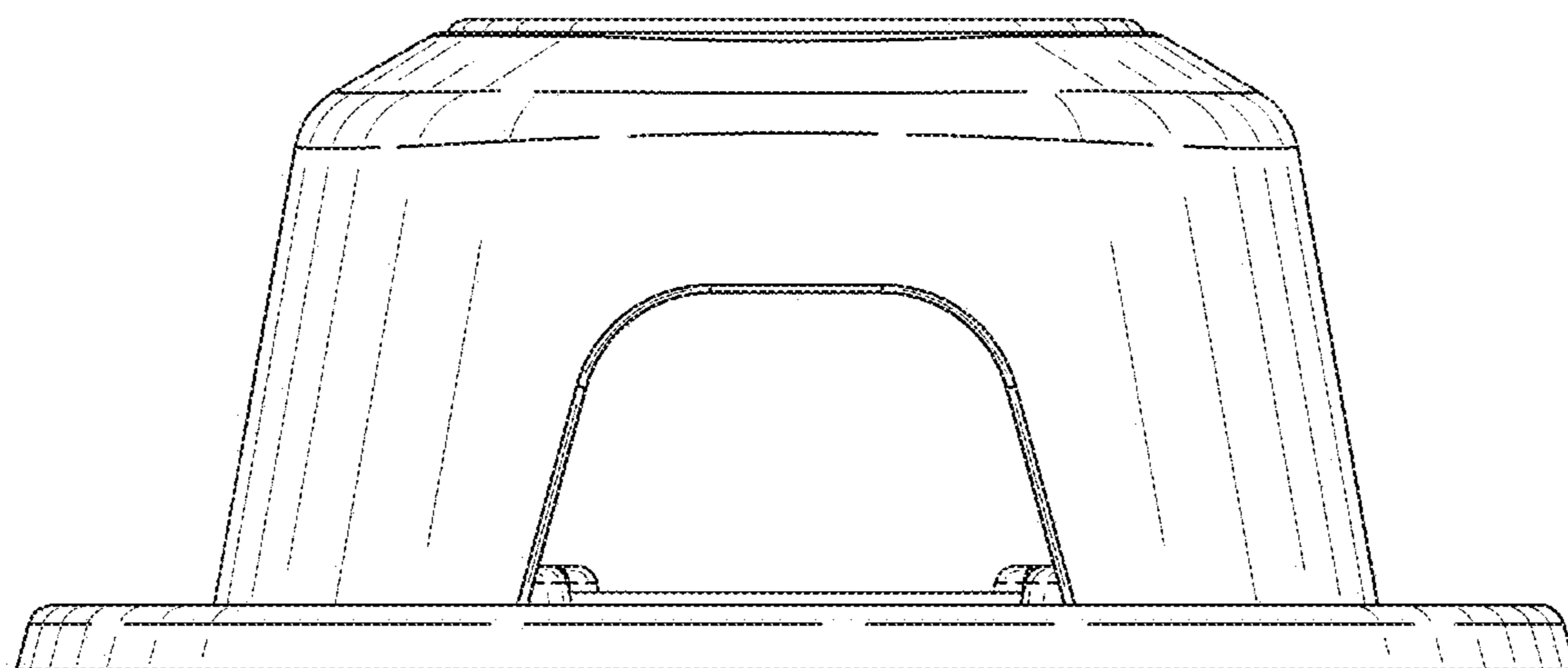

FIG. 47

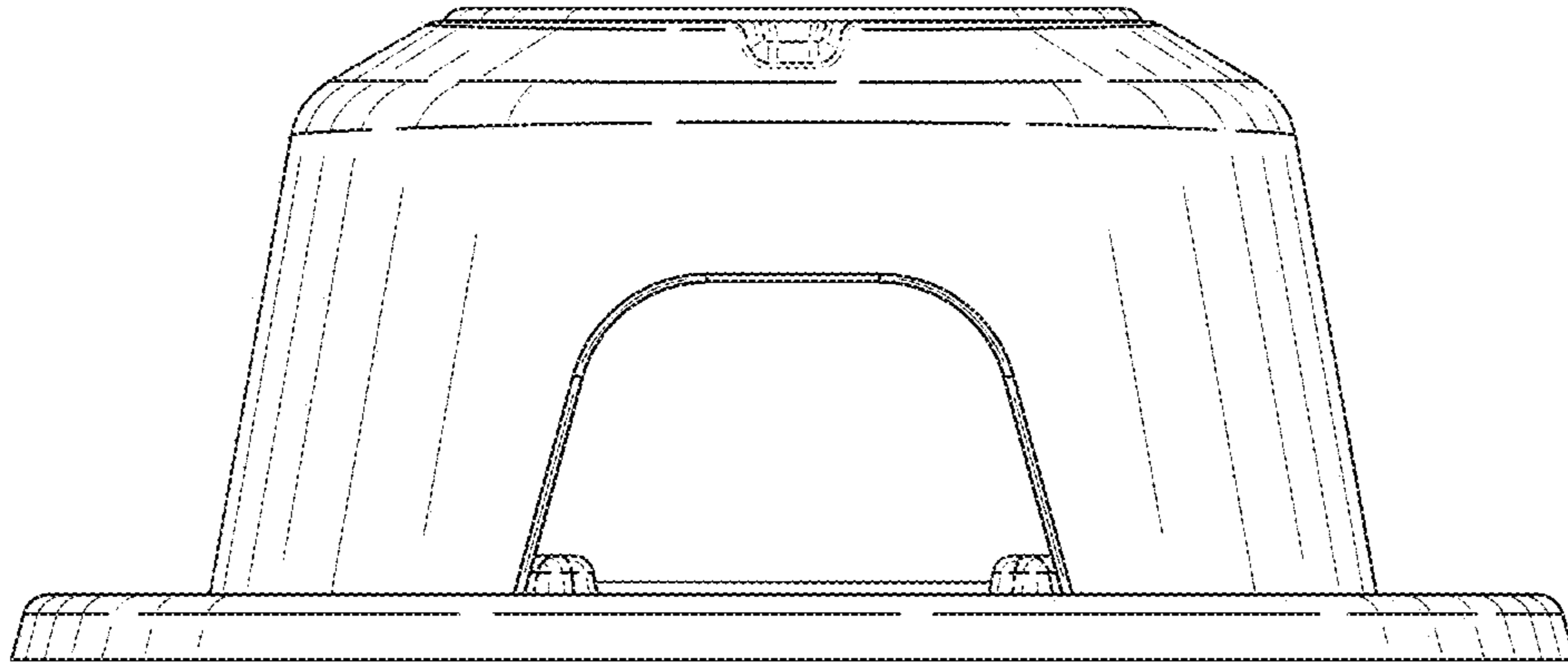

FIG. 48

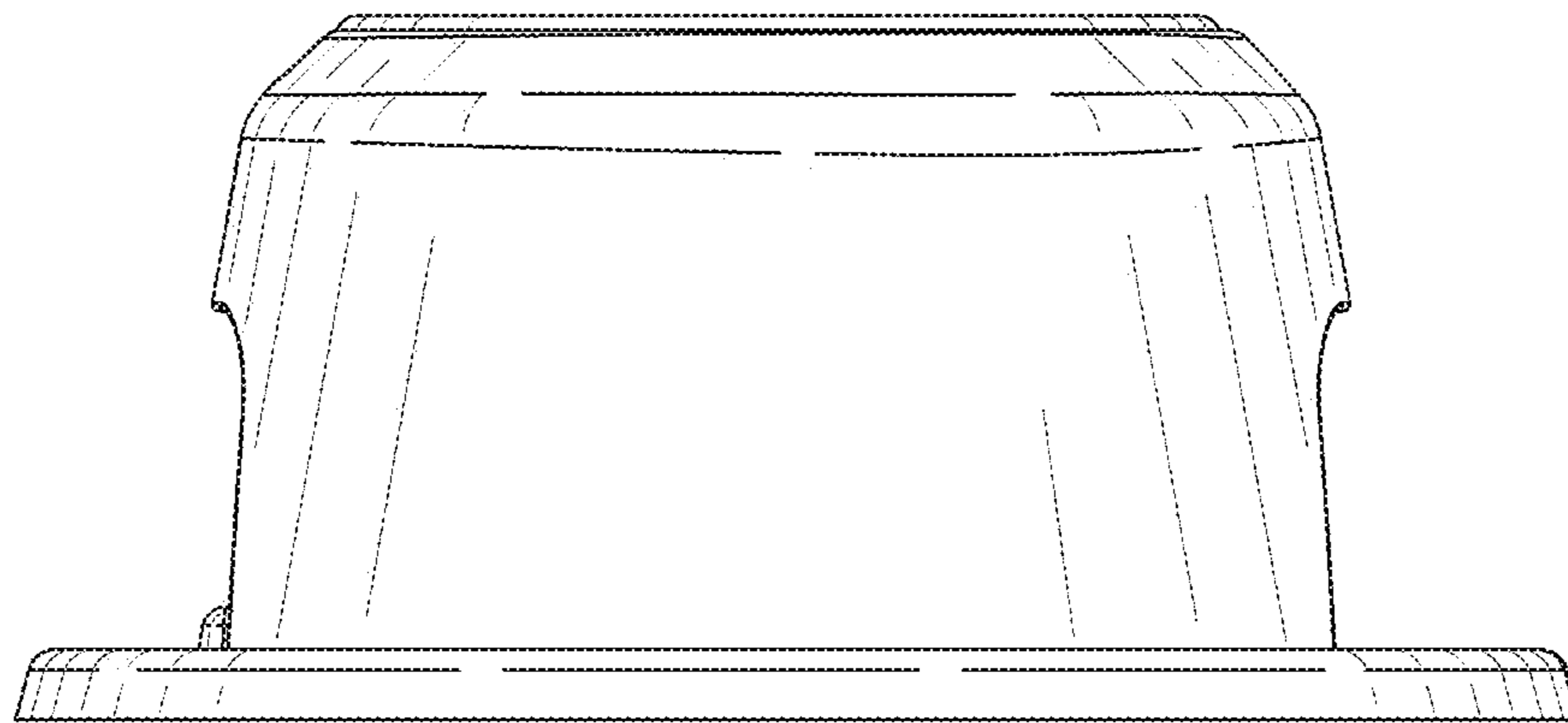

FIG. 49

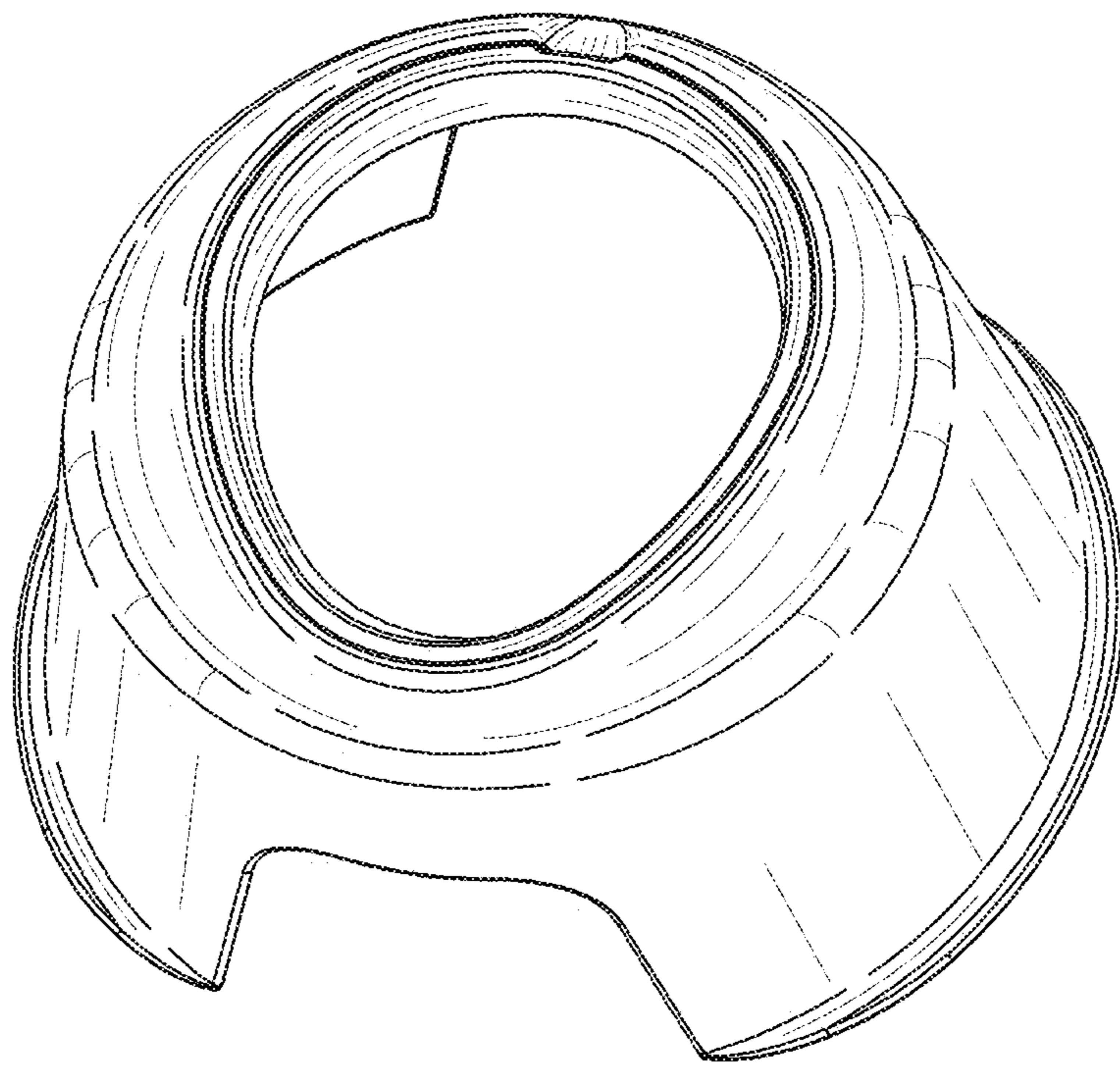

FIG. 50

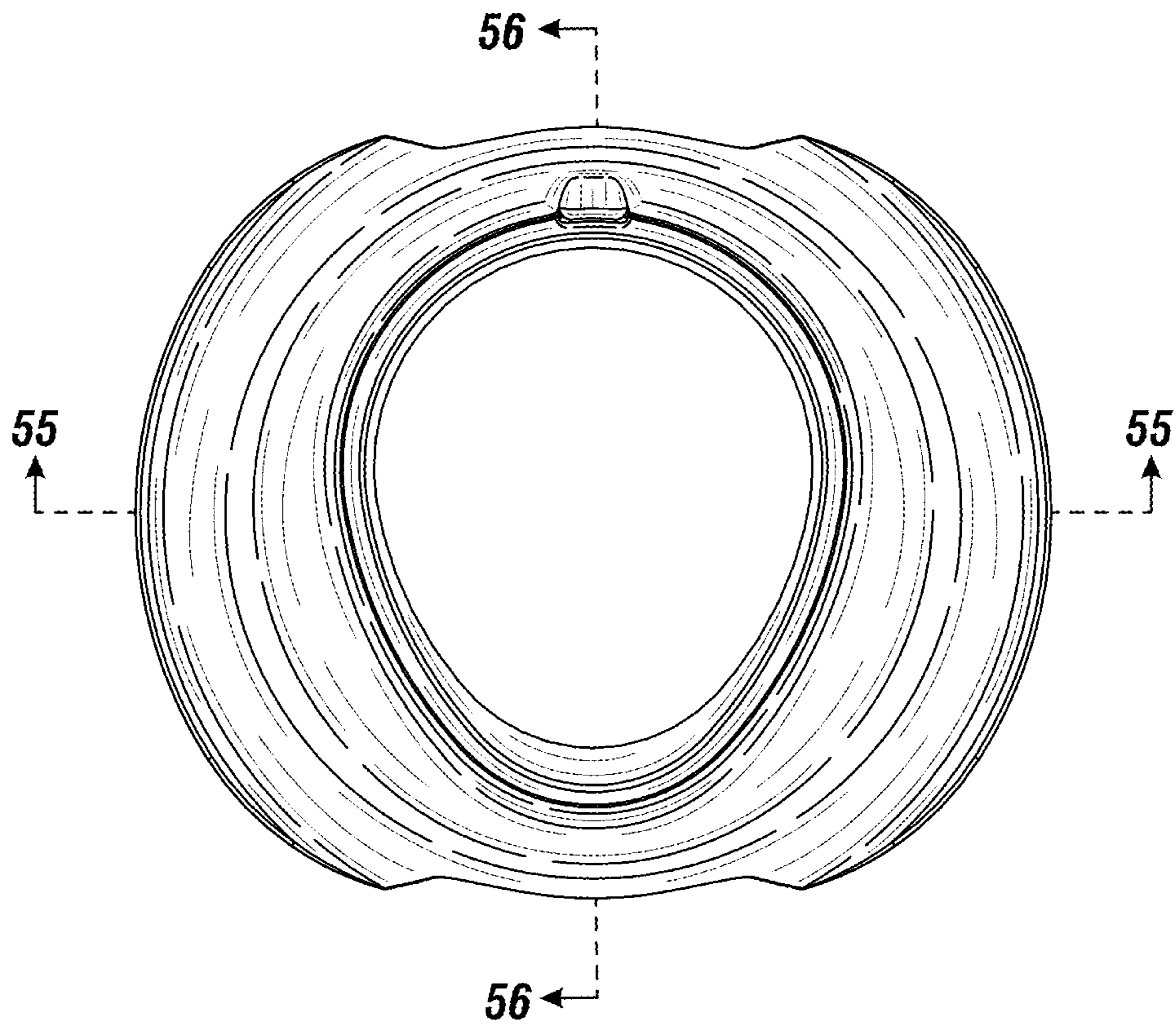

FIG. 51

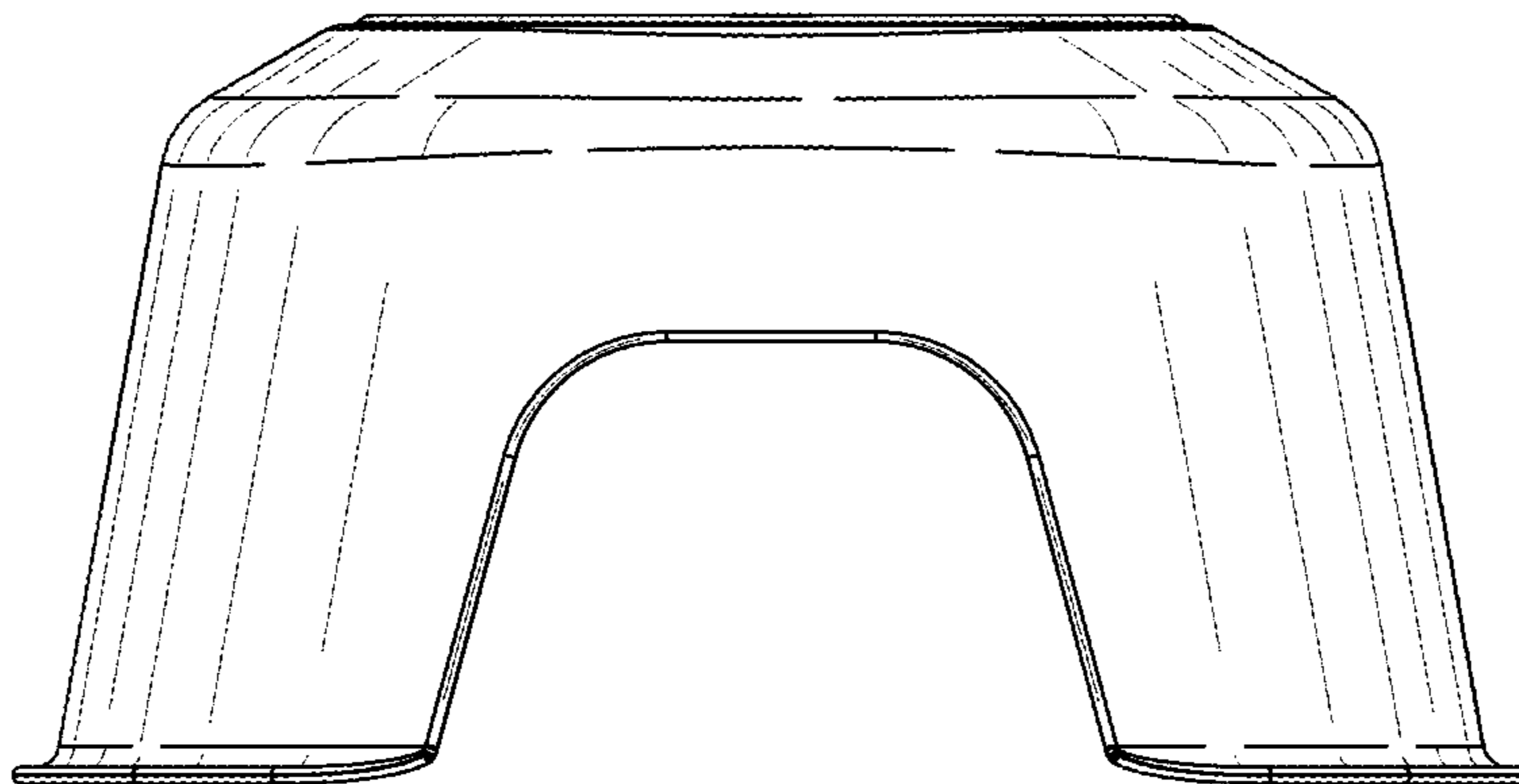

FIG. 52

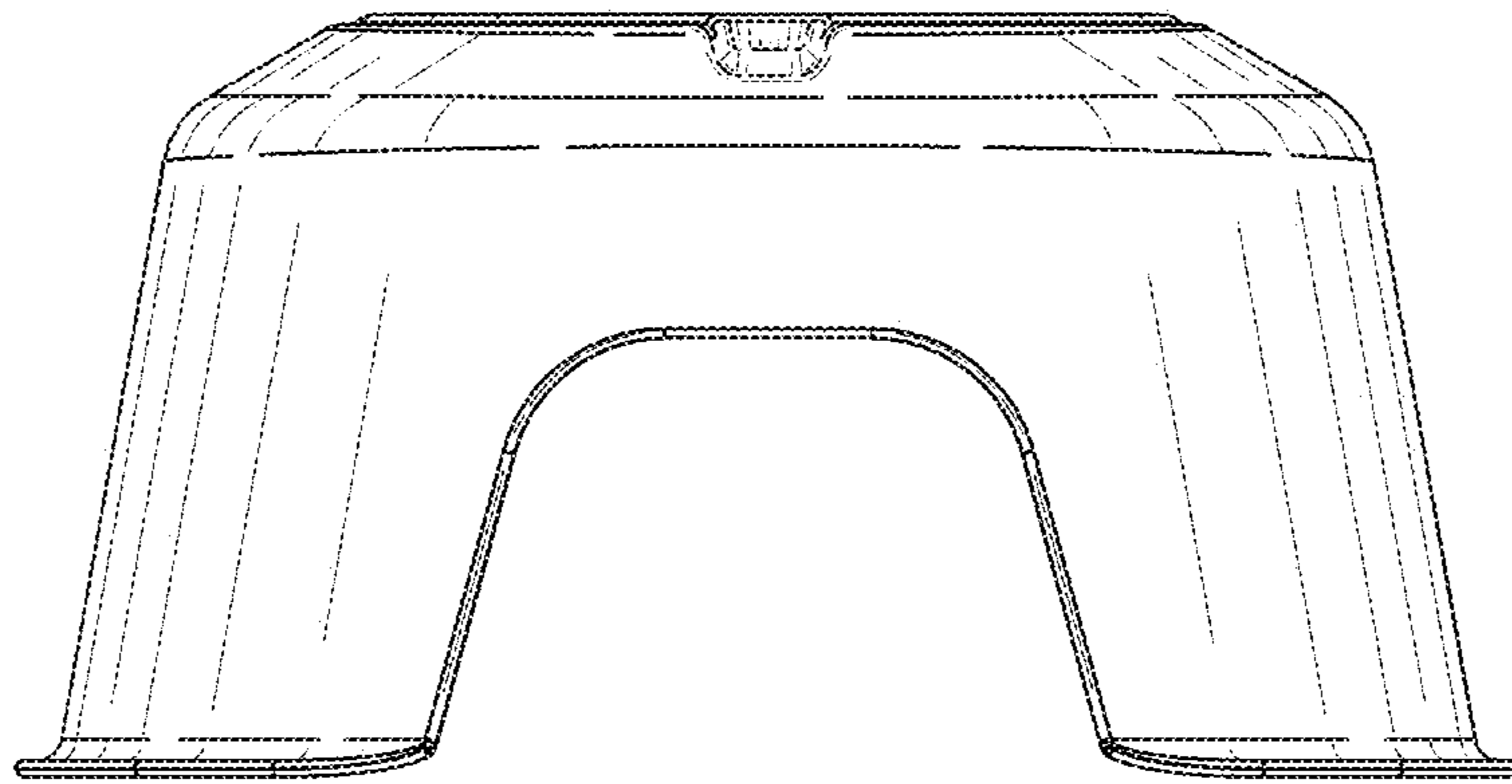

FIG. 53

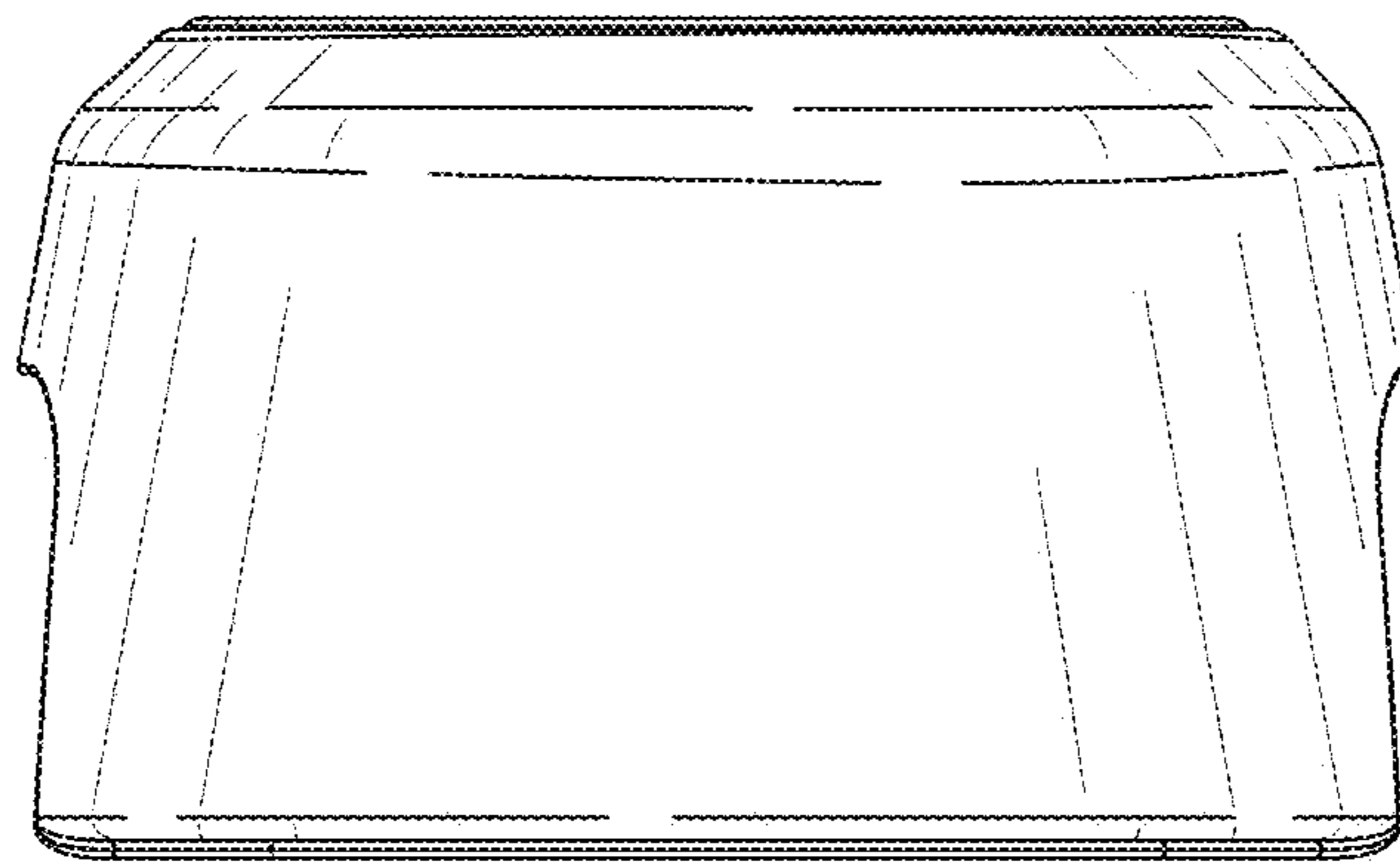

FIG. 54

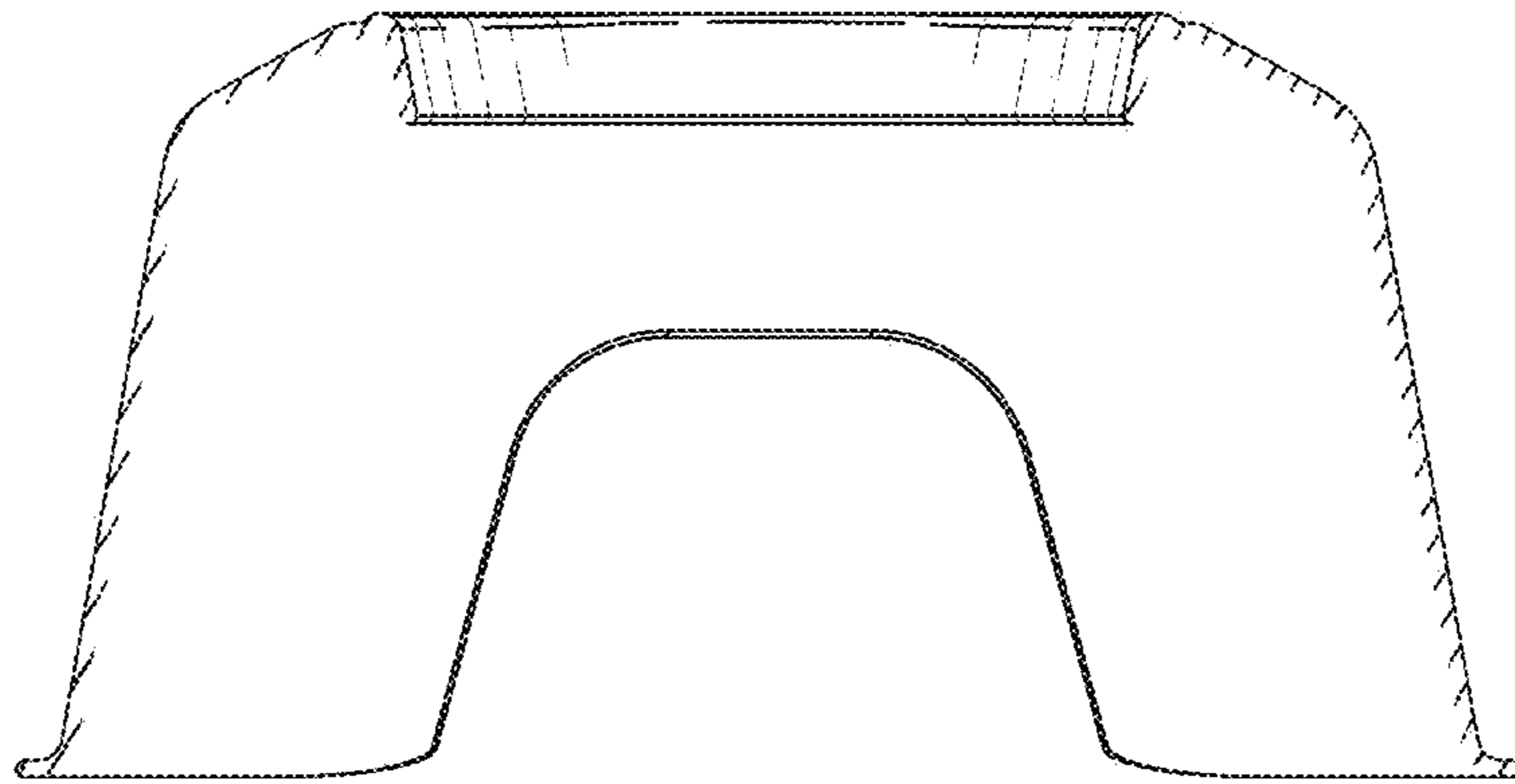

FIG. 55

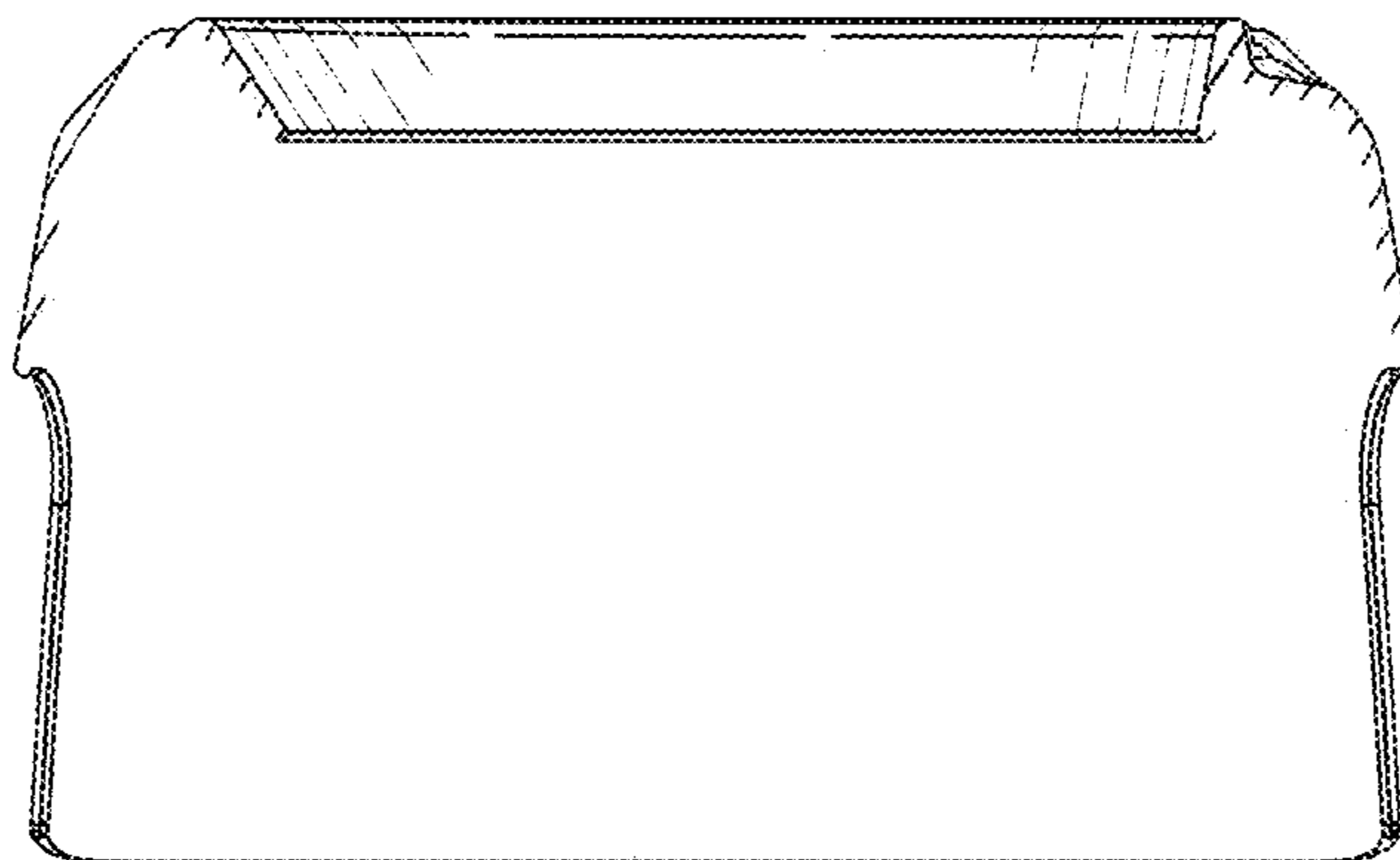

FIG. 56

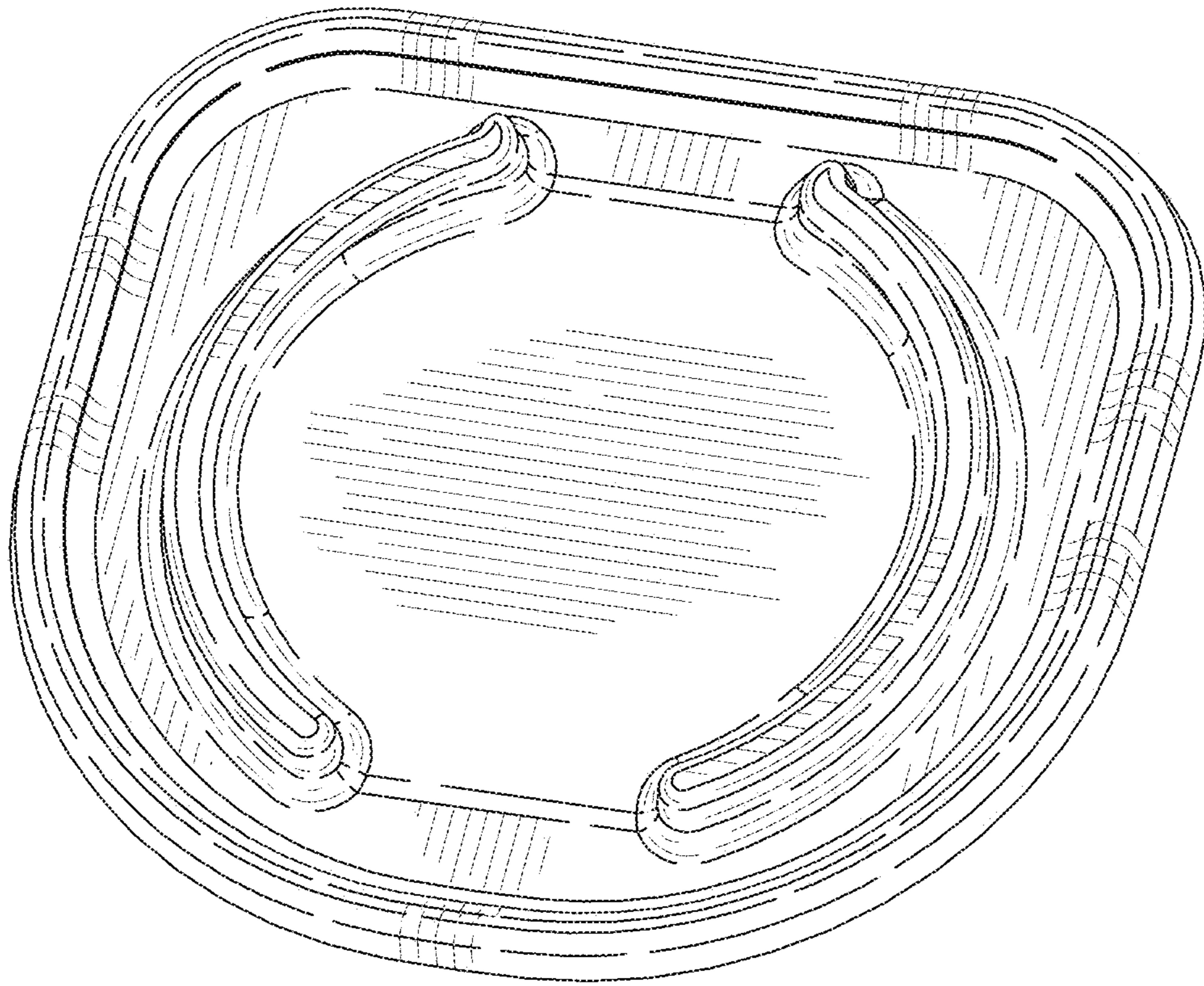

FIG. 57

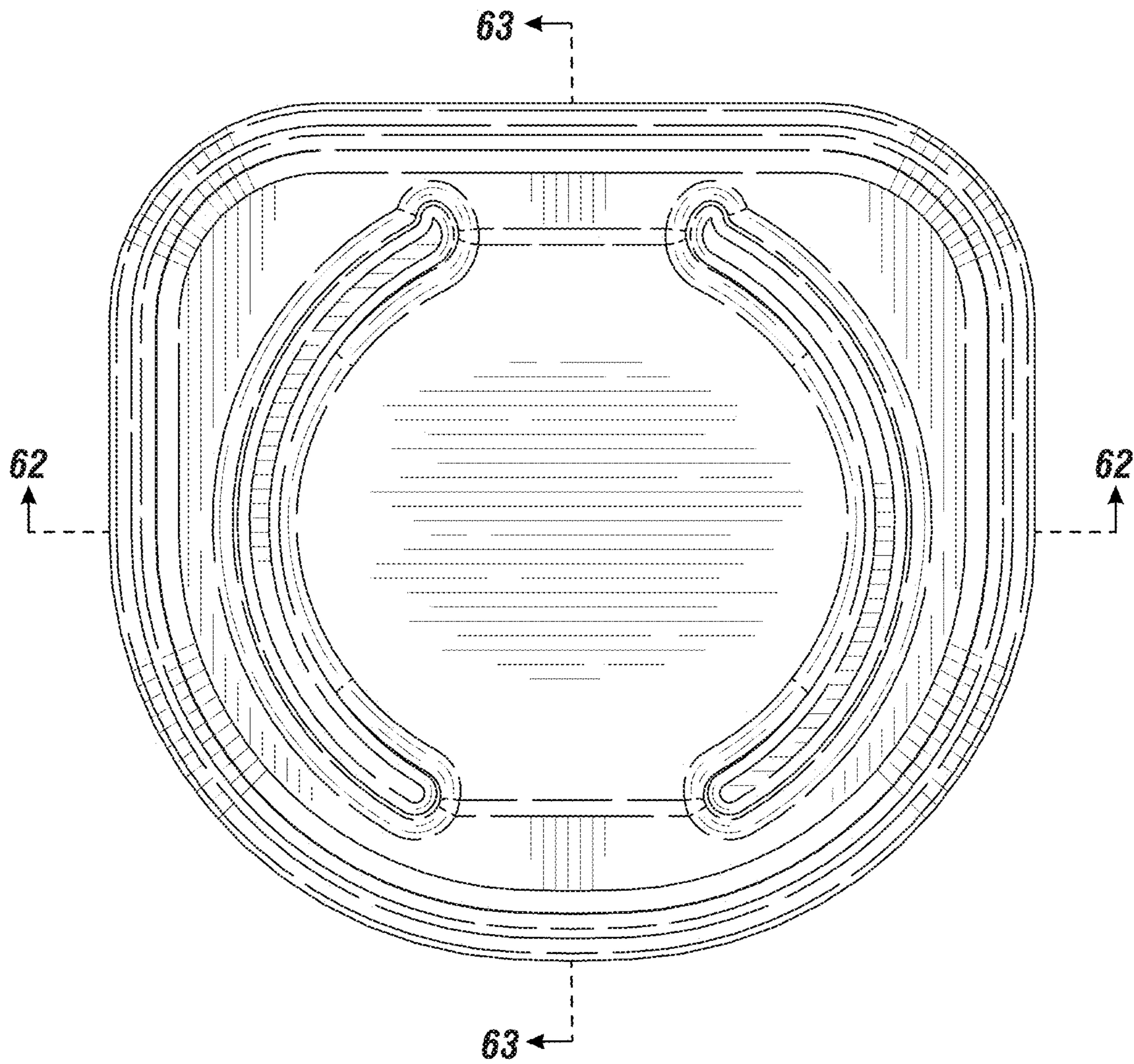

FIG. 58

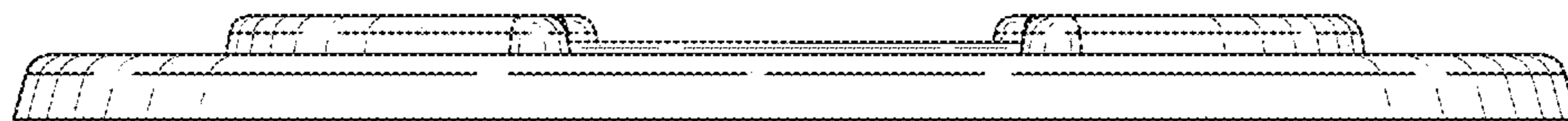

FIG. 59

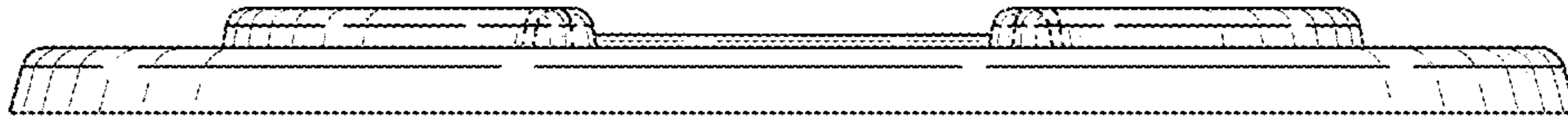

FIG. 60

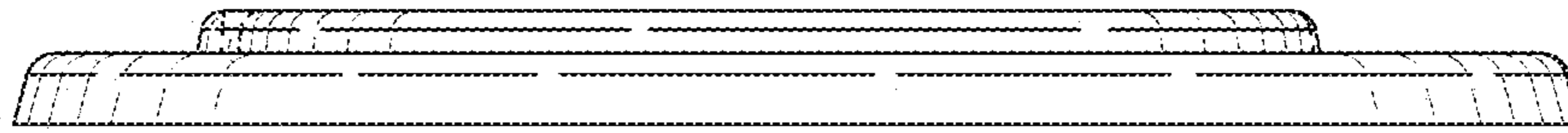

FIG. 61

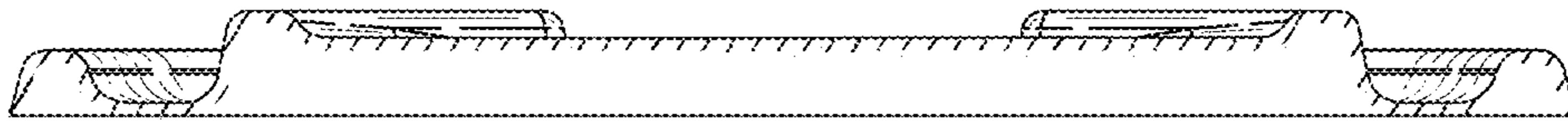

FIG. 62

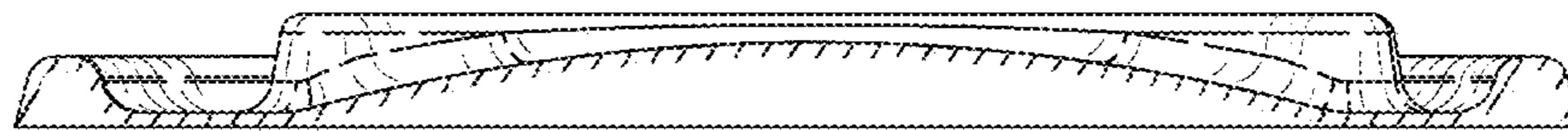

FIG. 63