



US00D899623S

(12) **United States Design Patent** (10) **Patent No.:** **US D899,623 S**
Mizutani et al. (45) **Date of Patent:** **** Oct. 20, 2020**

(54) **PIPETTE TIP FOR A LABORATORY INSTRUMENT**

(71) Applicant: **Beckman Coulter, Inc.**, Brea, CA (US)

(72) Inventors: **Takayuki Mizutani**, Edina, MN (US); **Shigeru Fujii**, Shizuoka (JP); **Kazuki Umebara**, Shizuoka (JP)

(73) Assignee: **Beckman Coulter, Inc.**, Brea, CA (US)

(**) Term: **15 Years**

(21) Appl. No.: **29/645,493**

(22) Filed: **Apr. 26, 2018**

(51) **LOC (12) Cl.** **24-02**

(52) **U.S. Cl.**

USPC **D24/222**

(58) **Field of Classification Search**

USPC D24/107, 108, 121, 133, 216, 222-230,
D24/232, 233; D9/523, 547, 549, 550,
D9/724, 732

(Continued)

(56) **References Cited**

U.S. PATENT DOCUMENTS

D198,263 S * 5/1964 Tieje D24/112
D204,352 S * 4/1966 Eizenberg D24/130

(Continued)

FOREIGN PATENT DOCUMENTS

CN 201730660435 * 12/2017
GB 1018976 * 4/1984
WO 2018081617 A2 5/2018

OTHER PUBLICATIONS

Standard Pipette Tips. Online, published date unknown. Retrieved on Jun. 28, 2019 from URL: <https://www.brandtech.com/product/standard-tips/>.*

(Continued)

Primary Examiner — Susan Bennett Hattan

Assistant Examiner — Omeed Agilee

(74) *Attorney, Agent, or Firm* — McAndrews, Held & Malloy, Ltd.

(57) **CLAIM**

The ornamental design for the pipette tip for a laboratory instrument, as shown and described.

DESCRIPTION

FIG. 1 is a perspective view of a first embodiment of a pipette tip for a laboratory instrument;

FIG. 2 is a front view thereof;

FIG. 3 is a rear view thereof;

FIG. 4 is a right side view thereof;

FIG. 5 is a left side view thereof;

FIG. 6 is a top view thereof;

FIG. 7 is a bottom view thereof;

FIG. 8 is a cross sectional view taken along line 8-8 shown in FIG. 6;

FIG. 9 is an enlarged sectional view taken along line 9-9 shown in FIG. 8;

FIG. 10 is an enlarged sectional view taken along line 10-10 shown in FIG. 8;

FIG. 11 is an enlarged sectional view taken along line 11-11 shown in FIG. 8;

FIG. 12 is a perspective view of a second embodiment of a pipette tip for a laboratory instrument;

FIG. 13 is a front view thereof;

FIG. 14 is a rear view thereof;

FIG. 15 is a right side view thereof;

FIG. 16 is a left side view thereof;

FIG. 17 is a top view thereof;

FIG. 18 is a bottom view thereof;

FIG. 19 is a cross sectional view taken along line 19-19 shown in FIG. 17;

FIG. 20 is an enlarged sectional view taken along line 20-20 shown in FIG. 19;

FIG. 21 is an enlarged sectional view taken along line 21-21 shown in FIG. 19;

(Continued)

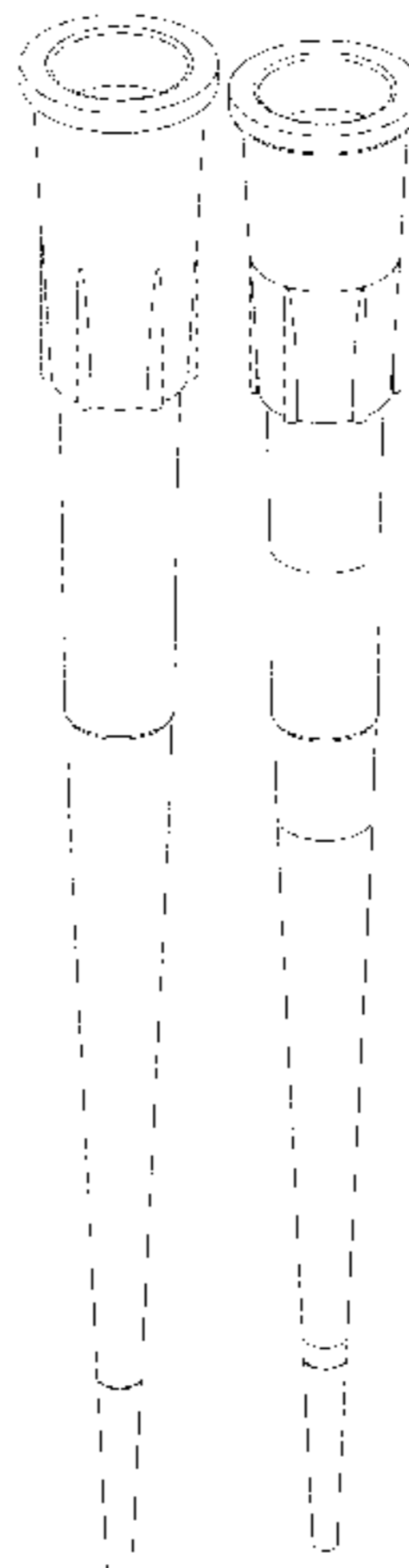

FIG. 22 is an enlarged sectional view taken along line 22-22 shown in FIG. 19;
 FIG. 23 is a perspective view of a third embodiment of a pipette tip for a laboratory instrument;
 FIG. 24 is a front view thereof;
 FIG. 25 is a rear view thereof;
 FIG. 26 is a right side view thereof;
 FIG. 27 is a left side view thereof;
 FIG. 28 is a top view thereof;
 FIG. 29 is a bottom view thereof;
 FIG. 30 is a cross sectional view taken along line 30-30 shown in FIG. 28;
 FIG. 31 is an enlarged sectional view taken along line 31-31 shown in FIG. 30;
 FIG. 32 is an enlarged sectional view taken along line 32-32 shown in FIG. 30;
 FIG. 33 is an enlarged sectional view taken along line 33-33 shown in FIG. 30;
 FIG. 34 is a perspective view of a fourth embodiment of a pipette tip for a laboratory instrument;
 FIG. 35 is a front view thereof;
 FIG. 36 is a rear view thereof;
 FIG. 37 is a right side view thereof;
 FIG. 38 is a left side view thereof;
 FIG. 39 is a top view thereof;
 FIG. 40 is a bottom view thereof;
 FIG. 41 is a cross sectional view taken along line 41-41 shown in FIG. 39;
 FIG. 42 is an enlarged sectional view taken along line 42-42 shown in FIG. 41;
 FIG. 43 is an enlarged sectional view taken along line 43-43 shown in FIG. 41;
 FIG. 44 is a perspective view of a fifth embodiment of a pipette tip for a laboratory instrument;
 FIG. 45 is a front view thereof;
 FIG. 46 is a rear view thereof;
 FIG. 47 is a right side view thereof;
 FIG. 48 is a left side view thereof;
 FIG. 49 is a top view thereof;
 FIG. 50 is a bottom view thereof;
 FIG. 51 is a cross sectional view taken along line 51-51 shown in FIG. 49;
 FIG. 52 is an enlarged sectional view taken along line 52-52 shown in FIG. 51; and,
 FIG. 53 is an enlarged sectional view taken along line 53-53 shown in FIG. 51.
 The dot-dash lines in the drawings are sectional indicators that form no part of the claimed design.

1 Claim, 25 Drawing Sheets

(58) **Field of Classification Search**

CPC B01F 13/0025; B01J 2219/00292; B01J 2220/64; B01L 3/14; B01L 3/021; B01L 3/508; B01L 3/52-523

See application file for complete search history.

(56)

References Cited

U.S. PATENT DOCUMENTS

D255,601	S	6/1980	De Vaughn	
D256,052	S *	7/1980	De Vaughn	D24/112
D274,652	S	7/1984	DeVaughn	
D286,570	S *	11/1986	Williams	D24/112
4,707,337	A *	11/1987	Jeffs	B01L 3/0275 422/525
D297,054	S	8/1988	Williams	
D384,418	S	9/1997	Torti et al.	
5,851,491	A *	12/1998	Moulton	B01L 3/0275 422/535
D414,562	S *	9/1999	Tajima	D24/222
D416,625	S	11/1999	Torti et al.	
D437,940	S *	2/2001	Rainin	D24/222
D438,981	S *	3/2001	Rainin	D24/222
D439,986	S	4/2001	Petrek	
D441,458	S	5/2001	Petrek	
D446,864	S *	8/2001	Petrek	D24/222
D448,853	S	10/2001	Rainin et al.	
D461,904	S	8/2002	Petrek	
D465,853	S	11/2002	Petersen	
D468,024	S	12/2002	Petrek	
D468,440	S	1/2003	Petrek	
D468,832	S *	1/2003	Petrek	D24/222
D487,593	S	3/2004	Sarna	
D560,815	S	1/2008	Tajima	
D601,712	S	10/2009	Tajima	
D663,042	S *	7/2012	Motadel	D24/222
D679,826	S	4/2013	Ziegmann	
D679,828	S *	4/2013	Motadel	D24/222
D680,226	S *	4/2013	Motadel	D24/222
D687,562	S *	8/2013	Motadel	B01L 3/0275 D24/222
8,524,170	B2	9/2013	Petrek	
D703,344	S *	4/2014	Herbst	D24/222
8,828,331	B2	9/2014	Tajima	
9,156,030	B2 *	10/2015	Beese	B01L 3/021
9,346,045	B2	5/2016	Blumentritt et al.	
D788,314	S *	5/2017	Ando	D24/222
D841,182	S	2/2019	Mizutani	
D847,367	S *	4/2019	Trump	D24/222
2002/0009809	A1 *	1/2002	Brewer	B01L 3/0275 436/66
2006/0171851	A1	8/2006	Motadel	
2007/0231215	A1	10/2007	Mototsu et al.	
2011/0036185	A1	2/2011	Petrek et al.	
2011/0183433	A1	7/2011	Motadel et al.	
2011/0259443	A1	10/2011	Preschutti et al.	

OTHER PUBLICATIONS

Mizutani, Takayuki et al., Design U.S. Appl. No. 29/680,748 for Pipette Tip for a Laboratory Instrument, filed Feb. 19, 2019. Japanese Patent Office; Office Action for Application No. 2017-009426 dated Aug. 30, 2017; 3 pages.
 Japanese Patent Office Design Division Known Document No. HJ23077729; Internet Confirmation date of publication (publicly-known date): Mar. 5, 2012 Receipt date: Mar. 9, 2012; Publisher: VWR Scientific Products; [https:// media.vwr.com/stibo/low_res/4672085.jp](https://media.vwr.com/stibo/low_res/4672085.jp); 1 page.
 Cientifica Vela Quin Sa De CV; Puntas para micropipeta. [online] Retrieved Jul. 5, 2018 from URL: <https://www.velaquin.com.mx/products/puntas-para-micropipeta?variant=31262261313>; 10 pages.
 Thermofisher Scientific; Finntip Filtered Pipette Tips; [online] Retrieved Jun. 21, 2018 from URL: <https://www.thermofisher.com/order/catalog/product/94052000>; 7 pages.

* cited by examiner

FIG. 1

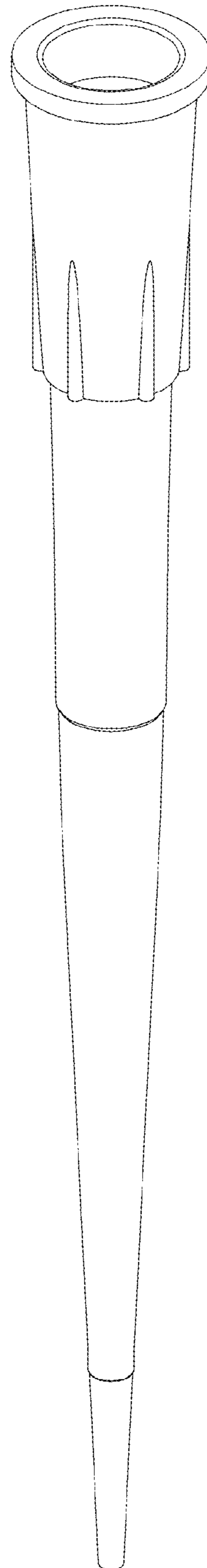

FIG. 2

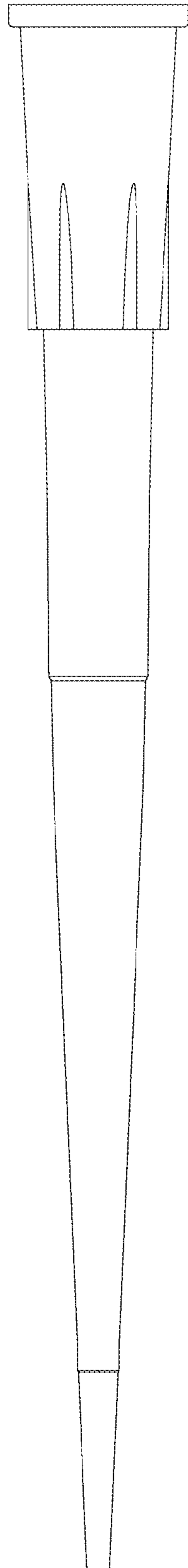

FIG. 3

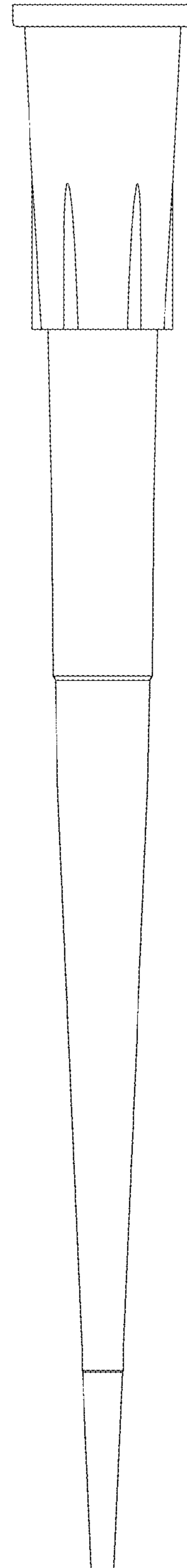

FIG. 4

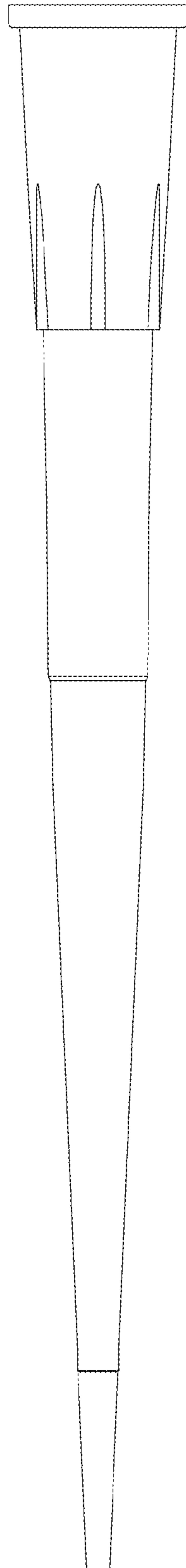

FIG. 5

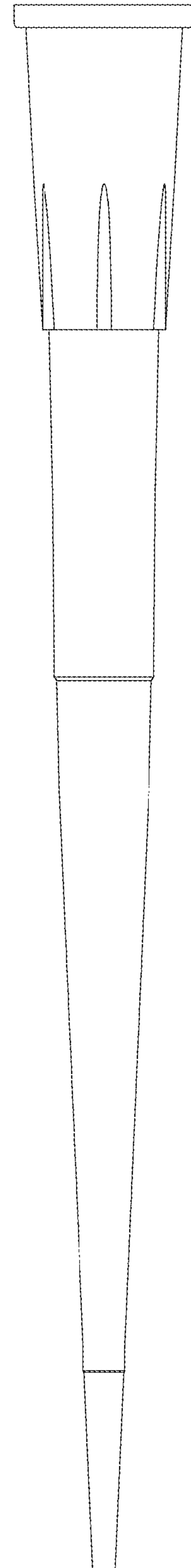

FIG. 6

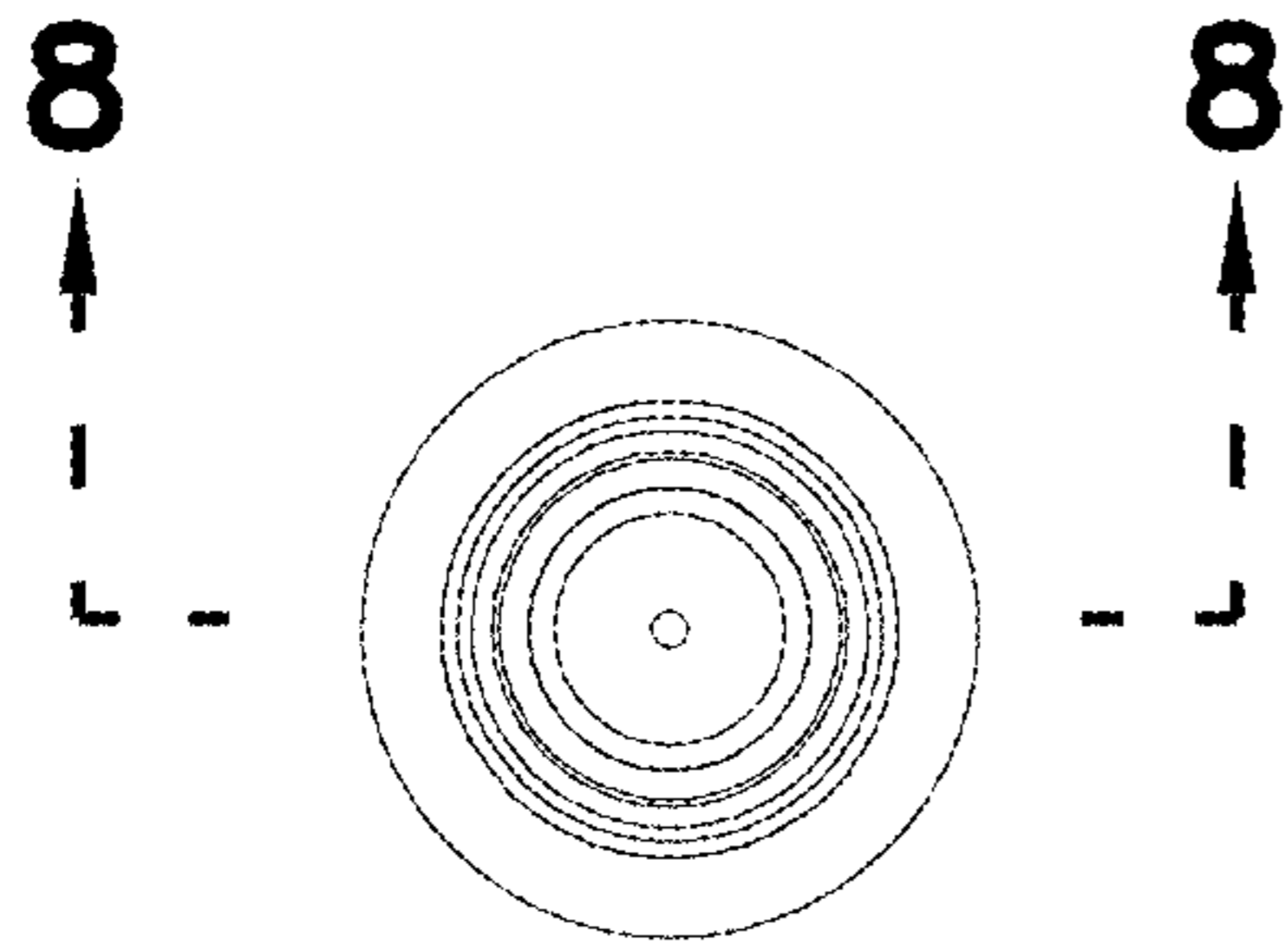

FIG. 8

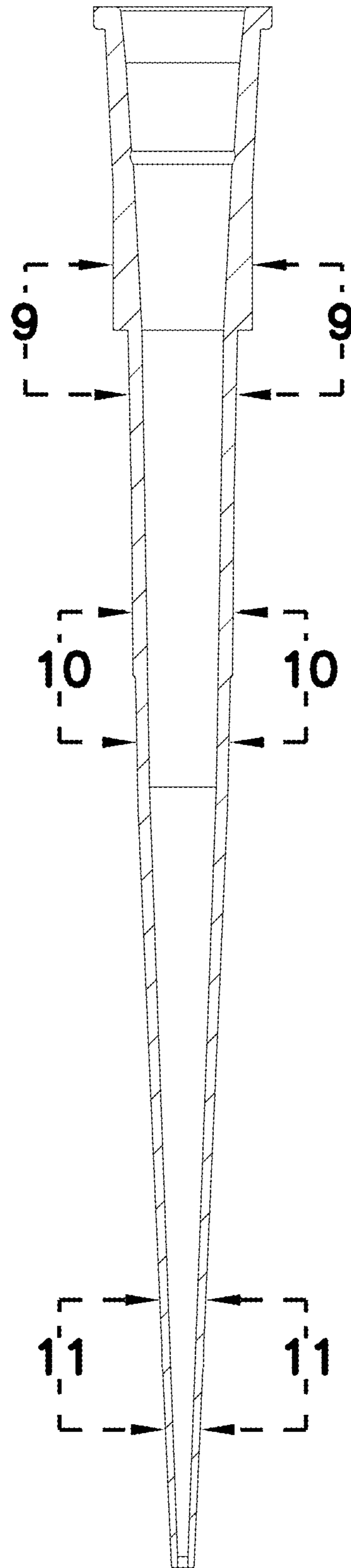

FIG. 7

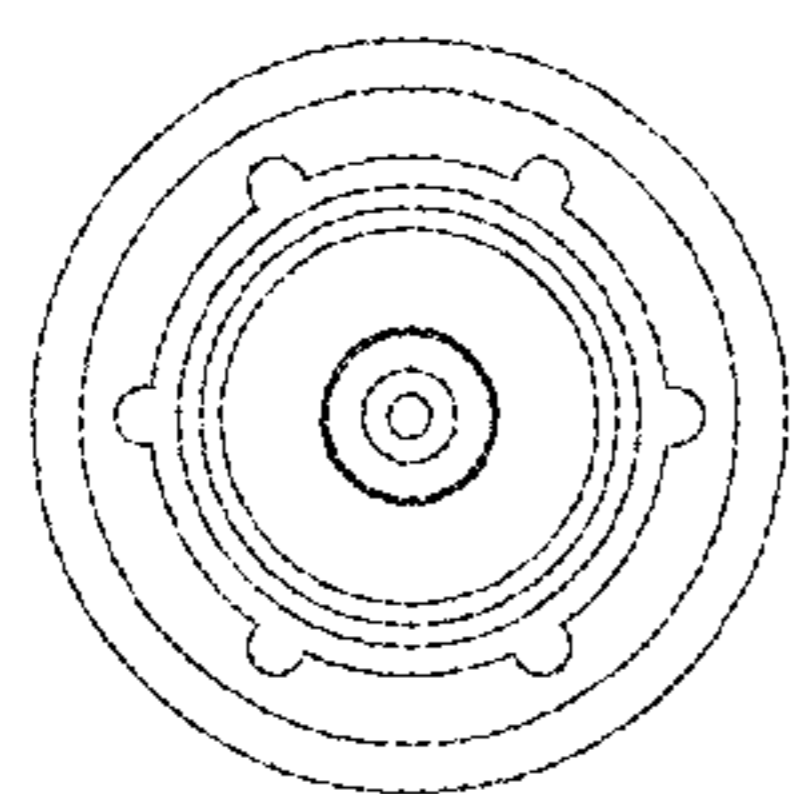

FIG. 9

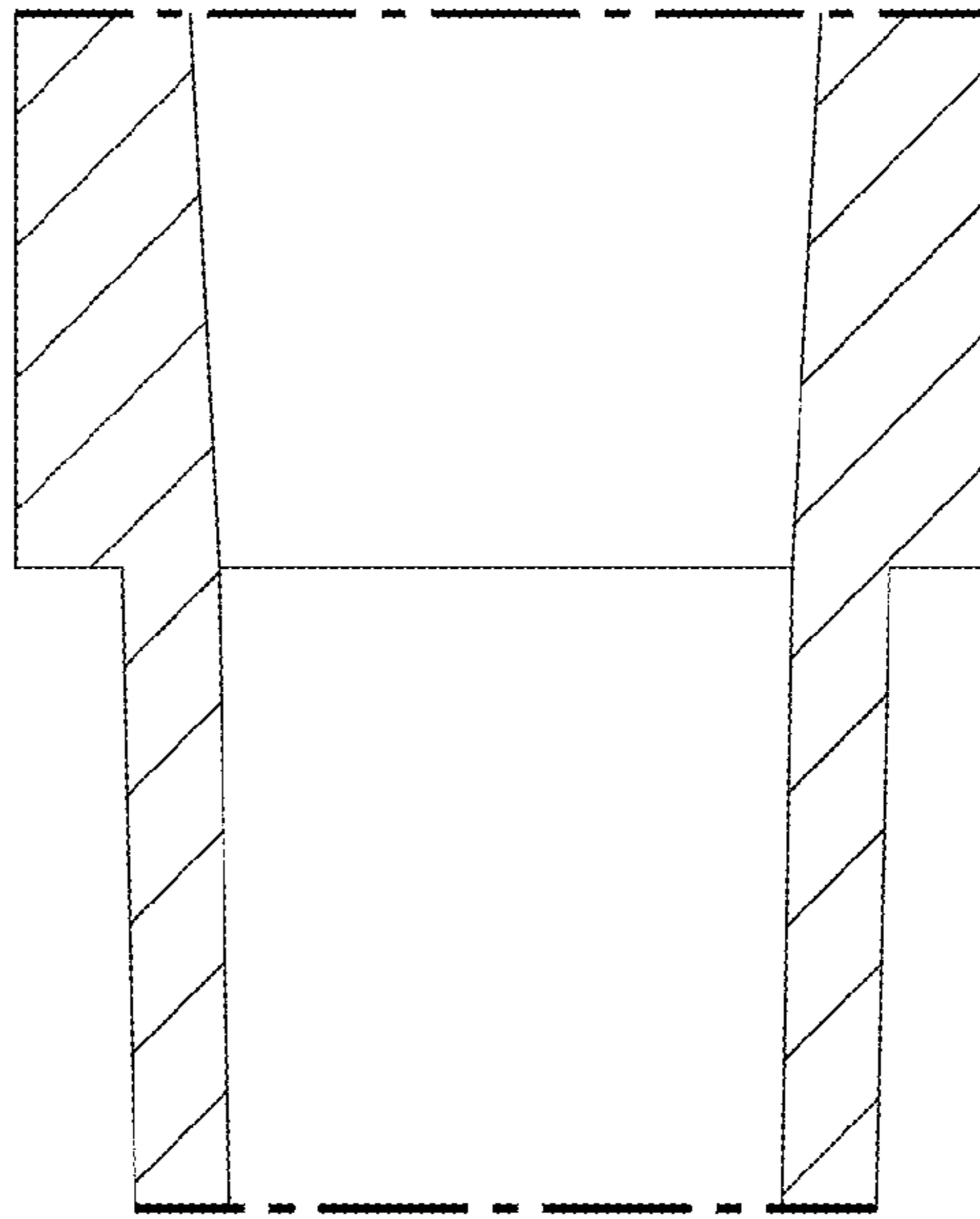

FIG. 10

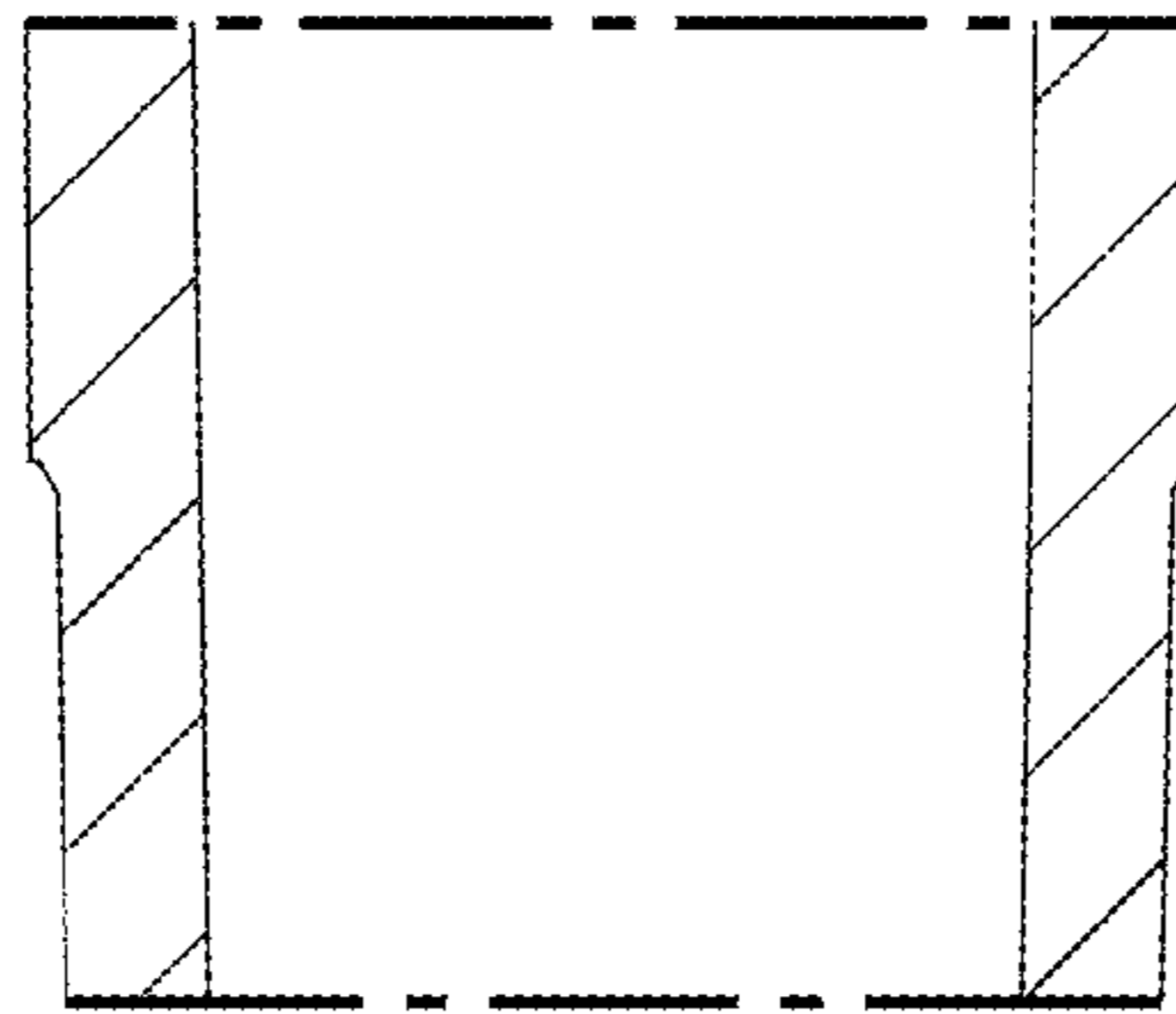

FIG. 11

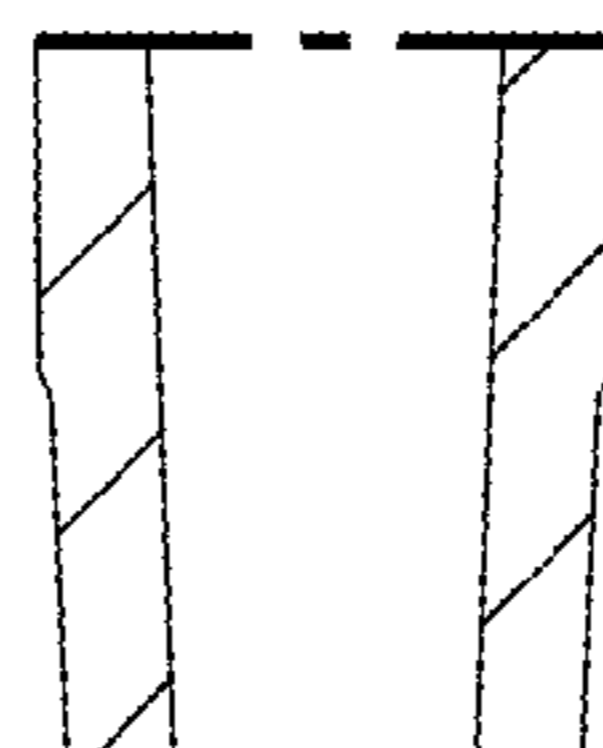

FIG. 12

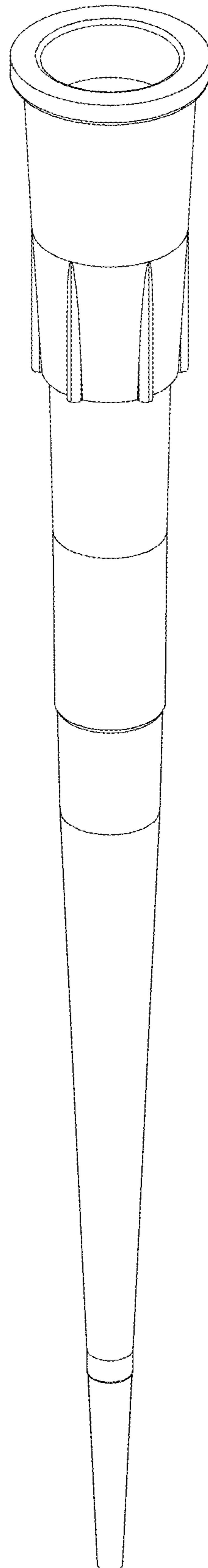

FIG. 13

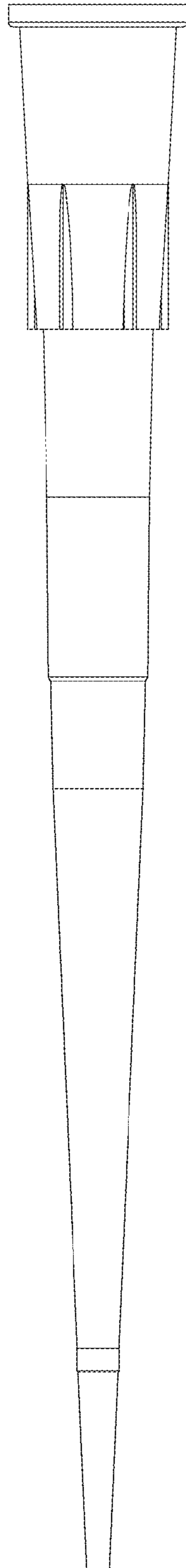

FIG. 14

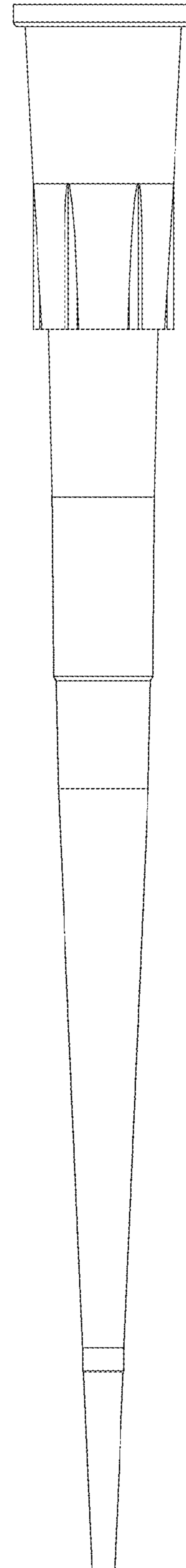

FIG. 15

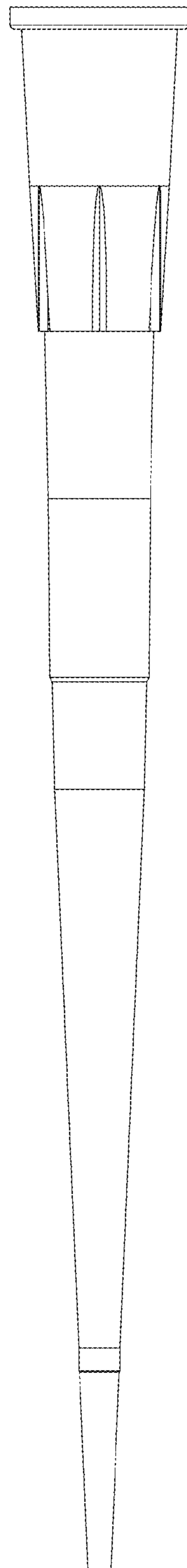

FIG. 16

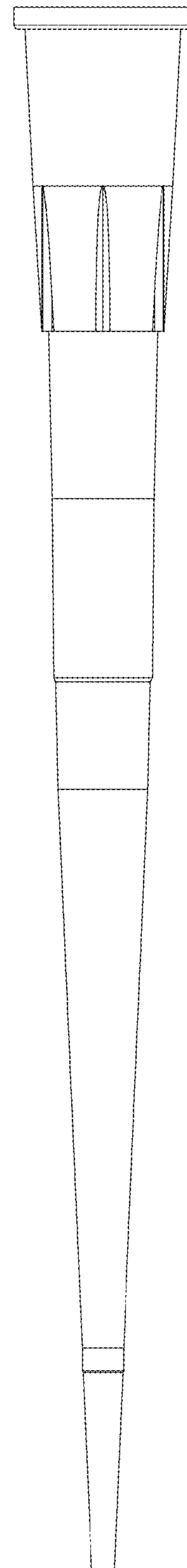

FIG. 17

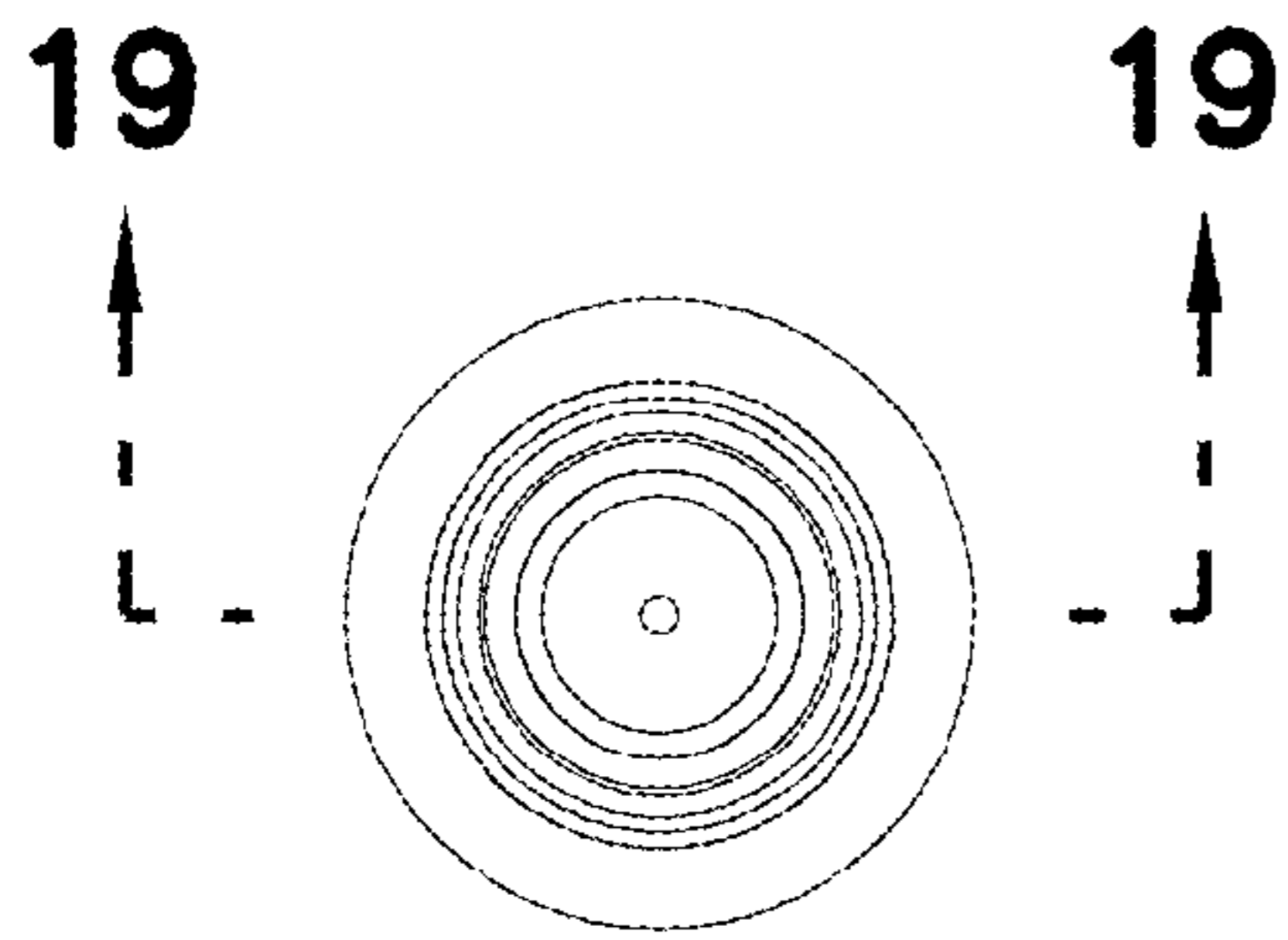

FIG. 19

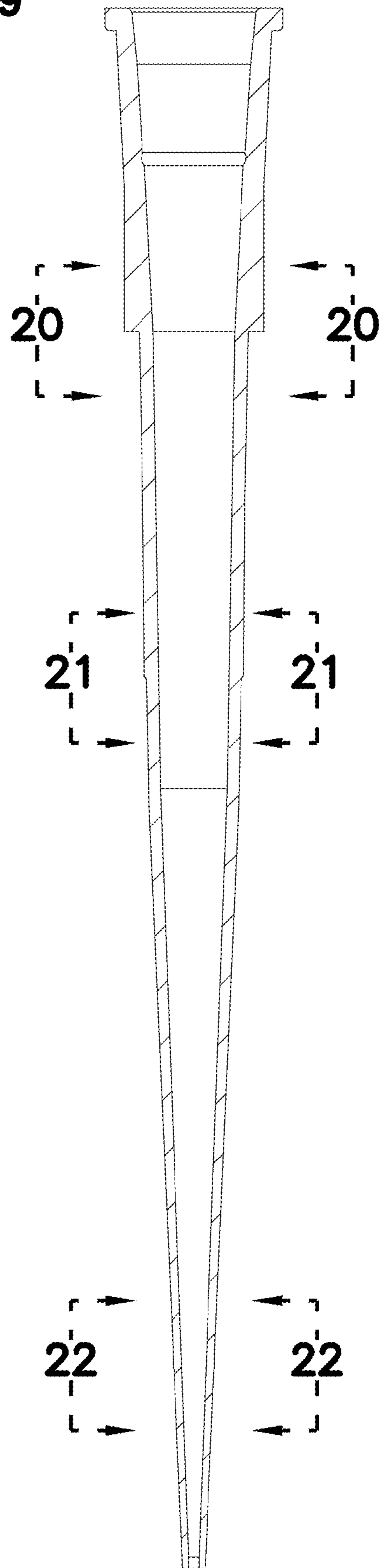

FIG. 18

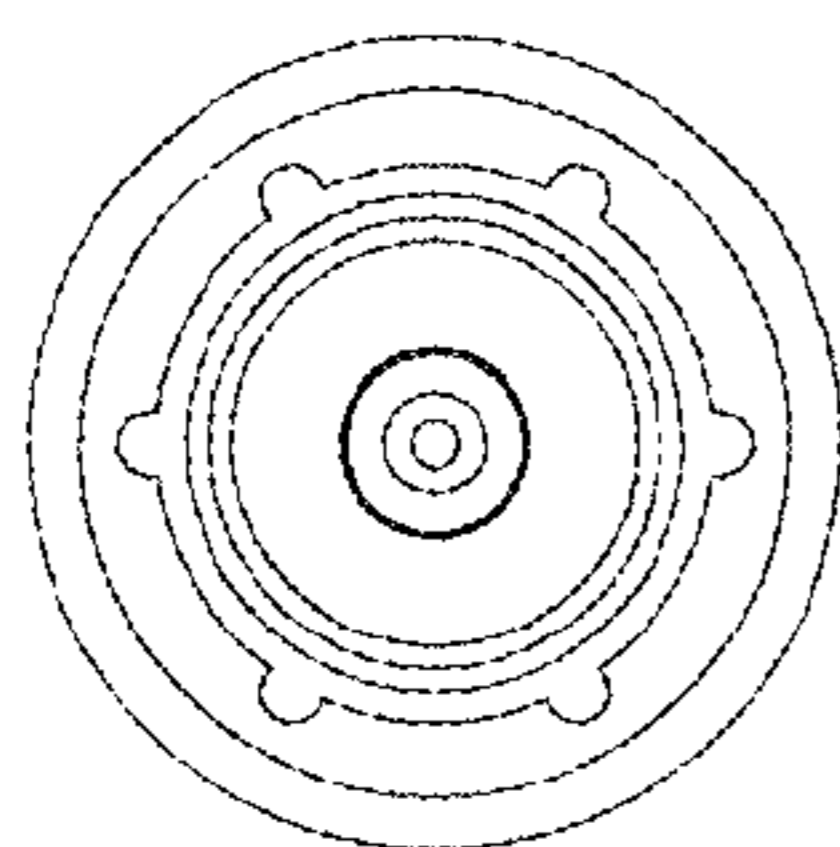

FIG. 20

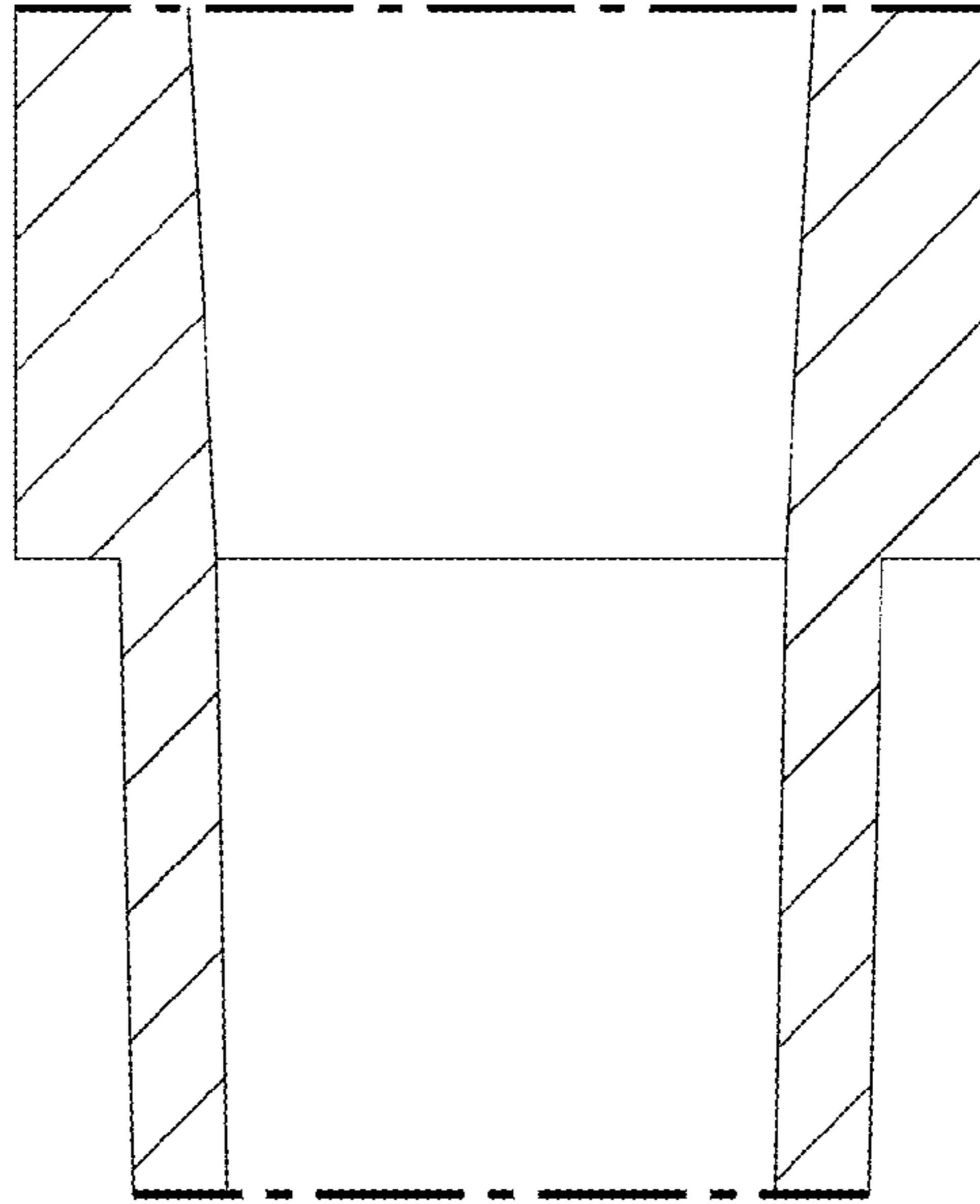

FIG. 21

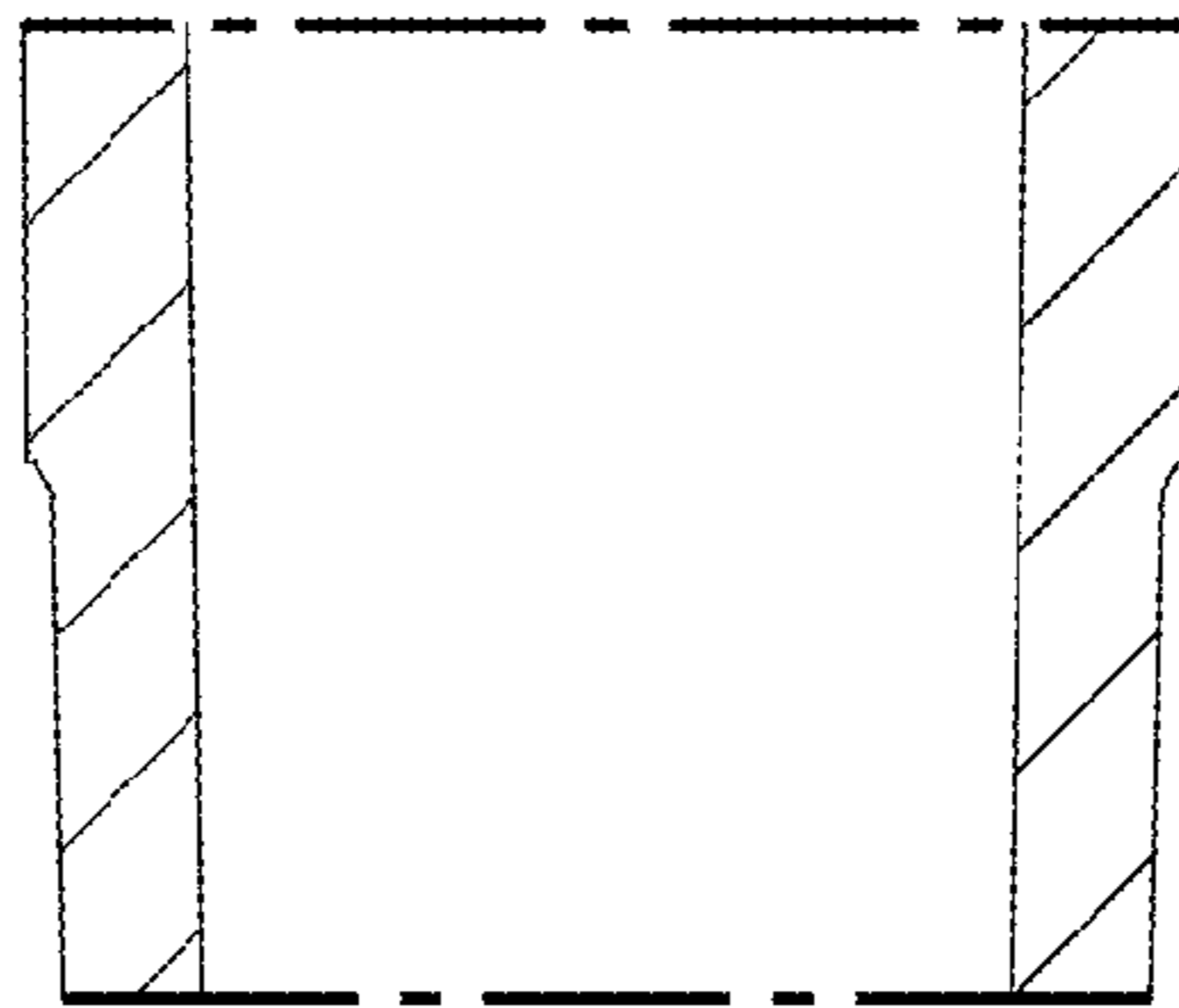

FIG. 22

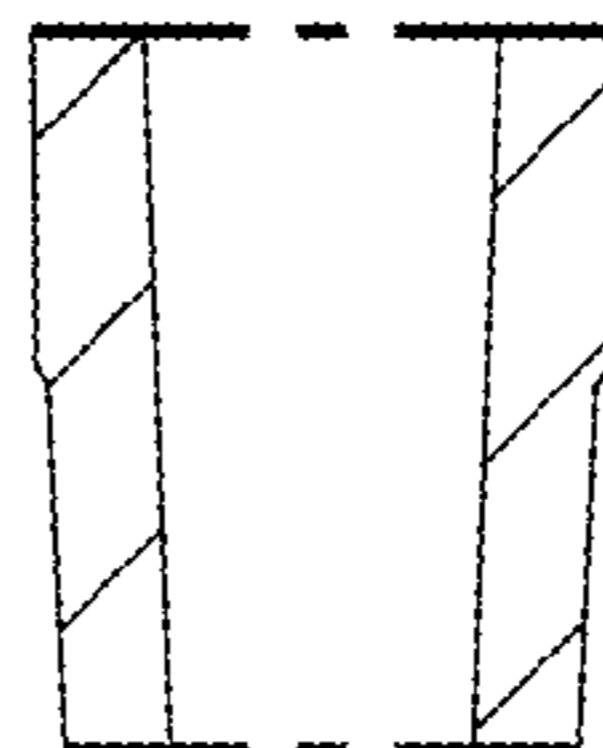

FIG. 23

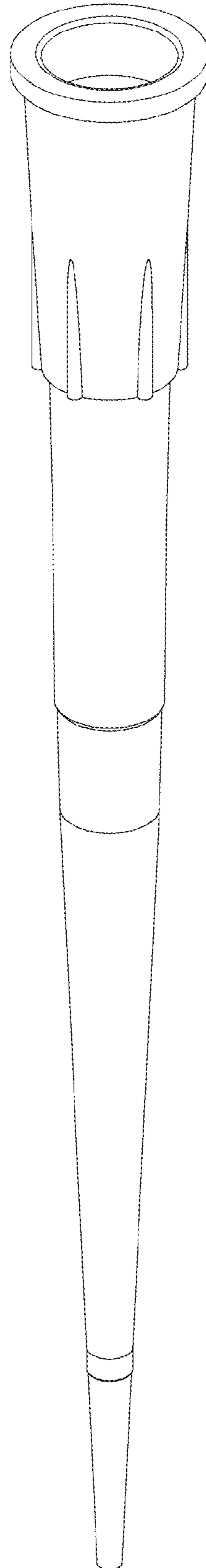

FIG. 24

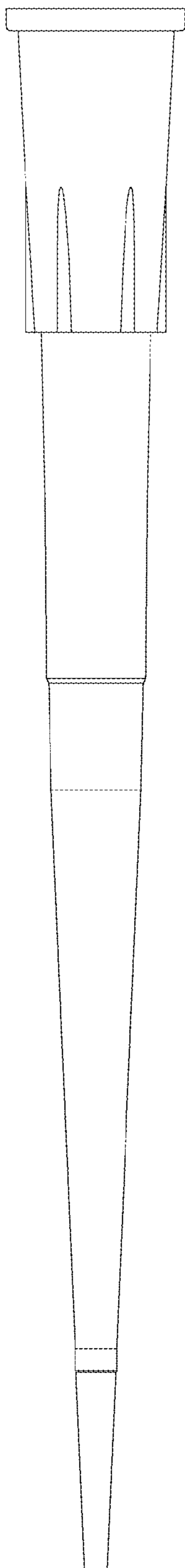

FIG. 25

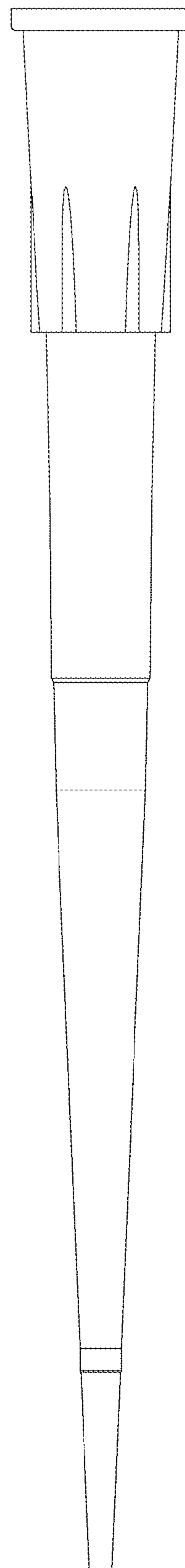

FIG. 26

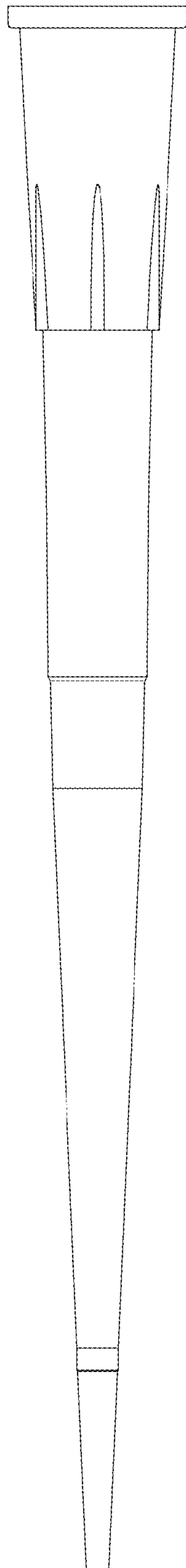

FIG. 27

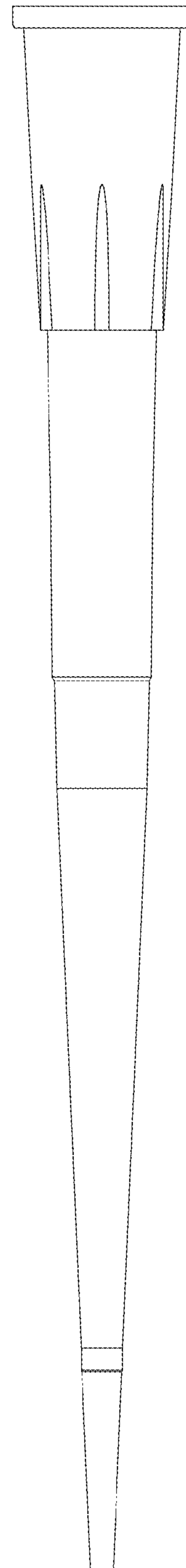

FIG. 28

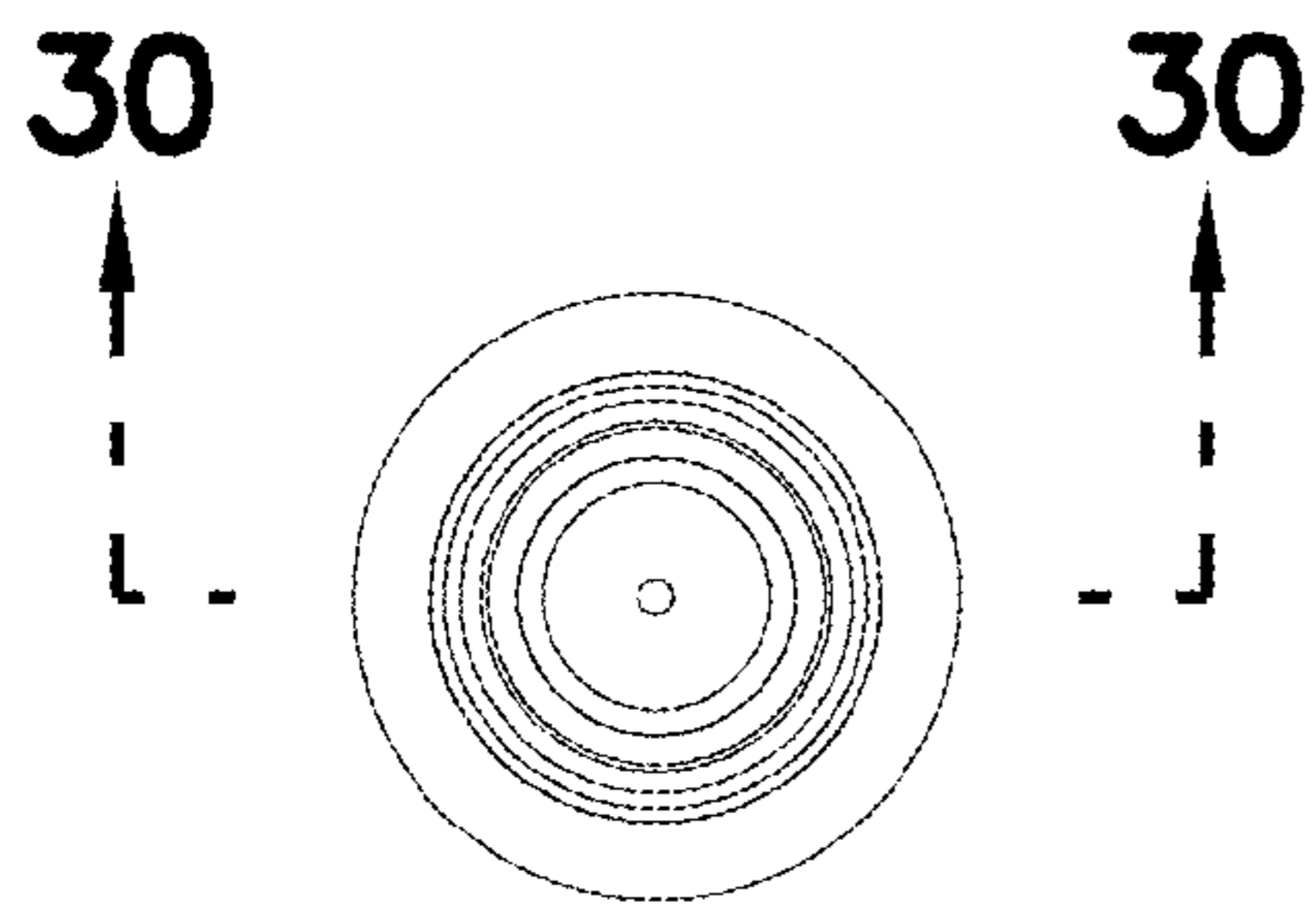

FIG. 30

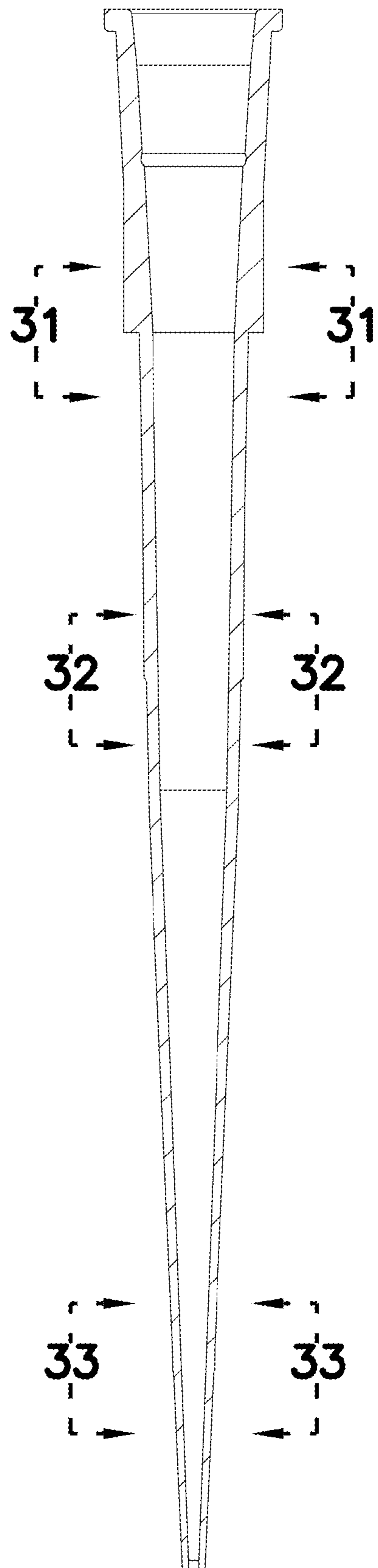

FIG. 29

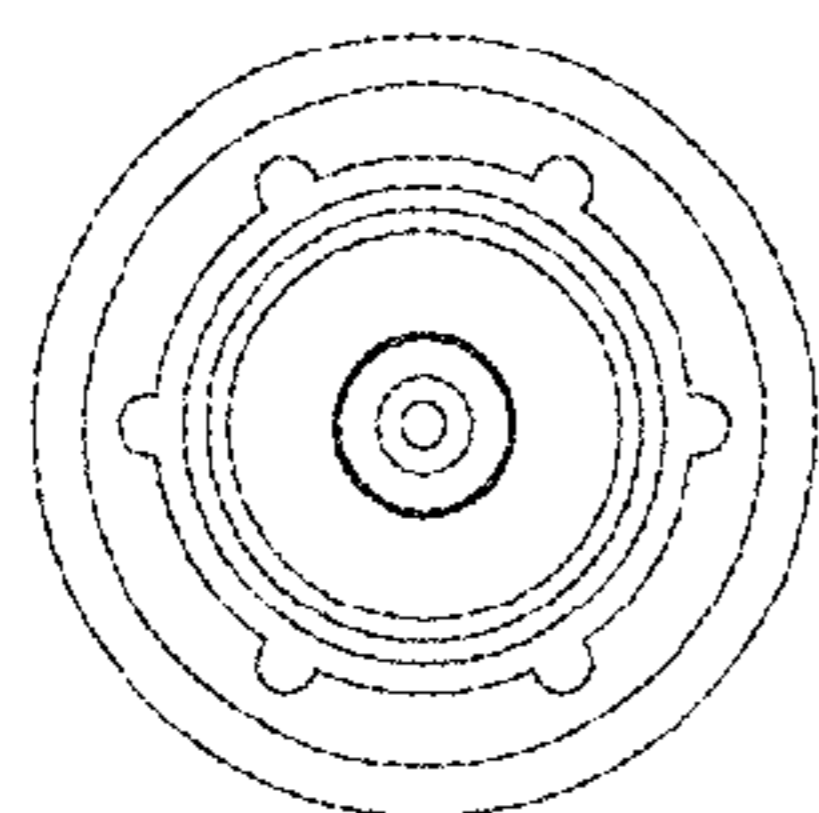

FIG. 31

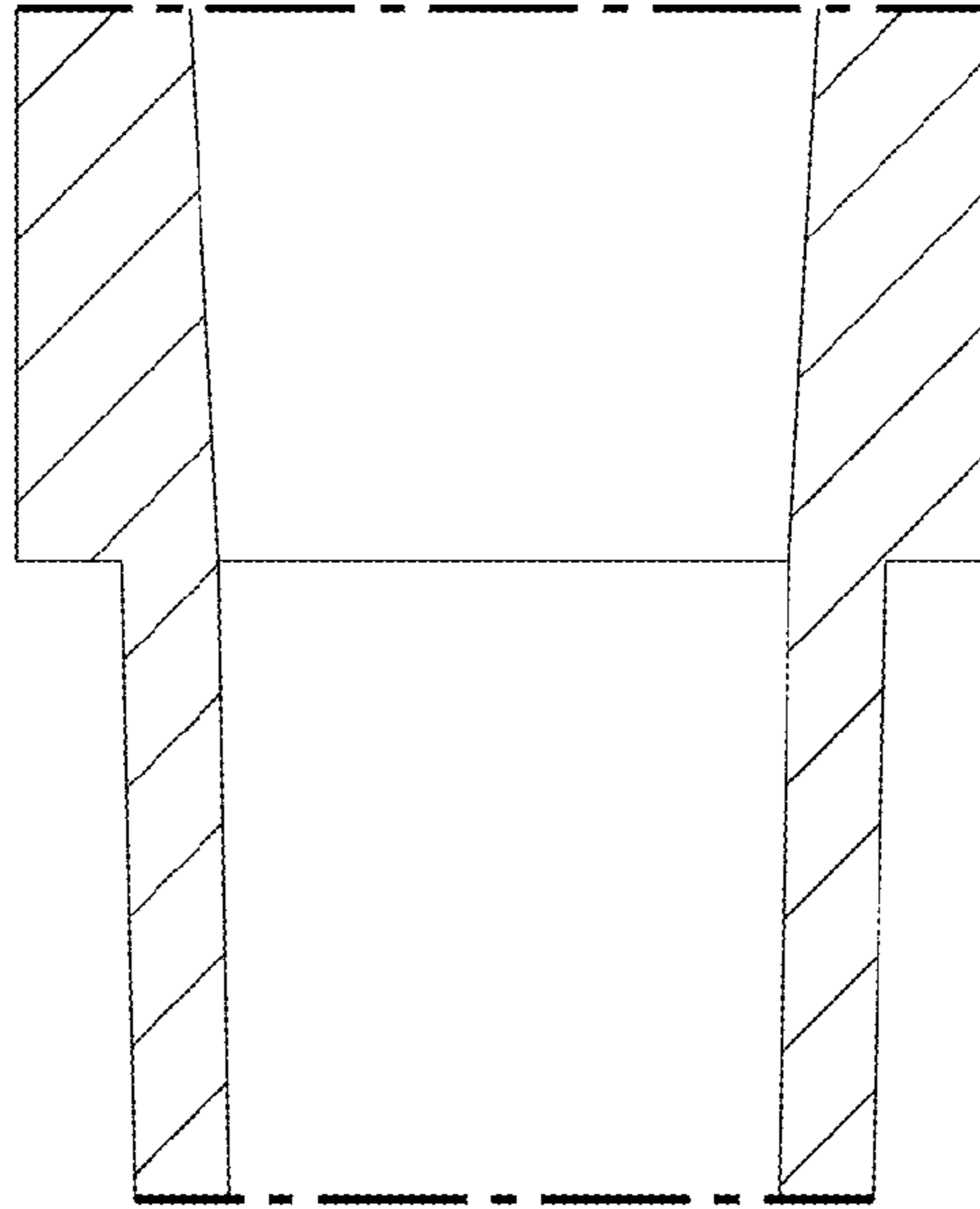

FIG. 32

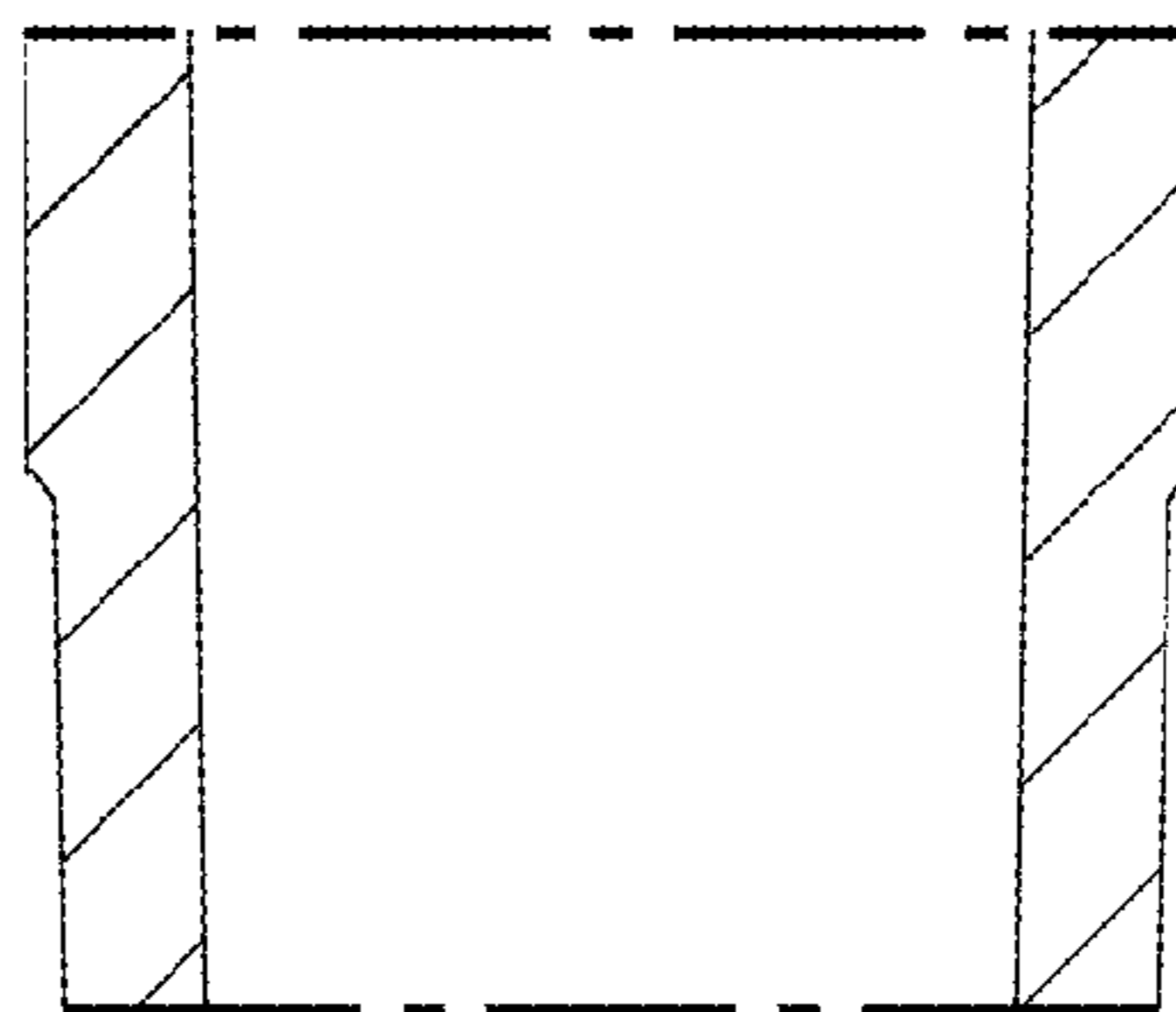

FIG. 33

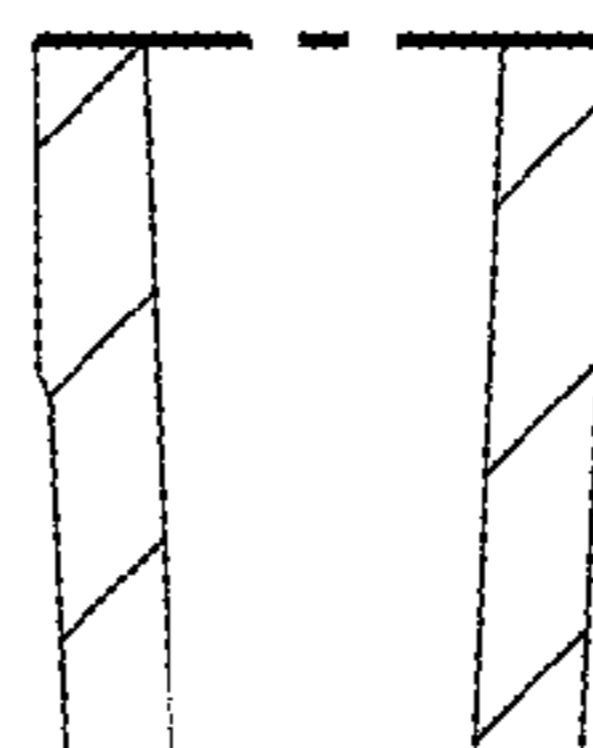

FIG. 34

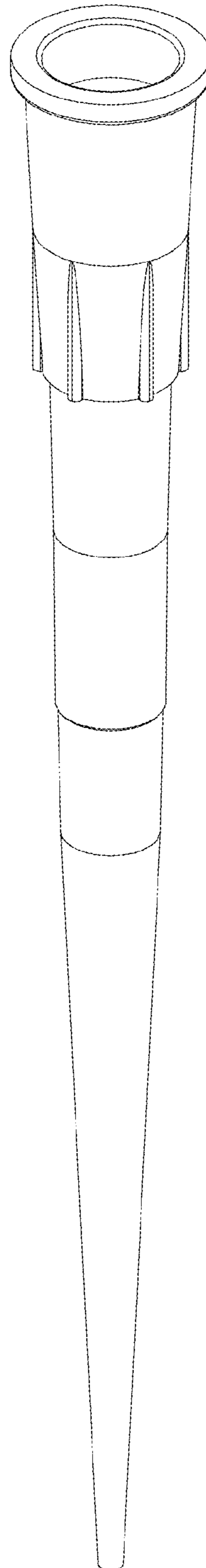

FIG. 35

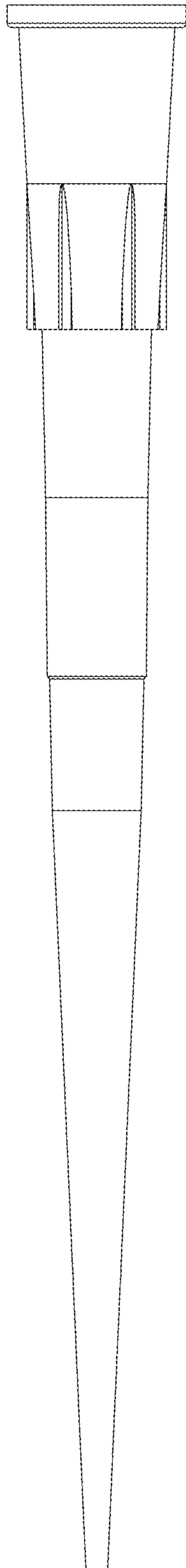

FIG. 36

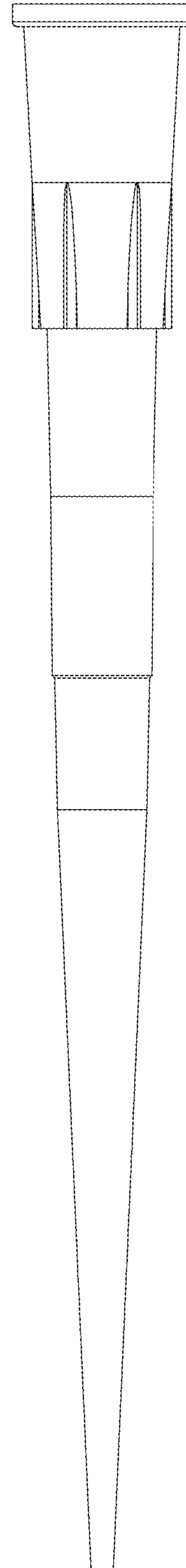

FIG. 37

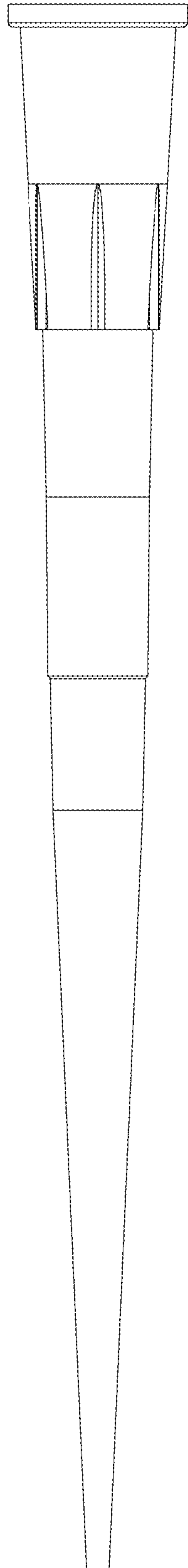

FIG. 38

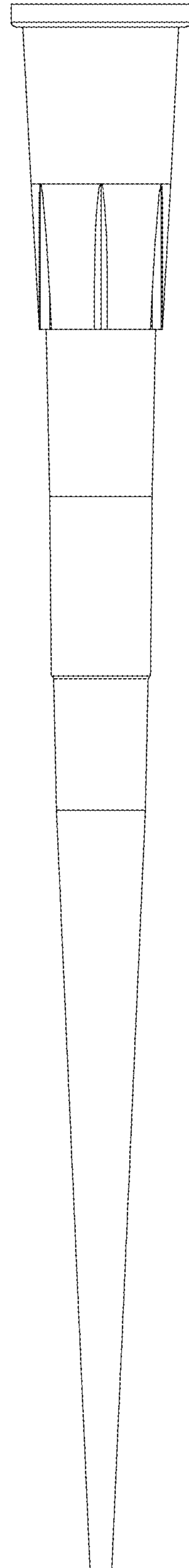

FIG. 39

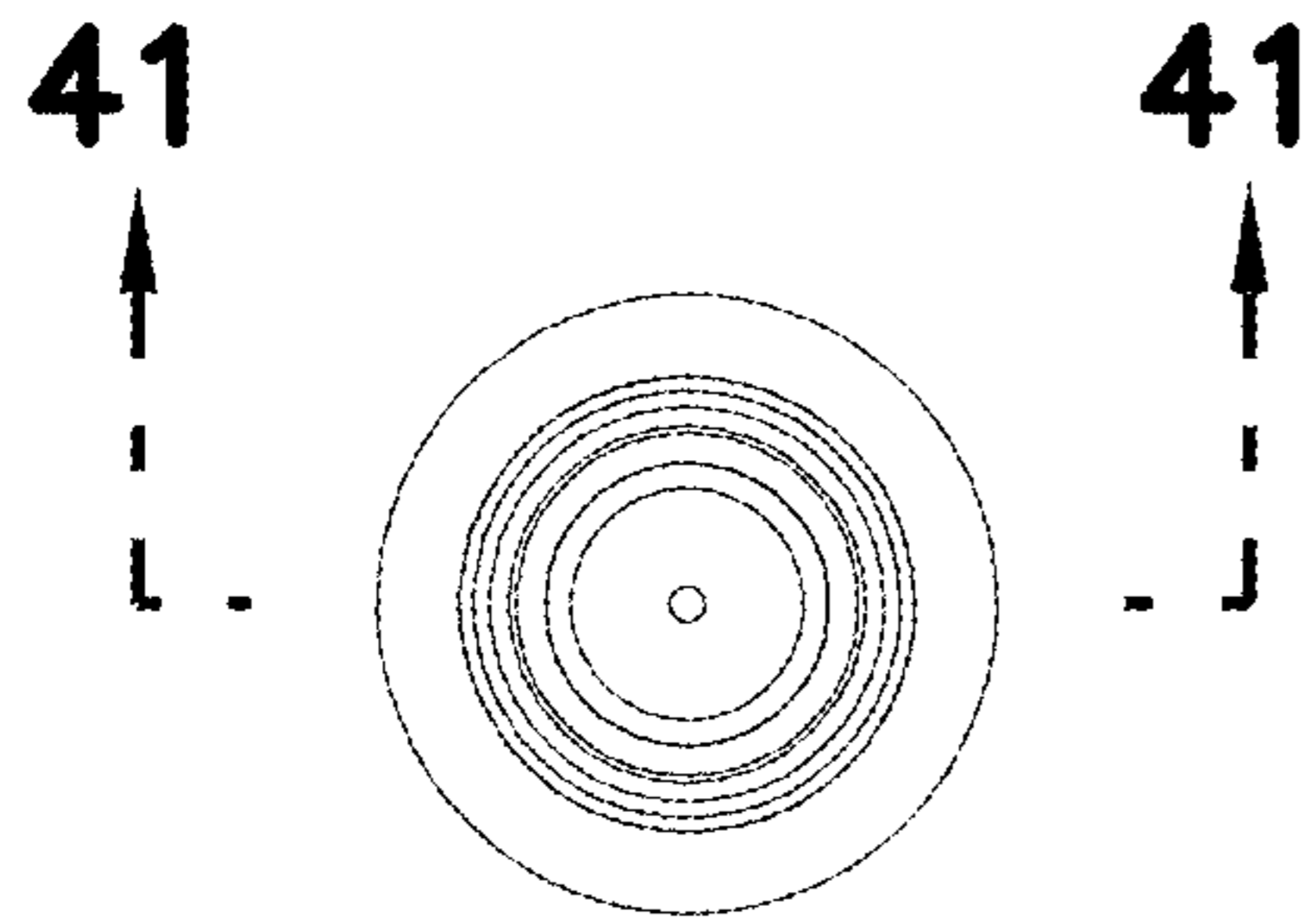

FIG. 41

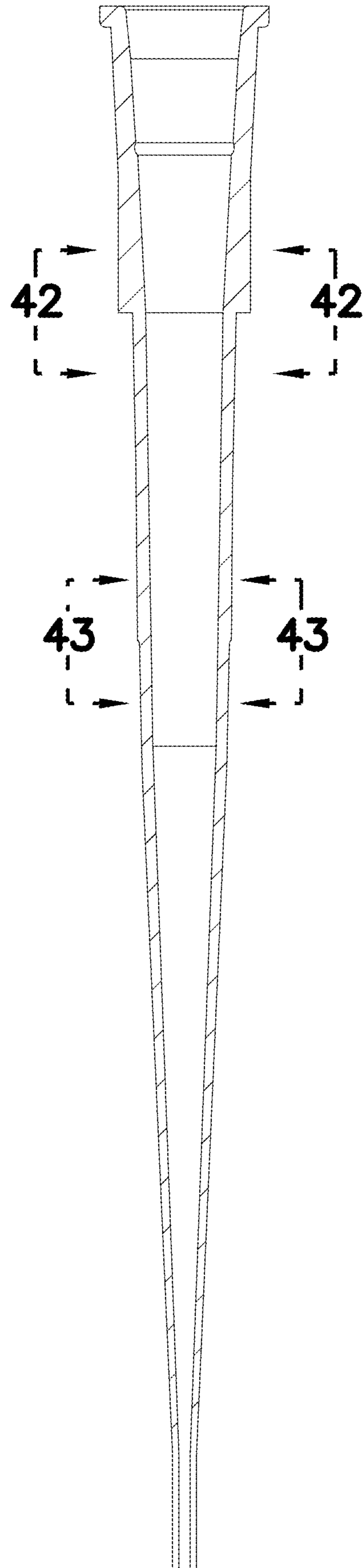

FIG. 40

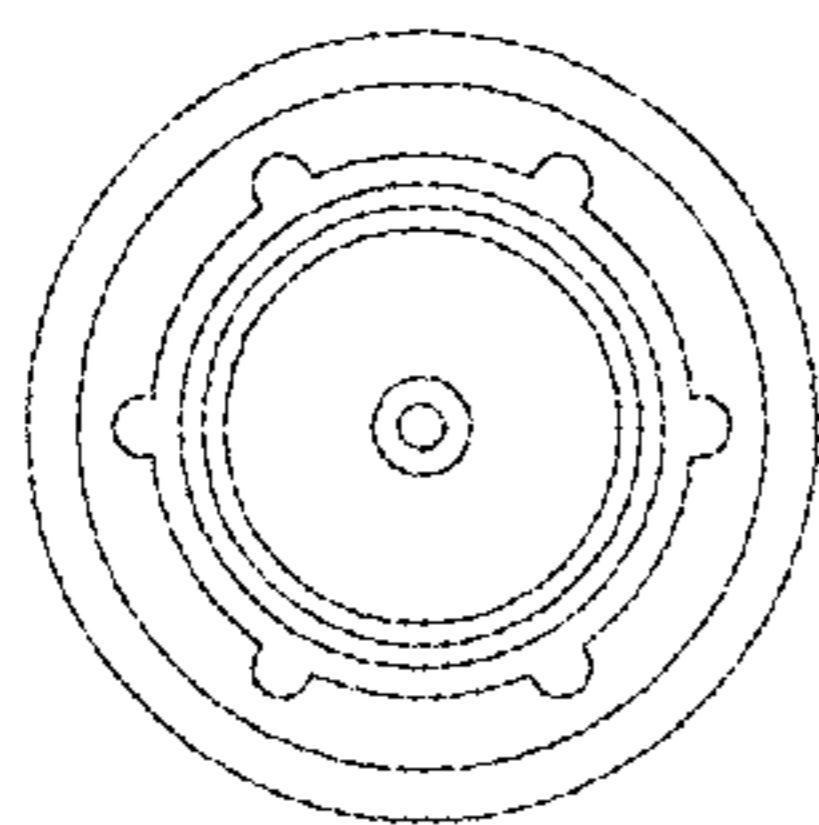

FIG. 42

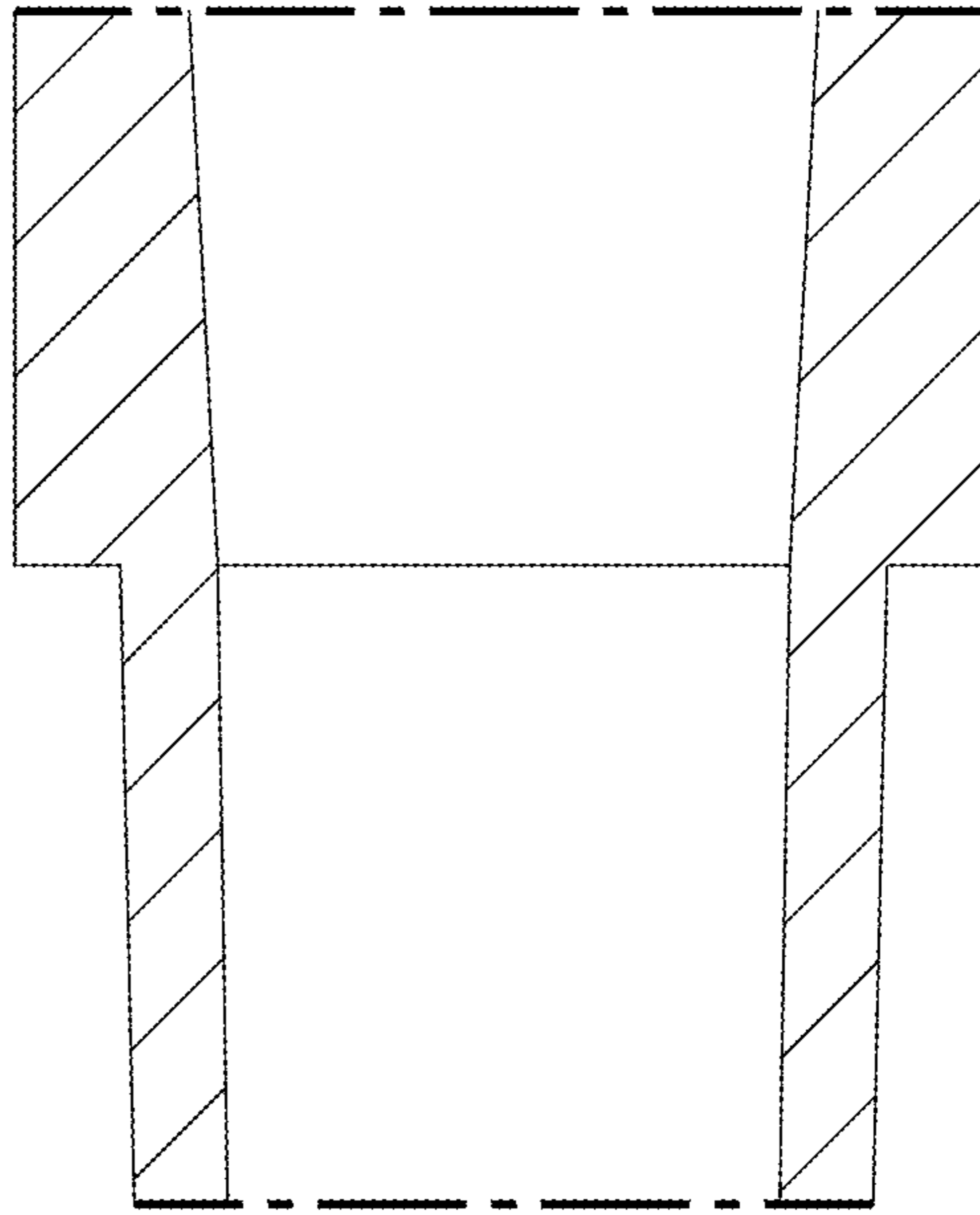

FIG. 43

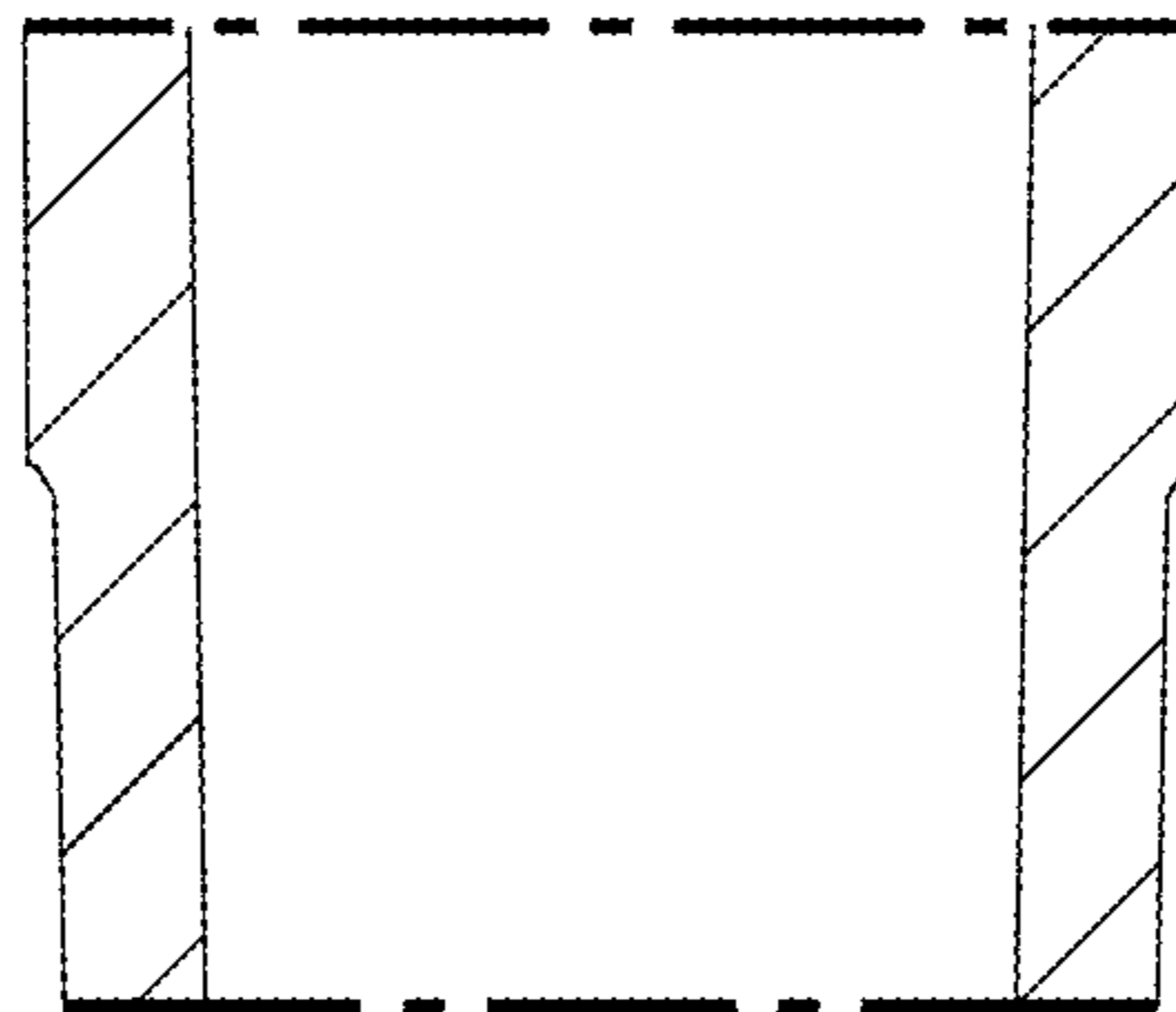

FIG. 44

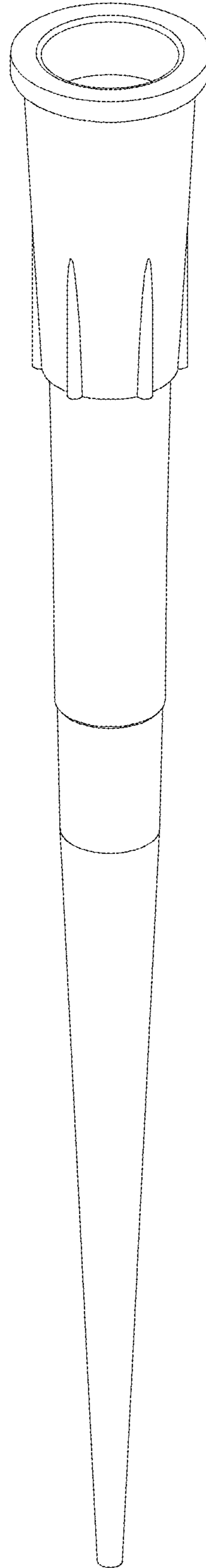

FIG. 45

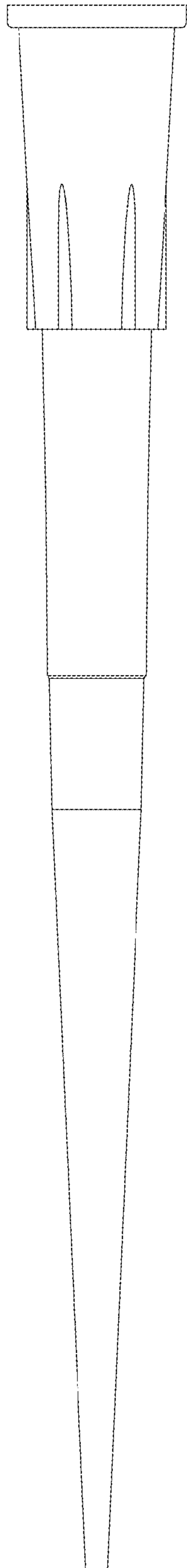

FIG. 46

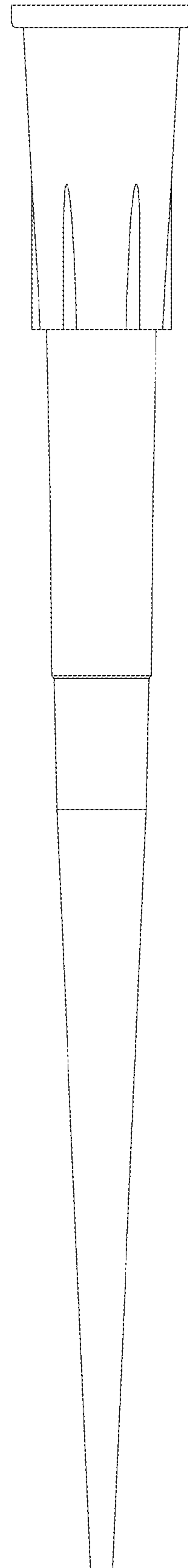

FIG. 47

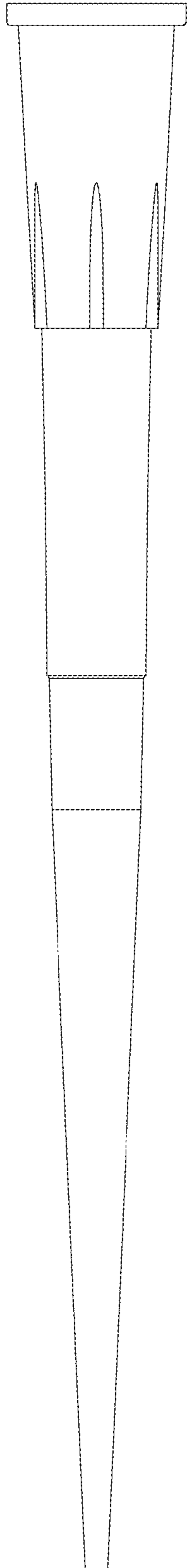

FIG. 48

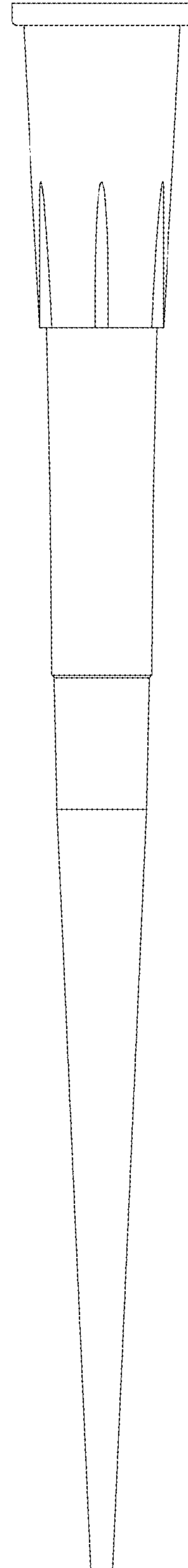

FIG. 49

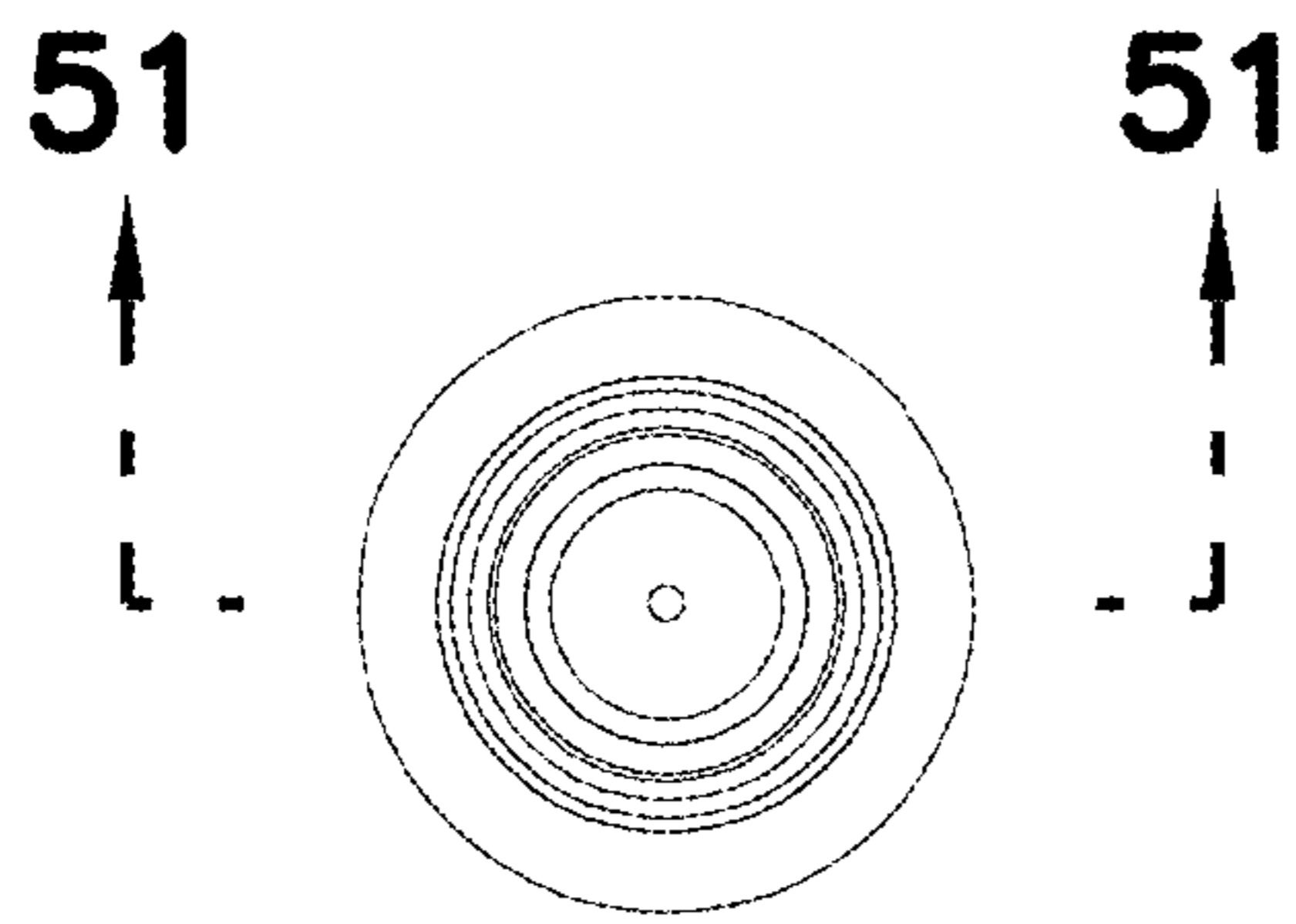

FIG. 51

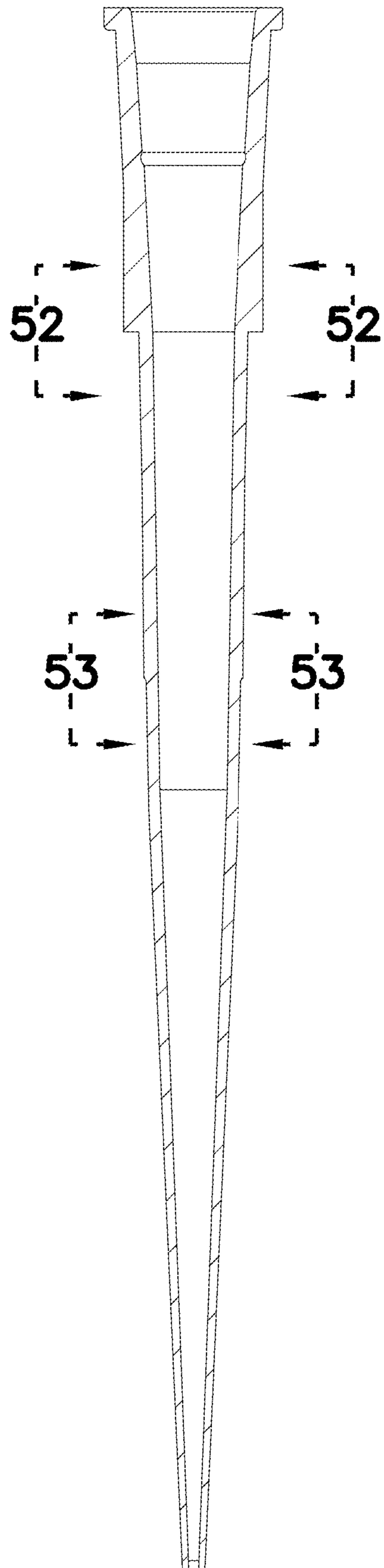

FIG. 50

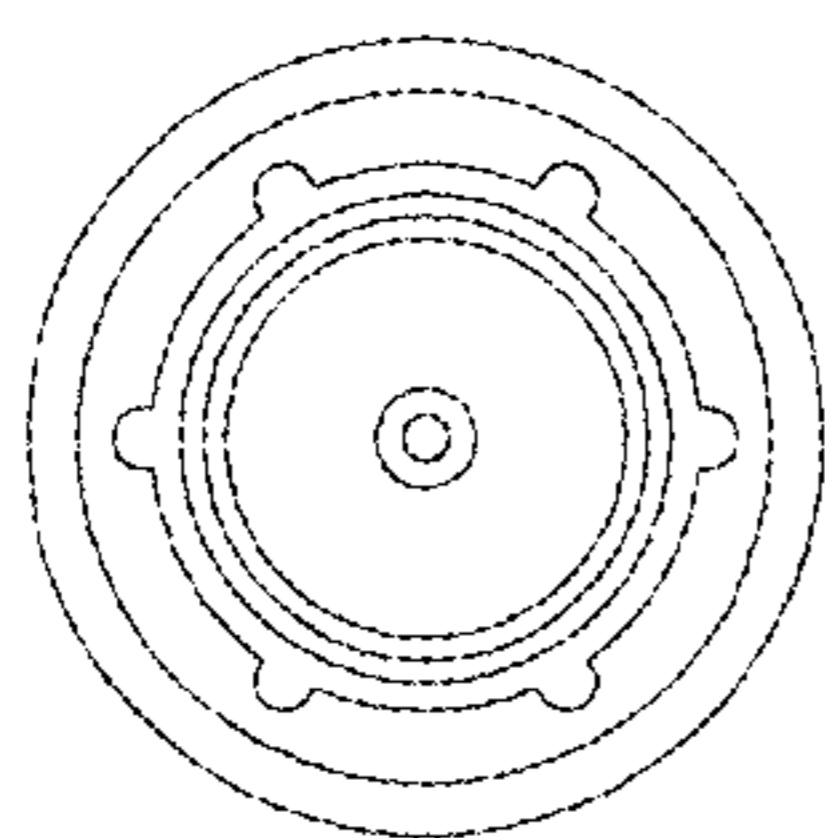

FIG. 52

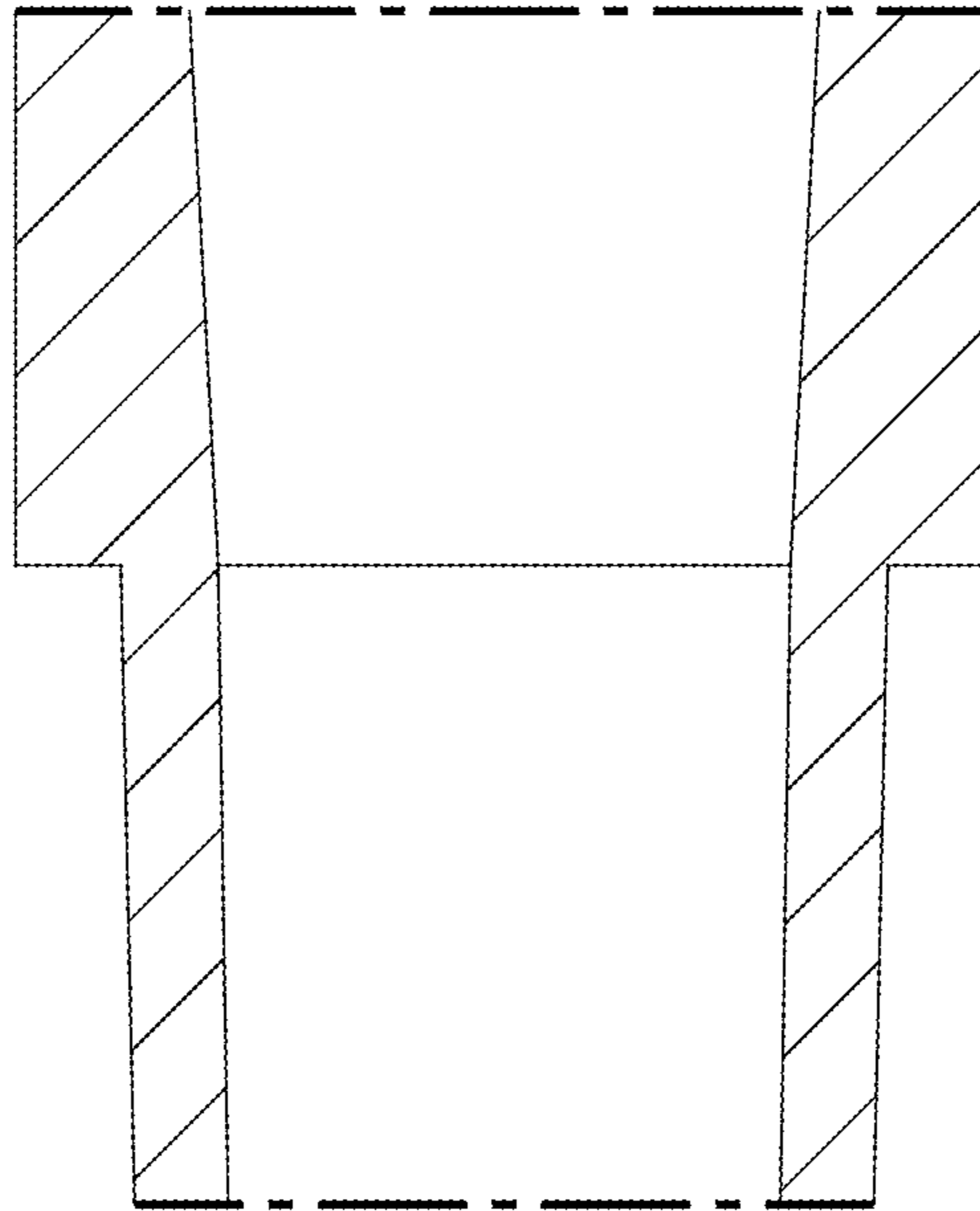

FIG. 53

