



US00D899546S

(12) **United States Design Patent** (10) **Patent No.:** **US D899,546 S**
Peterson (45) **Date of Patent:** **** Oct. 20, 2020**

(54) **INFLATABLE TOWABLE VEHICLE**

(71) Applicant: **SDS Asia Limited, BVI #1748971,**
Hong Kong (CN)

(72) Inventor: **Leroy L. Peterson,** Omaha, NE (US)

(73) Assignee: **SDS Asia Limited, BVI #1748971,**
Hong Kong (CN)

(**) Term: **15 Years**

(21) Appl. No.: **29/662,578**

(22) Filed: **Sep. 6, 2018**

(51) **LOC (12) Cl.** **21-02**

(52) **U.S. Cl.**
USPC **D21/803**

(58) **Field of Classification Search**
USPC D21/769-770, 801, 803, 809; D12/5, 6,
D12/316; D6/392, 595, 596, 601, 604,
D6/605
CPC B63B 35/00; B63B 35/001; B63B 35/58;
B63B 35/73; B63B 35/78
See application file for complete search history.

(56) **References Cited**

U.S. PATENT DOCUMENTS

D746,934 S *	1/2016	Hsu	D21/803
D765,202 S *	8/2016	Peterson	D21/803
D777,281 S *	1/2017	Peterson	D21/803
D803,965 S *	11/2017	Peterson	D21/803
D811,507 S *	2/2018	Peterson	B63B 35/73 D21/803

* cited by examiner

Primary Examiner — Zenia I Bennett
(74) *Attorney, Agent, or Firm* — Suiter Swantz pc llo

(57) **CLAIM**

The ornamental design for an inflatable towable vehicle, as shown and described.

DESCRIPTION

FIG. 1 is a perspective view showing a first embodiment of my new design;
FIG. 2 is a top plan view showing the first embodiment of our new design;
FIG. 3 is a bottom plan view showing the first embodiment of our new design;
FIG. 4 is a front elevation view showing the first embodiment of our new design;
FIG. 5 is a rear elevation view showing the first embodiment of our new design;
FIG. 6 is a right side elevation view showing the first embodiment of our new design;
FIG. 7 is a left side elevation view showing the first embodiment of our new design;
FIG. 8 is a perspective view showing a second embodiment of our new design;
FIG. 9 is a top plan view showing the second embodiment of our new design;
FIG. 10 is a bottom plan view showing the second embodiment of our new design;
FIG. 11 is a front elevation view showing the second embodiment of our new design;
FIG. 12 is a rear elevation view showing the second embodiment of our new design;
FIG. 13 is a right side elevation view showing the second embodiment of our new design; and,
FIG. 14 is a left side elevation view showing the second embodiment of our new design.
The broken lines showing stitching, a middle section extending from a front to a rear, a bottom portion, straps, and handles of FIGS. 1-14 form no part of the claimed design.

1 Claim, 14 Drawing Sheets

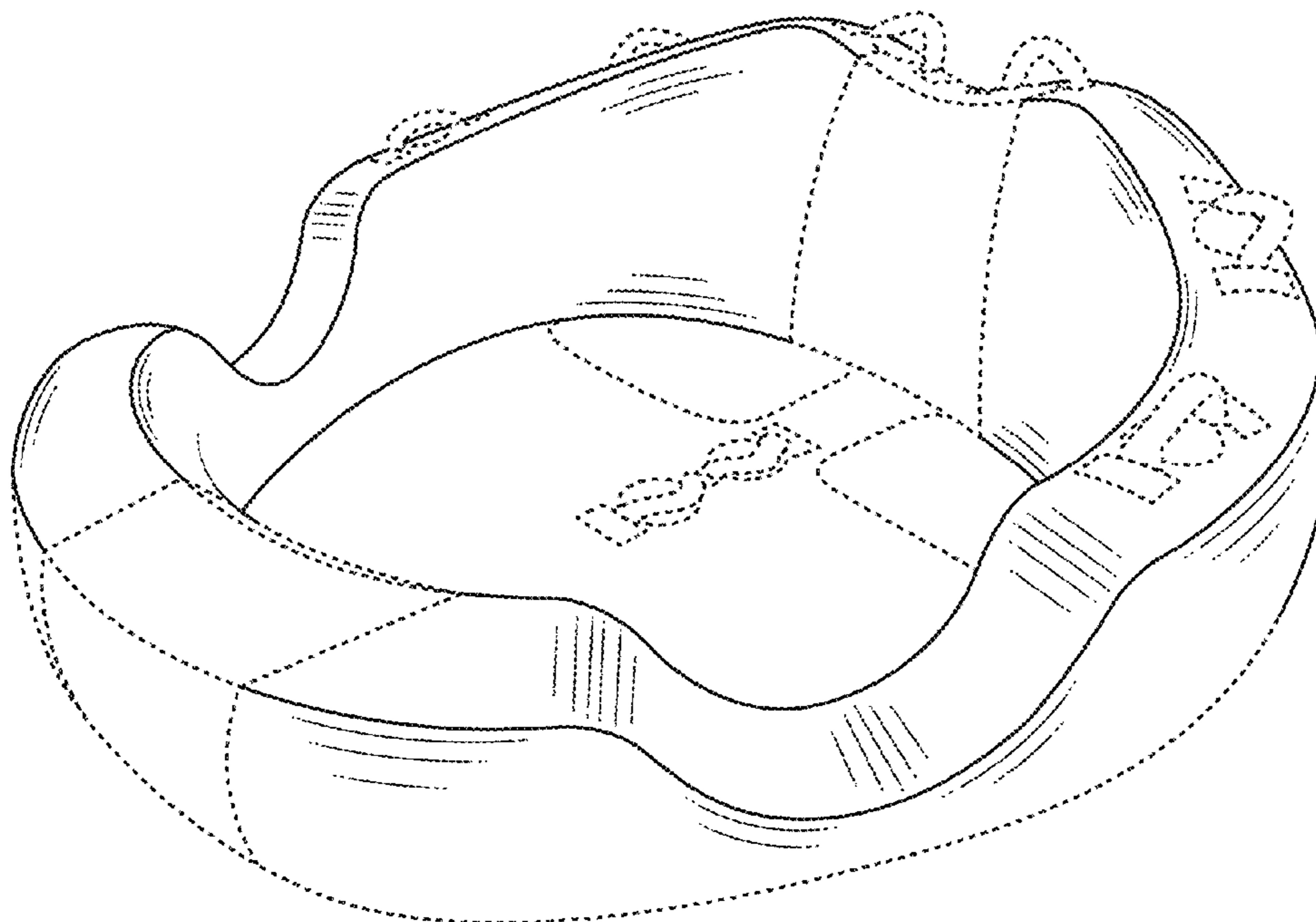

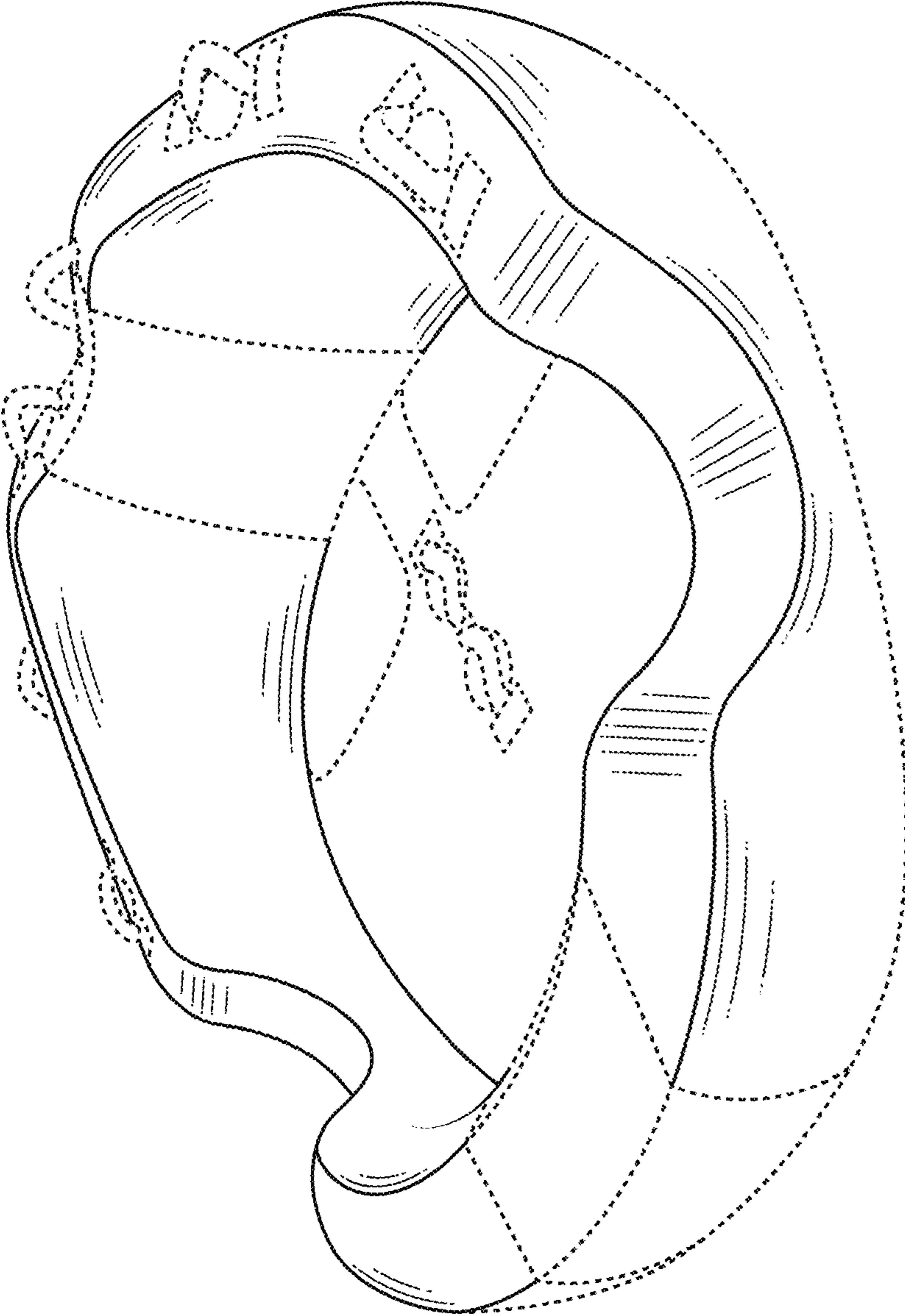

FIG.1

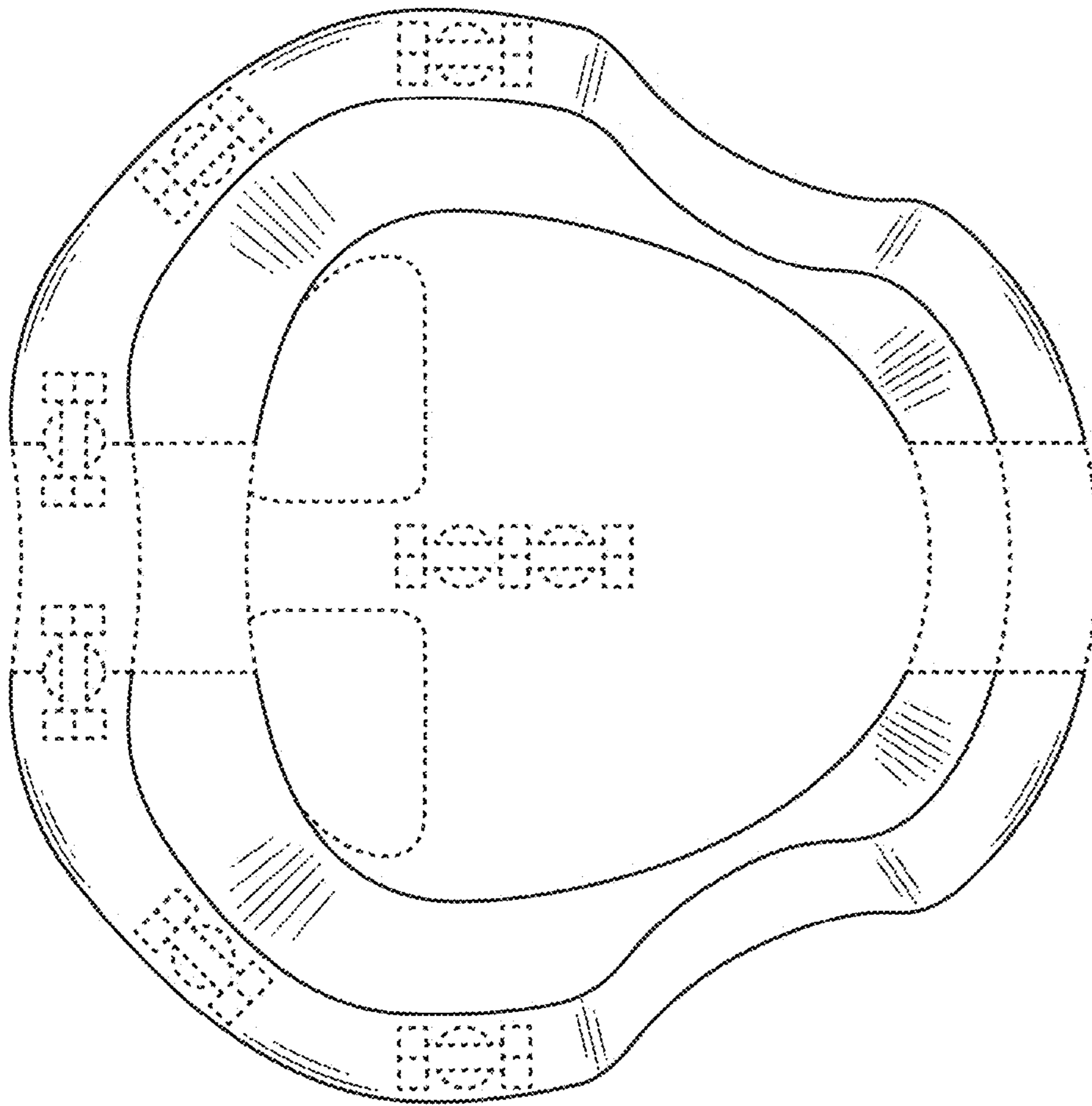

FIG. 2

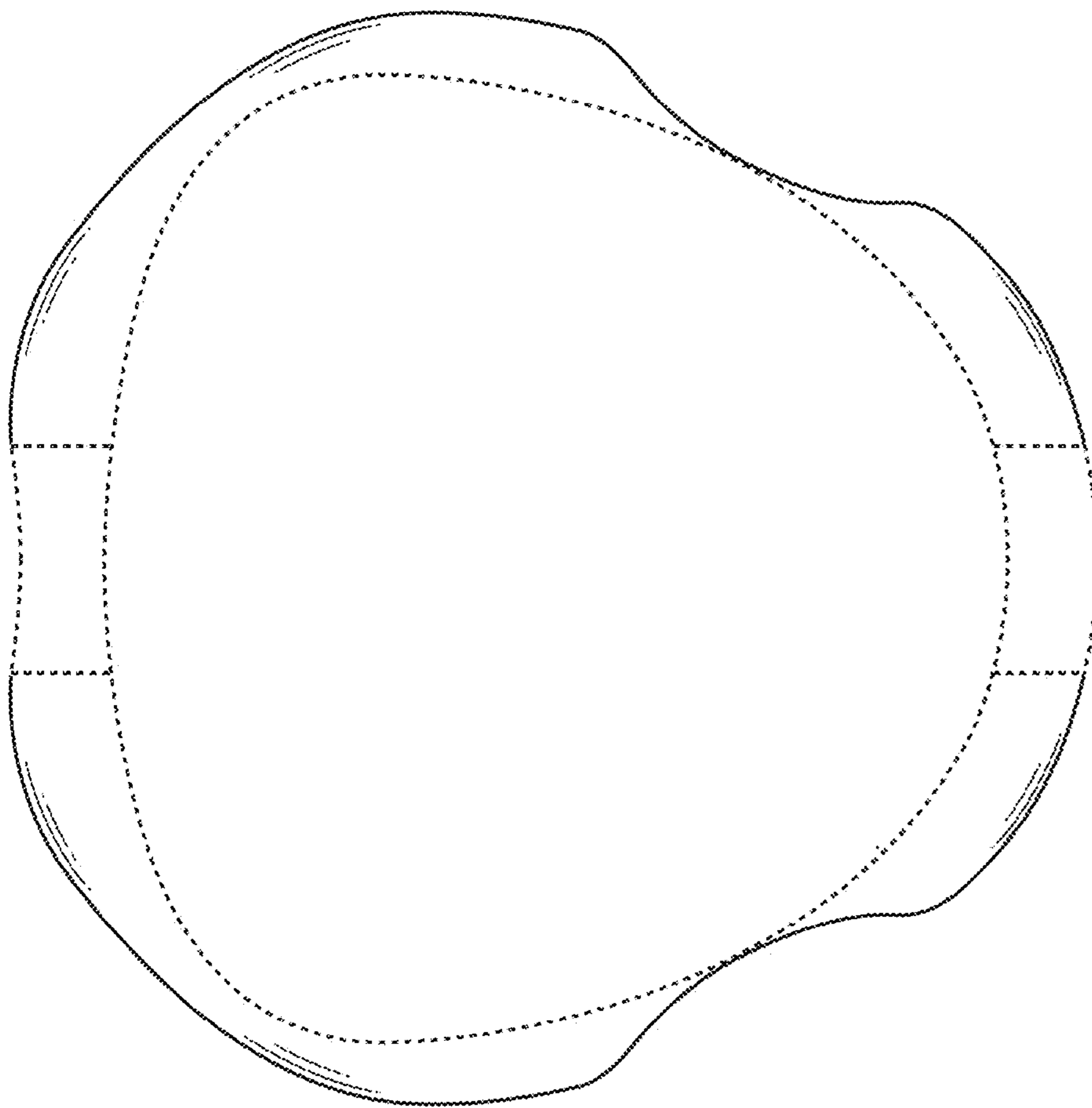

FIG. 3

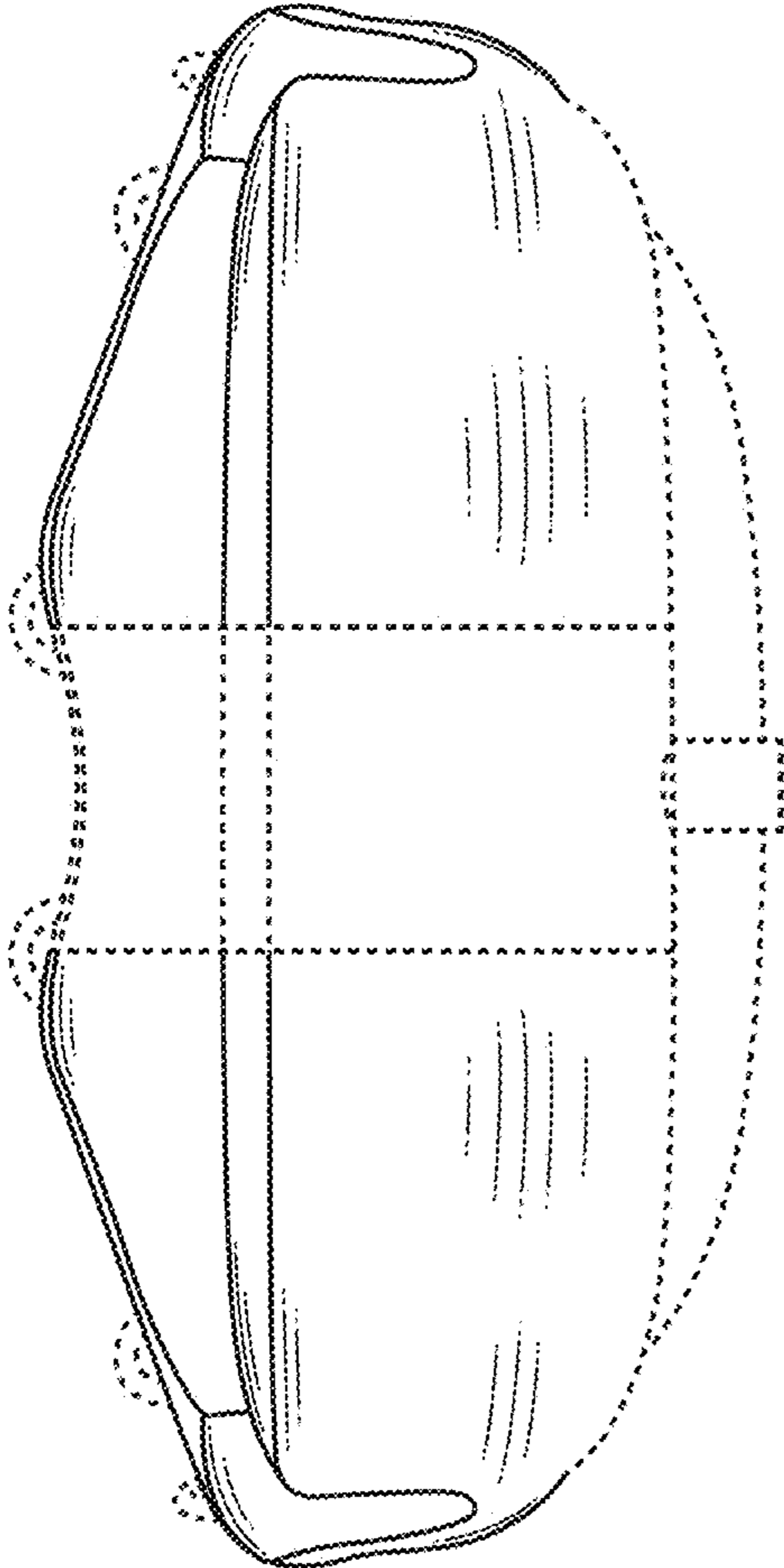

FIG.4

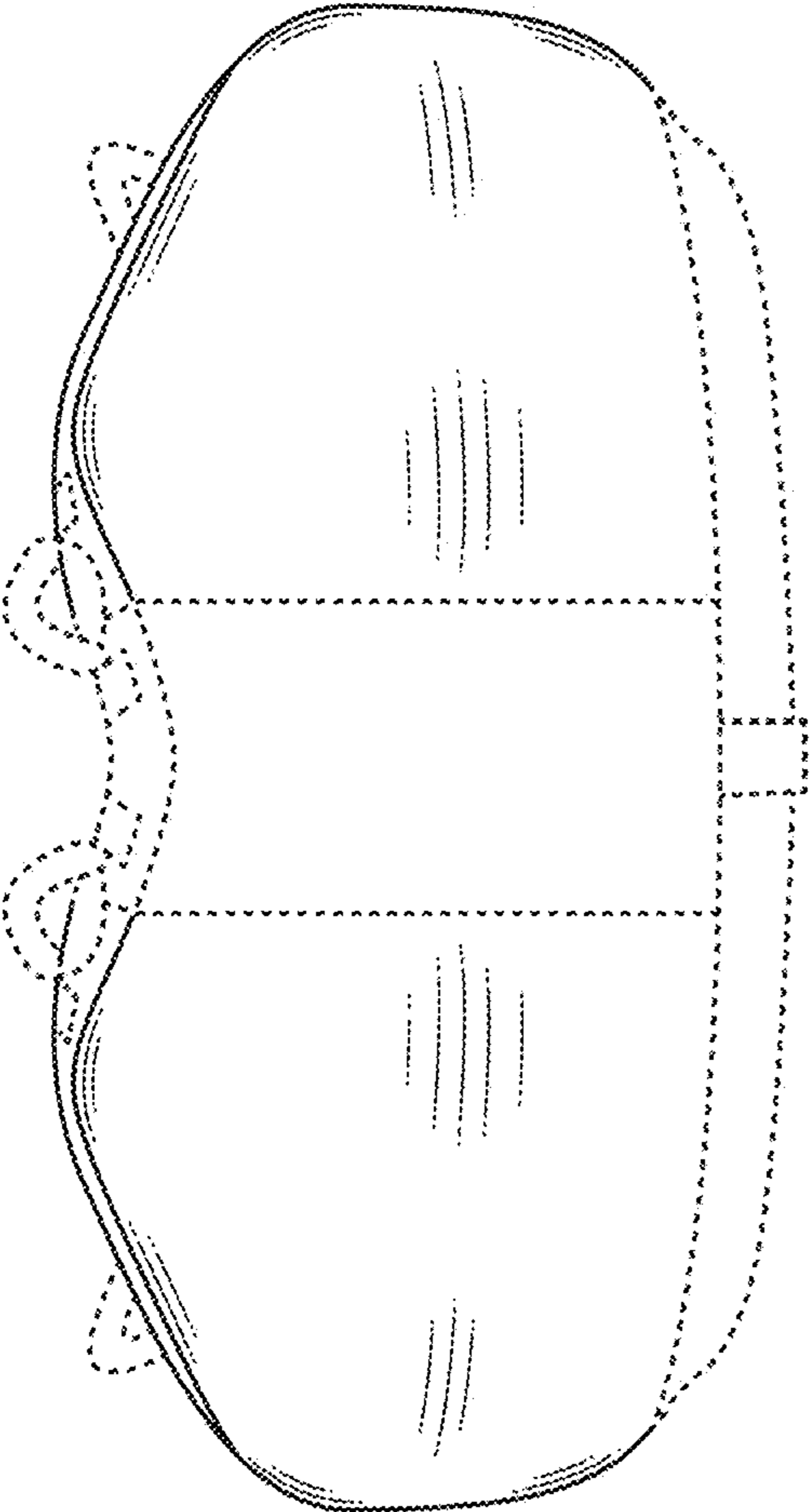

FIG. 5

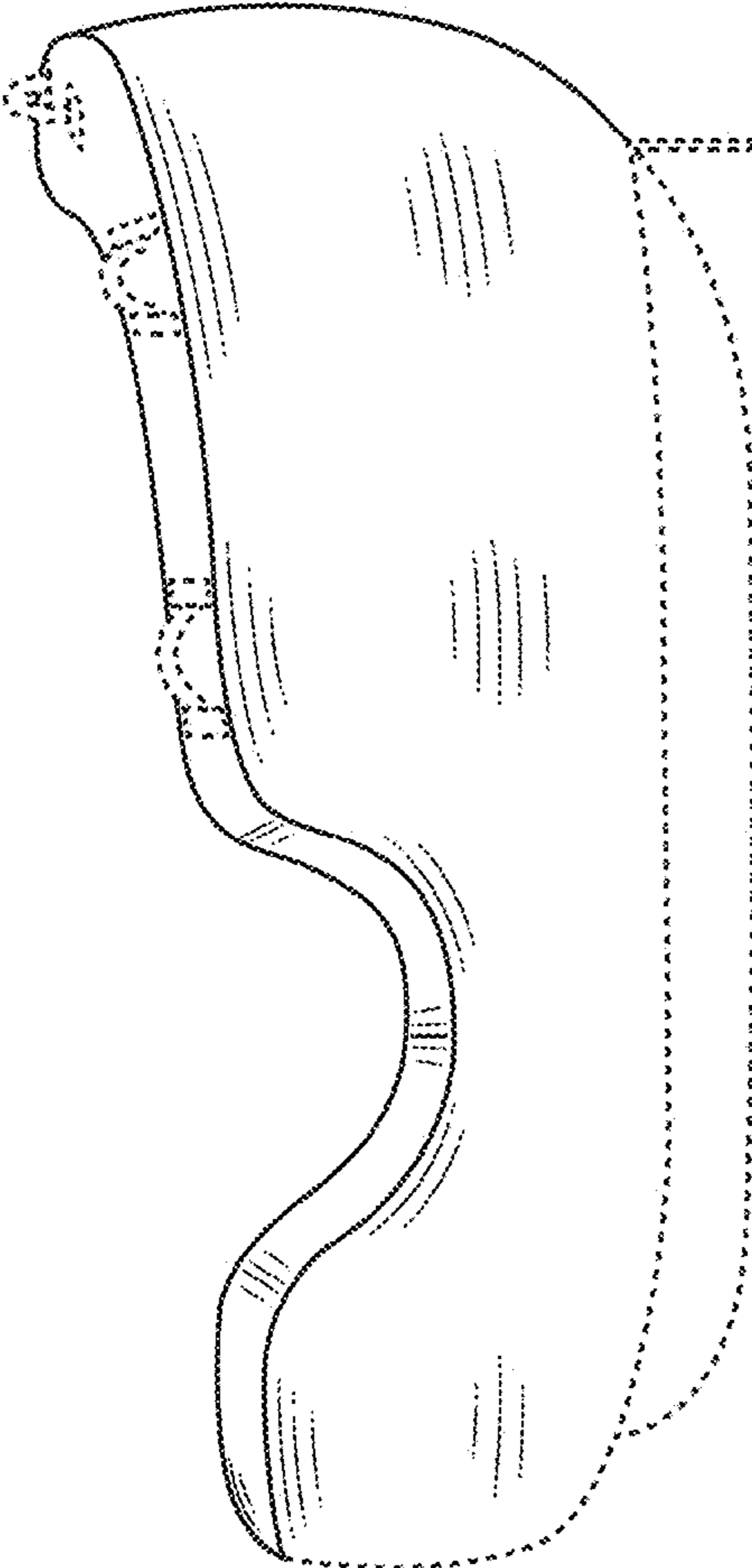

FIG.6

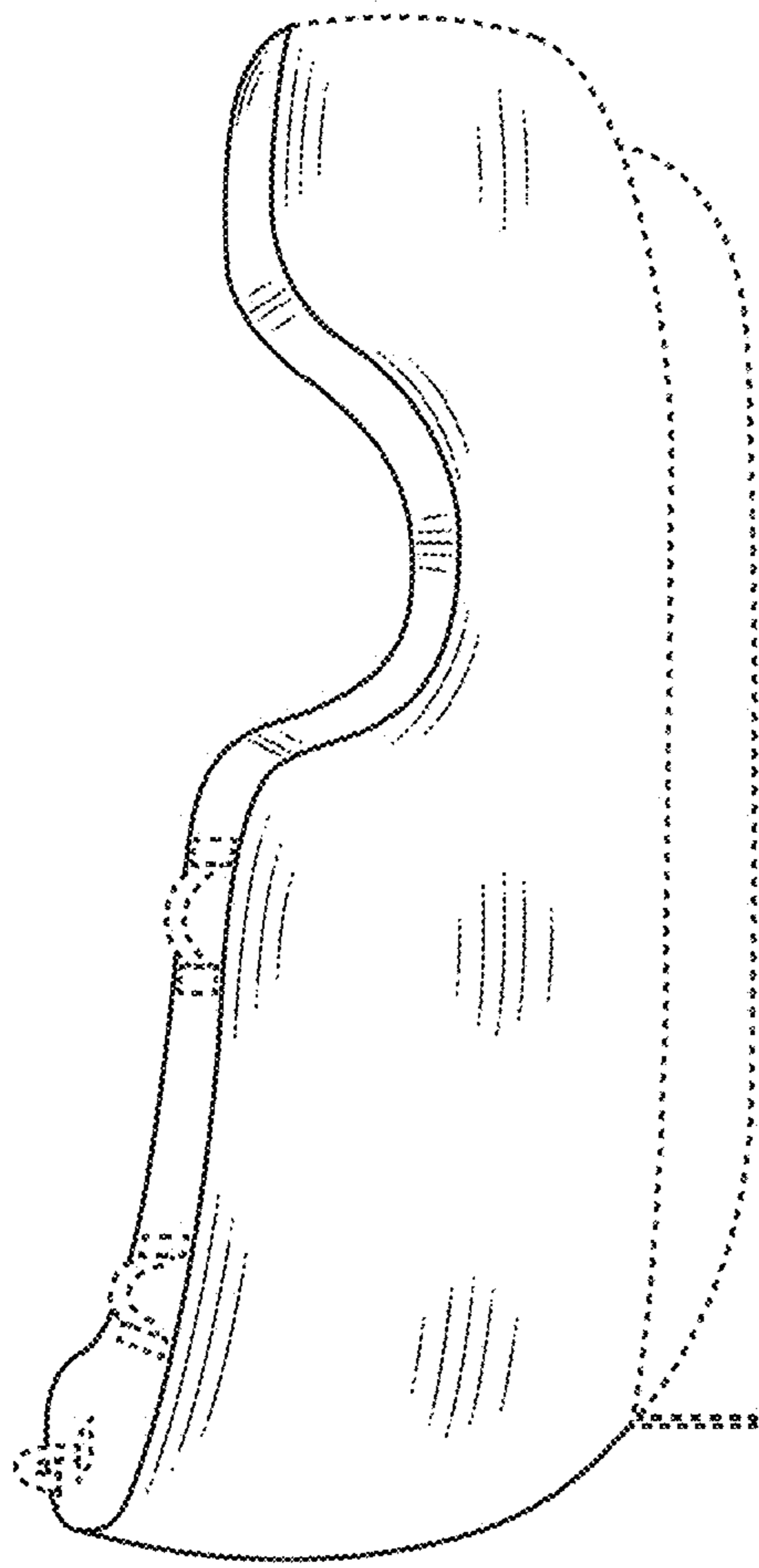

FIG.7

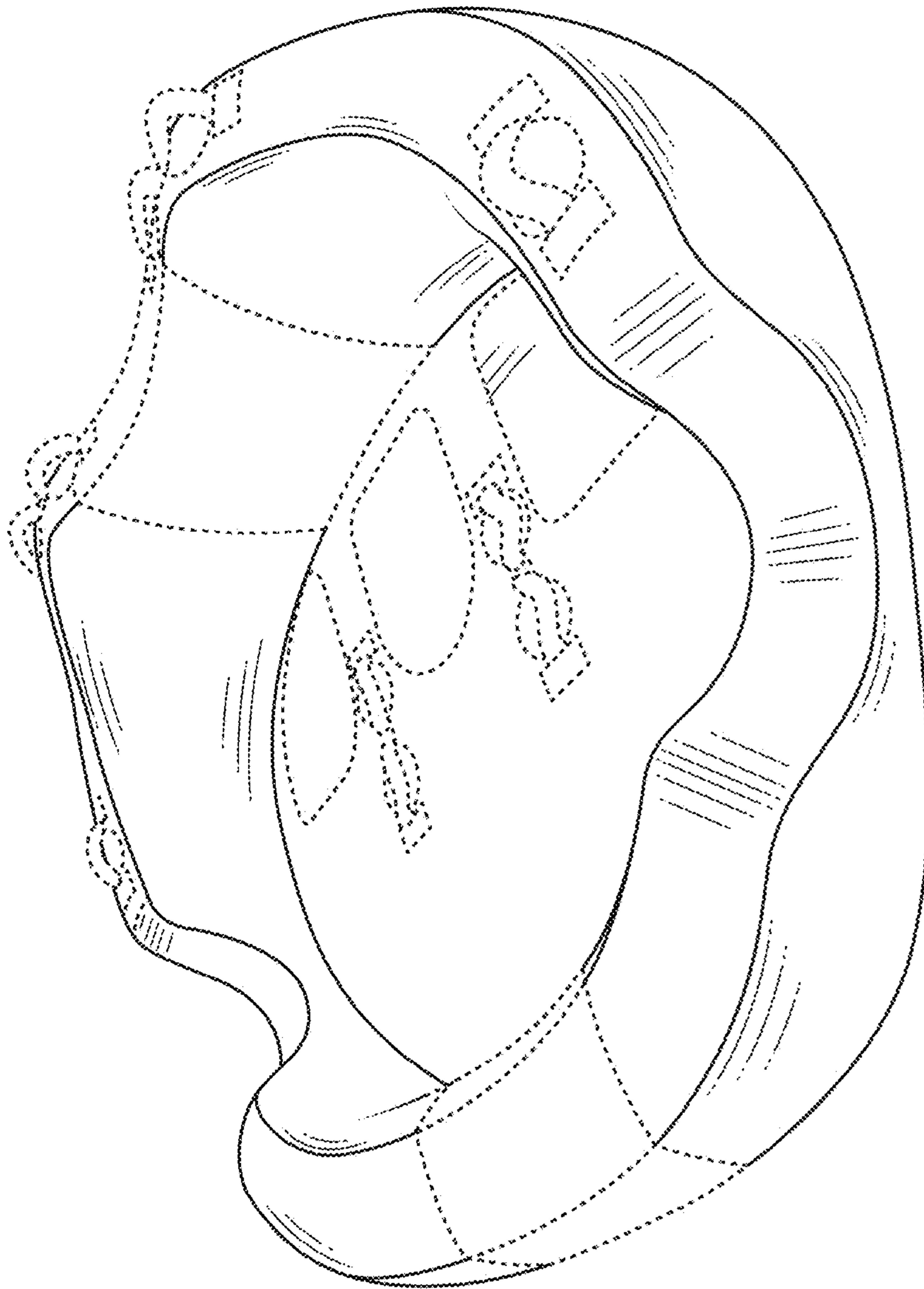

FIG. 8

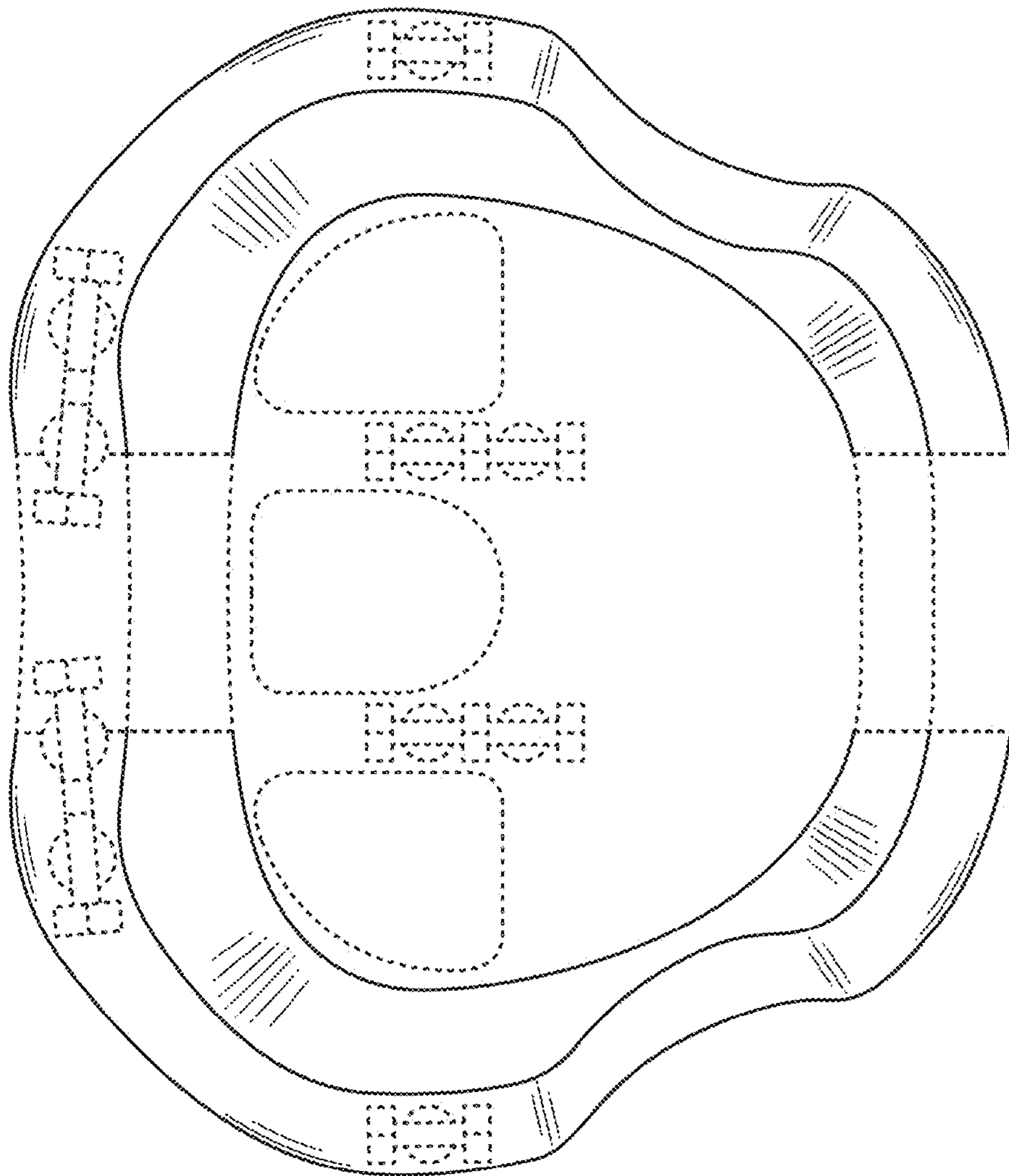

FIG. 9

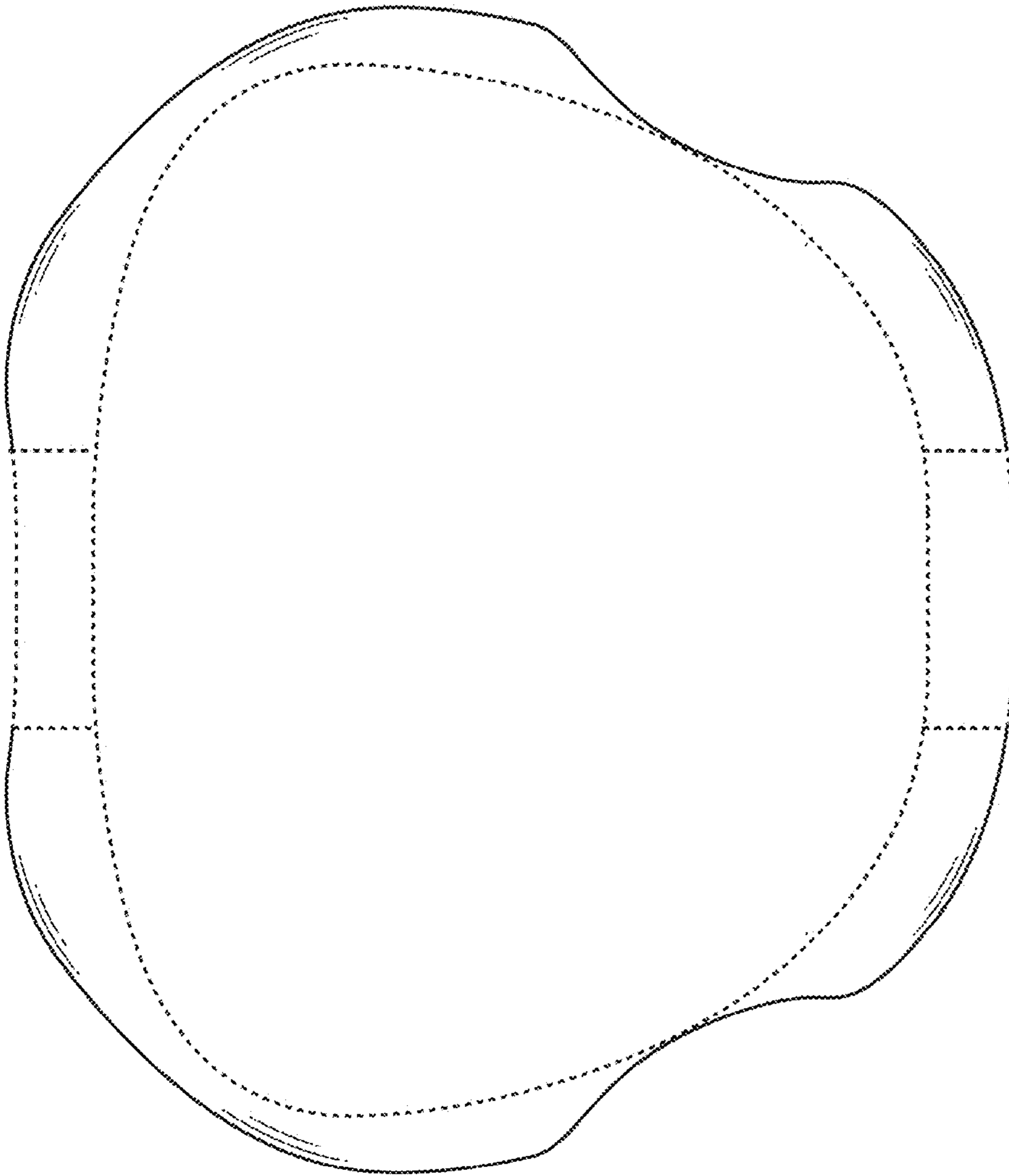

FIG.10

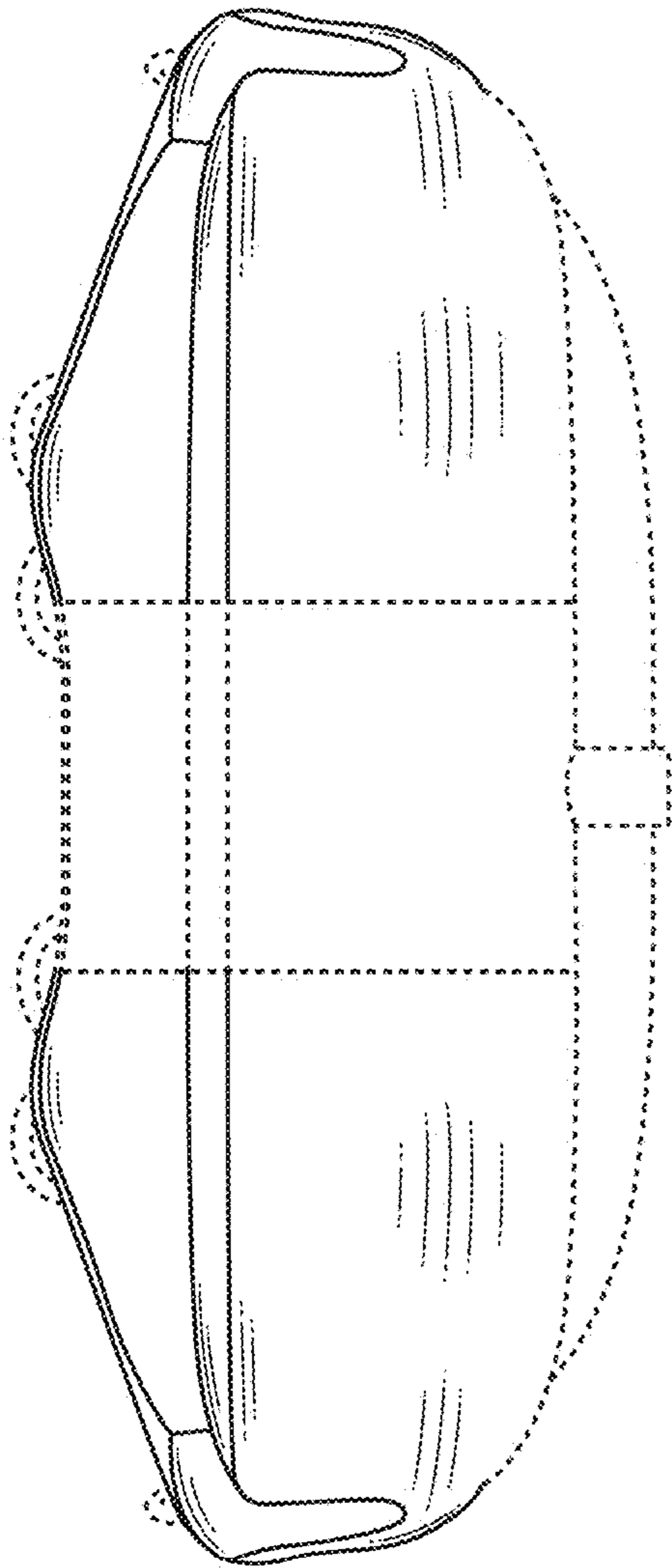

FIG.11

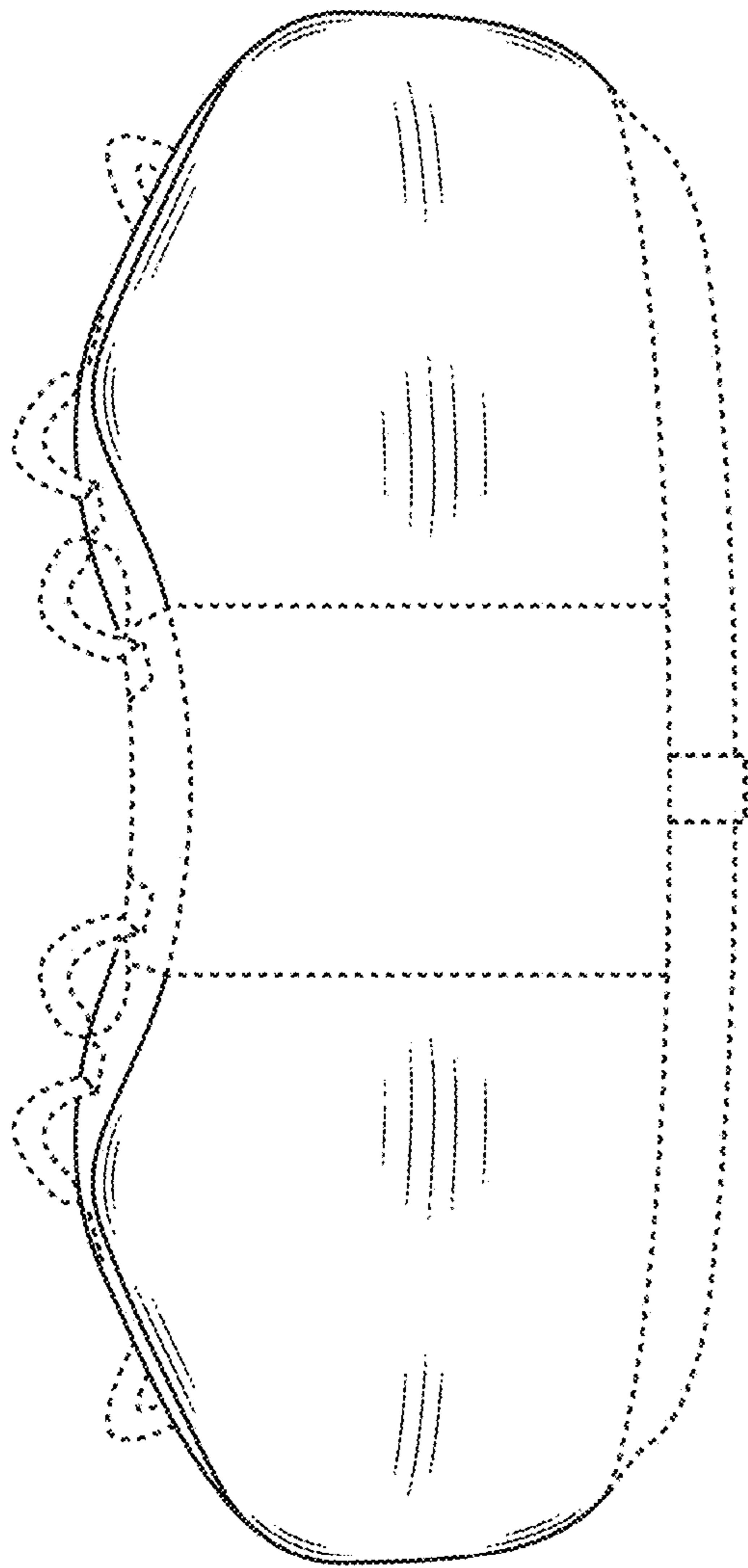

FIG.12

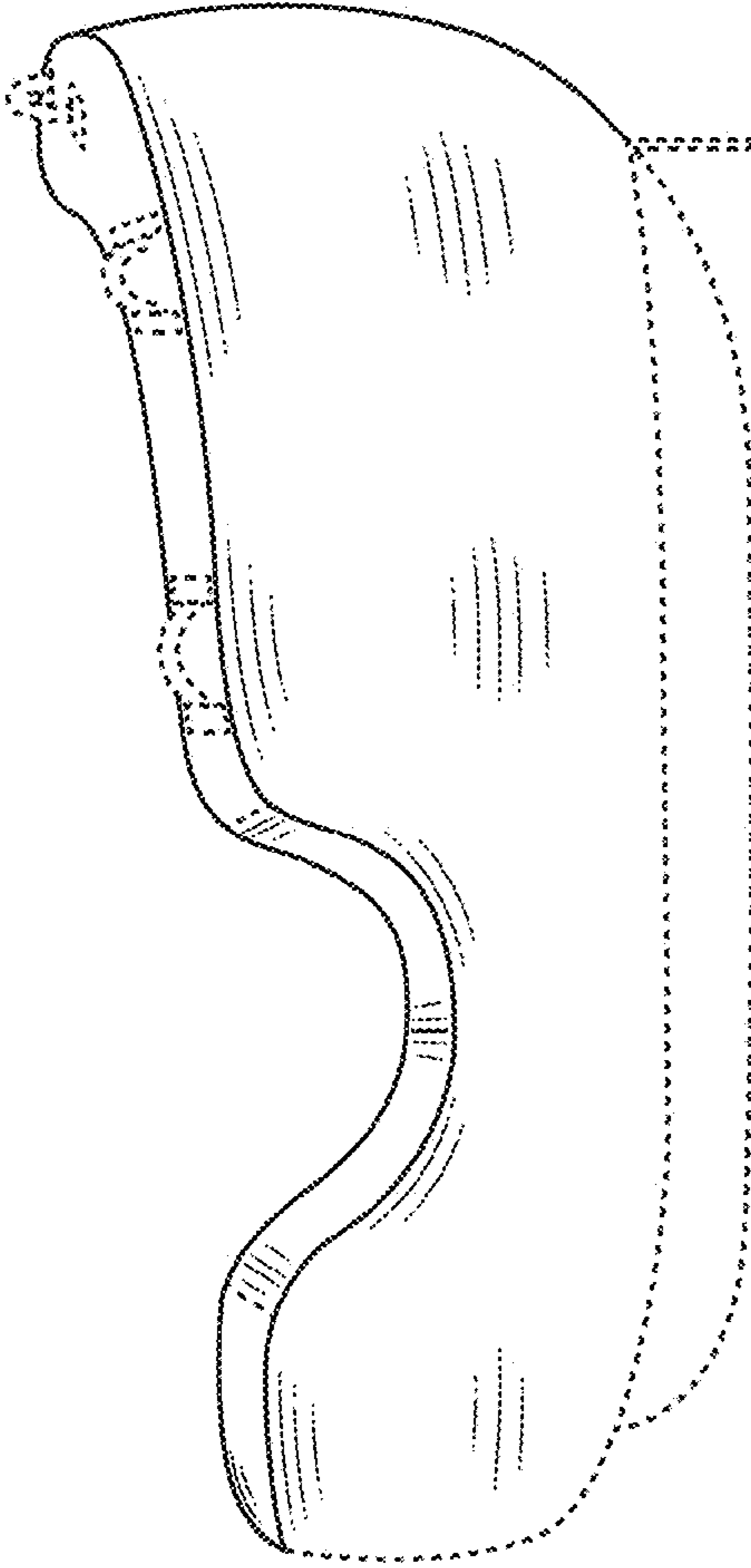

FIG. 13

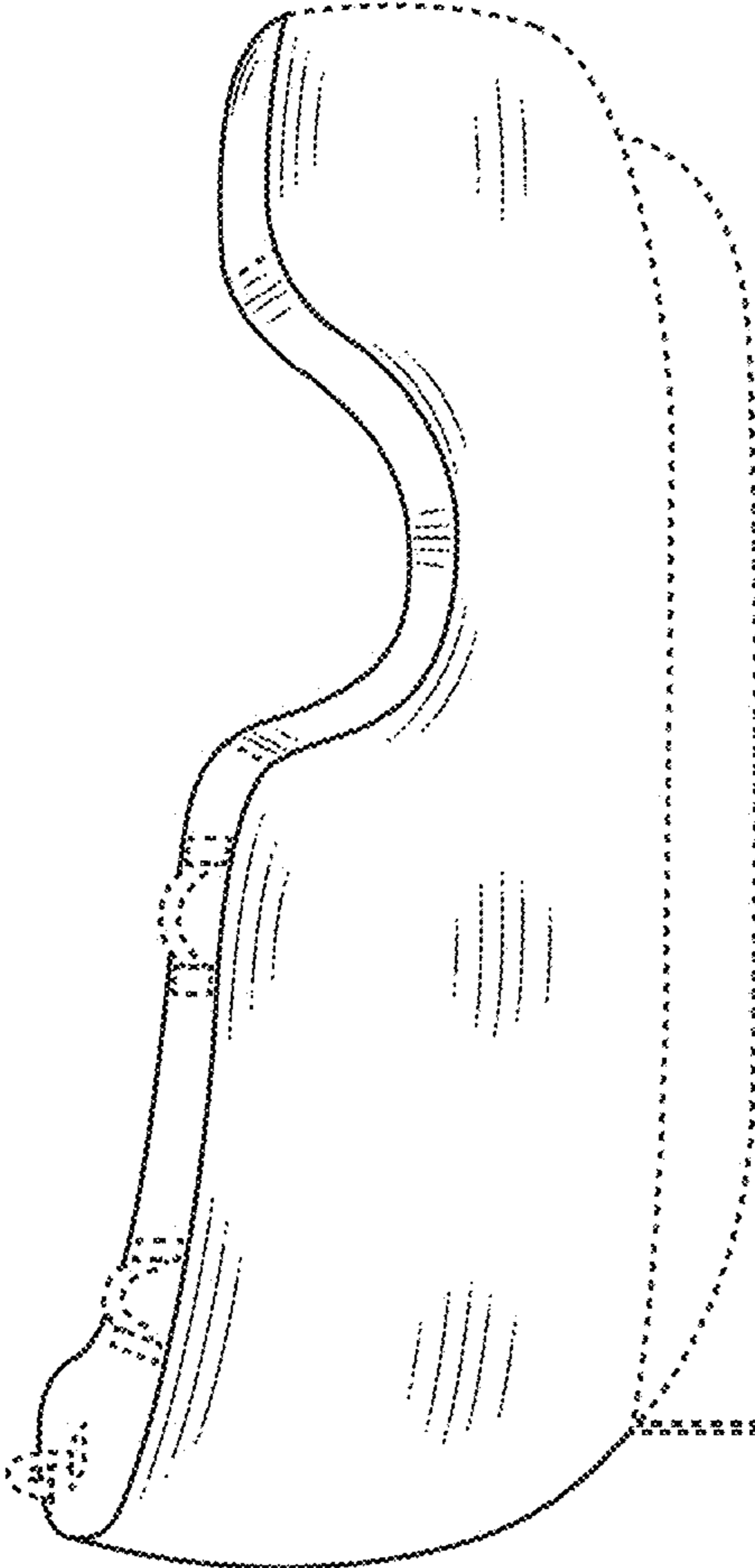

FIG.14