



US00D899377S

(12) **United States Design Patent** (10) **Patent No.:** **US D899,377 S**  
**Akana et al.** (45) **Date of Patent:** **\*\* Oct. 20, 2020**

(54) **ADAPTER**

(71) Applicant: **Apple Inc.**, Cupertino, CA (US)

(72) Inventors: **Jody Akana**, San Francisco, CA (US); **Bartley K. Andre**, Palo Alto, CA (US); **Jeremy Bataillou**, San Francisco, CA (US); **Daniel J. Coster**, San Francisco, CA (US); **Daniele De Iuliis**, San Francisco, CA (US); **M. Evans Hankey**, San Francisco, CA (US); **Julian Hoenig**, San Francisco, CA (US); **Richard P. Howarth**, San Francisco, CA (US); **Jonathan P. Ive**, San Francisco, CA (US); **Duncan Robert Kerr**, San Francisco, CA (US); **Shin Nishibori**, Kailua, CA (US); **Matthew Dean Rohrbach**, San Francisco, CA (US); **Peter Russell-Clarke**, San Francisco, CA (US); **Christopher J. Stringer**, Woodside, CA (US); **Eugene Antony Whang**, San Francisco, CA (US); **Rico Zörkendörfer**, San Francisco, CA (US)

(73) Assignee: **Apple Inc.**, Cupertino, CA (US)

(\*\*) Term: **15 Years**

(21) Appl. No.: **29/679,280**

(22) Filed: **Feb. 4, 2019**

**Related U.S. Application Data**

(63) Continuation of application No. 29/642,590, filed on Mar. 30, 2018, now Pat. No. Des. 839,837, which is a continuation of application No. 29/597,585, filed on Mar. 17, 2017, now Pat. No. Des. 814,423, which is a continuation of application No. 29/544,310, filed on Nov. 2, 2015, now Pat. No. Des. 781,785, and a continuation of application No. 29/544,312, filed on Nov. 2, 2015, now Pat. No. Des. 781,786, which is a continuation of application No. 29/481,729, filed on Feb. 10, 2014, now Pat. No. Des. 742,320, and a

continuation of application No. 29/481,729, filed on Feb. 10, 2014, now Pat. No. Des. 742,320, which is a continuation of application No. 29/431,841, filed on Sep. 11, 2012, now Pat. No. Des. 699,188.

(51) **LOC (12) Cl.** ..... **13-03**

(52) **U.S. Cl.**  
USPC ..... **D13/147**

(58) **Field of Classification Search**  
USPC ..... D13/101, 107, 110, 118, 133, 147, 153, D13/154; D14/432, 433, 435.1  
CPC ..... H01R 12/58; H01R 24/20; H01R 24/00; H01R 12/592  
See application file for complete search history.

(56) **References Cited**

**U.S. PATENT DOCUMENTS**

D304,028 S	10/1989	Matsuzaki
5,179,501 A	1/1993	Ocken et al.
D336,746 S	6/1993	Tse
D369,157 S	4/1996	Ohmori et al.
5,568,006 A	10/1996	Luff et al.
D399,047 S	10/1998	Yoshida et al.
6,137,710 A	10/2000	Iwasaki et al.
D446,499 S	8/2001	Andre et al.
D452,245 S	12/2001	Wallace et al.
D452,246 S	12/2001	Wallace et al.
D454,110 S	3/2002	Andre et al.
6,483,038 B2	11/2002	Lee et al.
D487,747 S	3/2004	Yu et al.
D490,796 S	6/2004	Allen
6,948,984 B2	9/2005	Chen et al.
D515,545 S	2/2006	Griffin
D522,463 S	6/2006	Novotney et al.
D525,977 S	8/2006	Yao
7,094,089 B2	8/2006	Andre et al.
D531,127 S	10/2006	Zhong et al.
D534,184 S	12/2006	Leija et al.
D534,545 S	1/2007	Leija et al.
D537,036 S	2/2007	Chen
D537,780 S	3/2007	Suckle
D543,156 S	5/2007	Suckle
D552,099 S	10/2007	Nishizawa et al.
D552,604 S	10/2007	Andre et al.
D558,145 S	12/2007	Stavoe et al.
D563,899 S	3/2008	Goetz et al.
7,341,472 B2	3/2008	Chao et al.
7,354,312 B2	4/2008	Chuang
D569,848 S	5/2008	Suzuki

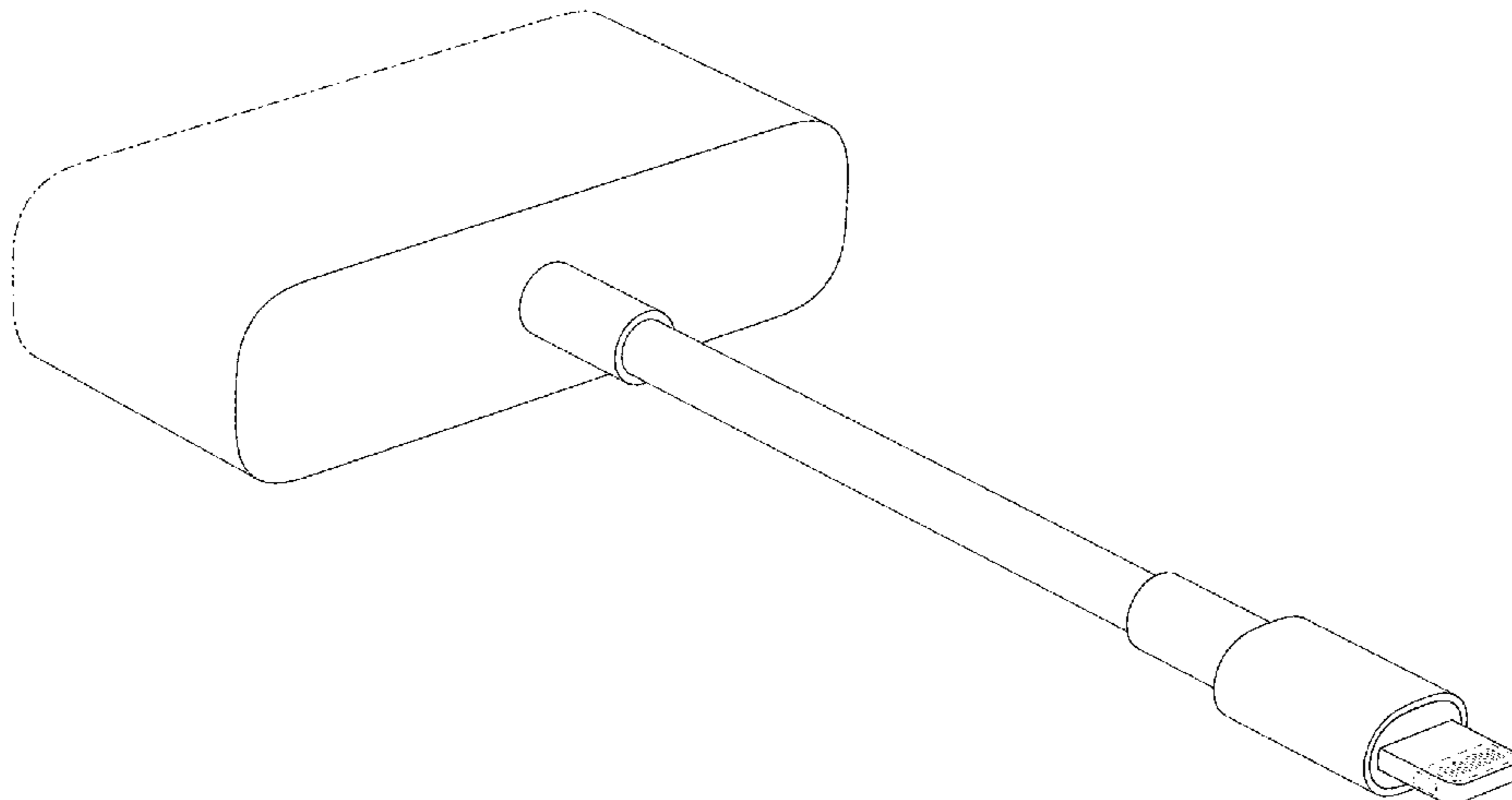

# US D899,377 S

D574,365 S	8/2008	Andre et al.	9,011,179 B2	4/2015	Siahan et al.	
D577,008 S	9/2008	Andre et al.	D731,434 S	6/2015	Akana et al.	
7,429,188 B2	9/2008	Wu	D731,489 S *	6/2015	Langhammer .....	D14/433
D577,990 S	10/2008	Andre et al.	9,059,531 B2	6/2015	Schmidt et al.	
D578,991 S	10/2008	Donovan et al.	9,065,212 B2	6/2015	Golko et al.	
D586,293 S	2/2009	Fujino	9,092,233 B2	7/2015	Andrews et al.	
D587,209 S	2/2009	Tsai et al.	9,093,803 B2	7/2015	Sooahoo et al.	
D588,545 S	3/2009	Andre et al.	9,099,856 B2	8/2015	Utterman et al.	
D594,418 S	6/2009	Fujino et al.	9,146,888 B2	9/2015	Terlizzi et al.	
D599,740 S	9/2009	Guccione et al.	D741,808 S *	10/2015	Shim .....	D13/147
D599,800 S	9/2009	Klein et al.	9,160,124 B2	10/2015	Colahan et al.	
D600,652 S	9/2009	Hong et al.	D742,320 S	11/2015	Akana et al.	
D604,725 S	11/2009	Chen	D746,780 S	1/2016	Akana et al.	
D605,650 S	12/2009	Ribeiro	9,240,700 B2	1/2016	Terlizzi et al.	
D607,886 S	1/2010	Bolotin et al.	D751,560 S	3/2016	Akana et al.	
D612,809 S	3/2010	Zhao et al.	D758,497 S	6/2016	Uhren et al.	
D617,776 S	6/2010	Hightower	9,459,670 B2	10/2016	Rich et al.	
D618,226 S	6/2010	Tong et al.	9,495,307 B2	11/2016	Zadesky et al.	
D618,240 S	6/2010	Larmour et al.	D781,785 S	3/2017	Akana et al.	
D619,963 S	7/2010	Hou	D781,786 S	3/2017	Akana et al.	
D621,785 S	8/2010	Nickol	D817,889 S	5/2018	Akana et al.	
D624,548 S	9/2010	Yamamoto	10,069,246 B1 *	9/2018	Moritake .....	H01R 13/6271
D628,151 S	11/2010	Wegener et al.	D845,953 S *	4/2019	Boehmer .....	D14/433
D628,537 S	12/2010	Nagata et al.	D868,784 S *	12/2019	Turksu .....	D14/385
D631,883 S	2/2011	Maier	D878,292 S *	3/2020	Wu .....	D13/110
D634,326 S	3/2011	Gehrke	D881,890 S *	4/2020	Wen .....	D14/433
D635,142 S	3/2011	Borislow	2002/0170972 A1	11/2002	Kim	
D636,337 S	4/2011	Smith et al.	2003/0148656 A1 *	8/2003	Huang .....	H01R 25/003 439/501
7,927,146 B2	4/2011	Wu et al.				
D637,193 S	5/2011	Andre et al.	2003/0225954 A1	12/2003	Wu	
D643,040 S	8/2011	Sedio et al.	2005/0109841 A1	5/2005	Ryan et al.	
D648,726 S	11/2011	Behar et al.	2005/0124219 A1	6/2005	Chen et al.	
D655,296 S	3/2012	Andre et al.	2005/0202727 A1	9/2005	Andre et al.	
D656,147 S	3/2012	Schlossstein	2007/0123106 A1	5/2007	Zhang	
D658,665 S	5/2012	Akana et al.	2007/0229025 A1	10/2007	Tsai et al.	
D659,150 S	5/2012	Andre	2007/0293079 A1	12/2007	Chao et al.	
D665,754 S	8/2012	Cobbett et al.	2010/0151734 A1	6/2010	Wu et al.	
D680,076 S	4/2013	McManigal	2011/0199729 A1	8/2011	Hsieh	
D680,539 S	4/2013	Kim	2012/0252256 A1	10/2012	Zhu et al.	
D682,835 S	5/2013	Daniel	2013/0084760 A1	4/2013	Siahaan et al.	
D683,703 S	6/2013	Akana et al.	2013/0175326 A1	7/2013	Jol et al.	
D684,538 S	6/2013	Akana et al.	2013/0238823 A1	9/2013	Terlizzi et al.	
D684,539 S	6/2013	Akana et al.	2013/0244472 A1	9/2013	Weber et al.	
D684,976 S	6/2013	Akana et al.	2013/0244489 A1	9/2013	Terlizzi et al.	
8,454,388 B2	6/2013	Song	2013/0244491 A1	9/2013	Sarwar et al.	
D692,390 S	10/2013	Smith et al.	2013/0244492 A1	9/2013	Golka et al.	
8,561,879 B2	10/2013	Jol et al.	2013/0279055 A1	10/2013	Mullins et al.	
D693,828 S	11/2013	Akana et al.	2013/0286522 A1	10/2013	Mullins et al.	
D694,243 S	11/2013	Akana et al.	2013/0304942 A1	11/2013	Golembeski et al.	
8,637,165 B2	1/2014	Siahaan et al.	2013/0305066 A1	11/2013	Mullins et al.	
D699,188 S	2/2014	Akana et al.	2014/0013012 A1	1/2014	Terlizzi et al.	
8,683,090 B2	3/2014	Mullins et al.	2014/0057479 A1	2/2014	Weber et al.	
8,845,363 B2	3/2014	Ardisana et al.	2014/0073170 A1	3/2014	Golko et al.	
D703,145 S	4/2014	Akana et al.	2014/0073186 A1 *	3/2014	Webb .....	H01R 12/00 439/607.58
8,708,745 B2	4/2014	Golko et al.				
D704,139 S *	5/2014	Yamamoto .....	2014/0073191 A1	3/2014	Colahan et al.	
D705,176 S	5/2014	Akana et al.	2014/0073193 A1	3/2014	Sooahoo et al.	
8,721,356 B2	5/2014	Webb et al.	2014/0075051 A1	3/2014	Zadesky et al.	
D707,180 S *	6/2014	Yi .....	2014/0075169 A1	3/2014	Andrews et al.	
D707,680 S	6/2014	Akana et al.	2014/0075210 A1	3/2014	Rich et al.	
D707,681 S	6/2014	Akana et al.	2014/0294656 A1	10/2014	Brickner et al.	
8,747,155 B2	6/2014	Weber et al.				
8,762,605 B2	6/2014	Terlizzi et al.				
D709,032 S	7/2014	Akana et al.				
8,777,666 B2	7/2014	Golko et al.				
8,799,527 B2	8/2014	Mullins et al.				
8,804,355 B2	8/2014	Utterman et al.				
D712,279 S	9/2014	Akana et al.				
D714,729 S	10/2014	Akana et al.				
D714,731 S *	10/2014	Lee .....				D13/147
8,882,529 B2	11/2014	Weber et al.				
8,886,849 B2	11/2014	Golembeski et al.				
8,888,510 B2	11/2014	Webb				
8,891,216 B2	11/2014	Mullins et al.				
8,905,793 B2	12/2014	Golko et al.				
8,974,126 B2	3/2015	Sloey et al.				
8,986,029 B2	3/2015	Webb et al.				
9,011,161 B2	4/2015	Weber et al.				
9,011,172 B2	4/2015	Weber et al.				

## FOREIGN PATENT DOCUMENTS

AU	346798	2/2013
CN	D131168 S	10/2009
CN	301901718 S	5/2012
CN	203103611 U	7/2013
CN	203225414 U	10/2013
CN	102269849 S	9/2014
EM	000623848-0001	2/2007
EM	001222905-0018	10/2010
JP	D128395	3/1997
WO	WO 2006/074348 A1	7/2006
WO	WO 2011/150403 A1	12/2011
WO	WO 2011/160138 A2	12/2011
WO	WO 2011/163256 A1	12/2011
WO	WO 2011/163260 A1	12/2011

WO WO 2012/103383 A2 8/2012  
WO WO 2013/081704 A1 6/2013  
WO WO 2014/040224 3/2014

OTHER PUBLICATIONS

“Apple Lightning to VGA Adapter”. Found online May 7, 2020 at theverge.com. Reference dated Oct. 24, 2012. Retrieved from <https://www.theverge.com/2012/10/24/3547754/apple-lightning-vga-hdmi-12w-usb-power-adapter>. (Year: 2012).\*

“Apple Lightning to VGA Adapter”. Found online May 7, 2020 at ilounge.com. Reference dated Dec. 5, 2012. Retrieved from <https://www.ilounge.com/index.php/reviews/entry/apple-lightning-to-vga-adapter>. (Year: 2012).\*

“Apple Lightning Adapter”. Found online May 7, 2020 at youtube.com. Reference dated Jan. 10, 2013. Retrieved from <https://www.youtube.com/watch?v=MftUx0p0gQc>. (Year: 2013).\*

Apple 30-pin to VGA Adapter, <<http://store.apple.com/us/product/MC552ZM/B/applevgaadapter?fnode=3a&fs=m.ipadCompatibility%3Dipad2>>, accessed on Aug. 28, 2013, 4 pages.

\* cited by examiner

*Primary Examiner* — Kendra Leslie Hamilton

*Assistant Examiner* — Amanda Christensen

(74) *Attorney, Agent, or Firm* — Sterne, Kessler, Goldstein & Fox P.L.L.C.

(57) **CLAIM**

The ornamental design for an adapter, as shown and described.

**DESCRIPTION**

FIG. 1 is a top, front, right perspective view of an adapter showing our new design;

FIG. 2 is a top, rear, left perspective view thereof;

FIG. 3 is a top plan view thereof, the bottom plan view being a mirror image thereof;

FIG. 4 is a left side elevation view thereof;

FIG. 5 is a right side elevation view thereof;

FIG. 6 is a rear elevation view thereof; and,

FIG. 7 is a front elevation view thereof.

The equal-length broken lines depict portions of the adapter that form no part of the claimed design. The dash-dot-dash broken lines define the boundaries of the claim and form no part of the claimed design.

**1 Claim, 5 Drawing Sheets**

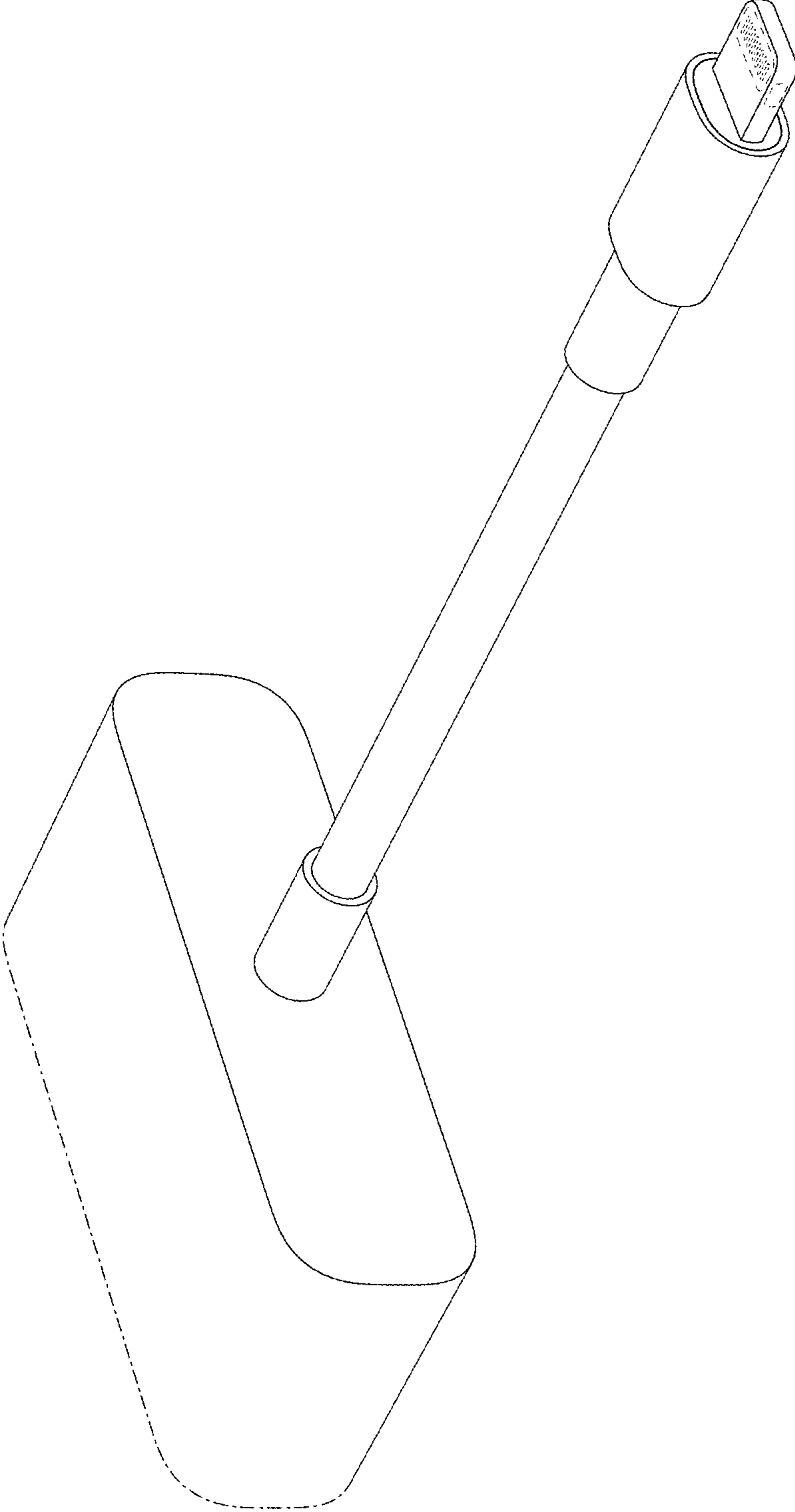

FIG. 1

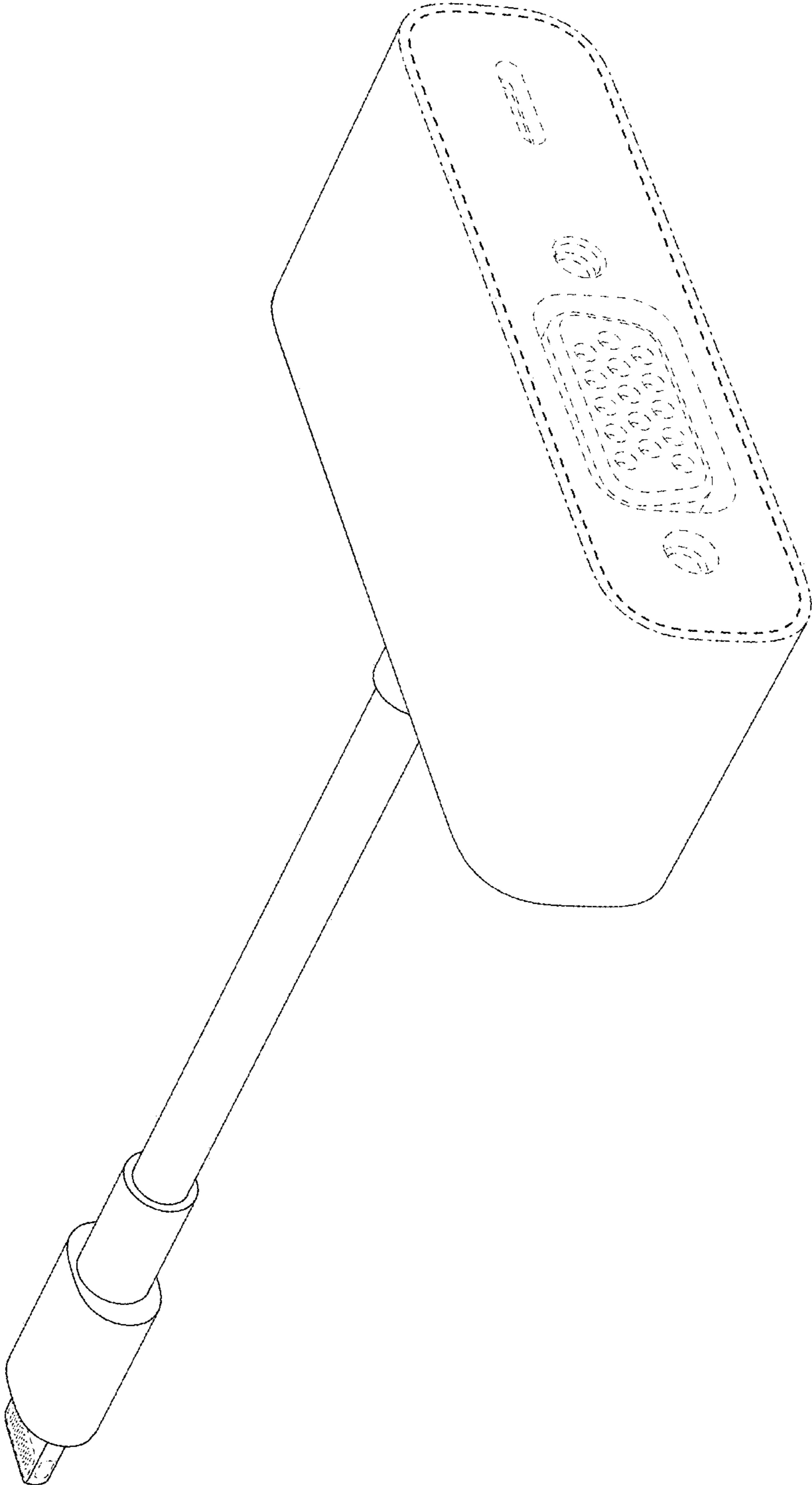
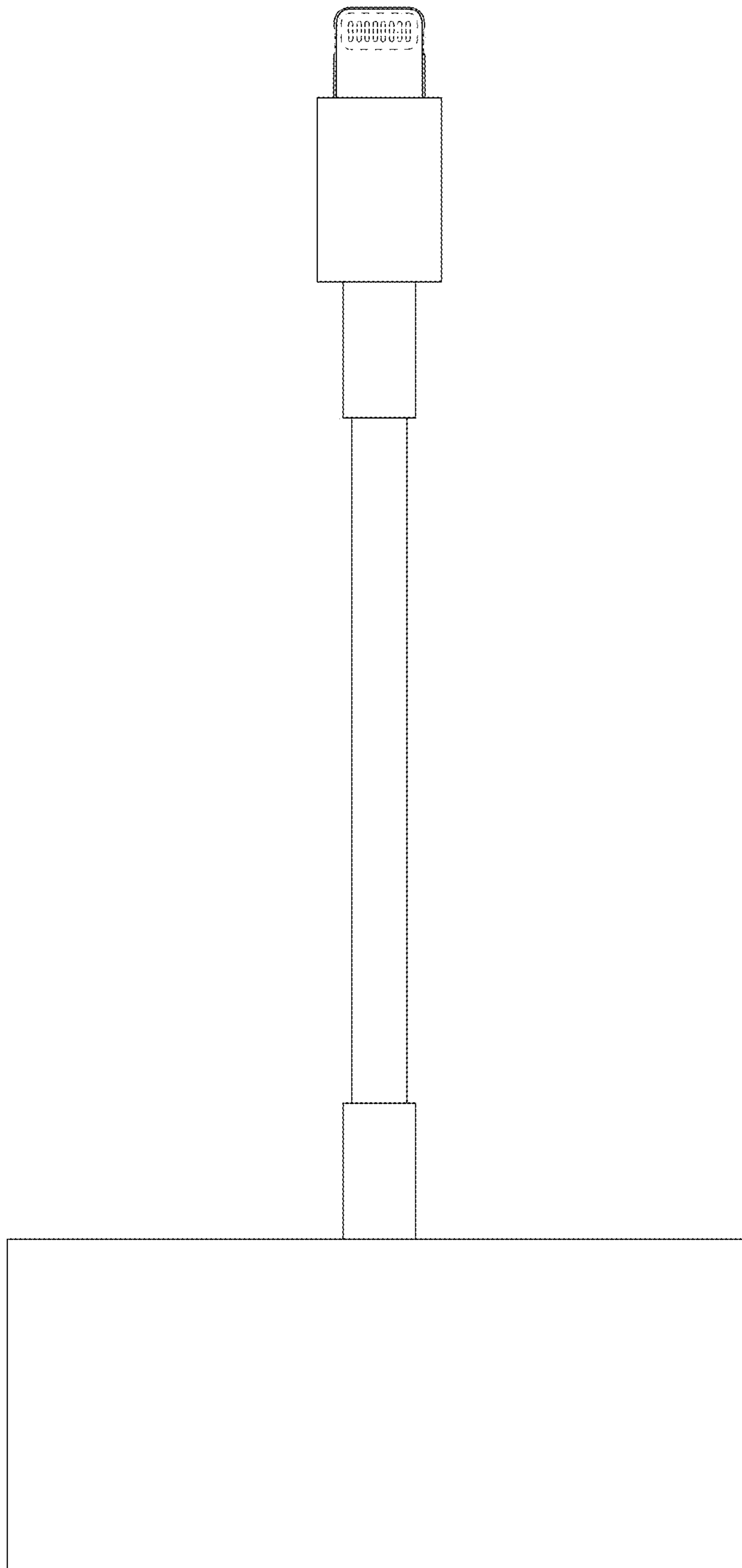
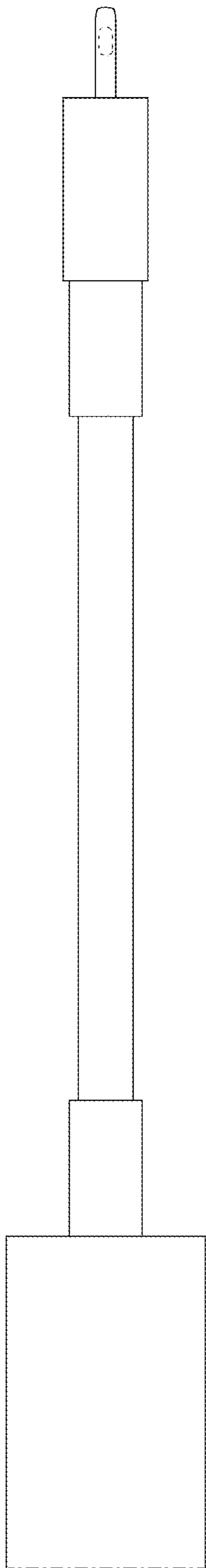

FIG. 2



**FIG. 3**



**FIG. 4**

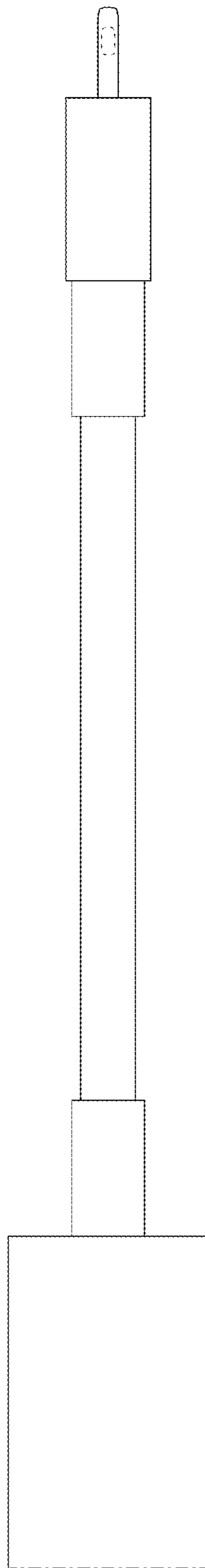

**FIG. 5**

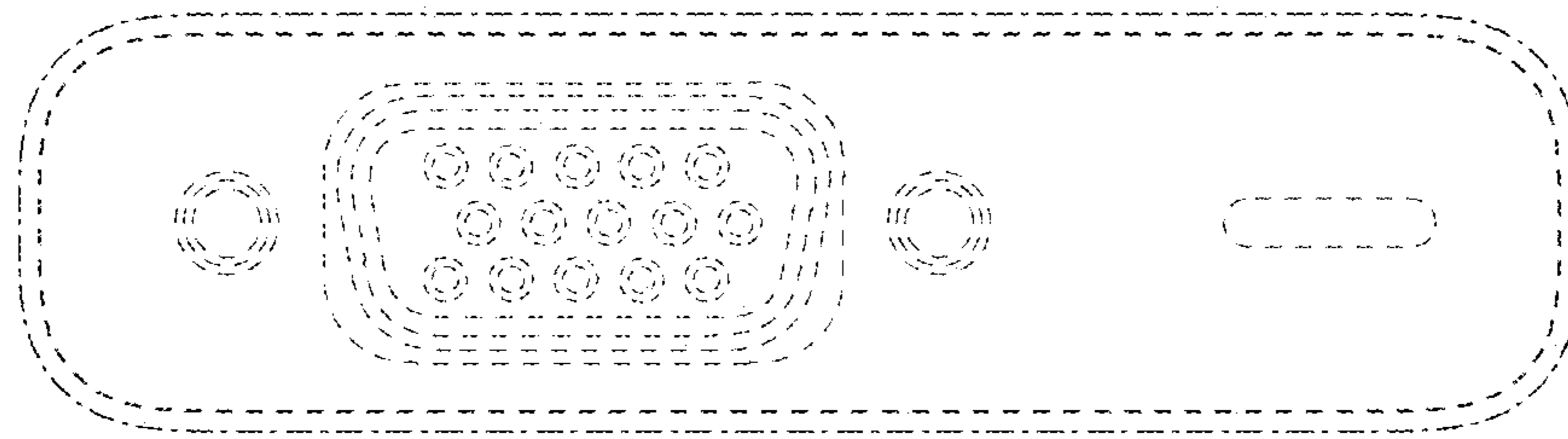

**FIG. 6**

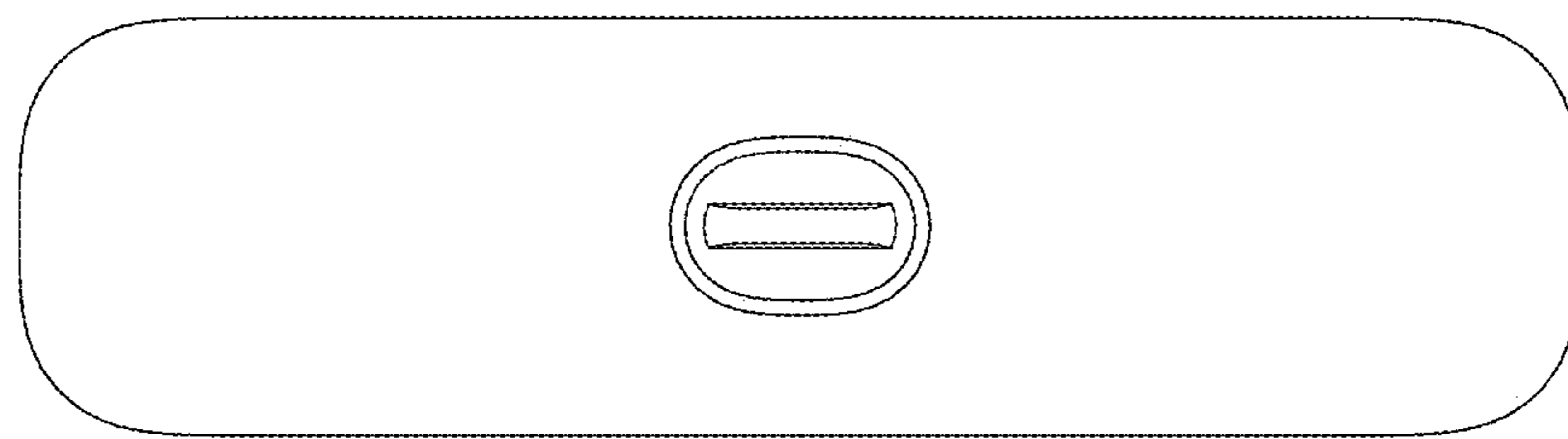

**FIG. 7**