



US00D899091S

(12) **United States Design Patent** (10) **Patent No.:** **US D899,091 S**
Kukucka et al. (45) **Date of Patent:** **** Oct. 20, 2020**

(54) **ELONGATED ALTERNATE RAIL BODY OF A TOOL HOLDING DEVICE**

(71) Applicant: **GRIP HOLDINGS LLC**, Brandon, FL (US)

(72) Inventors: **Paul Kukucka**, Brandon, FL (US);
Thomas Stefan Kukucka, Brandon, FL (US)

(73) Assignee: **GRIP HOLDINGS LLC**, Brandon, FL (US)

(**) Term: **15 Years**

(21) Appl. No.: **29/731,310**

(22) Filed: **Apr. 14, 2020**

Related U.S. Application Data

(63) Continuation-in-part of application No. 29/710,567, filed on Oct. 24, 2019.

(51) **LOC (12) Cl.** **03-01**

(52) **U.S. Cl.**
USPC **D3/312**

(58) **Field of Classification Search**
USPC D3/226, 228, 245, 246, 283-284,
D3/303-304, 308, 313, 315, 319, 328;
D6/515, 567, 574, 675, 682, 682.1;
D8/349, 354, 373, 376
CPC B25H 3/003; B25H 3/006; B25H 3/06;
B25F 25/006; B25F 5/02; B25F 5/021;
B25B 29/00; B25B 33/00
See application file for complete search history.

(56) **References Cited**

U.S. PATENT DOCUMENTS

D251,071 S * 2/1979 Brady D25/119
D251,806 S * 5/1979 Brady D25/119

4,927,020 A 5/1990 Randy
D322,486 S * 12/1991 Westphal D25/122
D345,427 S * 3/1994 Moss D25/119
D364,104 S * 11/1995 Johnson D10/69
D422,718 S * 4/2000 Chaney D25/122
D424,213 S * 5/2000 Chaney D25/122
D457,052 S 5/2002 Snyder
6,698,603 B2 3/2004 Lawson et al.
6,827,320 B2 12/2004 Yeh
7,950,534 B2 5/2011 Kao
D669,685 S * 10/2012 Legreca D3/304
D669,769 S * 10/2012 Lapping D25/122

(Continued)

FOREIGN PATENT DOCUMENTS

WO DM//103 611 8/2018

Primary Examiner — Kelley A Donnelly

(57) **CLAIM**

The ornamental design for an elongated alternate rail body of a tool holding device, as shown and described.

DESCRIPTION

FIG. 1 is a top perspective view of an elongated alternate rail body of a tool holding device showing my new design; FIG. 2 is a bottom perspective view thereof; FIG. 3 is a front elevational view thereof; the rear view being a mirror image; FIG. 4 is a top plan view thereof; and, FIG. 5 is a right side elevational view thereof; the left side being a mirror image.

The left side elevational view is a mirror image of the right elevational view.

The rear elevational view is a mirror image of the front elevational view.

The broken line showing the elongated alternate rail body of a tool holding device in FIGS. 1-3 are included for the purpose of showing environmental structure and form no part of the claimed design.

1 Claim, 5 Drawing Sheets

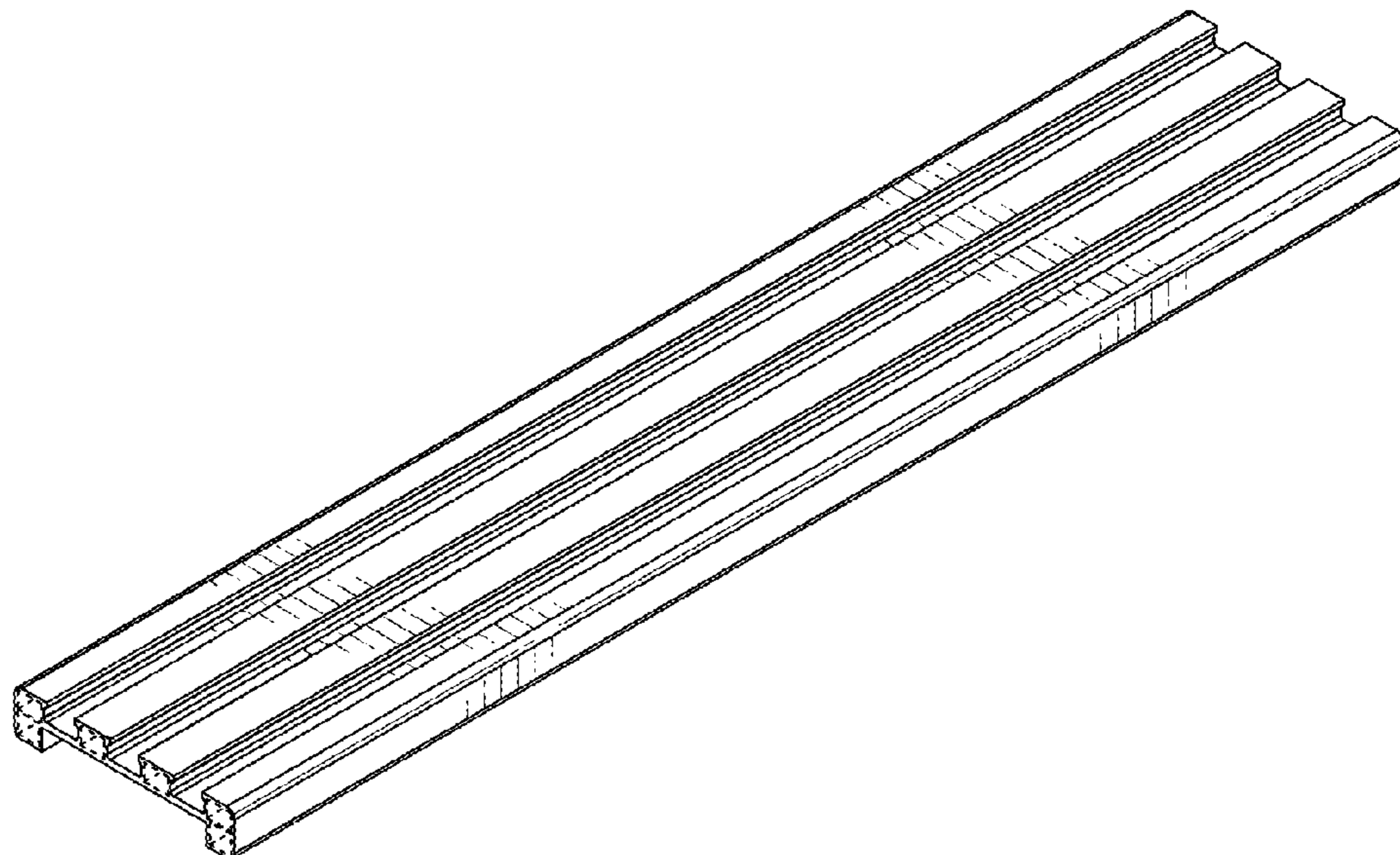

(56)

References Cited

U.S. PATENT DOCUMENTS

8,813,957 B1 * 8/2014 Kao B25H 3/003
206/378
D742,546 S * 11/2015 Singh D25/119
9,186,790 B1 11/2015 Kao
9,538,862 B2 * 1/2017 Kao B25H 3/003
9,545,716 B2 1/2017 Hsieh
D787,185 S 5/2017 Hsieh
9,662,781 B1 * 5/2017 Kao B25H 3/04
D800,347 S * 10/2017 Blick D25/119
D803,566 S * 11/2017 Hsieh D3/312
9,821,451 B1 * 11/2017 Kao B25H 3/04
9,878,441 B1 * 1/2018 Kao B25H 3/06
D818,194 S * 5/2018 Trzesniowski D26/138
10,105,835 B1 * 10/2018 Kao B25H 3/04
D852,017 S * 6/2019 Kao D8/71
D872,931 S * 1/2020 Tremaine D26/138
D874,025 S * 1/2020 Kittur D25/119
D877,686 S * 3/2020 Connellan D12/412
2015/0336262 A1 * 11/2015 Kao B25H 3/003
206/378
2017/0259425 A1 * 9/2017 Kao B25H 3/003
2017/0312910 A1 * 11/2017 Kao B25H 3/04
2017/0361453 A1 * 12/2017 Kao B25H 3/04
2020/0147800 A1 * 5/2020 Chen B66F 9/24

* cited by examiner

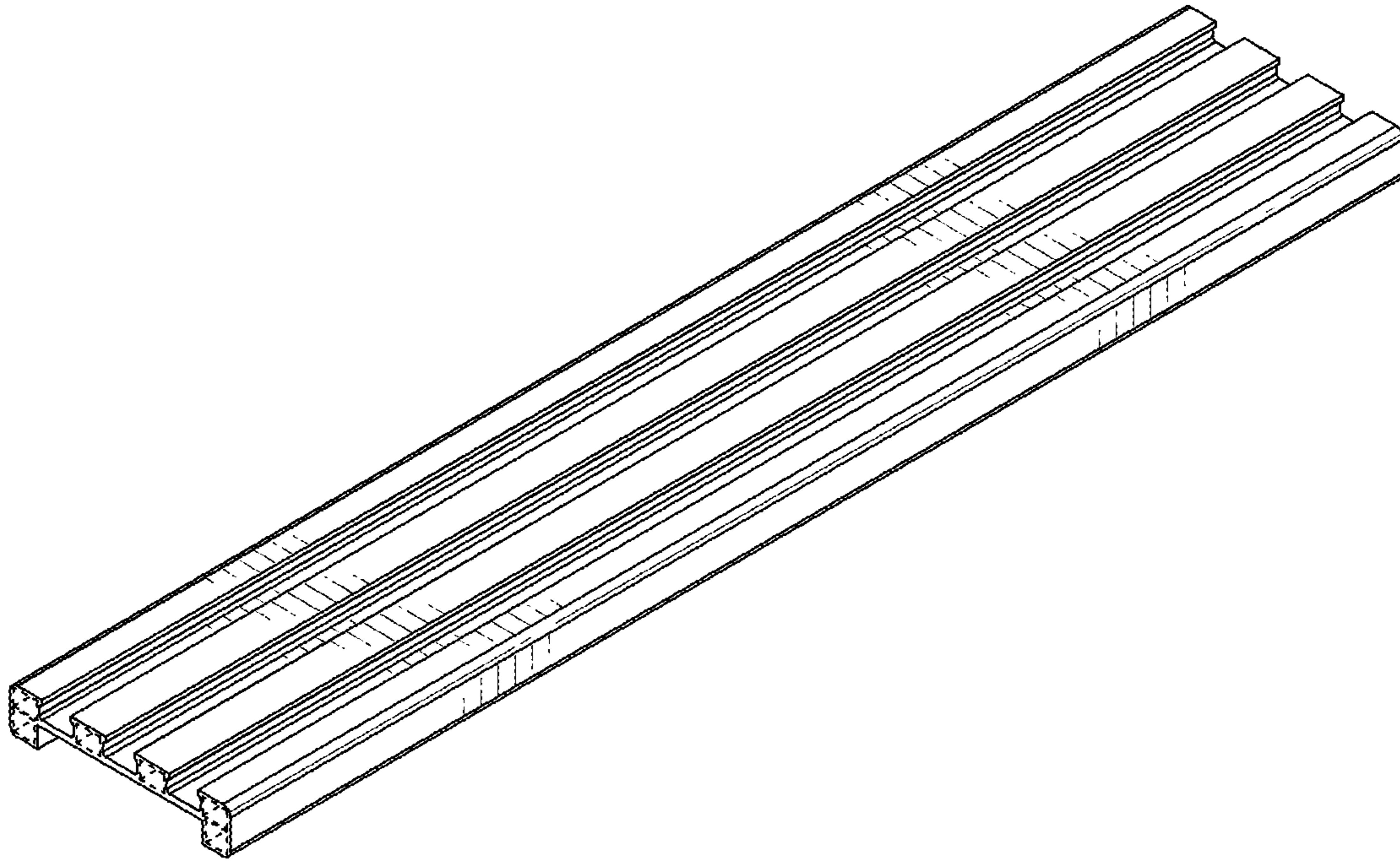

FIG.1

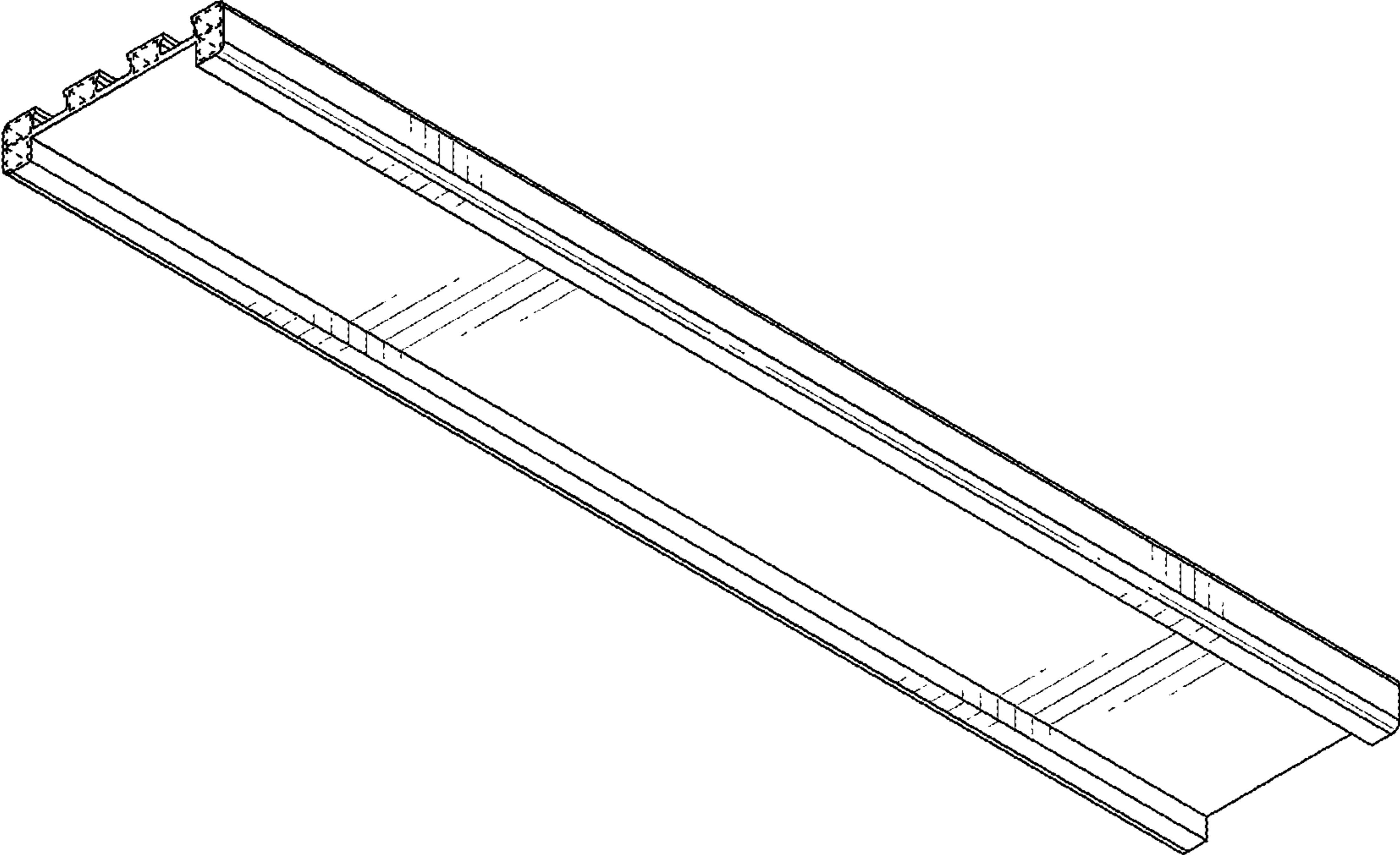

FIG.2

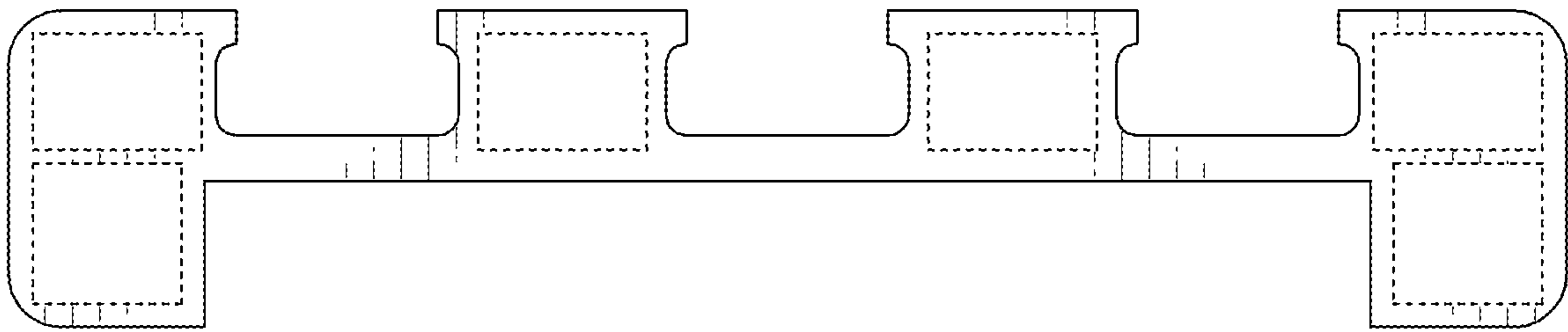

FIG.3

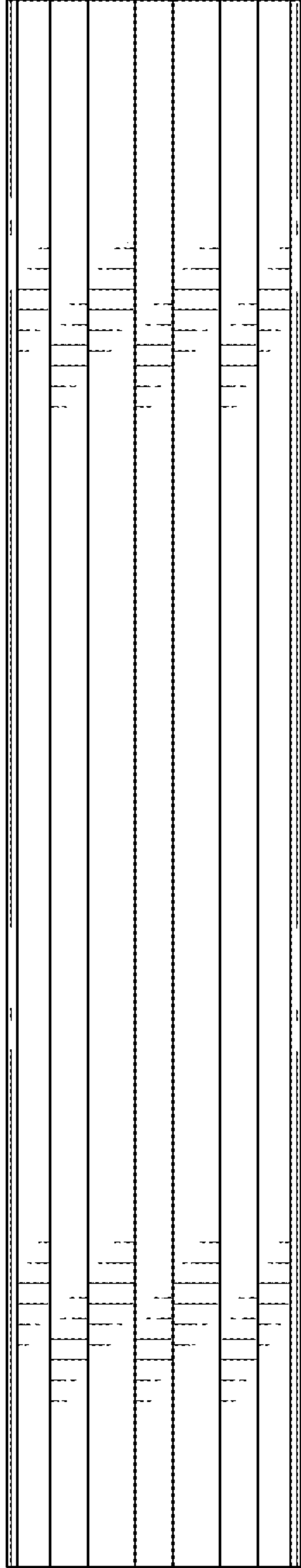

FIG.4



FIG.5