



US00D898638S

(12) **United States Design Patent** (10) **Patent No.:** **US D898,638 S**  
**Maple** (45) **Date of Patent:** **\*\* Oct. 13, 2020**

(54) **AIR INLET WITH INTEGRATED FLUID DIVERTER**

(71) Applicant: **Textron Aviation Inc.**, Wichita, KS (US)

(72) Inventor: **Raymond Charters Maple**, Wichita, KS (US)

(73) Assignee: **Textron Innovations, Inc.**, Providence, RI (US)

(\*\*) Term: **15 Years**

(21) Appl. No.: **29/640,411**

(22) Filed: **Mar. 14, 2018**

(51) **LOC (12) Cl.** ..... **12-16**

(52) **U.S. Cl.**  
USPC ..... **D12/181**

(58) **Field of Classification Search**  
USPC ..... D12/181, 182, 183, 184, 191, 400  
CPC ..... B60S 9/205; B32B 3/00  
See application file for complete search history.

(56) **References Cited**

U.S. PATENT DOCUMENTS

5,779,189	A	7/1998	Hamstra et al.	
6,634,595	B2	10/2003	Koncsek et al.	
D659,059	S *	5/2012	Elmitt	D12/190
8,393,566	B2	3/2013	Siercke et al.	
D717,222	S *	11/2014	Waterman	D12/190
D748,547	S *	2/2016	Battams	D12/190
D763,152	S *	8/2016	Frascella	D12/190
D796,404	S *	9/2017	Nurnberger	D12/181
9,862,482	B2	1/2018	Huynh et al.	
D829,624	S *	10/2018	Jamieson	D12/196

D835,551	S *	12/2018	DiCanzio	D12/173
D848,331	S *	5/2019	Nurnberger	D12/190
D849,616	S *	5/2019	Nurnberger	D12/190
D873,192	S *	1/2020	Smith	D12/190
D885,271	S *	5/2020	Lu	D12/181
2008/0036222	A1 *	2/2008	Iwamoto	F01N 13/082 293/113
2013/0313032	A1 *	11/2013	Fiello	F02M 35/048 180/68.3

\* cited by examiner

Primary Examiner — Katrina A Betton

(74) Attorney, Agent, or Firm — Erise IP, P.A.

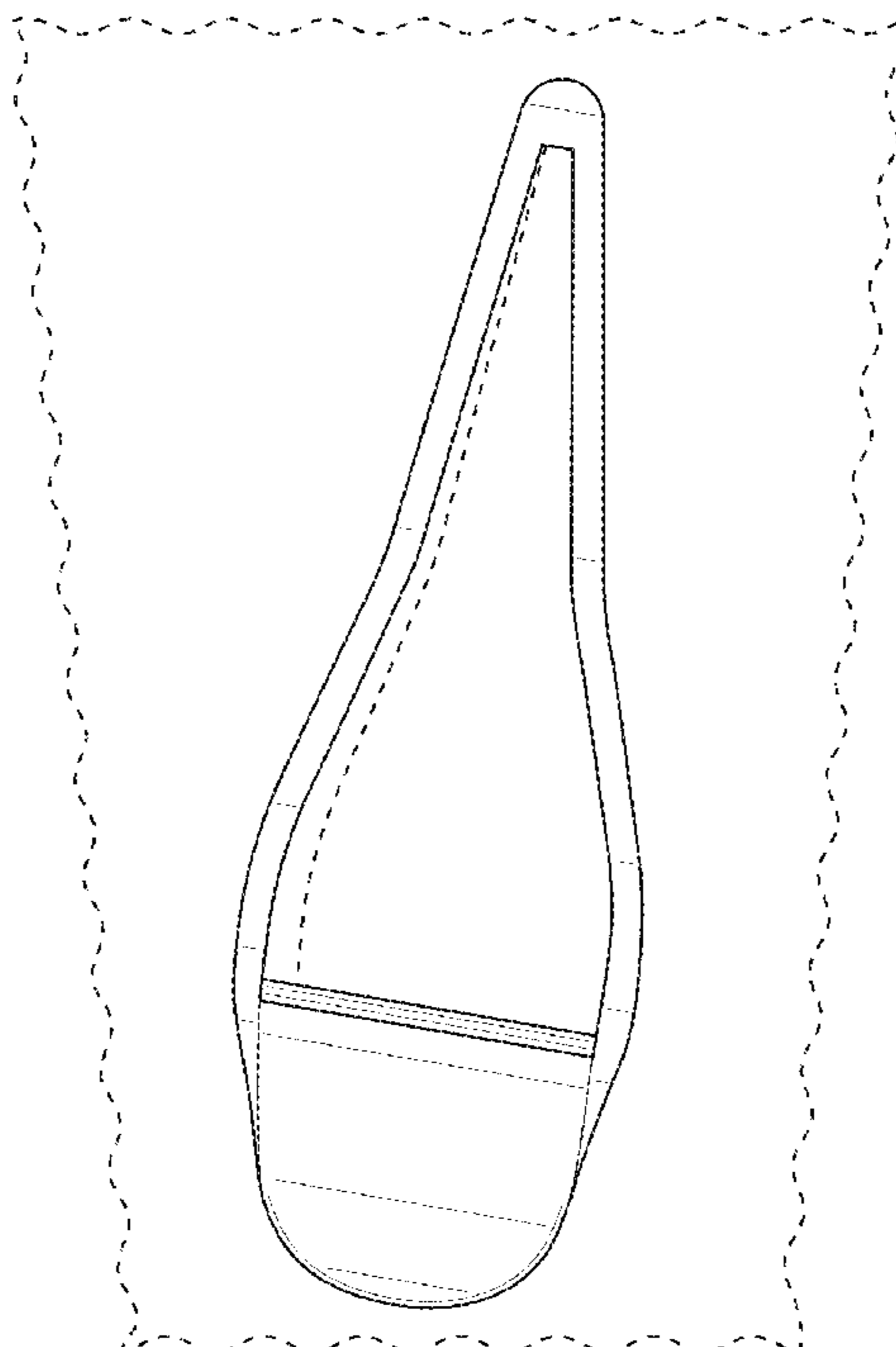
(57) **CLAIM**

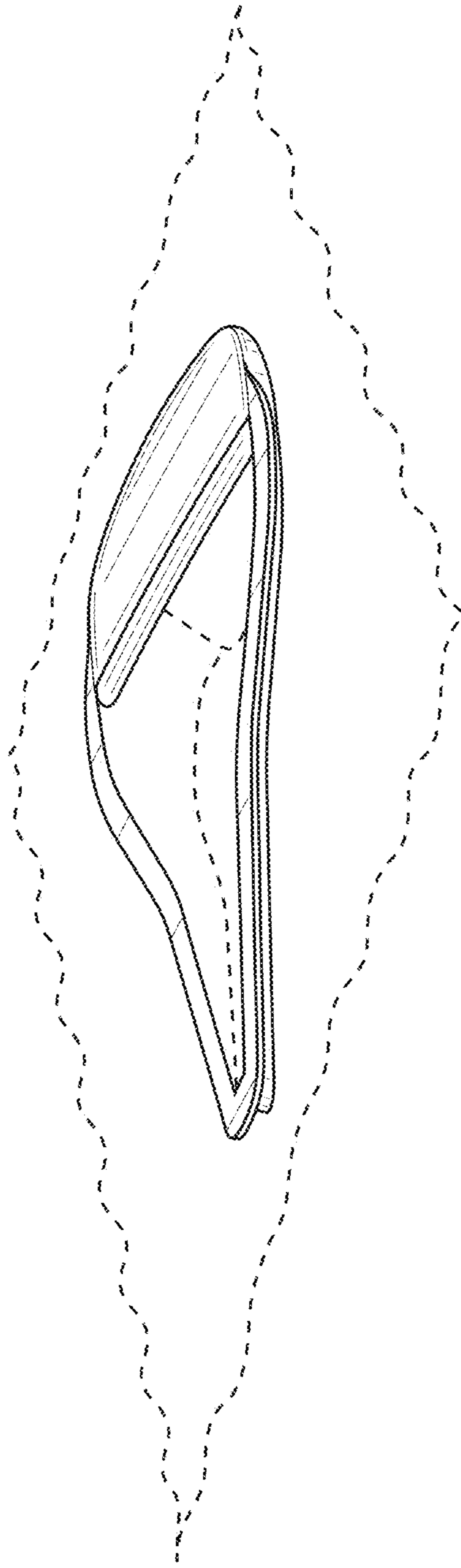
The ornamental design for a air inlet with integrated fluid diverter, as shown and described.

**DESCRIPTION**

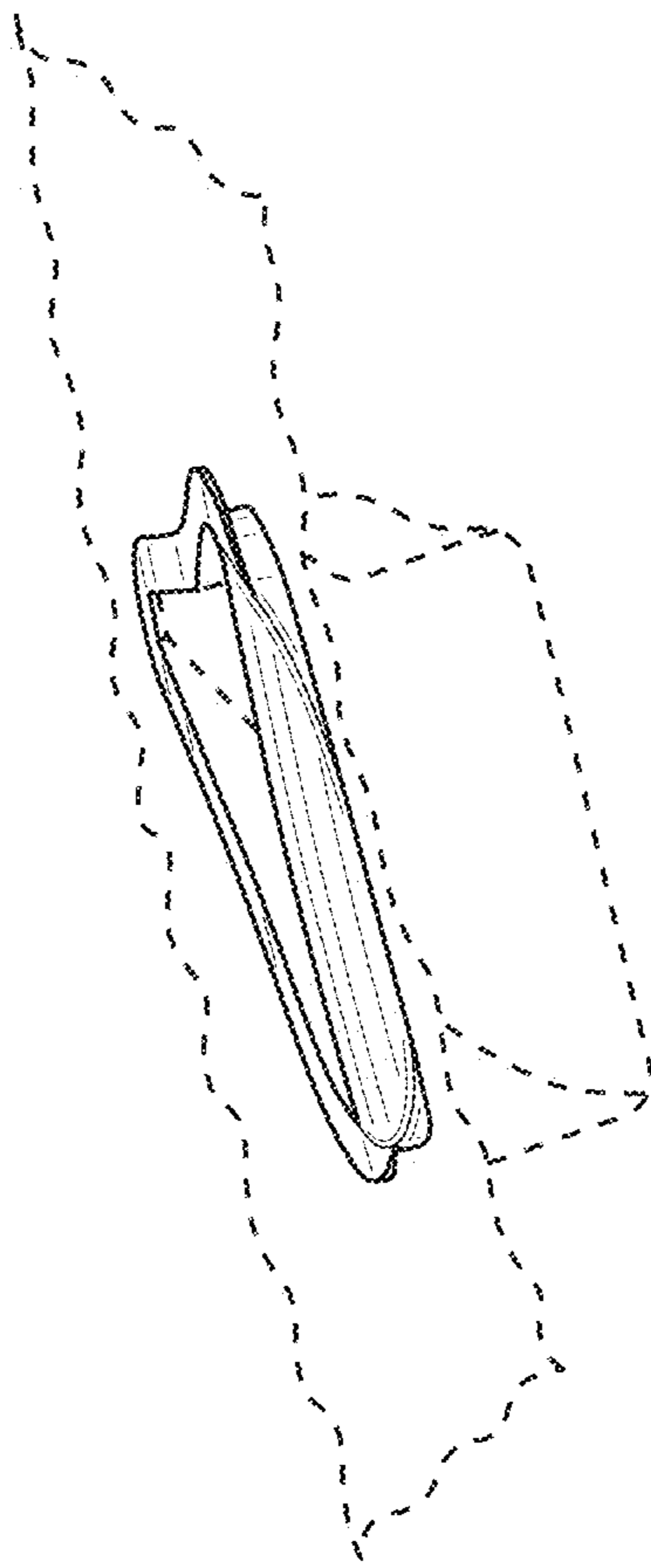
FIG. 1 is a front perspective view of an air inlet with an integrated fluid diverter from above;  
 FIG. 2 is a rear perspective view of the air inlet with an integrated fluid diverter;  
 FIG. 3 is a front perspective view of the air inlet with an integrated fluid diverter from below;  
 FIG. 4 is a side perspective view of the air inlet with an integrated fluid diverter from the right;  
 FIG. 5 is a bottom side view of the air inlet with an integrated fluid diverter from the left;  
 FIG. 6 is a top view of the air inlet with an integrated fluid diverter; and,  
 FIG. 7 is a bottom view of the air inlet with an integrated fluid diverter.  
 In FIGS. 1-7, broken lines indicate environmental structure that forms no part of the claimed design.

**1 Claim, 7 Drawing Sheets**

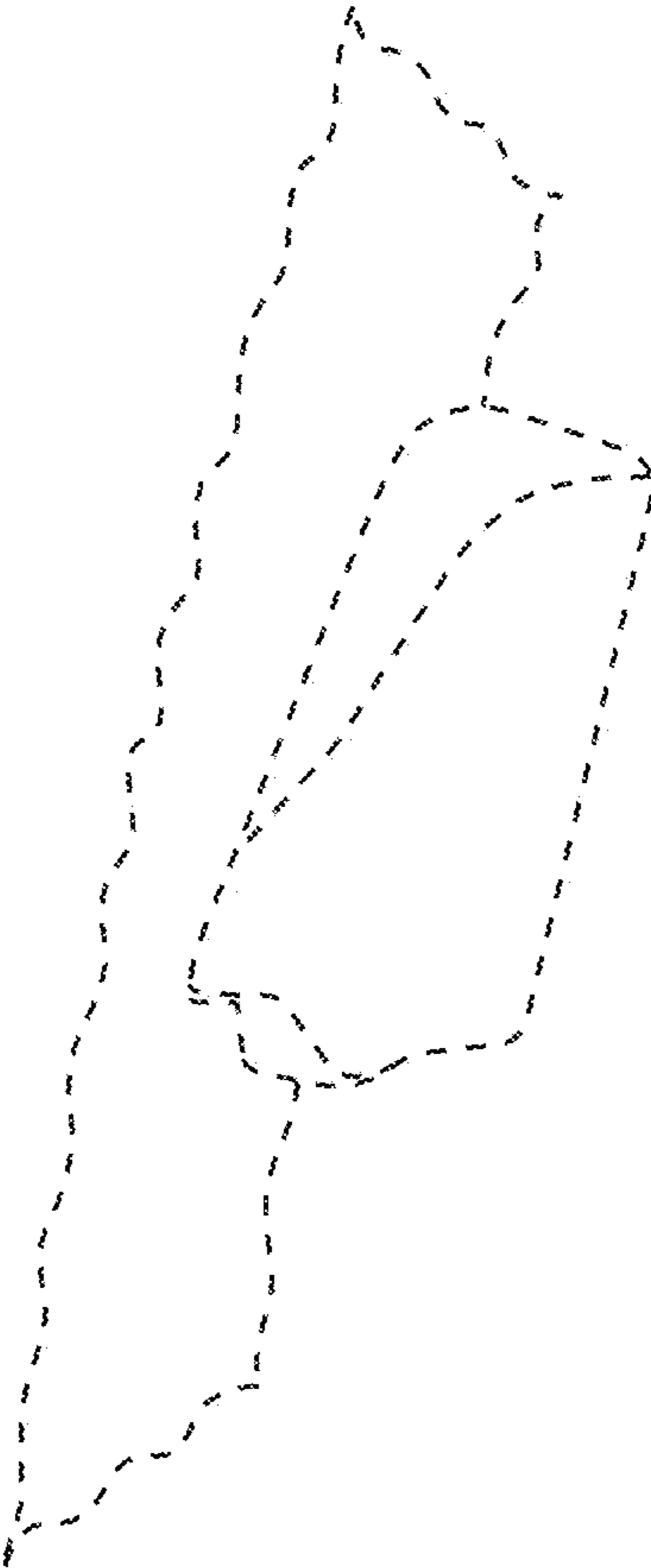




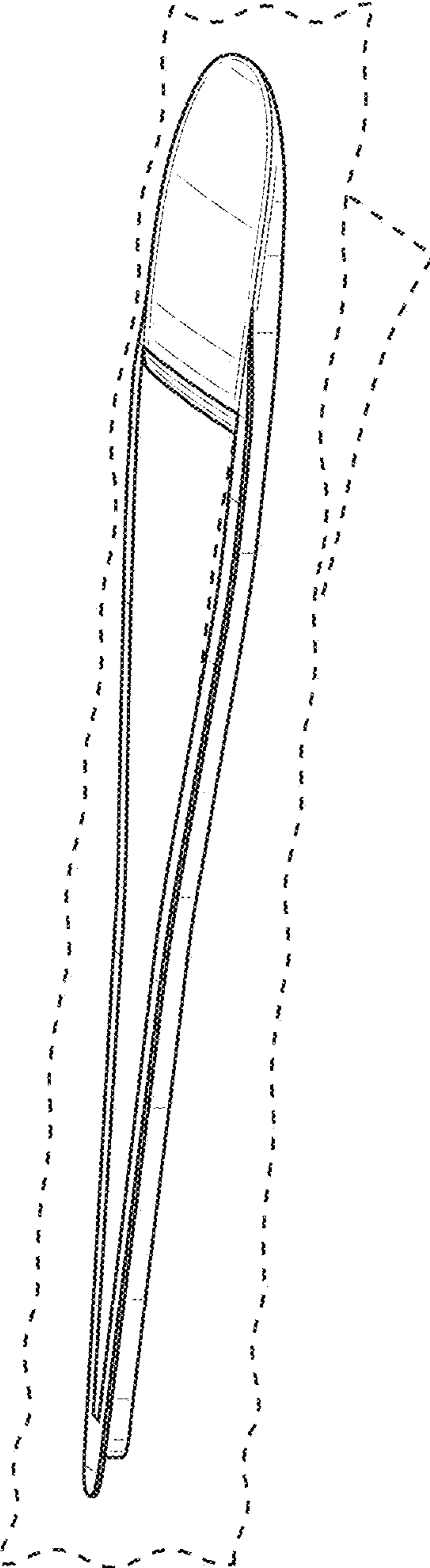
**FIG. 1**



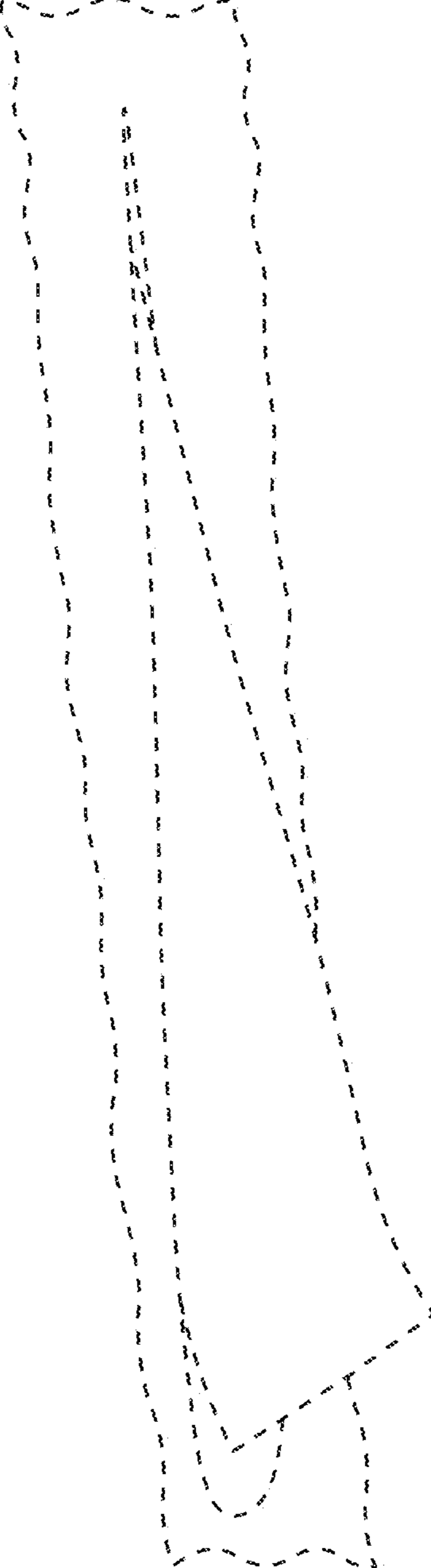
**FIG. 2**



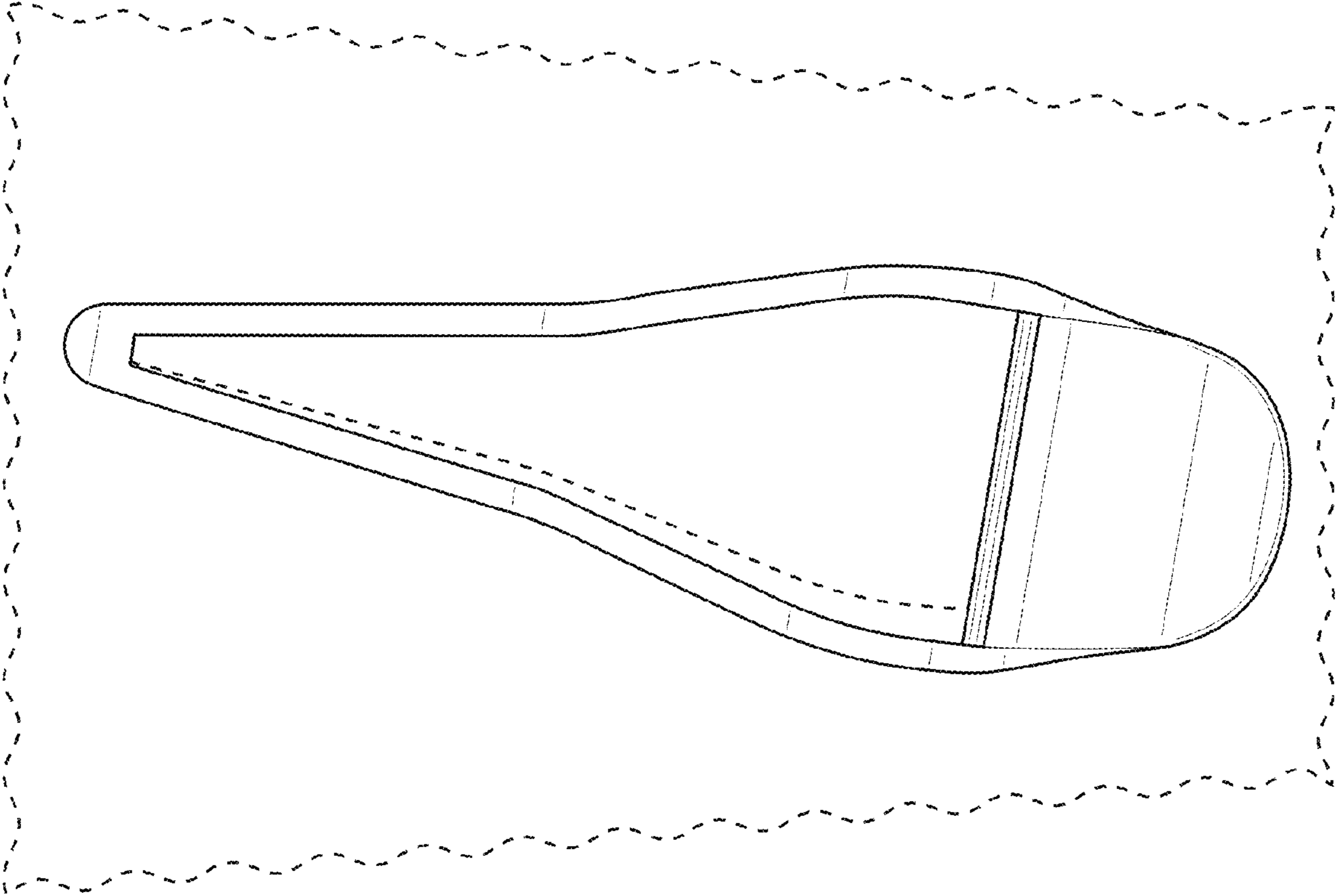
**FIG. 3**



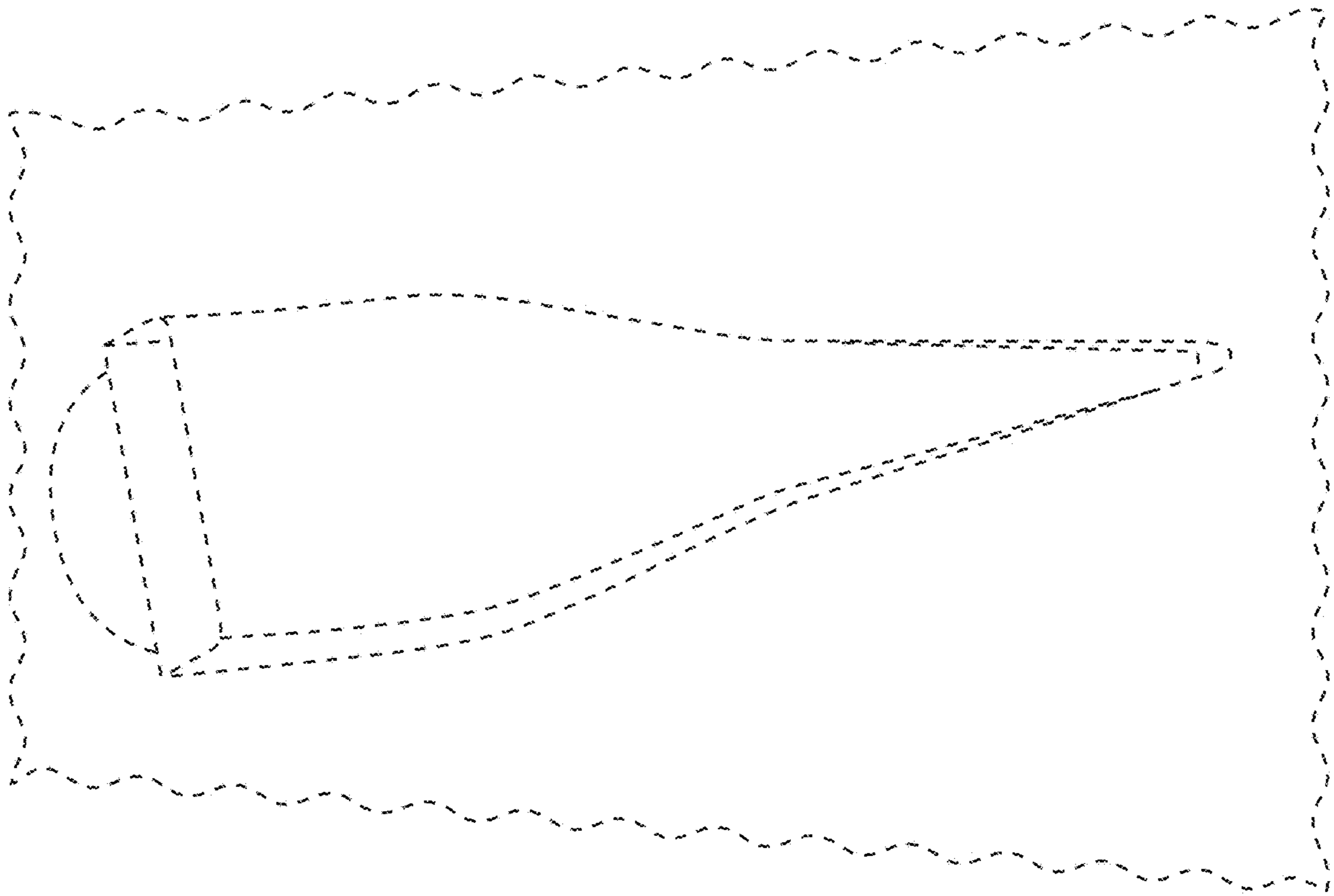
**FIG. 4**



**FIG. 5**



**FIG. 6**



**FIG. 7**