



US00D898559S

(12) **United States Design Patent** (10) **Patent No.:** **US D898,559 S**  
**Hill** (45) **Date of Patent:** **\*\* Oct. 13, 2020**

(54) **DECORATIVE STRUCTURAL CONNECTOR**

D30,898 S 5/1899 Paine  
933,865 A 9/1909 Umholtz  
964,827 A 7/1910 Whitmore  
974,637 A 11/1910 Borup  
(Continued)

(71) Applicant: **Oz-Post International, LLC**,  
Richardson, TX (US)

(72) Inventor: **Ian A. Hill**, Plano, TX (US)

(73) Assignee: **Oz-Post International, LLC**,  
Richardson, TX (US)

(\*\*) Term: **15 Years**

(21) Appl. No.: **29/703,732**

(22) Filed: **Aug. 29, 2019**

**FOREIGN PATENT DOCUMENTS**

CN 200985943 12/2007  
CN 201382063 1/2010  
(Continued)

**OTHER PUBLICATIONS**

Declaration of Fred P. Smith, P.E. in Support of Petition for Inter Partes Review of U.S. Pat. No. 9,957,998, *Simpson Strong-Tie Company Inc. v. Oz-Post International, LLC*, Jul. 20, 2018, 125 pages.  
(Continued)

*Primary Examiner* — Cynthia R Underwood  
(74) *Attorney, Agent, or Firm* — Foley & Lardner LLP

**Related U.S. Application Data**

(60) Continuation of application No. 15/933,959, filed on Mar. 23, 2018, now Pat. No. 10,520,007, which is a continuation of application No. 15/338,104, filed on Oct. 28, 2016, now Pat. No. 9,957,998, which is a continuation of application No. 14/820,757, filed on Aug. 7, 2015, now Pat. No. 9,771,966, which is a division of application No. 13/918,227, filed on Jun. 14, 2013, now Pat. No. 9,133,874.

(51) **LOC (12) Cl.** ..... **08-08**

(52) **U.S. Cl.**  
USPC ..... **D8/397**

(58) **Field of Classification Search**  
USPC ..... D8/397, 394, 382, 349; 411/427  
CPC ..... F16B 37/14; F16B 35/00; F16B 23/0061;  
F16B 41/002; A61B 17/0401; E04D  
13/1476  
See application file for complete search history.

(57) **CLAIM**

The ornamental design for a decorative structural connector, as shown and described.

**DESCRIPTION**

FIG. 1 is a perspective view of a decorative structural connector;  
FIG. 2 is a top plan view of the decorative structural connector shown in FIG. 1;  
FIG. 3 is a right side elevation view of the decorative structural connector shown in FIG. 1, the left side elevation view is a mirror image thereof; and,  
FIG. 4 a front elevation view of the decorative structural connector shown in FIG. 1, the rear elevation view is a mirror image thereof.  
The broken lines represent environment and form no part of the claim.

(56) **References Cited**

**U.S. PATENT DOCUMENTS**

111,996 A 2/1871 Washbourne  
153,500 A 7/1874 Seymour  
236,723 A 1/1881 Sellers  
529,683 A 11/1894 Herman

**1 Claim, 4 Drawing Sheets**

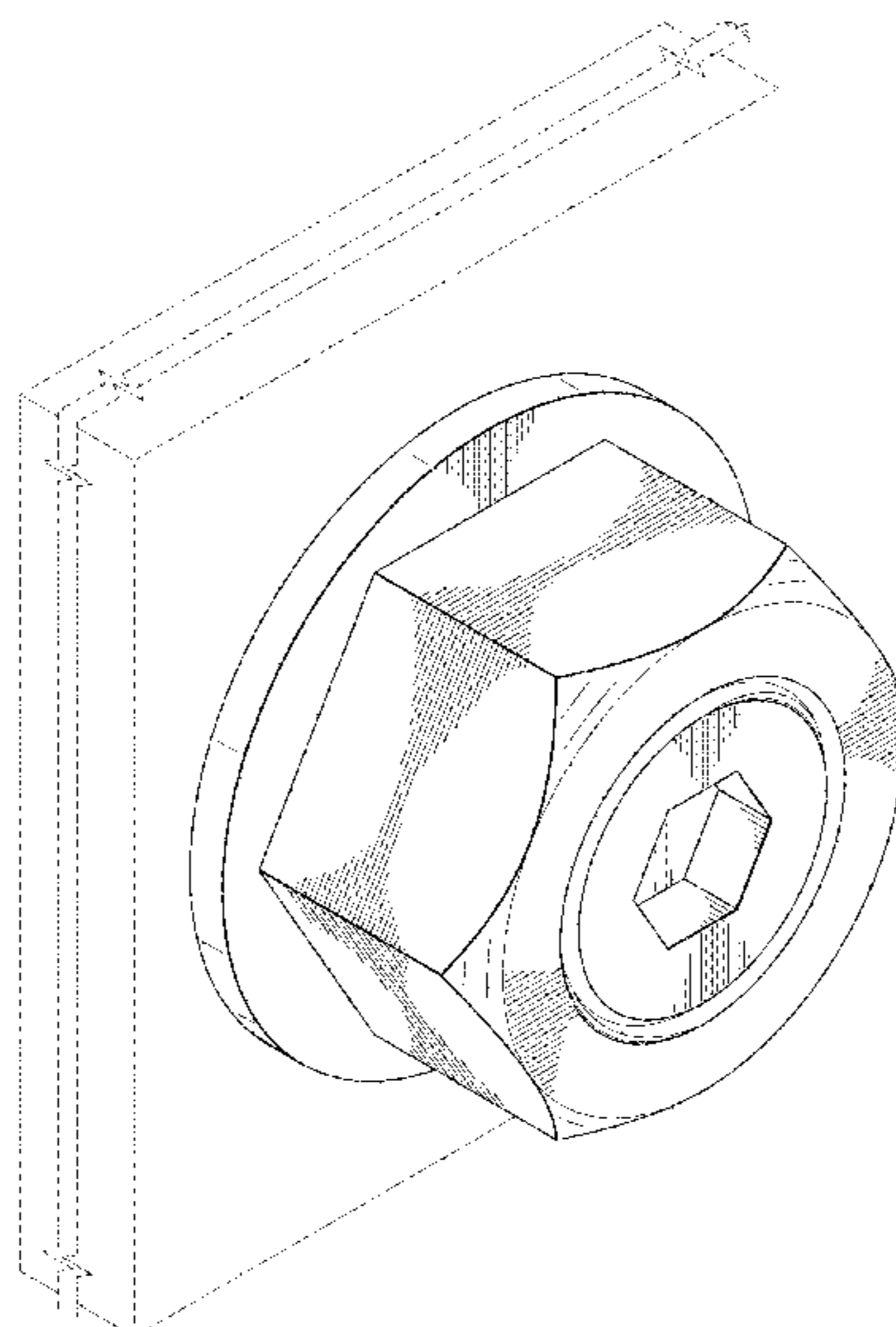

(56)

References Cited

U.S. PATENT DOCUMENTS

1,086,737 A	2/1914	Taylor		6,295,900 B1 *	10/2001	Julicher .....	B25B 13/485 411/910
1,162,467 A	11/1915	Fitz		6,309,158 B1	10/2001	Bellinghausen et al.	
1,368,222 A	2/1921	Foreman		D452,429 S	12/2001	Shinjo et al.	
1,374,963 A	4/1921	Stevenson		6,332,741 B1	12/2001	Janusz	
1,400,531 A	12/1921	Dodds		6,361,258 B1	3/2002	Heesch	
1,401,684 A	12/1921	Rogers et al.		6,387,129 B2	5/2002	Rieser et al.	
1,480,253 A	5/1923	Fisher		D459,207 S *	6/2002	Miyata .....	D8/397
1,506,005 A	8/1924	Kraft		6,457,923 B1	10/2002	Grossman	
1,507,840 A	9/1924	Landgraf		6,478,518 B1	11/2002	Hwang	
1,703,232 A	2/1929	Gray et al.		6,540,750 B2	4/2003	Burkhart	
1,908,080 A	5/1933	Thompson		6,764,114 B1	7/2004	Guillon	
1,994,978 A	3/1935	Brown		D512,886 S	12/2005	Christensen	
2,278,320 A	5/1941	Kath		D520,856 S *	5/2006	Osiecki .....	D8/312
2,316,695 A	4/1943	Jaffa		D524,149 S *	7/2006	Kim .....	D8/397
2,816,473 A	12/1957	Labee		D551,972 S *	10/2007	Jacobs .....	D9/445
3,042,068 A	7/1962	Smith		D552,977 S	10/2007	He et al.	
3,174,383 A	3/1965	Friedrich		D557,132 S *	12/2007	Shinjo .....	D8/397
3,204,586 A	9/1965	Marsh, Jr.		D567,074 S	4/2008	Gallien	
3,266,828 A	8/1966	Baier		7,384,225 B2	6/2008	Woolstencroft	
3,269,228 A	8/1966	Mack		D581,778 S	12/2008	Lesesky	
3,478,639 A	11/1969	Gruca		D588,893 S	3/2009	Radich	
3,492,841 A	2/1970	Ipri		D600,108 S *	9/2009	Swan .....	D8/397
D233,138 S	10/1974	Vogel		7,588,386 B2	9/2009	Kielczewski et al.	
3,851,978 A	12/1974	Kuipers		D602,349 S	10/2009	Andersson	
3,965,793 A	6/1976	Roser		D609,999 S	2/2010	Andersson	
4,033,243 A *	7/1977	Kirrish .....	F16B 37/145 411/338	7,658,580 B1	2/2010	Conway et al.	
4,092,896 A	6/1978	Puchy		D613,594 S	4/2010	Huang	
4,111,568 A	9/1978	Wing		D613,595 S	4/2010	Huang	
4,125,140 A	11/1978	Basile		D614,247 S	4/2010	Clausen	
4,134,438 A	1/1979	Frieberg et al.		7,981,143 B2	7/2011	Doubler et al.	
4,207,938 A	6/1980	Mortus		D643,279 S	8/2011	Crane et al.	
D256,553 S	8/1980	Fayle		D646,153 S	10/2011	Andersson	
4,242,932 A *	1/1981	Barmore .....	F16B 23/0092 411/403	D646,154 S	10/2011	Andersson	
4,274,754 A	6/1981	Cohen		8,051,690 B2	11/2011	Camisasca	
4,281,699 A	8/1981	Grube		D678,756 S	3/2013	Tsai	
4,436,005 A	3/1984	Hanson		D679,988 S	4/2013	Yamazaki	
D276,879 S	12/1984	Bell		8,506,199 B2	8/2013	Rump et al.	
D278,029 S *	3/1985	Suponitsky .....	D8/397	D691,033 S	10/2013	Allman	
4,540,322 A	9/1985	Coffia		D698,234 S	1/2014	Bauer	
4,601,624 A	7/1986	Hill		8,622,677 B2	1/2014	Wu et al.	
4,621,230 A	11/1986	Crouch et al.		D698,637 S	2/2014	Su	
4,631,887 A	12/1986	Francovitch		D706,126 S	6/2014	Orow	
4,632,616 A	12/1986	Sidoti		D713,243 S	9/2014	Hsu	
4,683,670 A	8/1987	Bates		D717,207 S *	11/2014	Fondas .....	D11/222
4,708,555 A	11/1987	Terry		D720,785 S	1/2015	Sato	
4,822,223 A	4/1989	Williams		D721,423 S	1/2015	Jacques et al.	
4,867,624 A	9/1989	Walley		D725,461 S	3/2015	Kopp	
4,887,951 A	12/1989	Hashimoto		9,004,836 B2 *	4/2015	Wells .....	F16B 23/0007 411/402
D311,131 S	10/1990	Saito		D733,546 S	7/2015	Balzhiser	
4,998,780 A	3/1991	Eshler et al.		D735,076 S *	7/2015	Fondas .....	D11/222
5,030,052 A	7/1991	Anderson et al.		9,377,047 B2 *	6/2016	Hill .....	F16B 21/00
5,175,665 A	12/1992	Pegg		D760,582 S	7/2016	Muzic	
5,302,069 A	4/1994	Toth et al.		D788,574 S	6/2017	Baiz et al.	
5,433,570 A	7/1995	Koppel		D798,701 S	10/2017	Hill	
5,443,582 A	8/1995	Ching		D803,040 S	11/2017	Schuit et al.	
5,626,449 A	5/1997	McKinlay		D805,882 S *	12/2017	Berry .....	D8/382
5,651,651 A	7/1997	Spencer		D813,027 S *	3/2018	Wright .....	D8/397
5,697,746 A	12/1997	Brown et al.		9,957,998 B2	5/2018	Hill	
5,728,136 A	3/1998	Thal		D821,859 S *	7/2018	Artino .....	D8/387
5,769,144 A *	6/1998	Carter .....	A47H 13/02 160/330	D832,184 S *	10/2018	Woolstencroft .....	D12/400
5,782,078 A	7/1998	Brantley		D856,126 S *	8/2019	Liu .....	D8/397
5,904,383 A	5/1999	Van Der Wal		D864,125 S *	10/2019	Selig .....	D13/156
5,927,921 A	7/1999	Hukari		D870,545 S *	12/2019	Hill .....	F16B 37/14 D8/387
5,950,506 A *	9/1999	Busse .....	B25B 13/485 411/402	D871,201 S *	12/2019	Shinjo .....	D8/397
D416,192 S	11/1999	Tu		D878,194 S *	3/2020	Lee .....	D8/397
6,039,140 A	3/2000	Painter		10,612,581 B2 *	4/2020	Rajewski .....	F16B 41/005
D422,202 S *	4/2000	Maki .....	D8/387	2002/0197132 A1	12/2002	Cruz et al.	
6,045,312 A	4/2000	Hsing		2003/0165371 A1 *	9/2003	Notaro .....	F16B 23/0007 411/402
6,053,683 A	4/2000	Cabiran		2004/0170487 A1	9/2004	Thompson	
D432,006 S *	10/2000	Hussaini .....	D8/29	2005/0053446 A1	3/2005	Huang et al.	
6,220,804 B1	4/2001	Pamer et al.		2009/0108149 A1	4/2009	Goto	
				2009/0129887 A1 *	5/2009	Chang .....	B25B 13/485 411/402



(56)

References Cited

OTHER PUBLICATIONS

U.S. PATENT DOCUMENTS

2010/0172718	A1	7/2010	Gong et al.	
2010/0196119	A1	8/2010	Miyagawa et al.	
2011/0121152	A1	5/2011	Ghatikar	
2011/0170983	A1	7/2011	Day et al.	
2011/0214461	A1	9/2011	Camisasca	
2011/0226096	A1	9/2011	Berton et al.	
2011/0250035	A1	10/2011	Goldberg et al.	
2012/0219380	A1*	8/2012	Hutter, III	B64D 45/02 411/377
2013/0089388	A1	4/2013	Liu et al.	
2013/0136557	A1	5/2013	Wang	
2014/0023457	A1	1/2014	Gaudron et al.	
2014/0178150	A1	6/2014	Su et al.	
2014/0341649	A1	11/2014	Bryan et al.	
2015/0071731	A1	3/2015	Scheerer	
2015/0093213	A1	4/2015	Scheerer	
2016/0238054	A1	8/2016	Lehtola	
2016/0273573	A1	9/2016	Hill	
2017/0108026	A1	4/2017	Yang	
2017/0138386	A1	5/2017	Hsu	
2017/0282236	A1	10/2017	Hutter, III	
2017/0284447	A1	10/2017	Falkenstein et al.	

FOREIGN PATENT DOCUMENTS

KR	200169430	11/1999
KR	200183592	3/2000
WO	WO-92/07198	4/1992

English machine translation of previously cited Chinese Publication No. 21382063; translation provided to Applicant Jun. 19, 2019; 9 pages.

English translation and certificate of translation of previously cited Chinese Publication No. 200985943; translation provided to Applicant Jun. 19, 2019; 14 pages.

Expert Report of Fred P. Smith, *Simpson Strong-Tie Company Inc. v. Oz-Post International, LLC*, Case No. 3:18-cv-01188-WHO, Jun. 19, 2019, 99 pages.

Fournier, Ron et al., "HPBooks: Metal Fabricator's Handbook", The Berkley Publishing Group, p. 15.

Petition for Inter Partes Review of U.S. Pat. No. 9,957,998, *Simpson Strong-Tie Company Inc. v. Oz-Post International, LLC*, Jul. 23, 2018, 84 pages.

Precision Metalforming Association, Design Guidelines for Precision Metalforming: Metal Stamping, Fabrication, Metal Spinning, Roll Forming, Secondary Operations and Related Subjects, "Spot Welding", Fourth Edition, 2009, pp. 115-122.

Simpson Strong-Tie Company, Inc.'s Invalidity Contentions Pursuant to Patent Local Rule 3-3, *Simpson Strong-Tie Company Inc. v. Oz-Post International, LLC*, Mar. 23, 2018, 458 pages.

Steel 2 Wood Fence Bracket WAP OZ, video post date: Jun. 17, 2014 (online), <https://www.homedepot.com/p/Oz-Post-Steel-2-Wood-Fence-Bracket-WAP-OZ-50110/204675163>.

Supplemental Expert Report of Fred P. Smith, *Simpson Strong-Tie Company Inc. v. Oz-Post International, LLC*, Case No. 3:18-cv-01188-WHO, Jul. 16, 2020, 236 pages.

\* cited by examiner

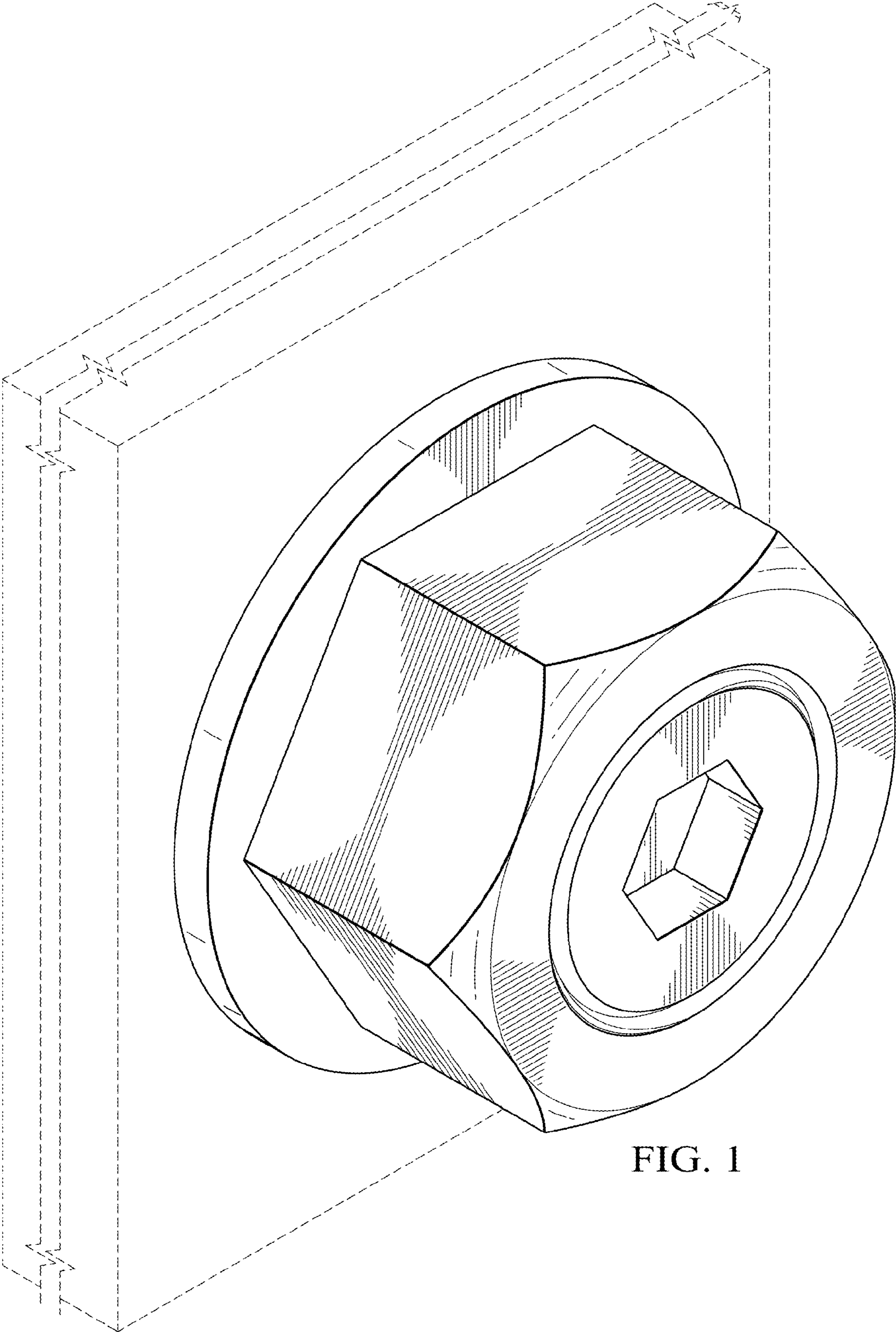

FIG. 1

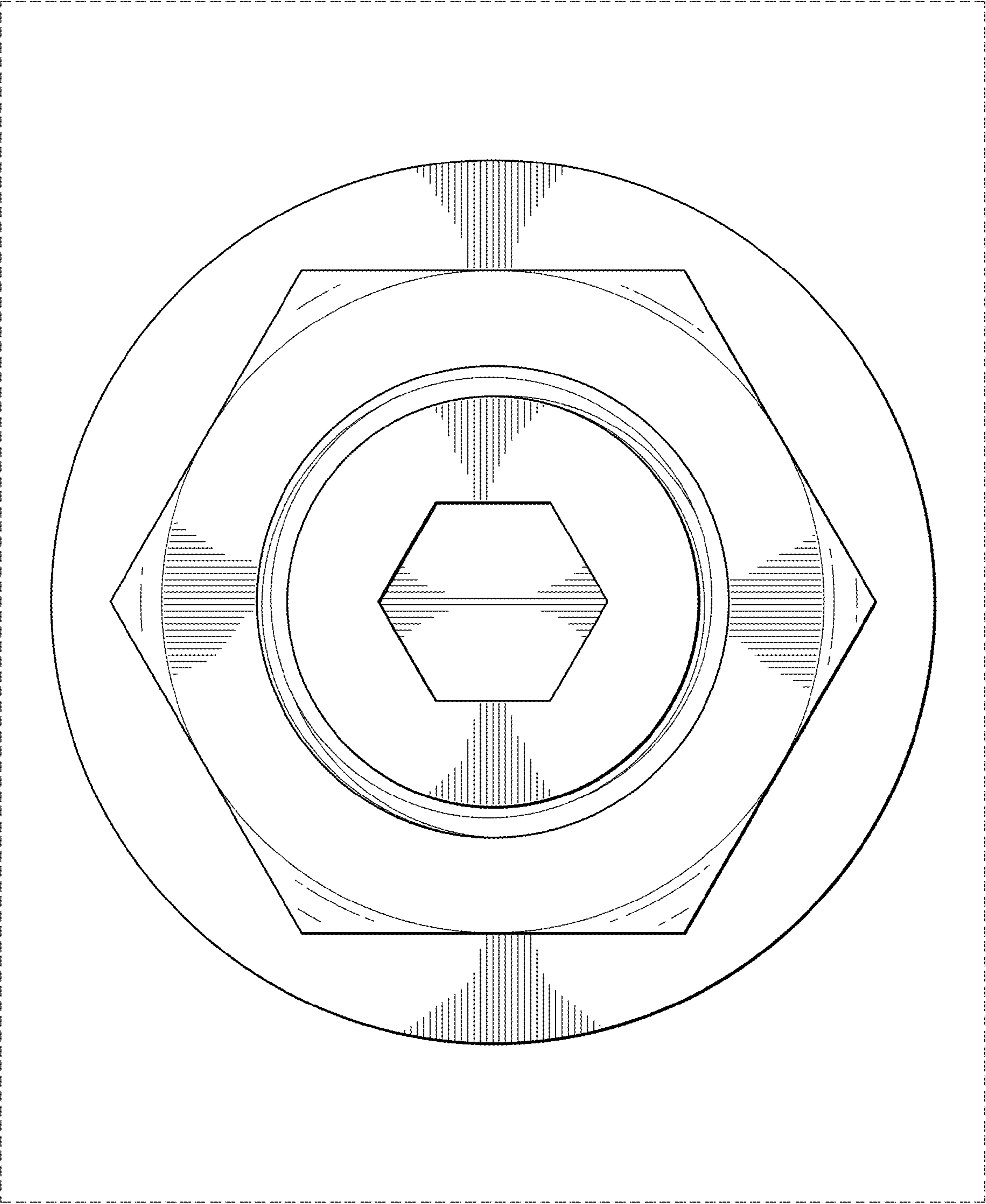

FIG. 2

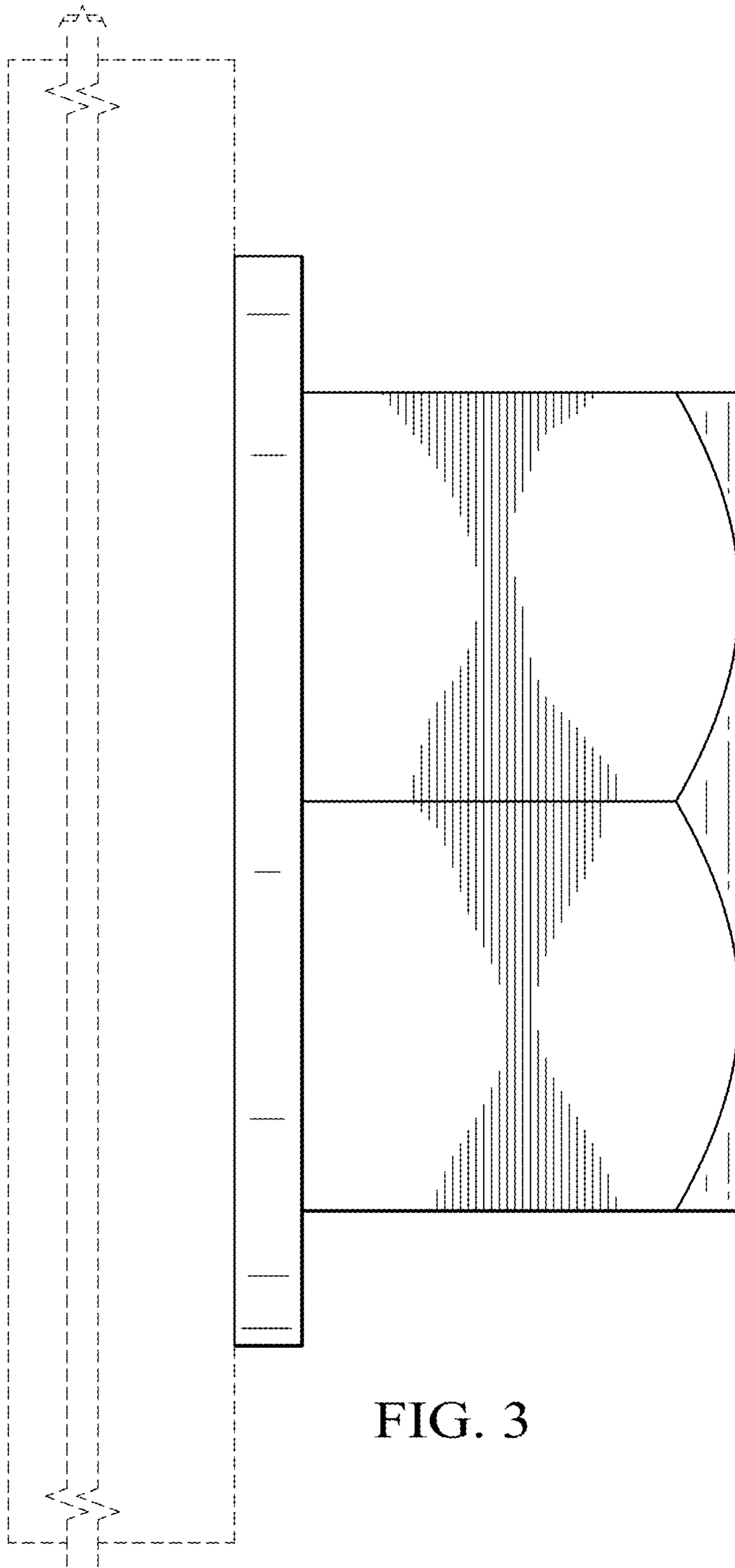

FIG. 3



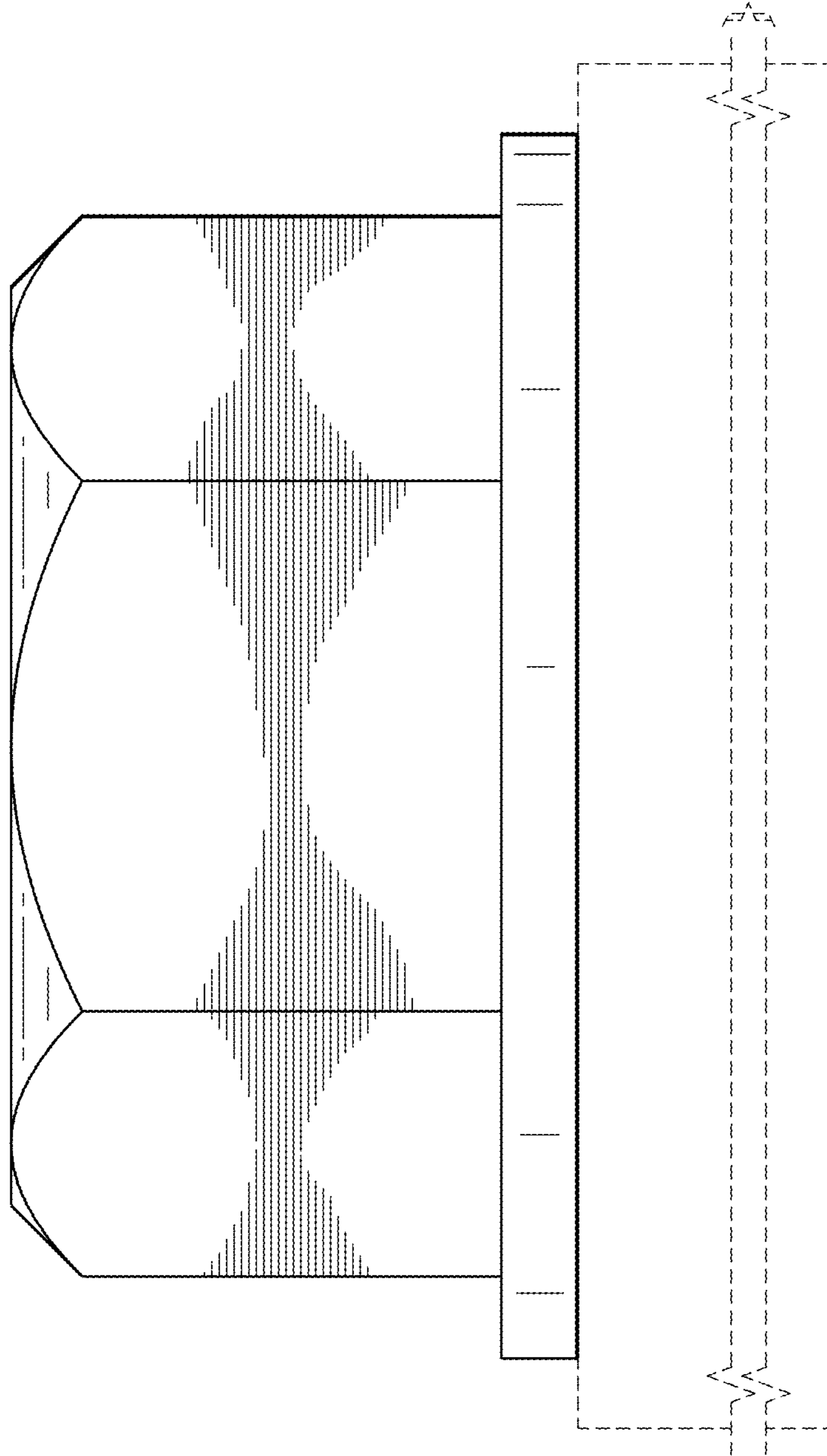

FIG. 4