



US00D897573S

(12) **United States Design Patent** (10) **Patent No.:** **US D897,573 S**  
**Patel** (45) **Date of Patent:** **\*\* Sep. 29, 2020**

(54) **HEADLIGHT**

(71) Applicant: **Jaguar Land Rover Limited**, Whitley, Coventry (GB)

(72) Inventor: **Paven Patel**, Whitley Coventry (GB)

(73) Assignee: **Jaguar Land Rover Limited**, Whitley Coventry (GB)

(\*\*) Term: **15 Years**

(21) Appl. No.: **29/687,351**

(22) Filed: **Apr. 12, 2019**

(30) **Foreign Application Priority Data**

Oct. 25, 2018 (EM) ..... 005808458

(51) **LOC (12) Cl.** ..... **26-06**

(52) **U.S. Cl.**  
USPC ..... **D26/28**

(58) **Field of Classification Search**  
USPC ..... D26/28-36, 139  
CPC ..... F21S 48/00; F21S 48/10; F21S 48/115;  
F21S 48/225; F21S 48/1233; F21S  
48/1266; F21S 48/1388; F21S 48/2268;  
F21V 21/04; F21V 29/004; B60Q 9/13;  
B60Q 9/135; B60Q 9/1375  
See application file for complete search history.

(56) **References Cited**

**U.S. PATENT DOCUMENTS**

D474,290 S \* 5/2003 Sawai ..... D26/28  
D549,858 S \* 8/2007 Pfeiffer ..... D26/28

D552,772 S \* 10/2007 Davidson ..... D26/28  
D586,010 S \* 2/2009 Saracoglu ..... D26/28  
D592,332 S \* 5/2009 Hsu ..... D26/28

\* cited by examiner

*Primary Examiner* — Marcus A Jackson  
(74) *Attorney, Agent, or Firm* — Wood Herron & Evans  
LLP

(57) **CLAIM**

The ornamental design for a headlight, as shown and described.

**DESCRIPTION**

FIG. 1 is a front left elevated perspective view of a headlight according to the present invention.

FIG. 2 is a front left perspective view of the headlight shown in FIG. 1.

FIG. 3 is a rear right elevated perspective view thereof.

FIG. 4 is a rear right perspective view thereof.

FIG. 5 is a front view thereof.

FIG. 6 is a rear view thereof.

FIG. 7 is a left side view thereof.

FIG. 8 is a right side view thereof.

FIG. 9 is a top view thereof.

FIG. 10 is a bottom view thereof; and,

FIG. 11 is a front view of the headlight shown in FIGS. 1-10, but with the headlight mounted on a vehicle, and the rest of the vehicle shown in de-emphasized and half-tone portions so as to illustrate environmental structure. These portions form no part of the claimed design. More particularly, in FIG. 11, the inventive headlight is shown within the broken line, and the elements shown outside the broken line form no part of the claimed design, but are instead included to show environmental aspects thereof. The present invention contemplates a mirror image headlight on the opposite side of the vehicle.

**1 Claim, 11 Drawing Sheets**

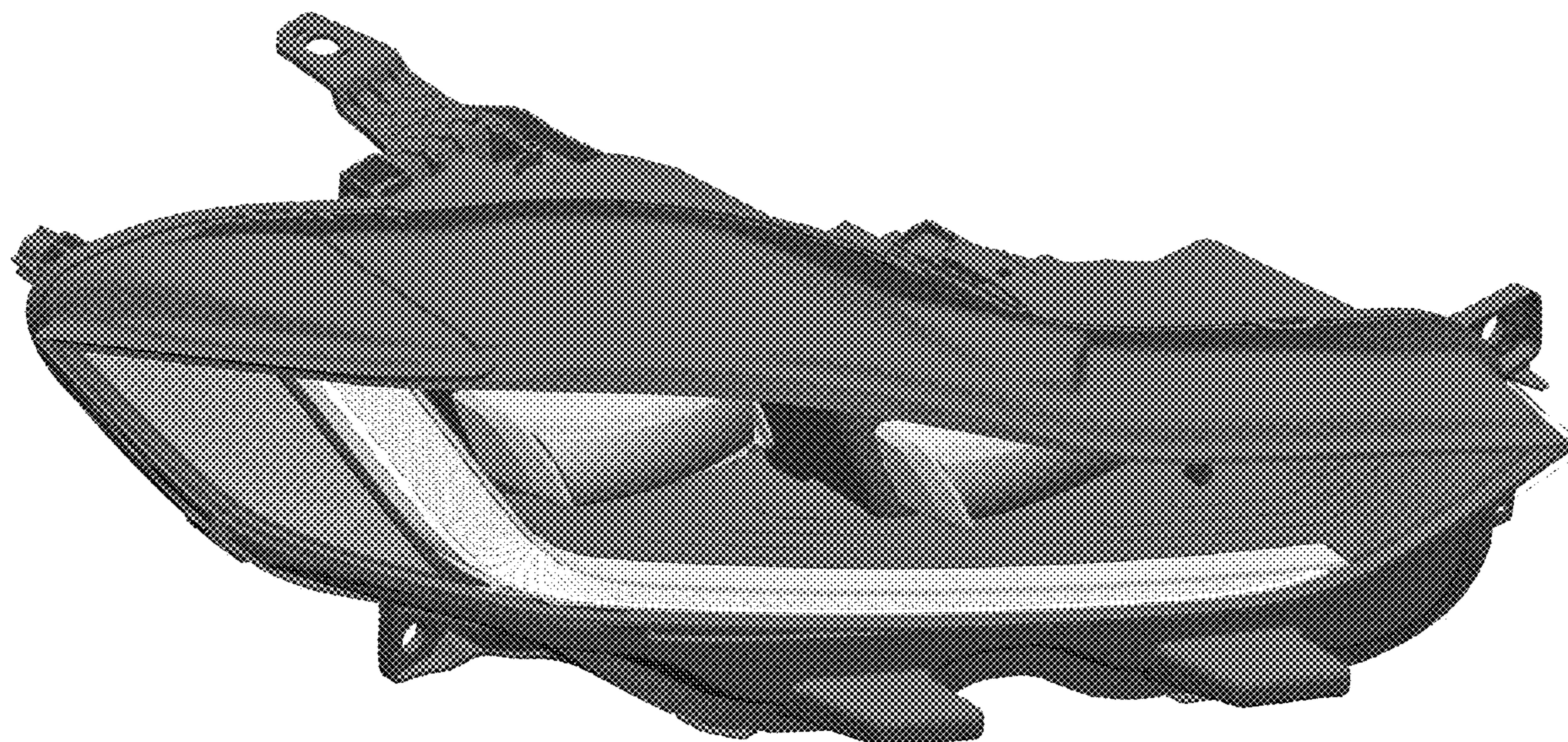

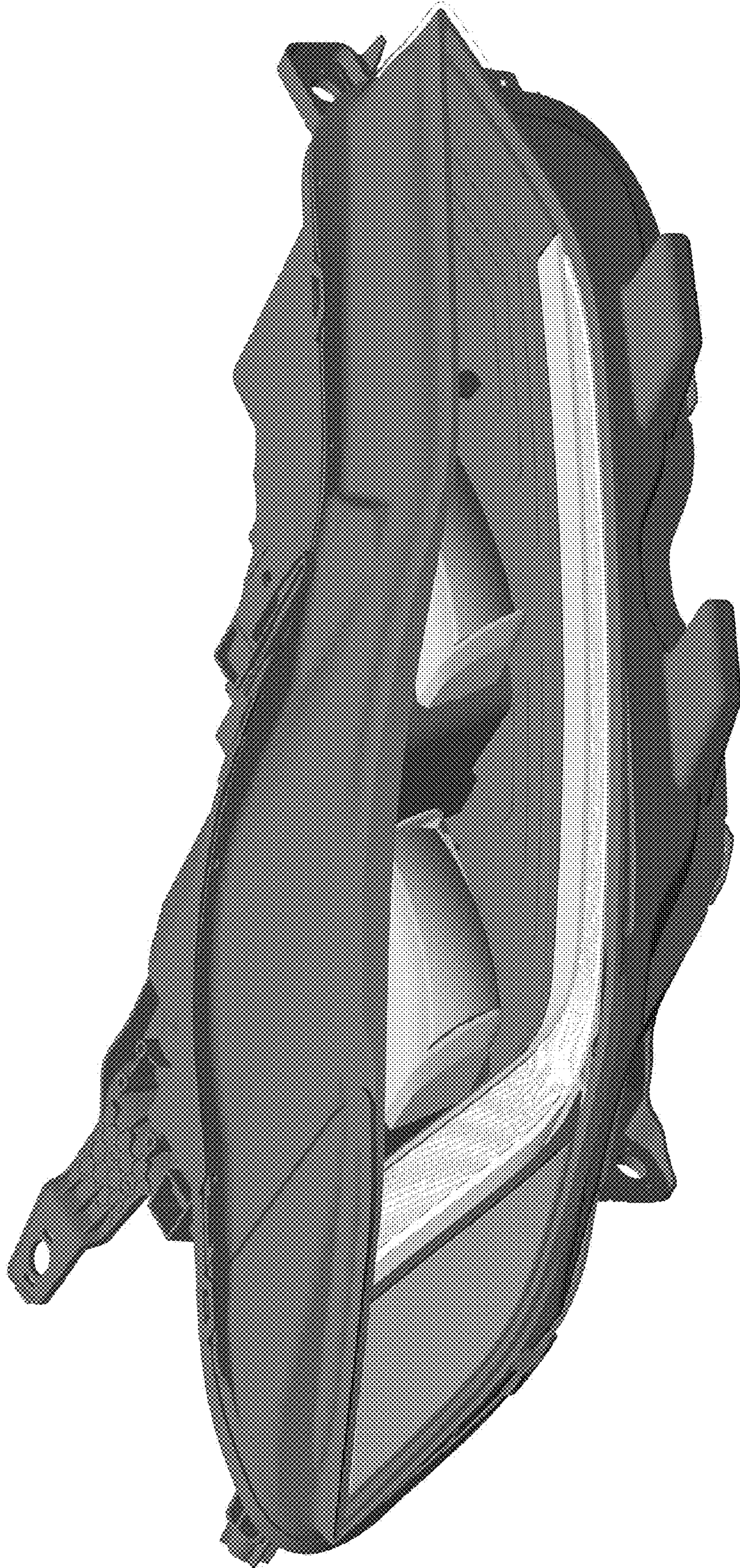

FIG. 1

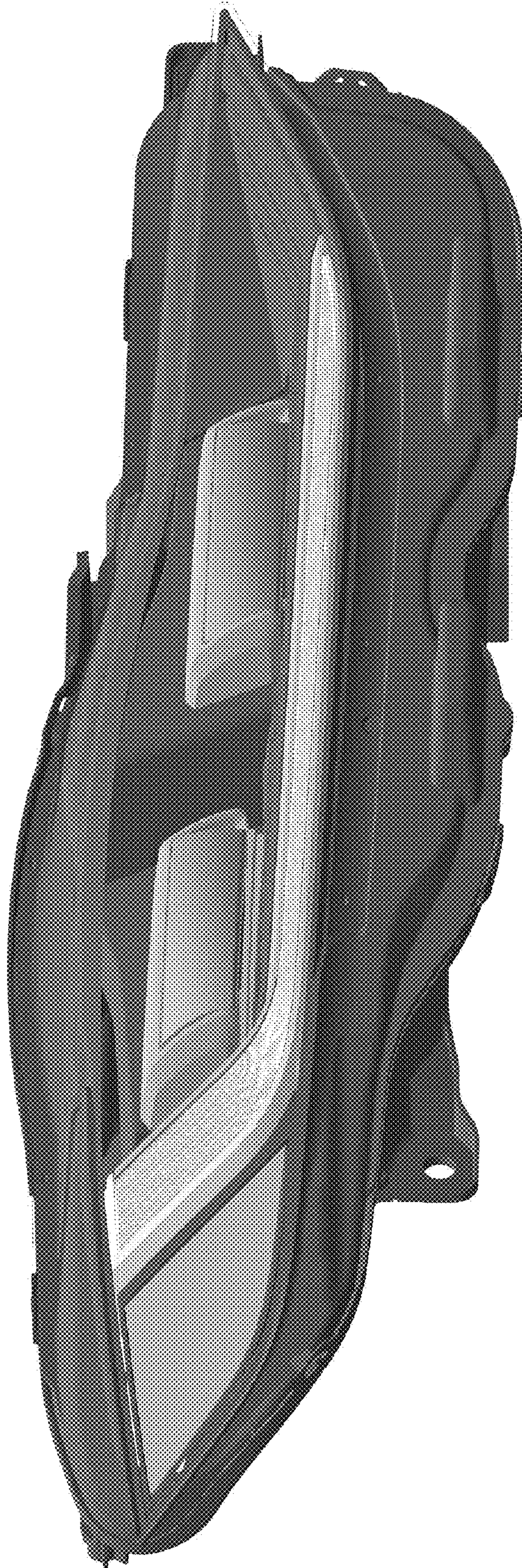

FIG. 2

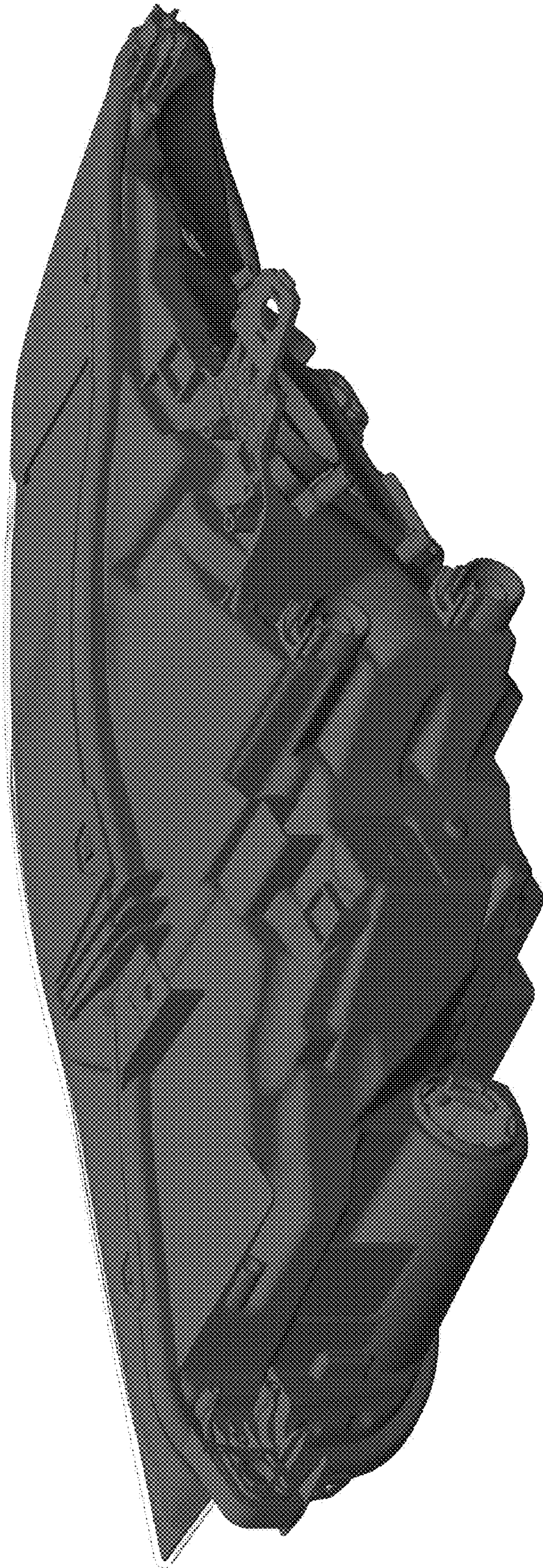

FIG. 3

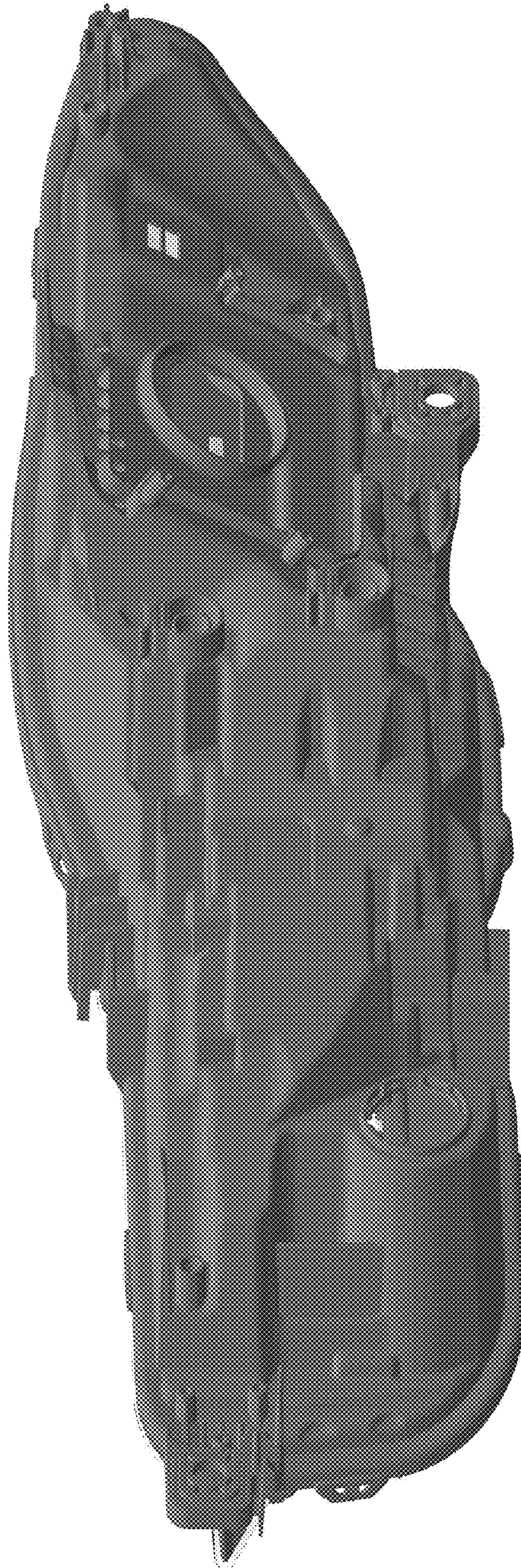

FIG. 4



FIG. 5

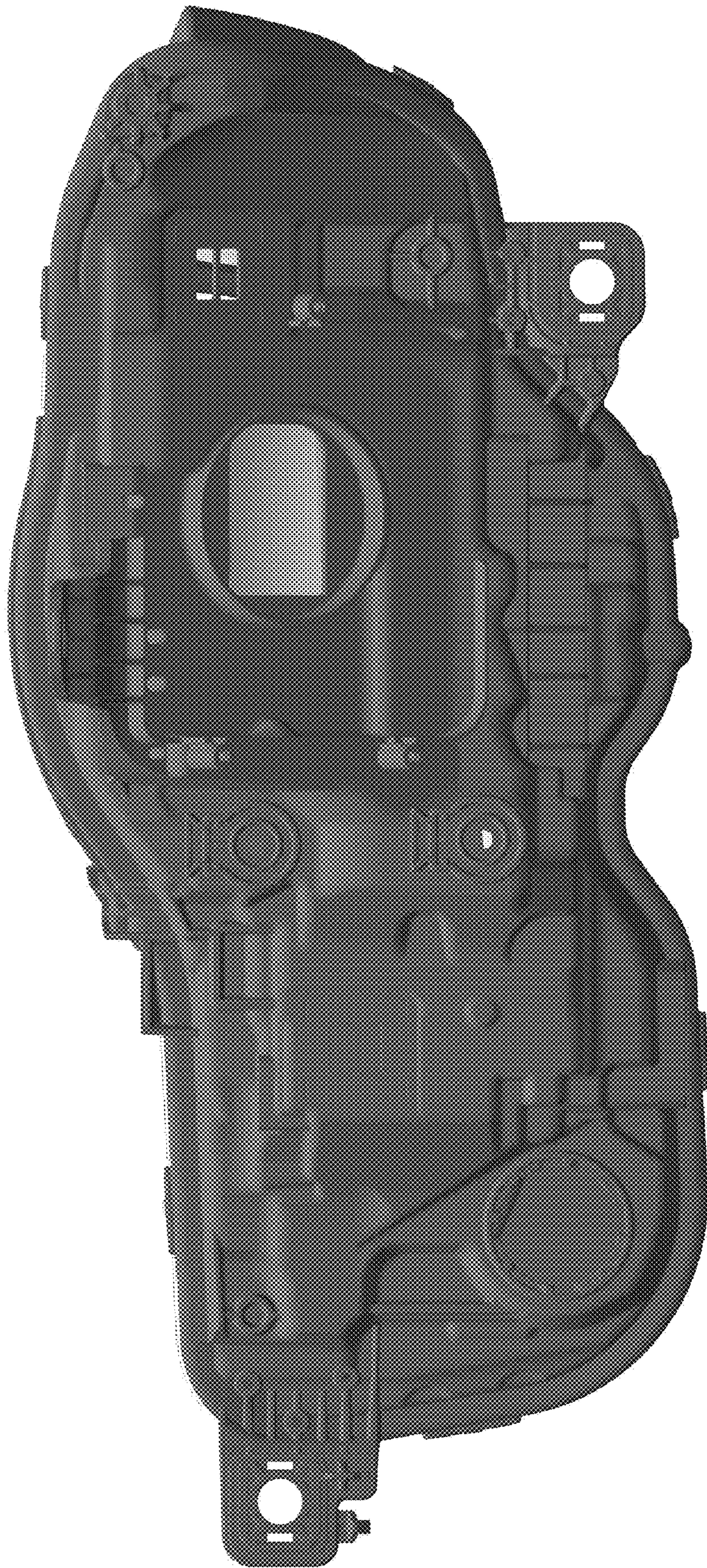

FIG. 6

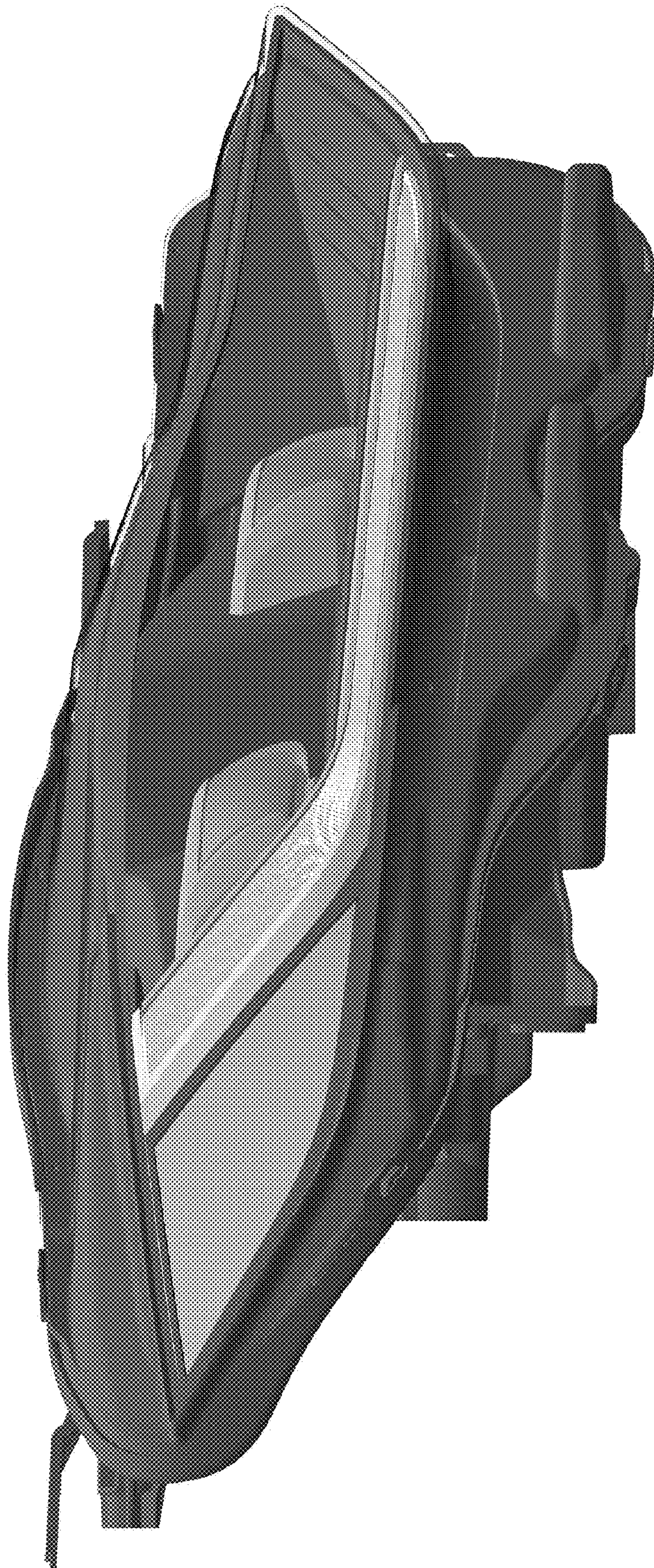

FIG. 7



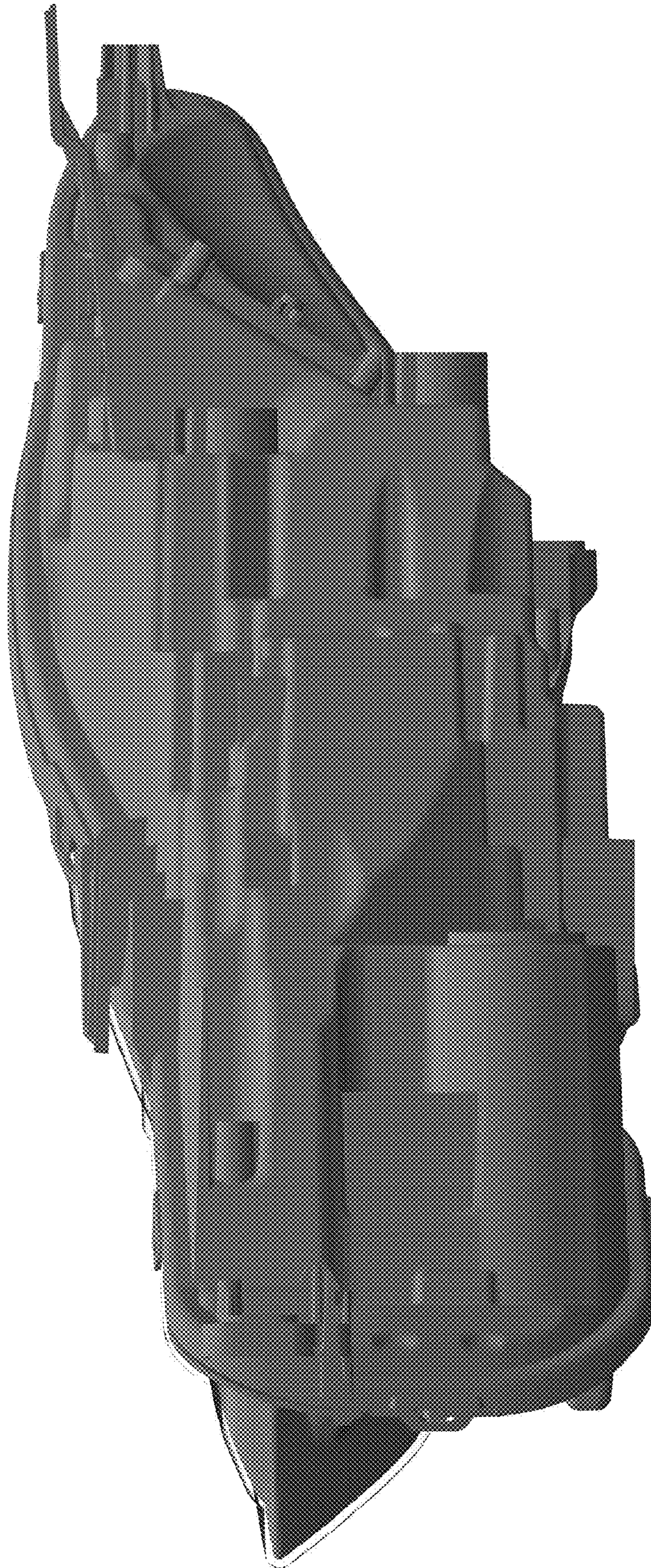

FIG. 8

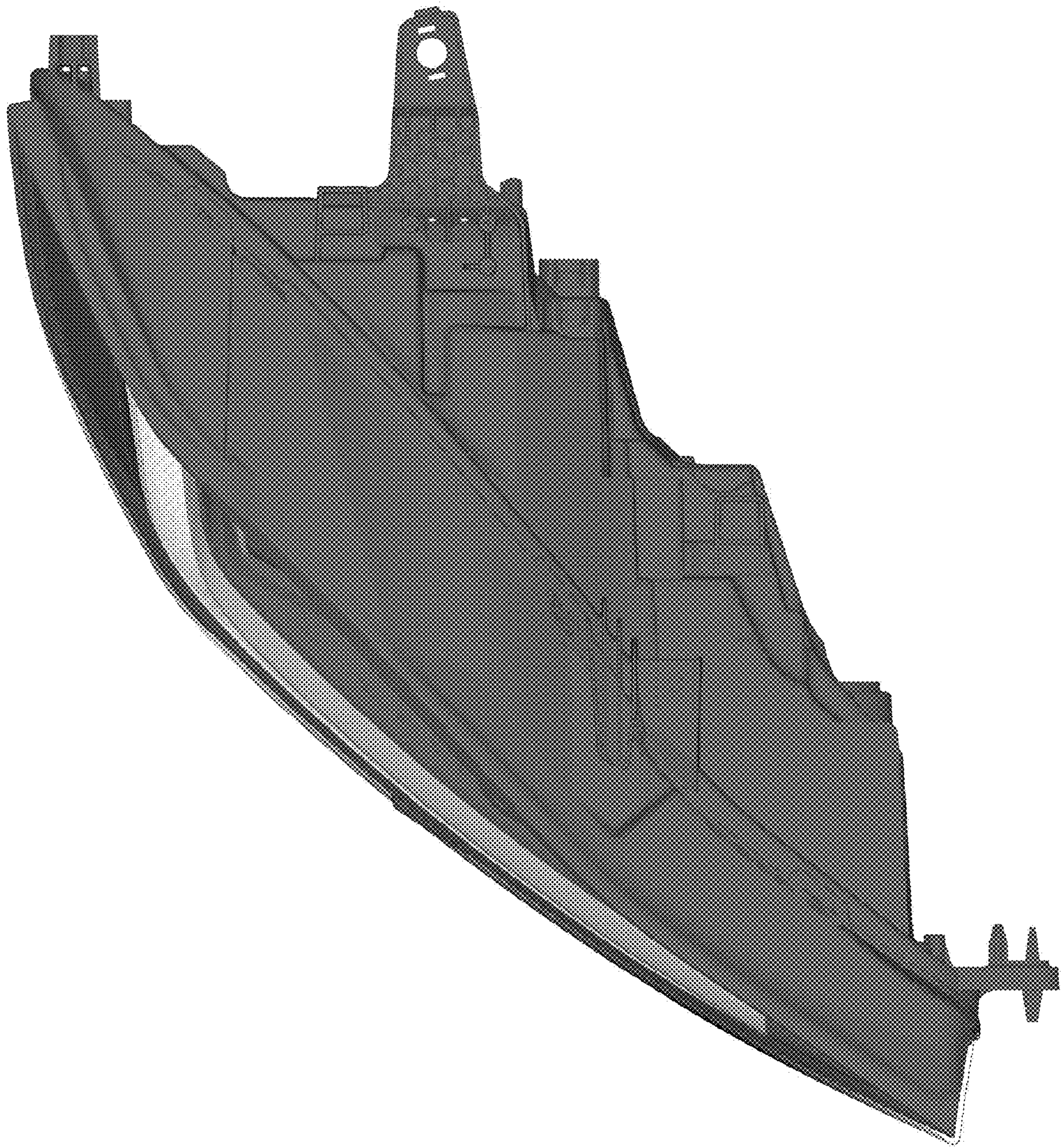

FIG. 9

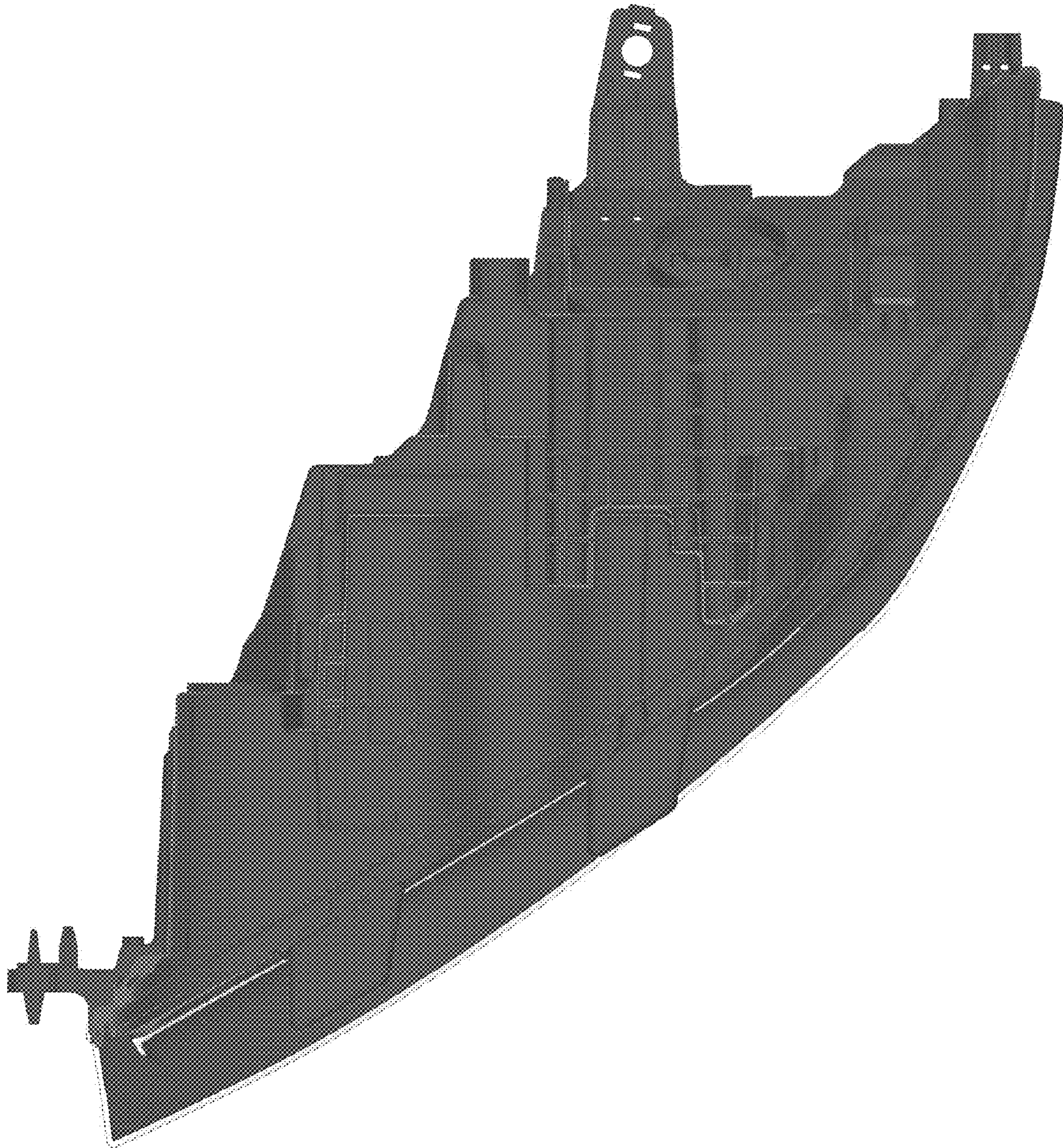

FIG. 10



FIG. 11