



US00D897466S

(12) **United States Design Patent** (10) **Patent No.:** **US D897,466 S**  
**Bang** (45) **Date of Patent:** **\*\* Sep. 29, 2020**

(54) **GRIP FOR GOLF CLUB**  
(71) Applicant: **Ki-Woong Bang**, Seongnam-si (KR)  
(72) Inventor: **Ki-Woong Bang**, Seongnam-si (KR)  
(\*\*) Term: **15 Years**  
(21) Appl. No.: **29/671,209**  
(22) Filed: **Nov. 26, 2018**

(30) **Foreign Application Priority Data**  
Oct. 5, 2018 (KR) ..... 30-2018-0045839  
(51) **LOC (12) Cl.** ..... **21-02**  
(52) **U.S. Cl.**  
USPC ..... **D21/756**  
(58) **Field of Classification Search**  
USPC ..... D21/756-758  
CPC ..... A63B 60/06-60/34; A63B 60/00; A63B  
60/46; A63B 59/20; A63B 59/40; A63B  
59/60-59/80; A63B 49/00-49/14; A63B  
53/00-53/14  
See application file for complete search history.

(56) **References Cited**  
U.S. PATENT DOCUMENTS  
621,993 A \* 3/1899 Crosier ..... A63B 53/14  
473/298  
1,305,952 A \* 6/1919 Suesman ..... A63B 53/14  
473/295  
2,131,966 A \* 10/1938 Nelson ..... A63B 53/14  
473/203  
3,173,689 A \* 3/1965 Serblin ..... A63B 53/12  
473/203  
4,067,573 A \* 1/1978 Key, Jr. .... A63B 53/14  
473/201  
D258,168 S \* 2/1981 MacDougall ..... D21/756

D265,576 S \* 7/1982 Lamkin ..... D21/756  
4,736,950 A \* 4/1988 Doyle ..... A63B 49/08  
473/538  
6,902,492 B1 \* 6/2005 Strand ..... A63B 53/14  
473/201  
D525,332 S \* 7/2006 Miller ..... D21/756  
D525,333 S \* 7/2006 Miller ..... D21/756  
D525,672 S \* 7/2006 Miller ..... D21/756  
D525,673 S \* 7/2006 Miller ..... D21/756  
D544,934 S \* 6/2007 De Gruccio ..... D21/721  
D605,241 S \* 12/2009 Ferris ..... D21/756  
D658,247 S \* 4/2012 Button ..... D21/756

\* cited by examiner

*Primary Examiner* — Mitchell I. Siegel  
(74) *Attorney, Agent, or Firm* — Mark M. Friedman

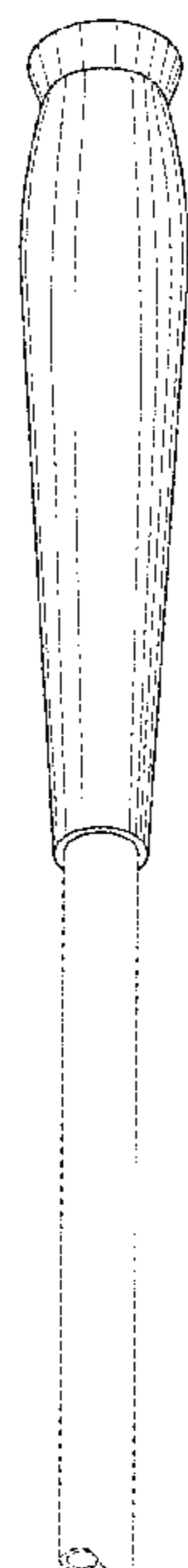
(57) **CLAIM**

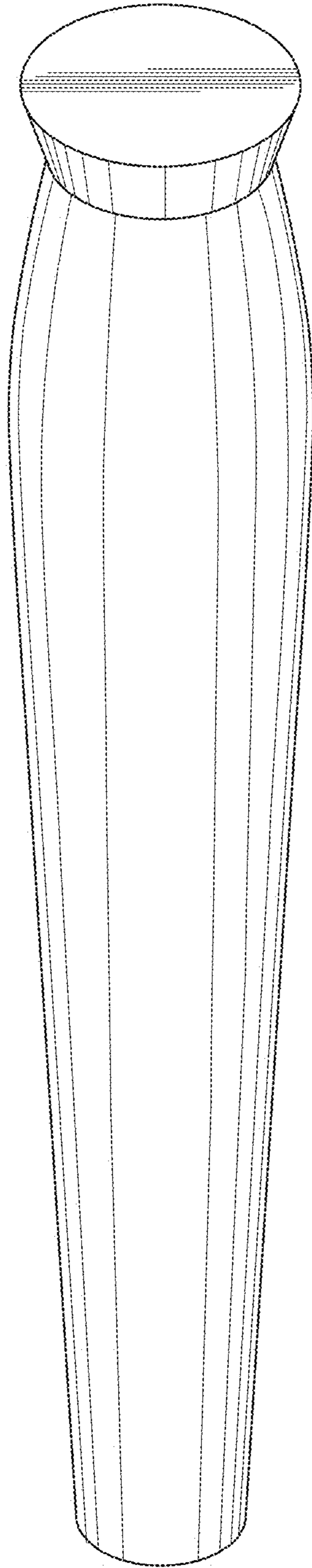
The ornamental design for a grip for golf club, as shown and described.

**DESCRIPTION**

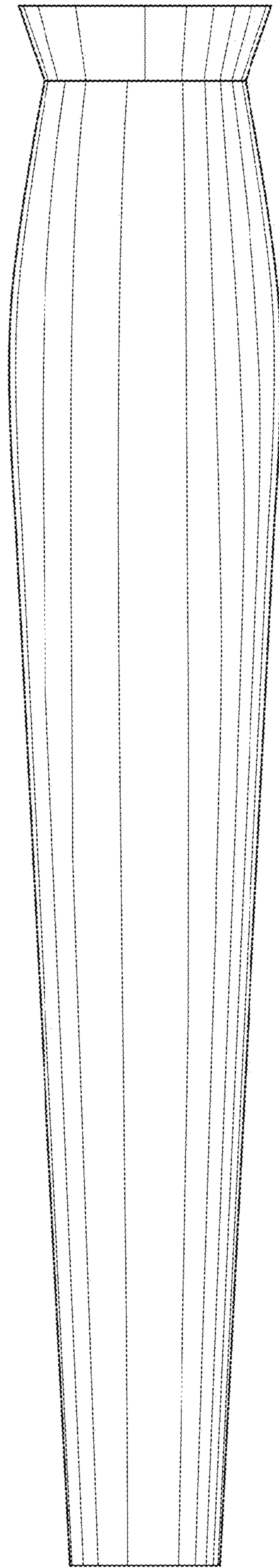
FIG. 1 is a front perspective view of a grip for golf club showing my design;  
FIG. 2 is a front view thereof;  
FIG. 3 is a rear view thereof;  
FIG. 4 is a left side view thereof;  
FIG. 5 is a right side view thereof;  
FIG. 6 is a top view thereof;  
FIG. 7 is a bottom view thereof;  
FIG. 8 is a cross-sectional view taken along line VIII-VIII' of FIG. 6; and,  
FIG. 9 is a bottom perspective view of FIG. 1. The fragmented unclaimed shaft forms no part of the claimed design. The broken line showing of the fragmented shaft is included for the purpose of illustrating unclaimed subject matter and forms no part of the claimed design.

**1 Claim, 8 Drawing Sheets**

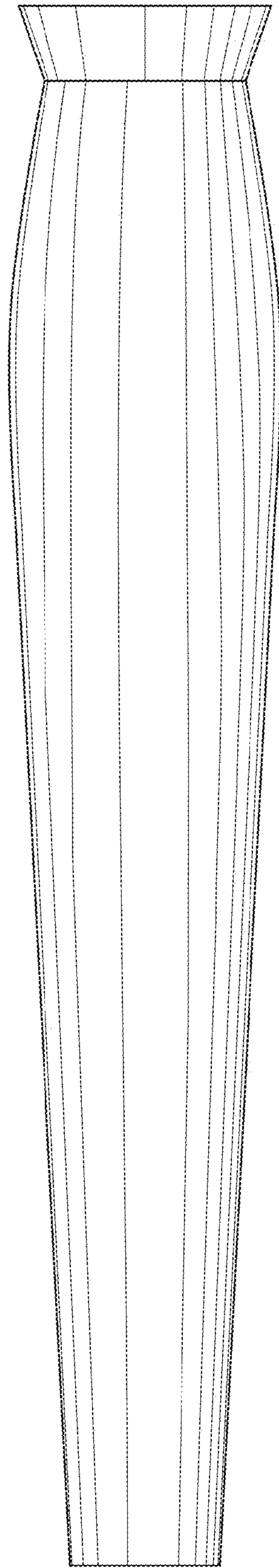




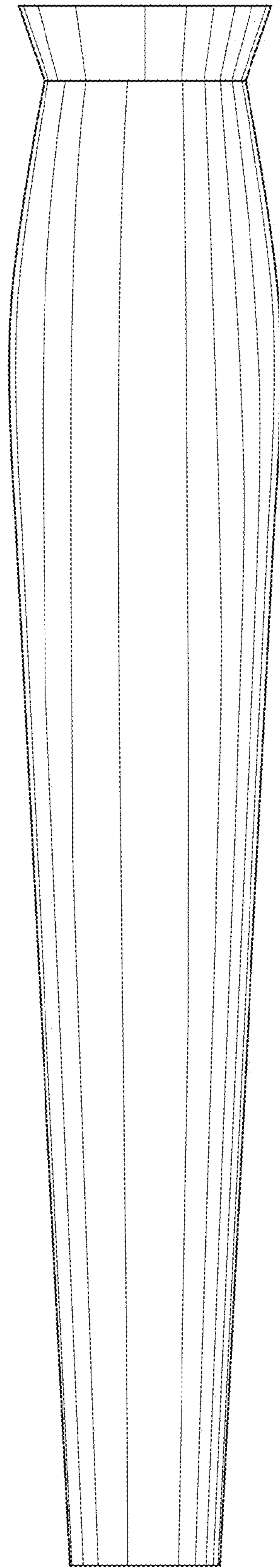
*FIG. 1*



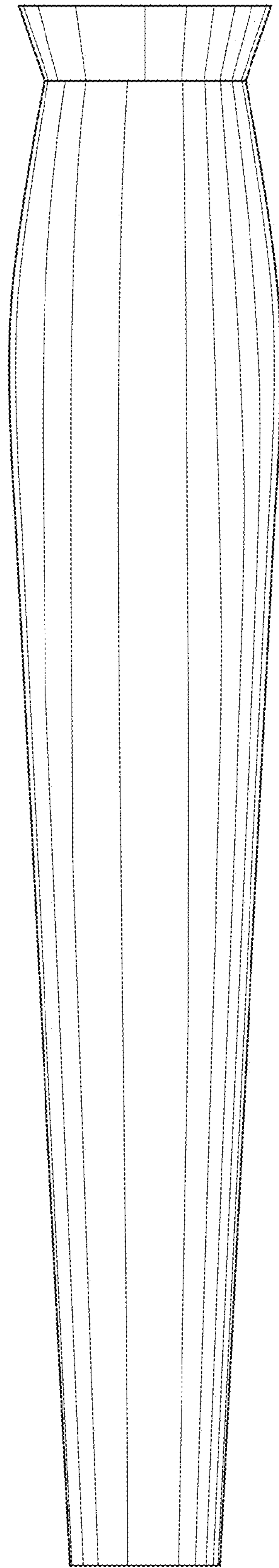
*FIG. 2*



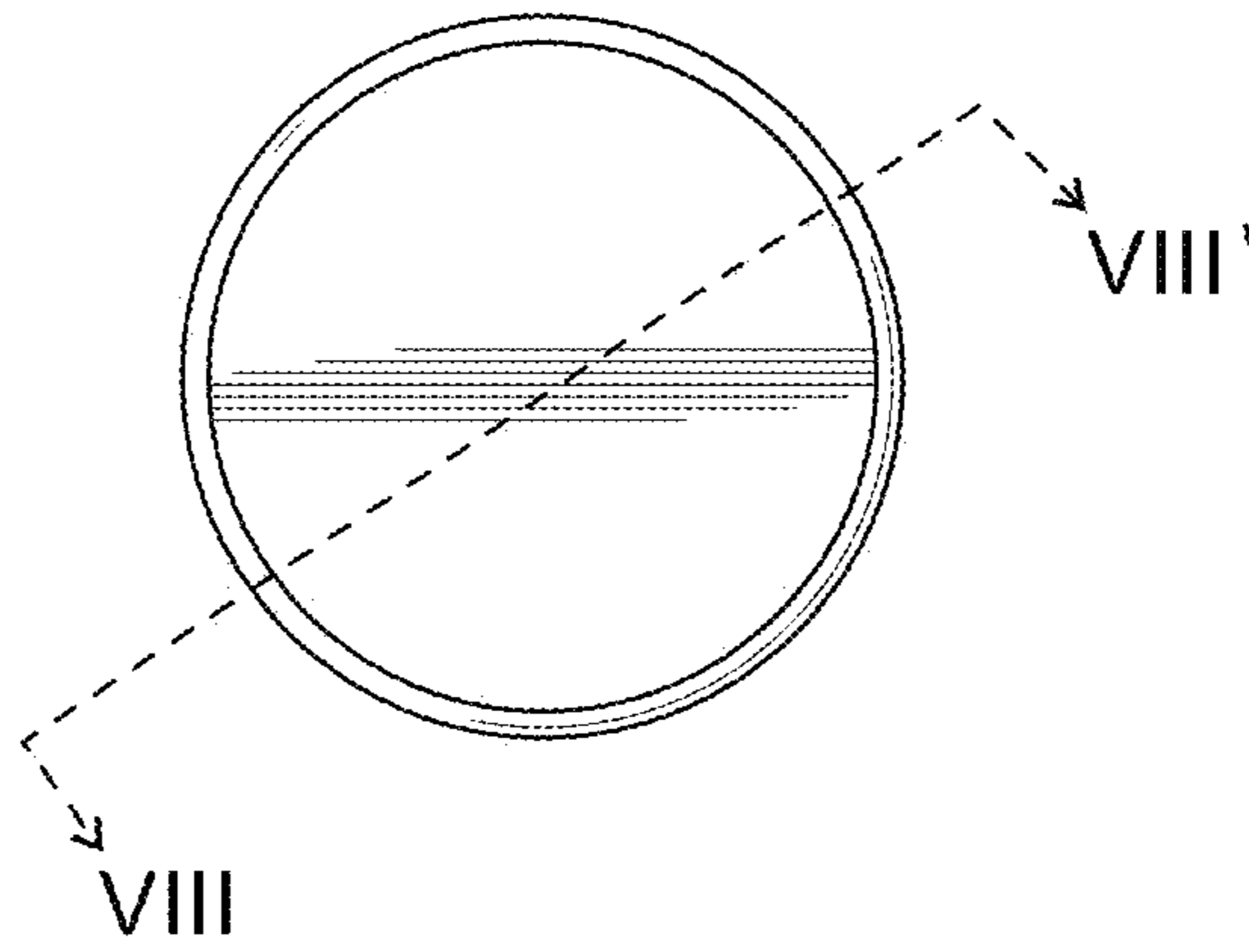
*FIG. 3*



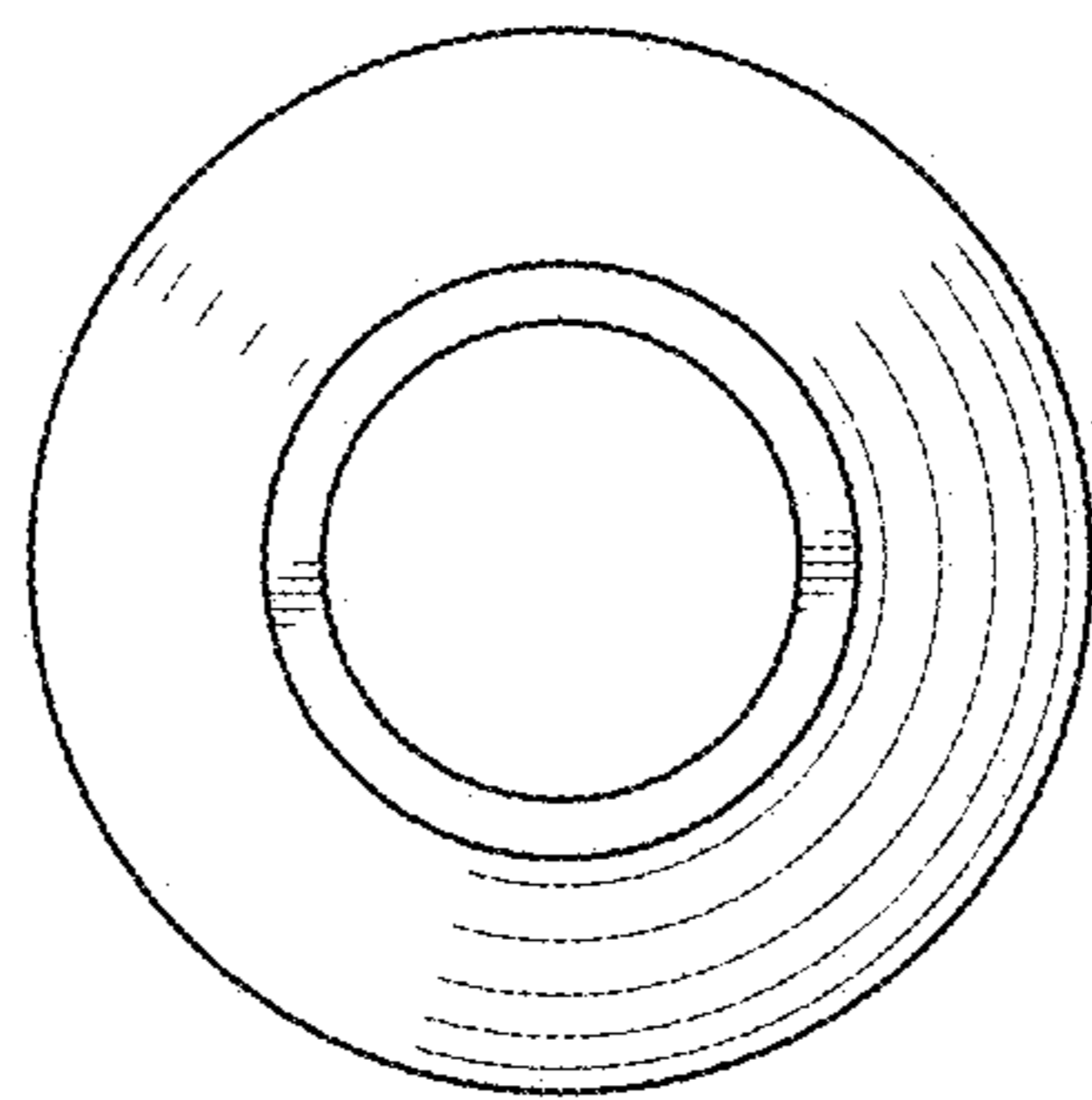
*FIG. 4*



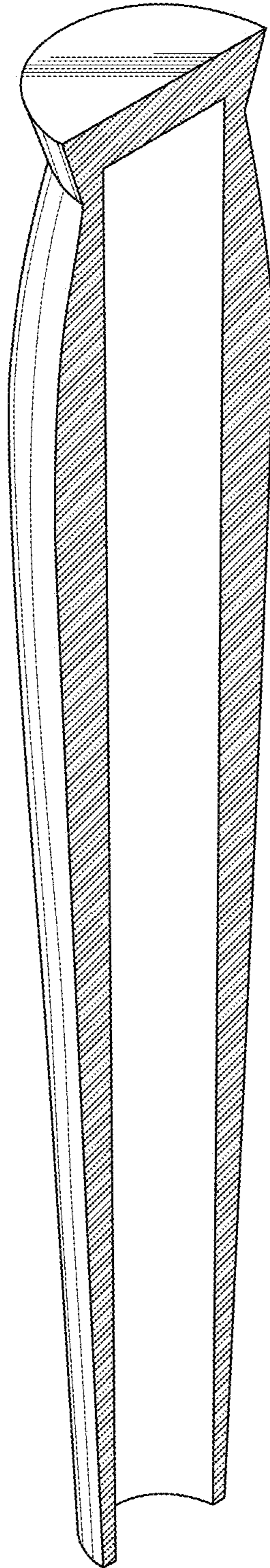
*FIG. 5*



*FIG. 6*



*FIG. 7*



*FIG. 8*



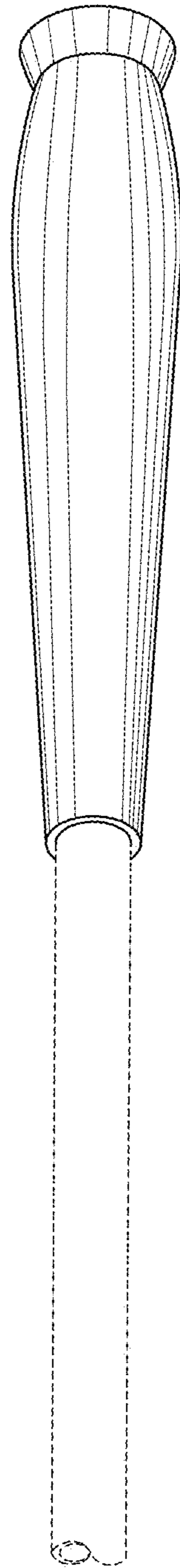


FIG. 9