



US00D897452S

(12) **United States Design Patent**
Lin

(10) **Patent No.:** **US D897,452 S**

(45) **Date of Patent:** **** Sep. 29, 2020**

(54) **HIGH SPEED MONSTER TRUCK CAR**

(71) Applicant: **Zhonghua Lin**, Guangdong (CN)

(72) Inventor: **Zhonghua Lin**, Guangdong (CN)

(**) Term: **15 Years**

(21) Appl. No.: **29/704,099**

(22) Filed: **Sep. 1, 2019**

(51) **LOC (12) Cl.** **12-15**

(52) **U.S. Cl.**
USPC **D21/550; D21/552**

(58) **Field of Classification Search**
USPC D12/1, 3, 12, 14, 15, 16, 82, 85, 86, 87,
D12/88; D21/433, 434, 533, 548, 550,
D21/551, 552, 557, 559, 763; 180/65.1,
180/89.1; 296/181.1

CPC B60K 17/00; B60R 2021/132; B60Y
2200/124; B60Y 2200/20; B60Y 2200/24;
B60Y 2200/25; B60Y 2200/42; B60Y
2200/40; B60Y 2200/126; F41H 7/00

See application file for complete search history.

(56) **References Cited**

U.S. PATENT DOCUMENTS

D327,237	S *	6/1992	Miyamoto	D12/87
D425,141	S *	5/2000	Park	D21/550
D640,171	S *	6/2011	Danisi	D12/87
9,352,636	B1 *	5/2016	Johnson	B60J 1/025
9,566,858	B2 *	2/2017	Hicke	B60K 11/04
9,765,553	B2 *	9/2017	Suzuki	B60J 5/0487
9,815,346	B2 *	11/2017	Suzuki	B60G 7/001
10,369,886	B2 *	8/2019	Safranski	B60G 3/202
D871,512	S *	12/2019	Cai	D21/550
2018/0236833	A1 *	8/2018	Despres-Nadeau	B60G 7/005
2019/0145465	A1 *	5/2019	Olason	B60K 17/35
					180/344
2020/0130450	A1 *	4/2020	Nakashima	B60G 1/04
2020/0198554	A1 *	6/2020	Nakamura	B60R 13/07

OTHER PUBLICATIONS

4wd Brushless Motor Dune Buggy, www.alibaba.com [online].
Published on or before Jul. 13, 2020, [retrieved on Jul. 13, 2020].
Retrieved from the Internet: <URL:https://www.alibaba.com/product-
detail/HSP-94202PRO-HSP-2-4ghz-RC_60309289537.html> (Year:
2020).*

* cited by examiner

Primary Examiner — Karen E Kearney

Assistant Examiner — Adam C Mager

(57) **CLAIM**

The ornamental design for a high speed monster truck car,
as shown and described.

DESCRIPTION

FIG. 1 is a front elevational view of a high speed monster
truck car showing my new design;
FIG. 2 is a rear elevational view thereof;
FIG. 3 is a left side view thereof;
FIG. 4 is a right side view thereof;
FIG. 5 is a top plan view thereof;
FIG. 6 is a bottom plan view thereof;
FIG. 7 is a top, front and right side perspective view thereof;
FIG. 8 is a top, front and left side perspective view thereof;
FIG. 9 is a top, rear and right side perspective view thereof;
FIG. 10 is a top, rear and left side perspective view thereof;
FIG. 11 is a bottom, front and left side perspective view
thereof;
FIG. 12 is a bottom, front and right side perspective view
thereof;
FIG. 13 is a bottom, rear and left side perspective view
thereof; and,
FIG. 14 is a bottom, rear and right side perspective view
thereof.

1 Claim, 14 Drawing Sheets

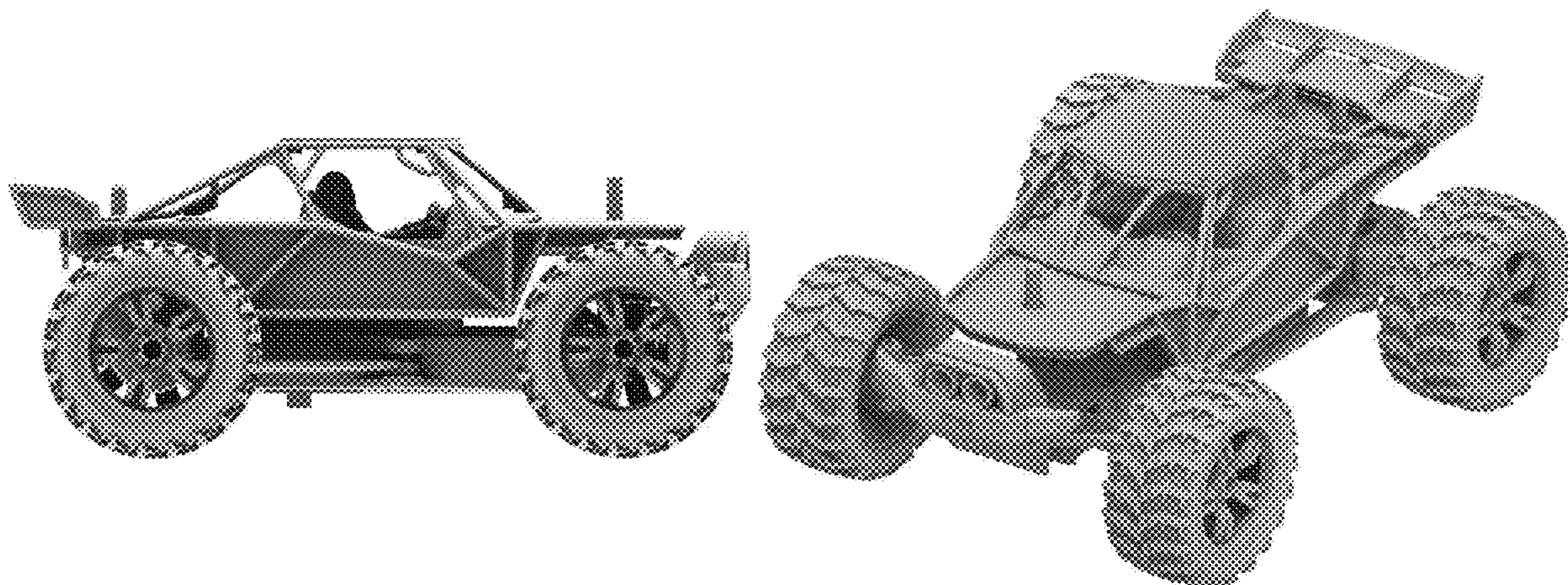

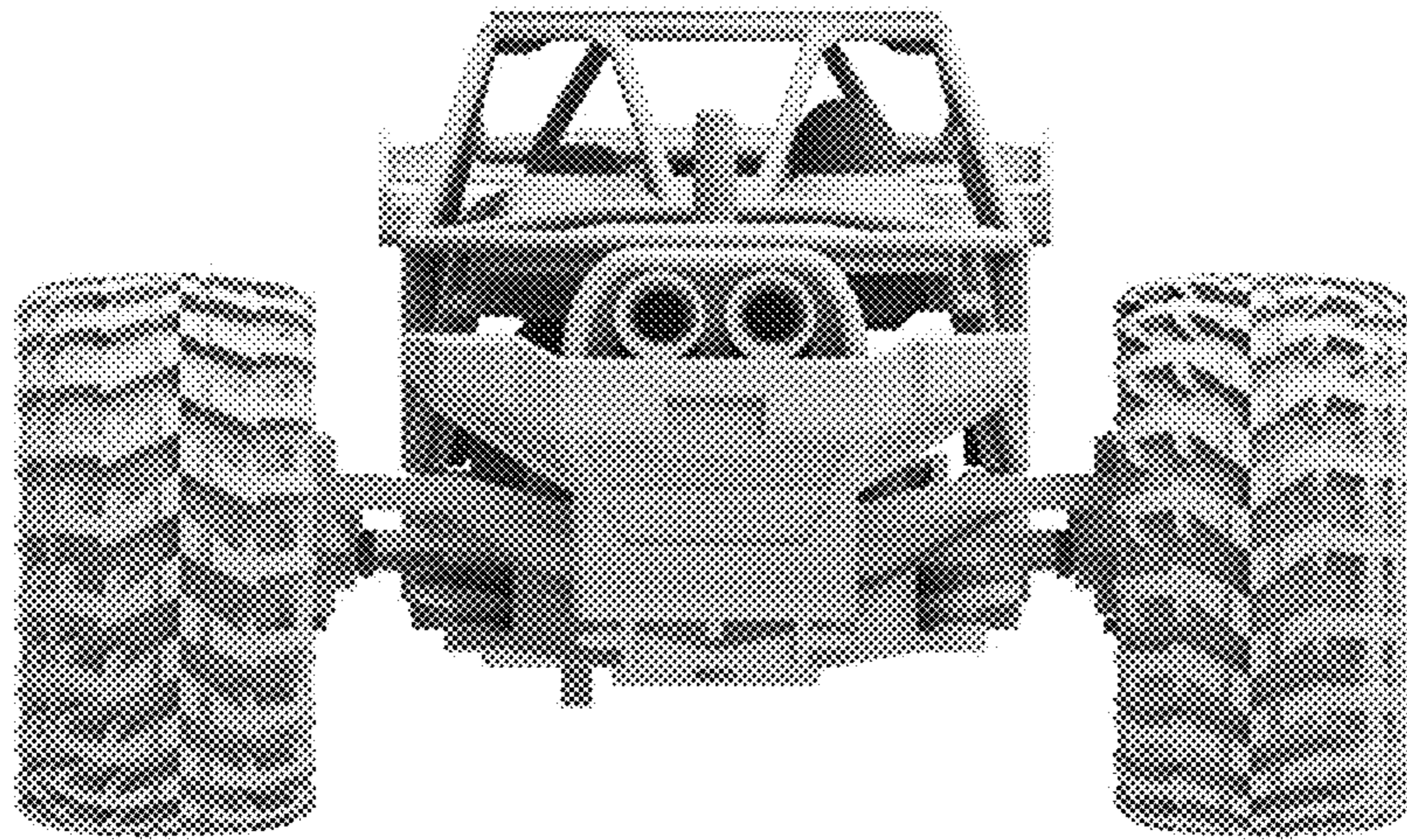

FIG. 1

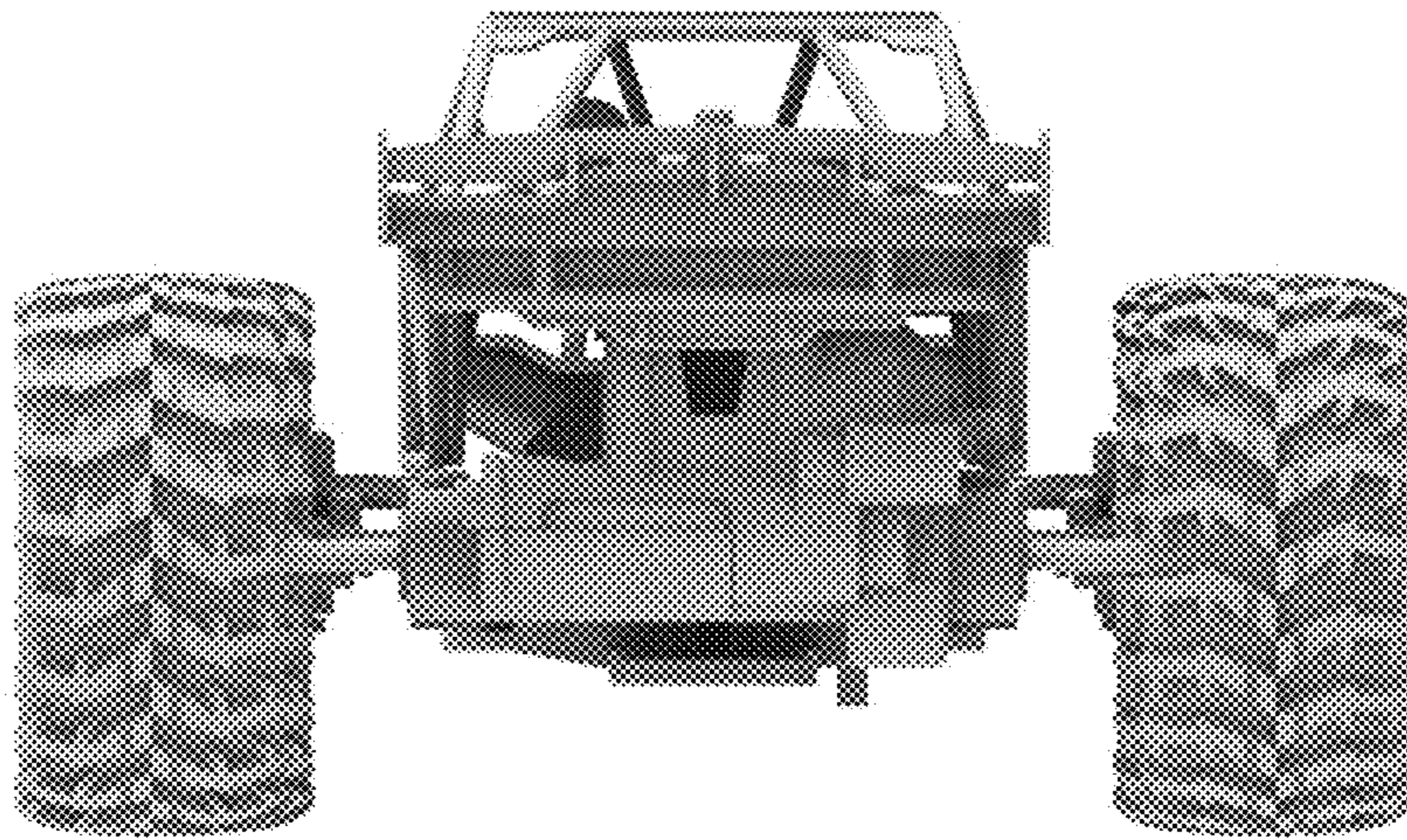

FIG. 2

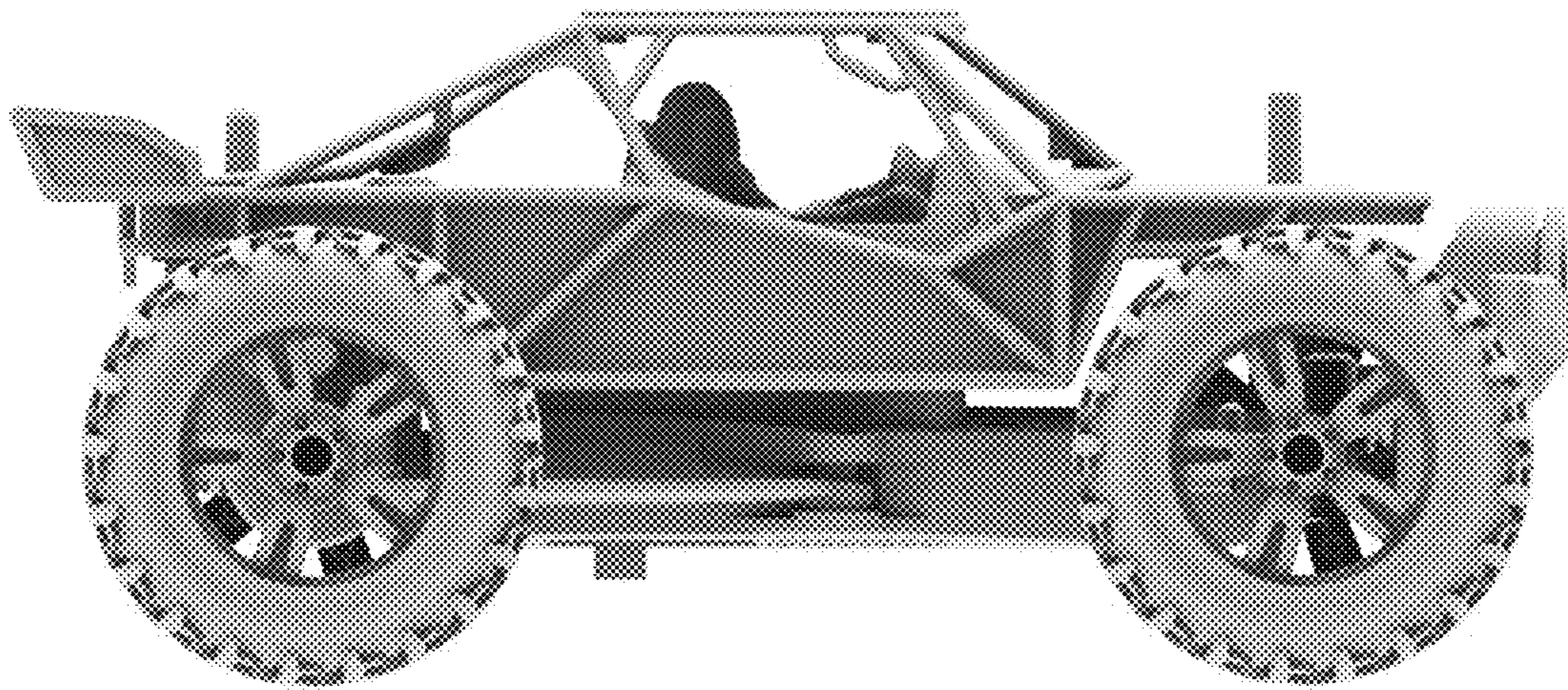

FIG. 3

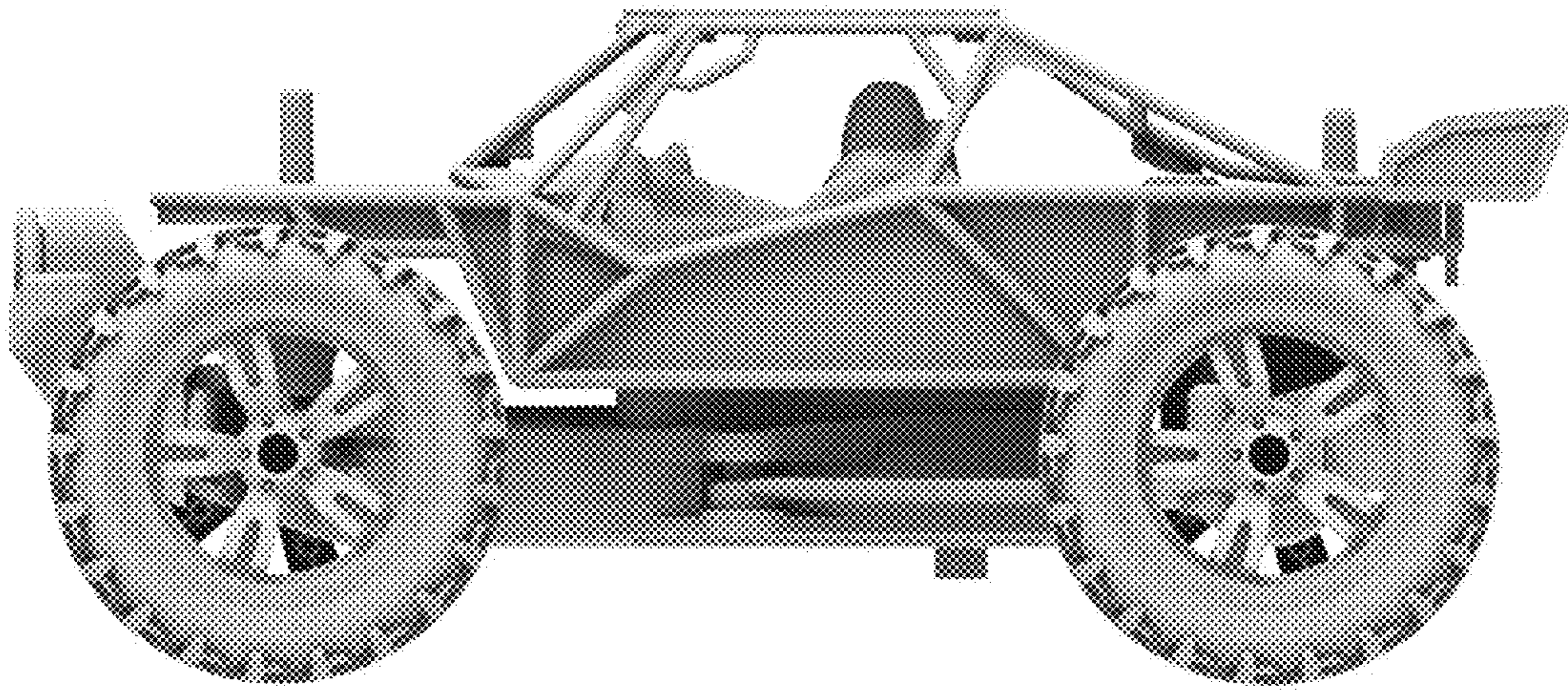

FIG. 4

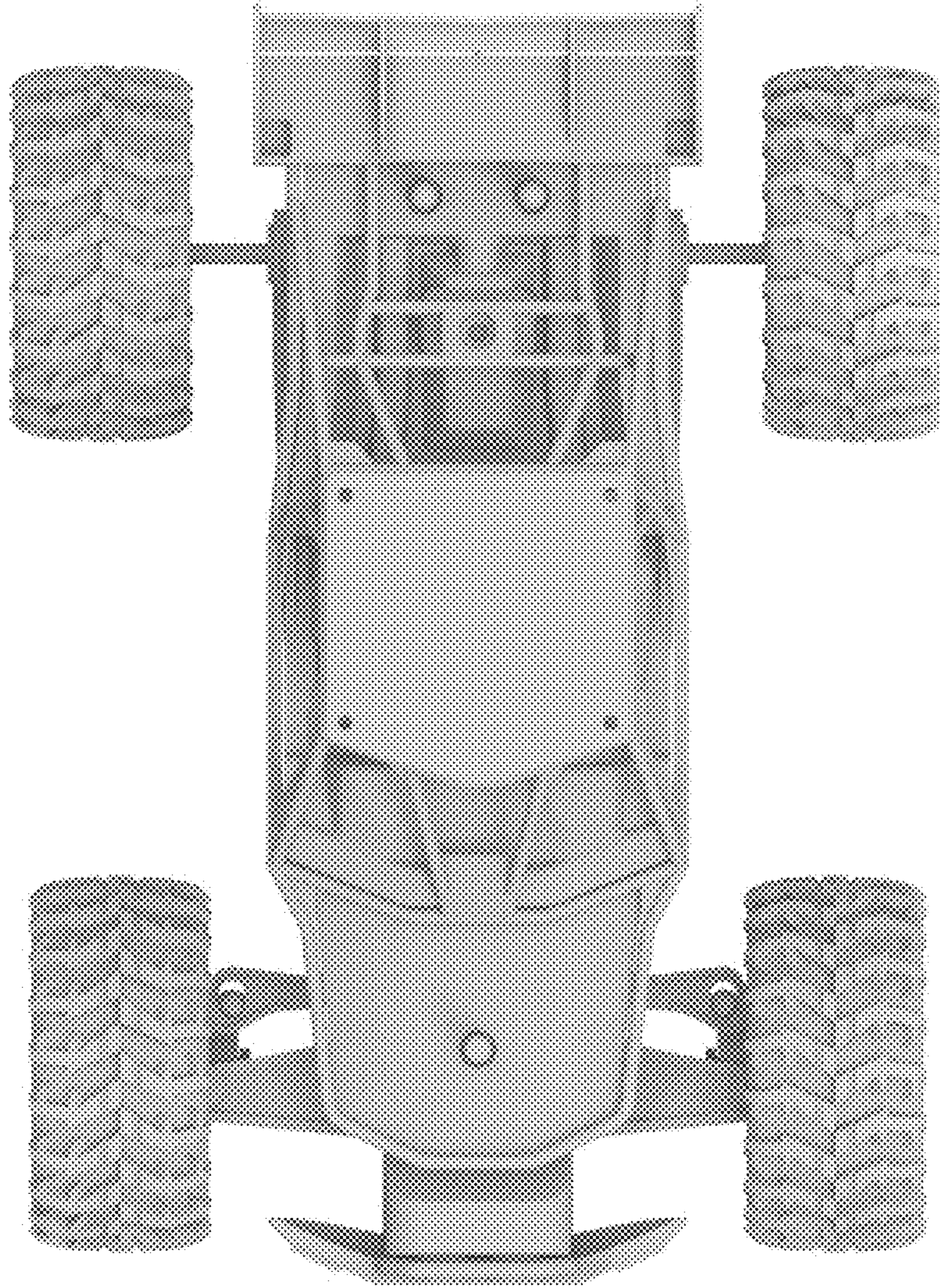

FIG. 5

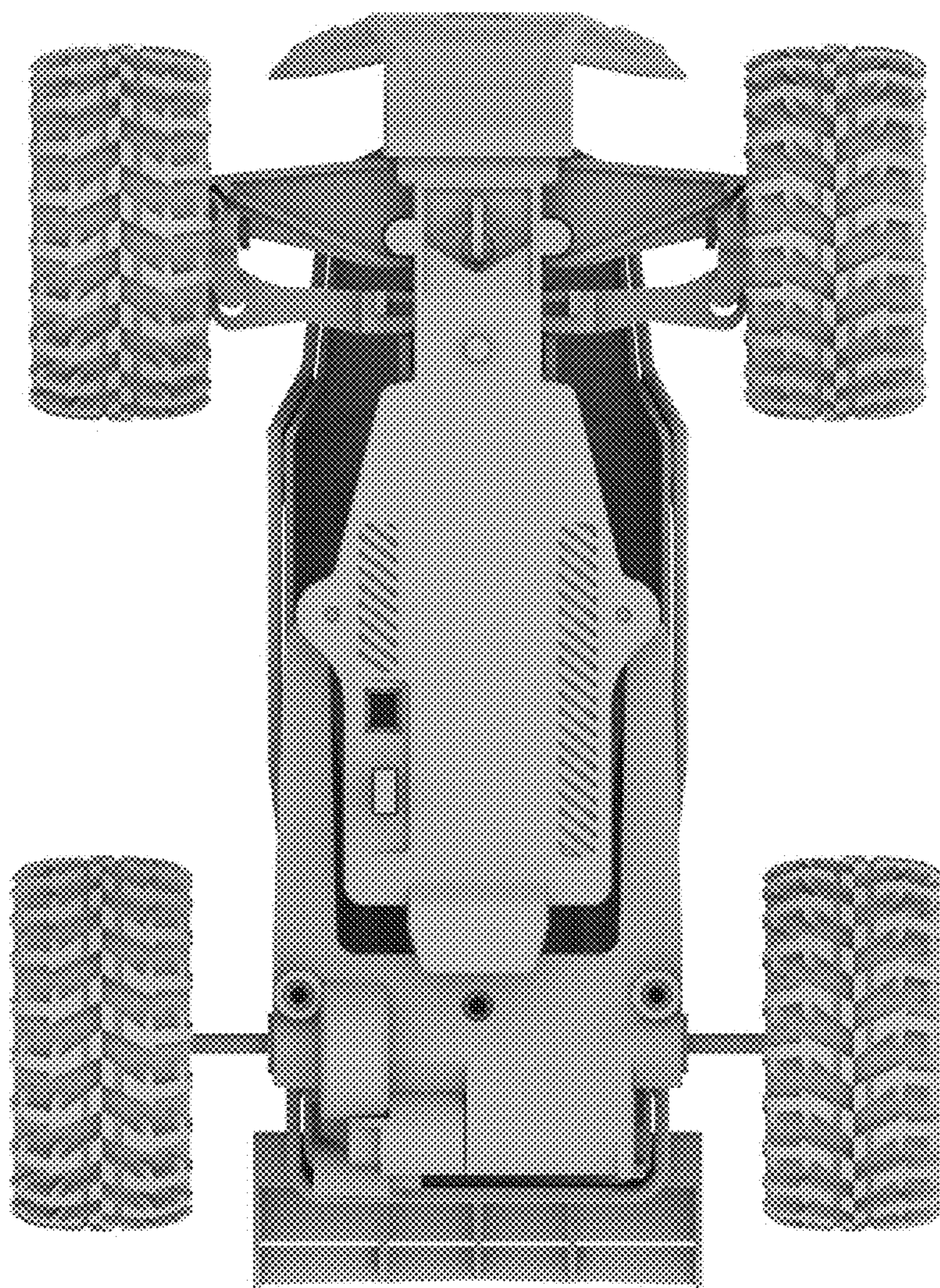

FIG. 6



FIG. 7



FIG. 8

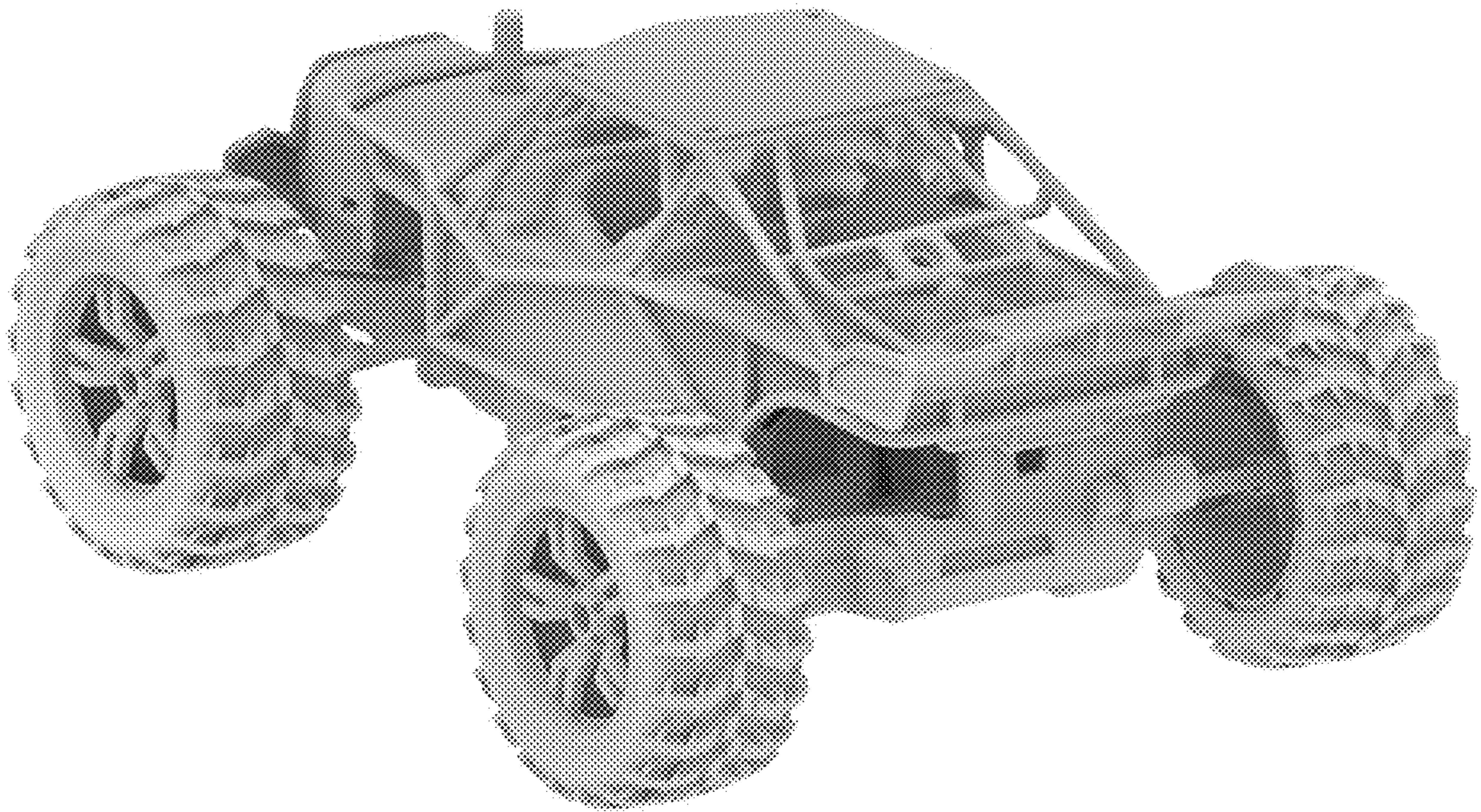

FIG. 9

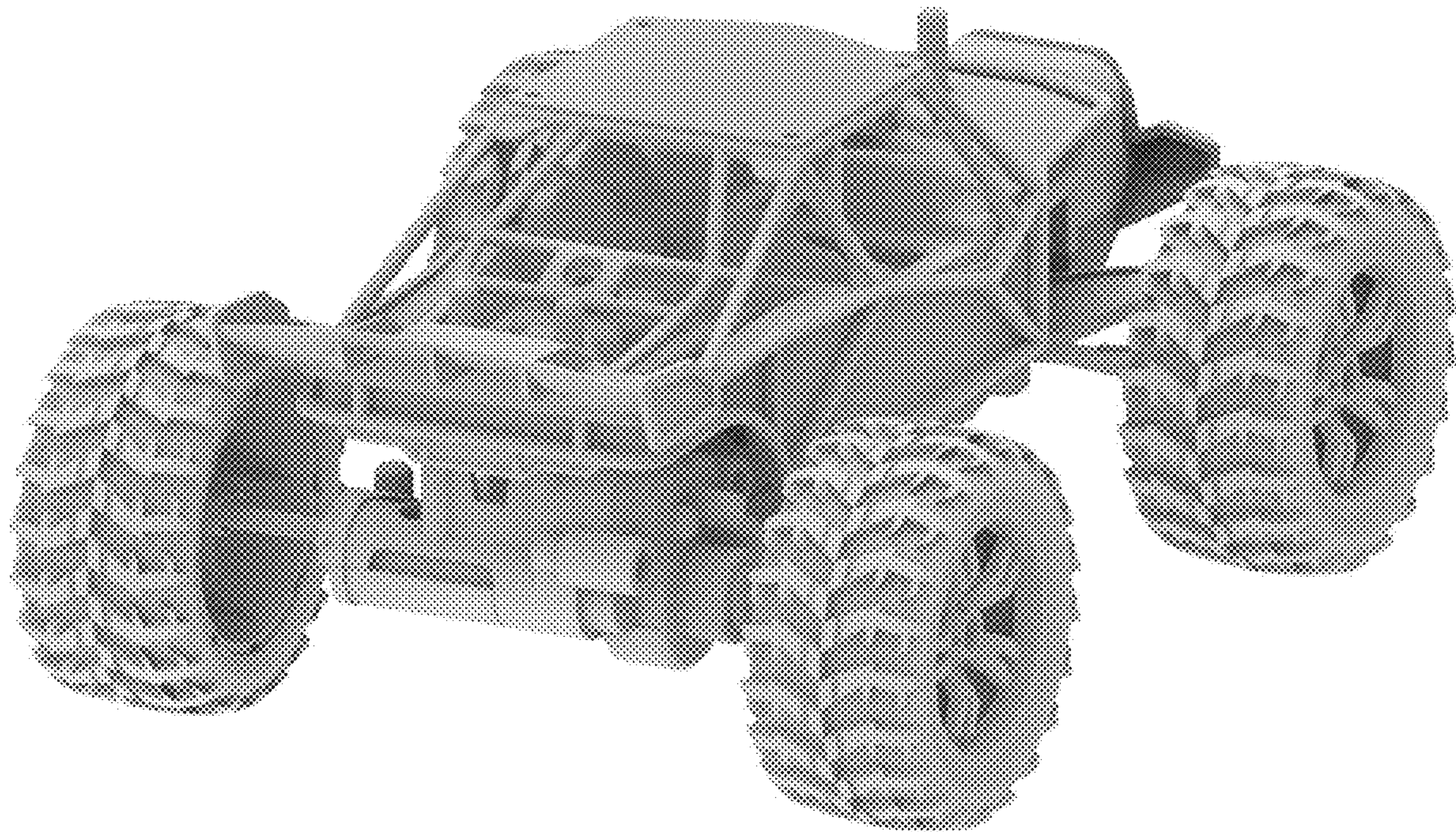

FIG. 10

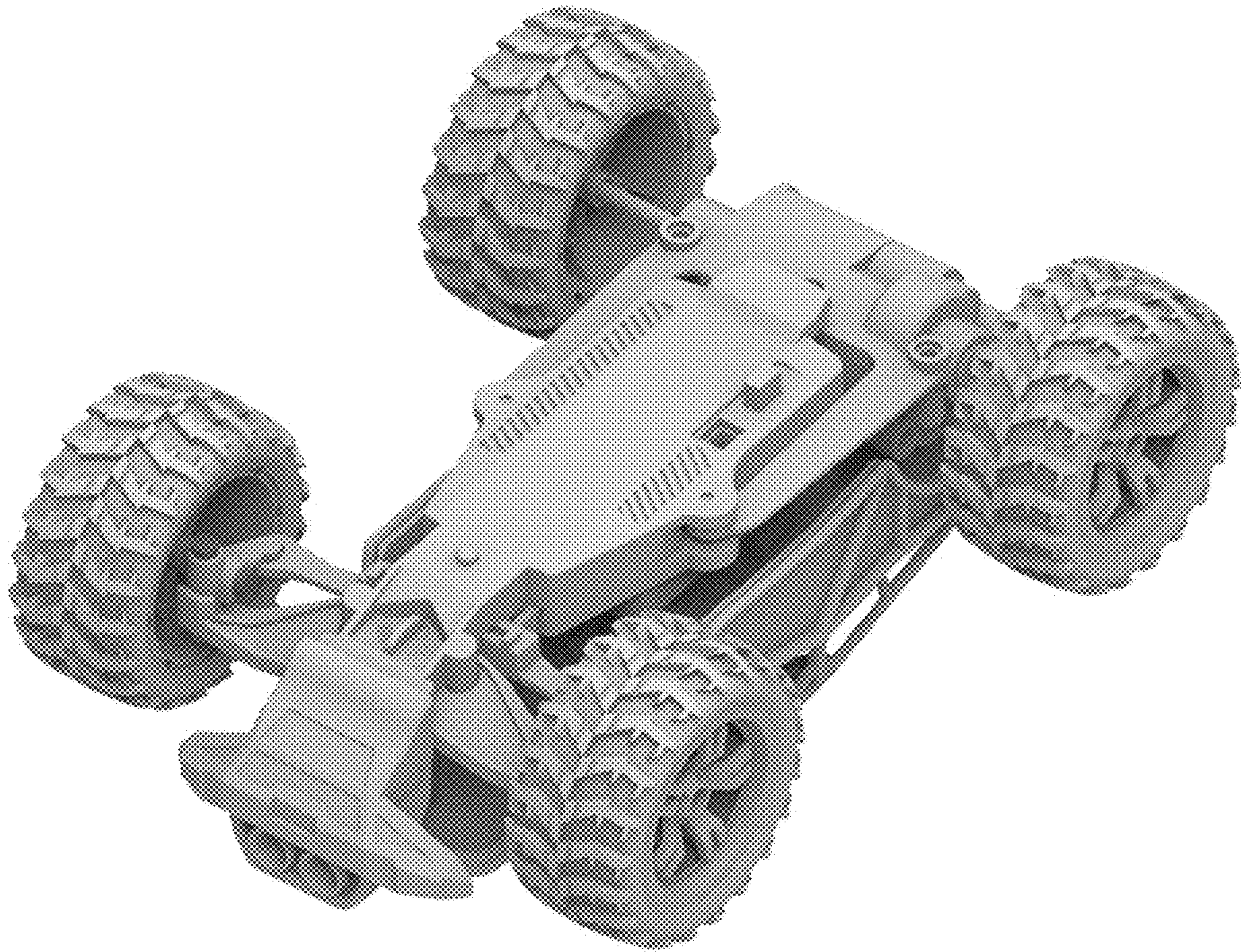

FIG. 11

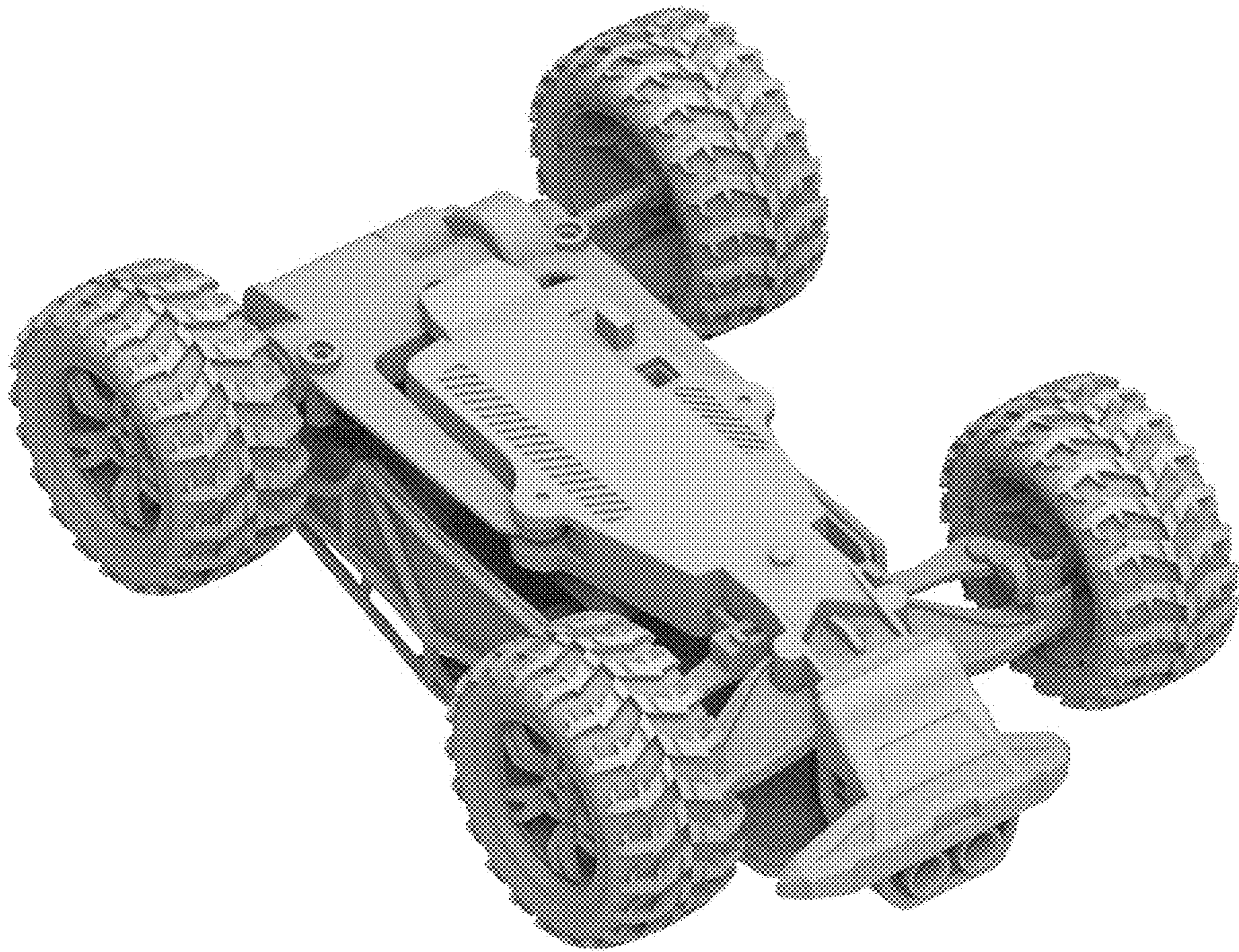

FIG. 12

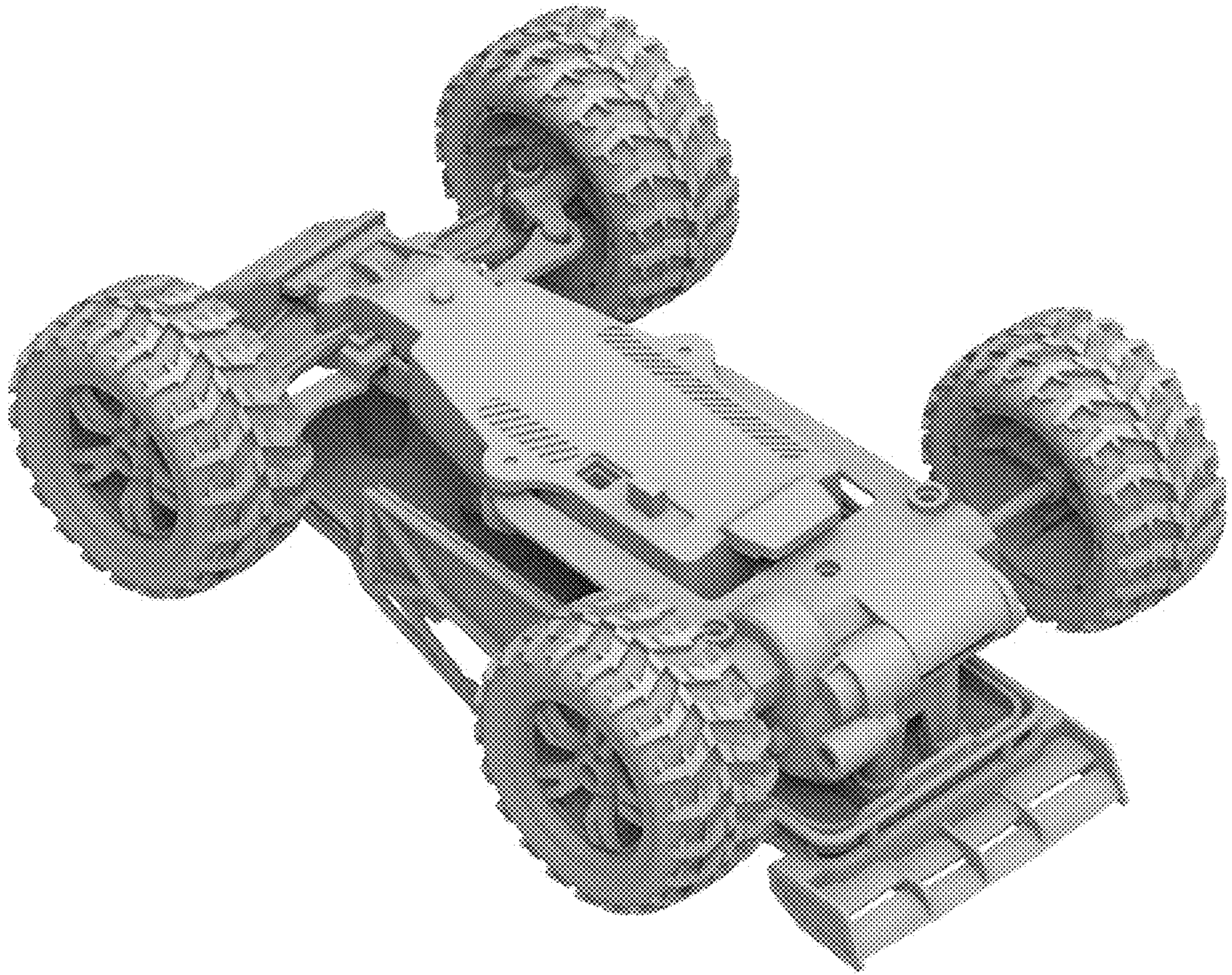

FIG. 13

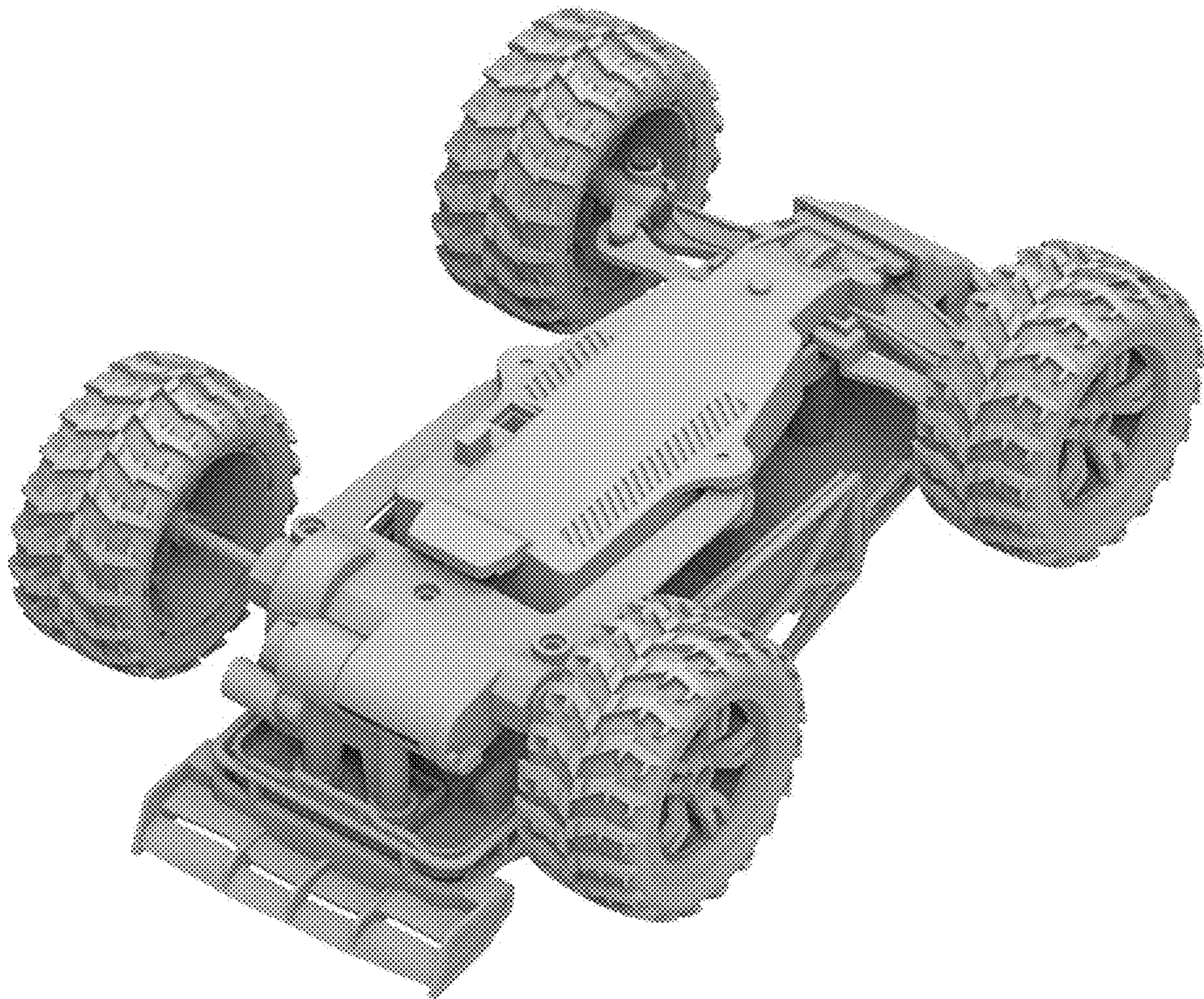

FIG. 14