



US00D897429S

(12) **United States Design Patent**
Chan et al.

(10) **Patent No.:** **US D897,429 S**

(45) **Date of Patent:** **** Sep. 29, 2020**

(54) **ELECTRIC PUNCH**

(71) Applicant: **Eagle (Guangzhou) Technology Development Limited**, Guangzhou (CN)

(72) Inventors: **Siu Leung Chan**, Guangzhou (CN); **Huixiong Xiong**, Guangzhou (CN); **Jiwu Liang**, Guangzhou (CN); **Lan Tu**, Guangzhou (CN)

(73) Assignee: **Eagle (Guangzhou) Technology Development Limited**, Guangzhou (CN)

(**) Term: **15 Years**

(21) Appl. No.: **29/669,419**

(22) Filed: **Nov. 8, 2018**

(51) **LOC (12) Cl.** **19-02**

(52) **U.S. Cl.**
USPC **D19/72**

(58) **Field of Classification Search**
USPC D19/65, 72, 73, 74, 99, 100; D8/49, 50, D8/98
CPC B26F 1/04; B26F 1/36; B26F 1/00
See application file for complete search history.

(56) **References Cited**

U.S. PATENT DOCUMENTS

1,995,887	A *	3/1935	Kimball	B23Q 1/4804	30/289
3,906,633	A *	9/1975	Inoue	B26F 1/36	30/358
D256,479	S *	8/1980	Manusch	D19/72	
D263,276	S *	3/1982	Takagi	D8/102	
4,726,505	A *	2/1988	Okazaki	B25C 5/15	227/120
4,742,744	A *	5/1988	Lindberg	B26D 7/00	83/167
D300,332	S *	3/1989	Mori	D19/72	

D306,551	S *	3/1990	Yuen	D19/73	
D318,999	S *	8/1991	Tanigami	D8/102	
D320,812	S *	10/1991	Yuen	D19/100	
D354,987	S *	1/1995	Yuen	D19/73	
5,487,634	A *	1/1996	Vercillo	B26F 1/04	412/16
D372,737	S *	8/1996	Herbst	D19/65	
D373,793	S *	9/1996	Herbst	D19/65	
D401,131	S *	11/1998	Miyamoto	D8/98	
5,967,786	A *	10/1999	Wang	B26D 5/10	434/81
D467,778	S *	12/2002	Nolan	D19/72	
D512,461	S *	12/2005	Tsuruha	D19/73	
D541,867	S *	5/2007	Kent	D19/72	
D542,848	S *	5/2007	Kent	D19/72	
8,127,651	B2 *	3/2012	Henkemeyer	B26F 1/36	83/549
D662,138	S *	6/2012	Chuang	D19/72	
D662,139	S *	6/2012	Chuang	D19/72	

(Continued)

Primary Examiner — Elizabeth A. Albert

(74) *Attorney, Agent, or Firm* — Dragon Sun Law Firm, PC; Jinggao Li, Esq.

(57) **CLAIM**

The ornamental design for an electric punch, as shown and described.

DESCRIPTION

FIG. 1 is a perspective view of an electric punch showing our new design;
FIG. 2 is a front view thereof;
FIG. 3 is a back view thereof;
FIG. 4 is a left view thereof;
FIG. 5 is a right view thereof;
FIG. 6 is a top view thereof; and,
FIG. 7 is a bottom view thereof.
The broken lines in the drawings illustrate portions of the electric punch and form no part of the claimed design.

1 Claim, 7 Drawing Sheets

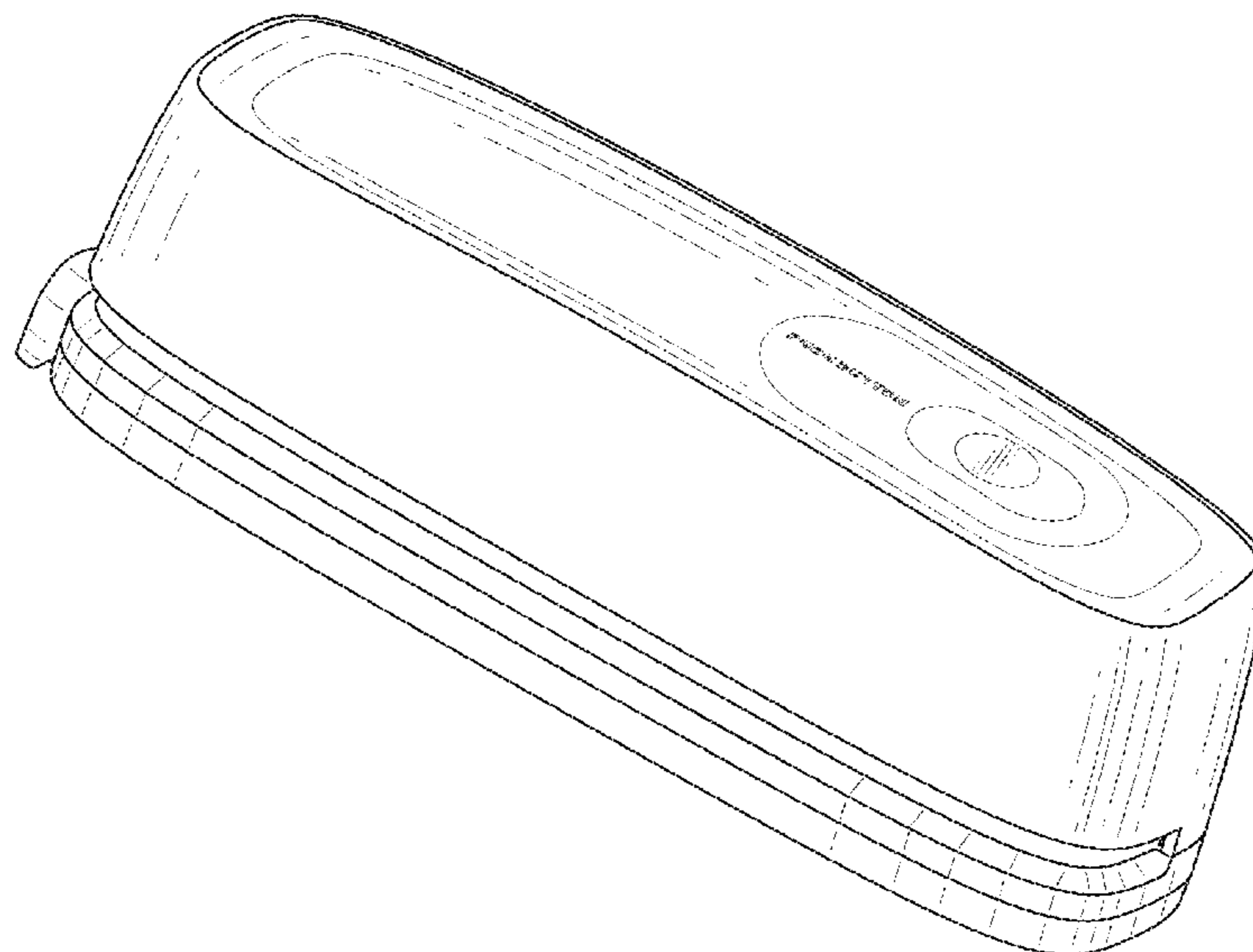

(56)

References Cited

U.S. PATENT DOCUMENTS

D717,868 S * 11/2014 Chuang D19/72
D874,240 S * 2/2020 Souders D8/98

* cited by examiner

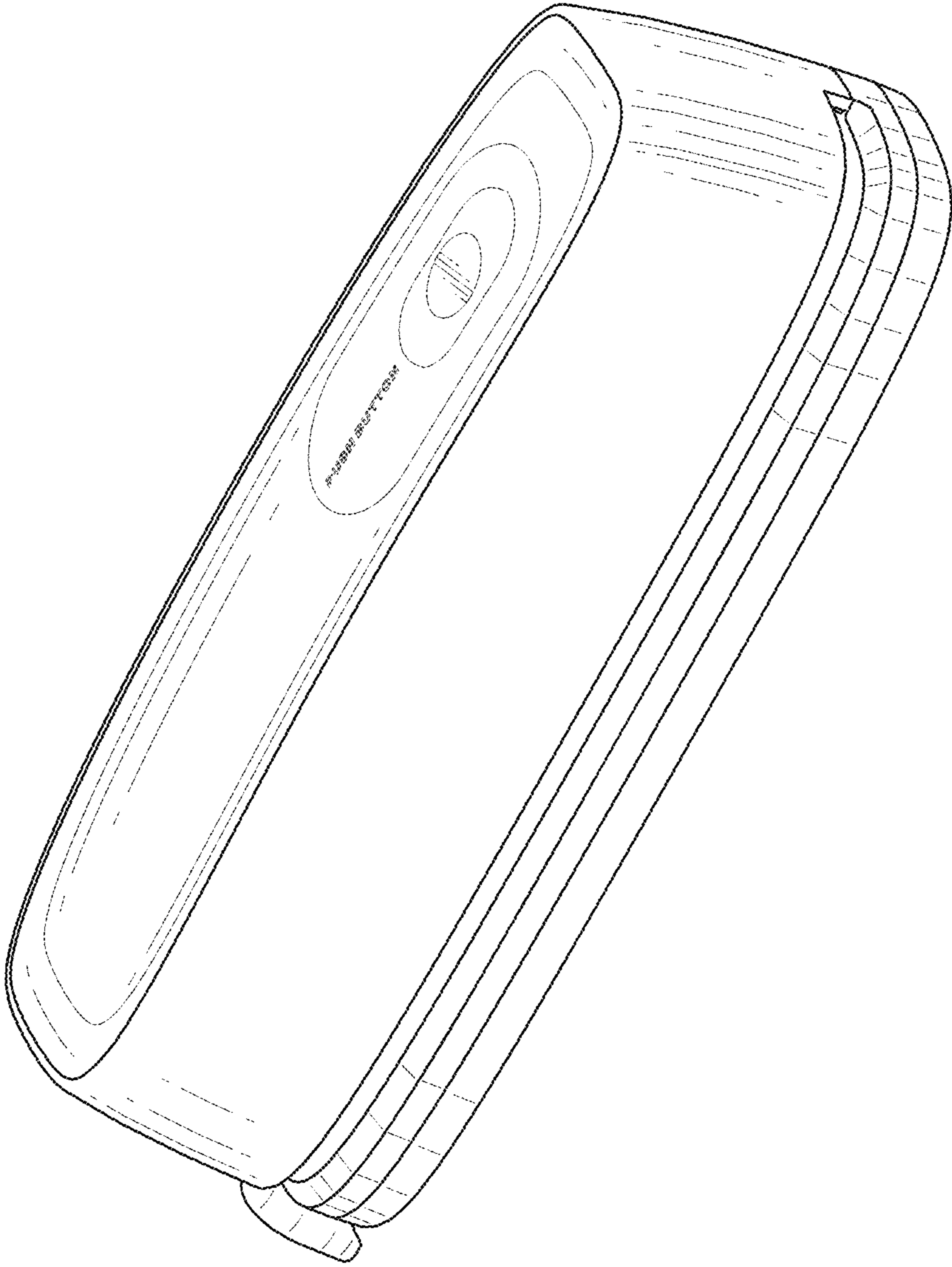

FIG. 1

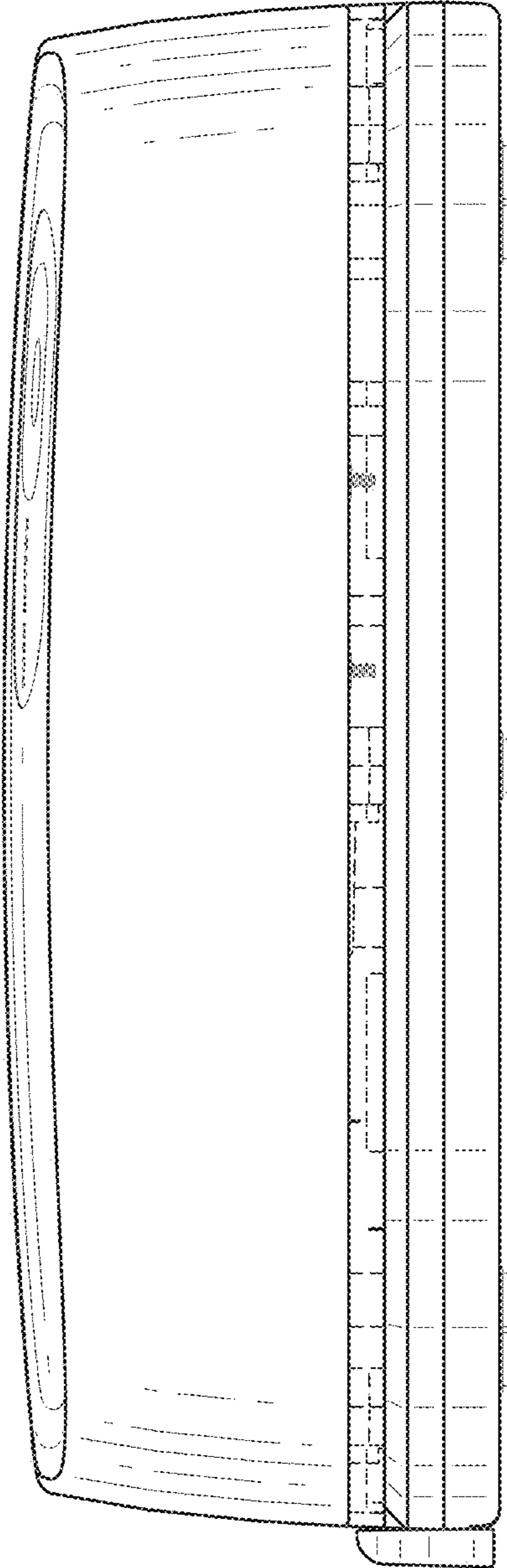

FIG. 2

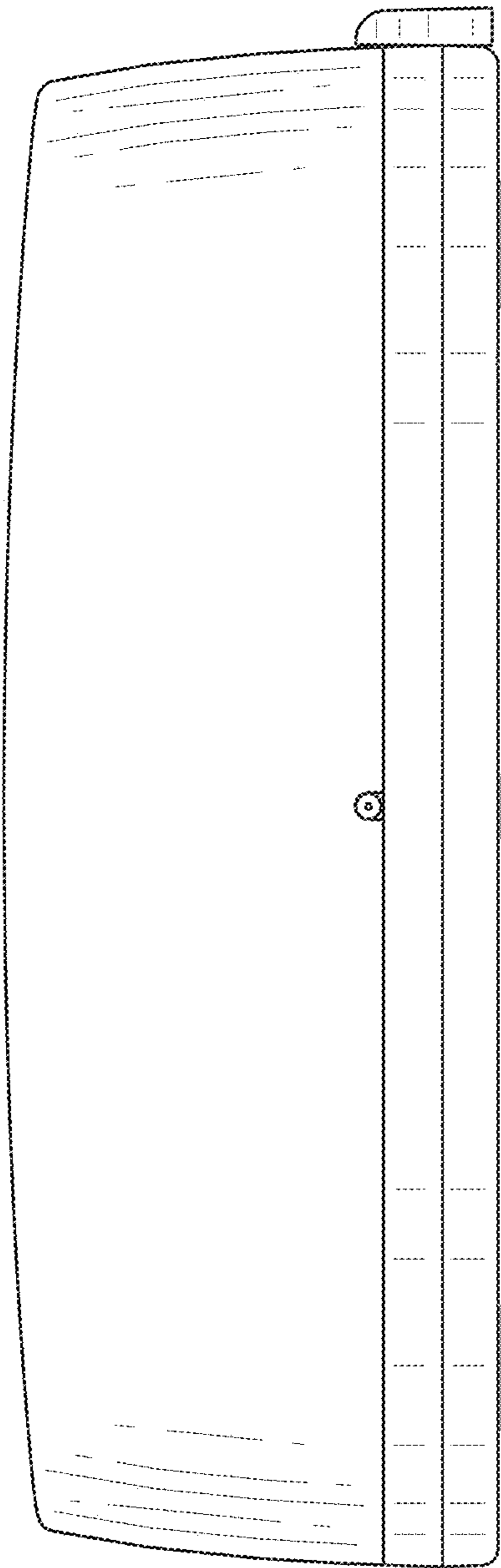

FIG. 3

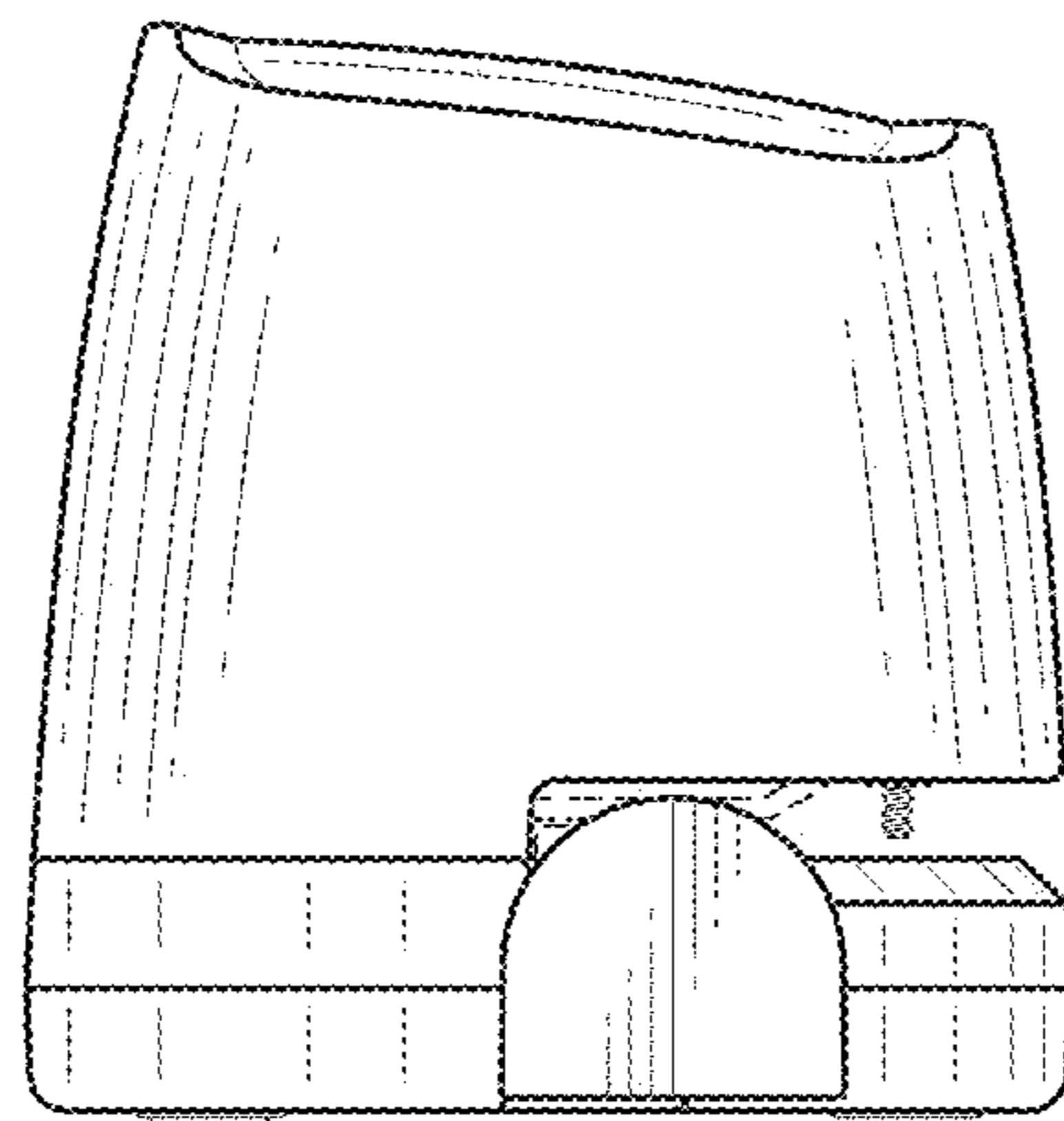

FIG. 4

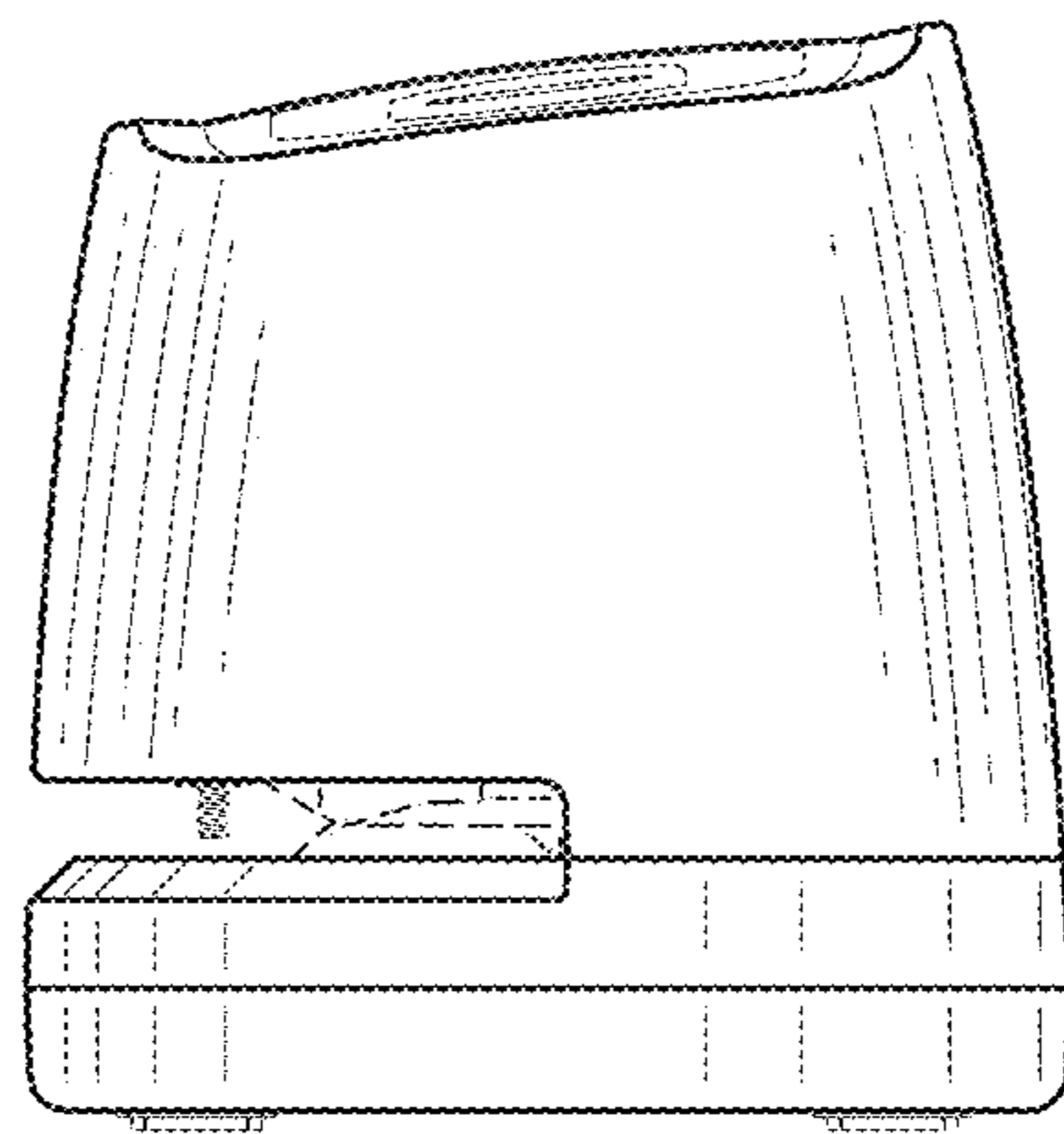

FIG. 5

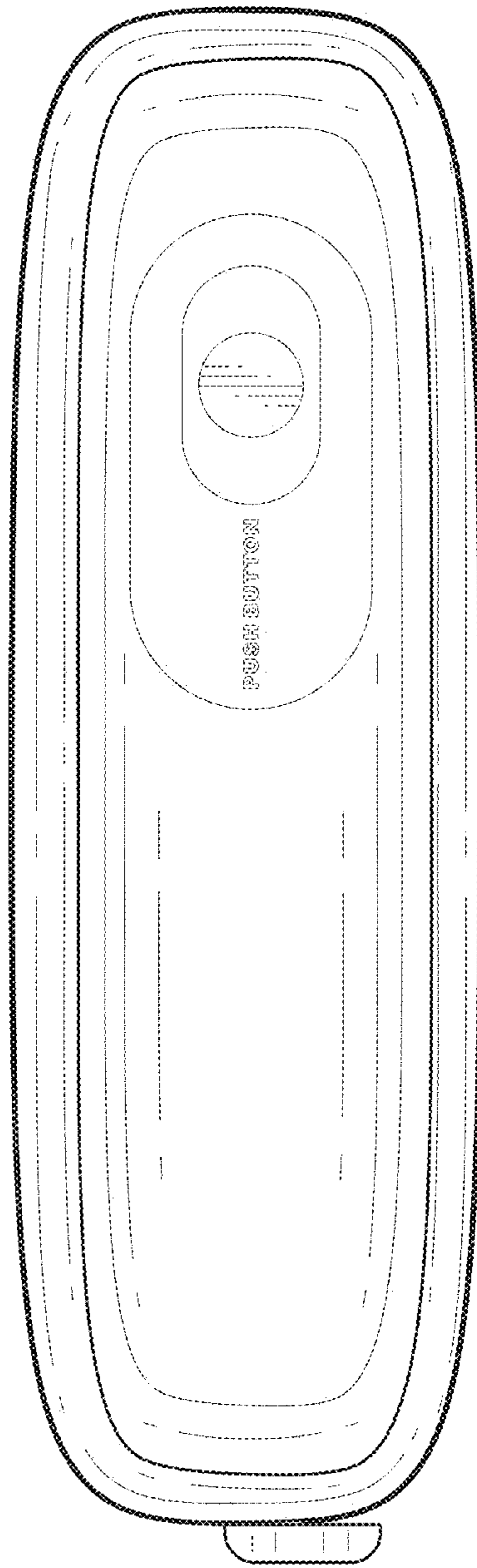

FIG. 6

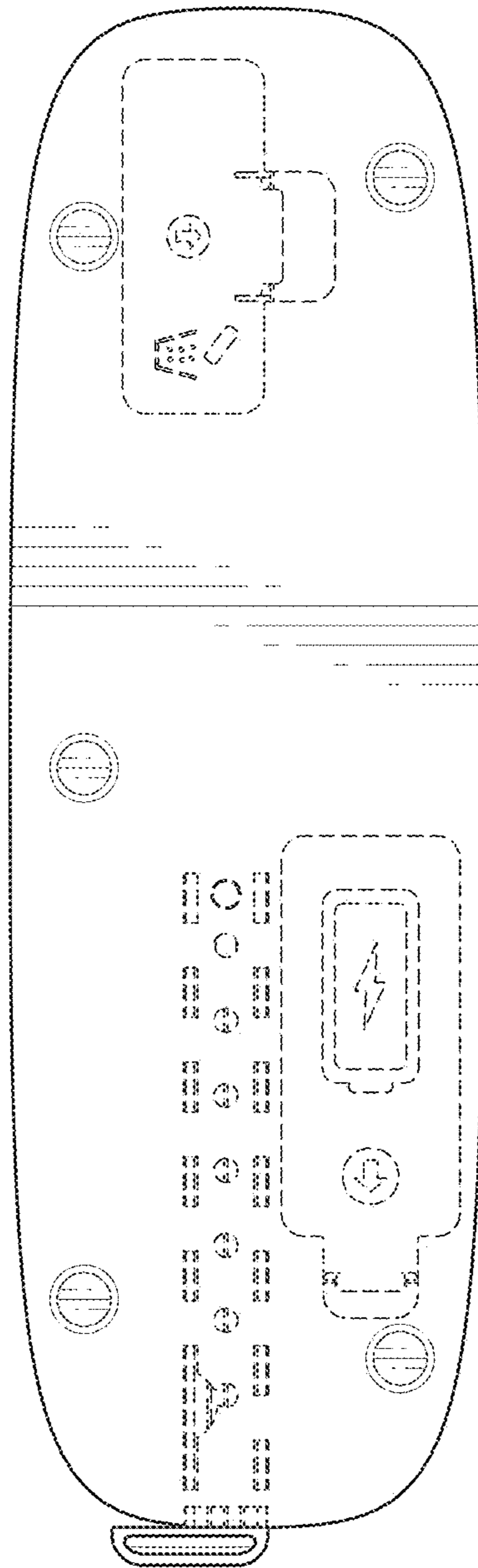

FIG. 7