



US00D896663S

(12) **United States Design Patent** (10) **Patent No.:** **US D896,663 S**
Chapman et al. (45) **Date of Patent:** **** Sep. 22, 2020**

(54) **SENSOR HOUSING**

F21V 23/0442; F21V 21/30; F21W 2131/10; G08B 13/19; G08B 13/193; G08B

(71) Applicant: **Topcon Positioning Systems, Inc.**,
Livermore, CA (US)

(Continued)

(72) Inventors: **Angus Chapman**, Brisbane (AU);
Reilly Edwards, Brisbane (AU); **Craig
Roughan**, Brisbane (AU)

(56)

References Cited

U.S. PATENT DOCUMENTS

(73) Assignee: **Topcon Positioning Systems, Inc.**,
Livermore, CA (US)

4,315,594 A 2/1982 Niederost
D316,713 S 5/1991 Sun

(Continued)

(**) Term: **15 Years**

FOREIGN PATENT DOCUMENTS

(21) Appl. No.: **29/675,182**

EP 0014251 A1 8/1980
EP 2840559 A1 2/2015
EP 3270117 A1 1/2018

(22) Filed: **Dec. 28, 2018**

(51) **LOC (12) Cl.** **10-04**

(52) **U.S. Cl.**

USPC **D10/65**

(58) **Field of Classification Search**

USPC D10/46, 65, 70

CPC G08G 1/096883; G08G 1/096872; G08G

1/096775; G08G 1/0969; G08G 9/00;

G08G 5/04; G08G 5/0013; G01V 8/20;

G01J 5/02; G01J 5/023; G01J 5/24; G01J

5/10; G01J 5/20; G01J 5/0235; G01J

5/08; G01J 5/0853; G01J 5/33; G01J

5/34; G01J 5/0022; G01J 5/22; G01J

5/0295; G01J 5/12; G01J 2005/068; G01J

2005/345; G01N 21/3504; G01N 21/35;

G01S 3/043; G01S 15/04; G01S 5/025;

G01S 1/70; G01S 1/08; G01S 13/74;

G01S 19/42; G01S 13/79; G01S 13/9303;

G01S 13/781; G01S 13/782; Y10S

250/01; H01L 37/00; H01L 37/02; H04N

5/33; G01P 3/50; G01P 15/18; G01C

21/3664; G01C 21/26; G01C 21/16;

G01C 21/3688; G01C 21/30; G01C

17/00; G01C 21/00-21/3697; G01C

22/00-22/025; G01C 23/00-23/005; G06F

3/0482; G06F 2203/04801; G06F 3/00;

G06F 3/027; F21S 8/033; F21V 17/02;

OTHER PUBLICATIONS

Notice of Allowance dated Feb. 5, 2020, in connection with U.S.
Appl. No. 29/675,183, filed Dec. 28, 2018, 9 pgs.

(Continued)

Primary Examiner — Antoine Duval Davis

(74) *Attorney, Agent, or Firm* — Chiesa Shahinian &
Giantomasi PC

(57)

CLAIM

The ornamental design for a sensor housing, as shown and
described.

DESCRIPTION

FIG. 1 is a rear perspective view of a sensor housing
according to our design;

FIG. 2 is a front view thereof;

FIG. 3 is a rear view thereof;

FIG. 4 is a left side view thereof;

FIG. 5 is a right side view thereof;

FIG. 6 is a top view thereof; and,

FIG. 7 is a bottom view thereof.

(Continued)

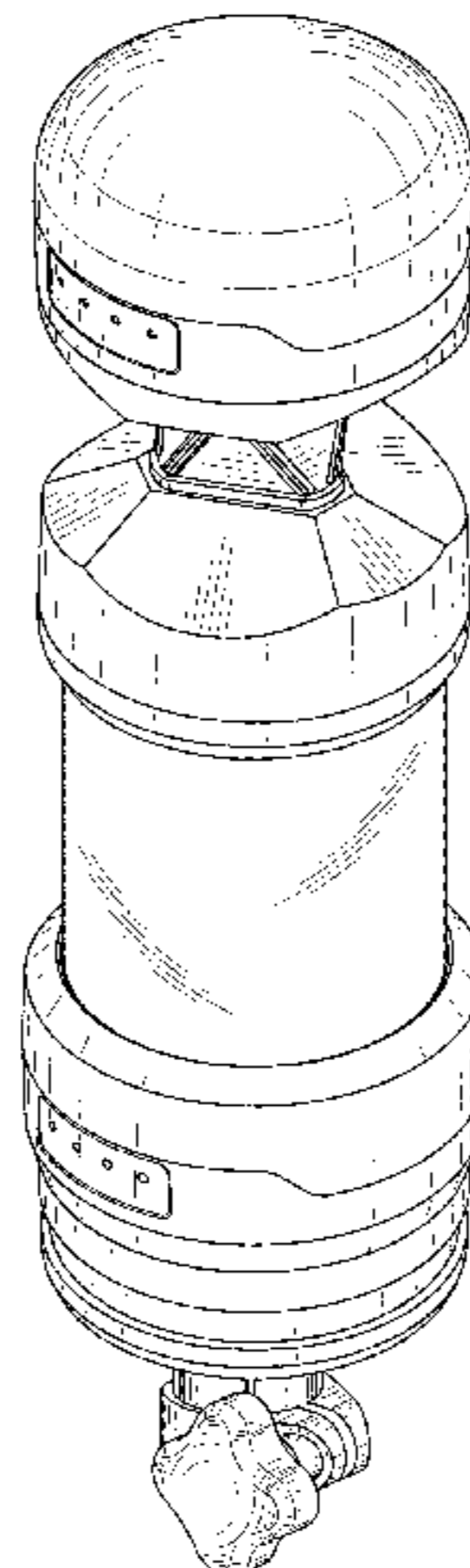

The broken lines shown in the drawings depict environment that forms no part of the claimed design.

1 Claim, 6 Drawing Sheets

(58) **Field of Classification Search**

CPC 13/1645; G08B 17/12; G08B 13/00–13/26;
G08B 29/00–29/28; B64D 45/00; B64D
25/00; H04L 69/08; H04B 1/59; H04Q
11/00

See application file for complete search history.

(56)

References Cited

U.S. PATENT DOCUMENTS

D363,930	S	11/1995	Bailey et al.	
6,598,835	B2	7/2003	Minnick	
7,114,388	B1	10/2006	French et al.	
D568,183	S *	5/2008	Ishii	D10/65
D594,399	S	6/2009	Johnson	
D598,480	S	8/2009	Kanemitsu	
D623,500	S	9/2010	Langner et al.	
D661,980	S	6/2012	Rocquet	
D673,029	S	12/2012	Apestequia et al.	
D695,591	S	12/2013	Ackerman et al.	
D697,438	S *	1/2014	Rector, III	D10/65
D716,640	S	11/2014	Martinson	
D732,926	S	6/2015	Booth et al.	
D744,316	S	12/2015	Nook et al.	
D745,369	S	12/2015	Tungesvick	
D755,705	S	5/2016	Shin	
D757,520	S	5/2016	Pratt	
9,354,158	B1	5/2016	Van Dijk et al.	
D766,069	S	9/2016	Miller	
D767,218	S	9/2016	Hickling	
D772,737	S *	11/2016	Robinson	D10/65
D779,921	S	2/2017	Del Rossa	

D779,922	S	2/2017	Del Rossa	
D801,834	S *	11/2017	Briheim	D10/65
D803,908	S	11/2017	Yamaguchi et al.	
D822,081	S	7/2018	Yamaguchi et al.	
D831,467	S	10/2018	Crichton et al.	
D834,922	S	12/2018	Russo	
D838,581	S	1/2019	Huang et al.	
D859,968	S	9/2019	West	
D860,765	S	9/2019	Tsay	
D863,936	S	10/2019	Pratt et al.	
D871,894	S	1/2020	Brett	
2003/0056868	A1	3/2003	Gentry	
2003/0137658	A1	7/2003	Ohtomo et al.	
2016/0180999	A1	6/2016	Rattner et al.	
2018/0017414	A1	1/2018	Binder et al.	

OTHER PUBLICATIONS

Notice of Allowance dated Feb. 6, 2020, in connection with U.S. Appl. No. 29/675,179, filed Dec. 28, 2018, 9 pgs.

Non-Final Office Action dated Mar. 6, 2020, in connection with U.S. Appl. No. 16/235,622, filed Dec. 28, 2018, 16 pgs.

International Search Report dated Mar. 16, 2020, in connection with International Patent Application No. PCT/US2019/062319, filed Nov. 20, 2019, 18 pgs.

Topcon Positioning Systems, Inc., “Z-Stack Vibration Mount Assembly,” Technical Data Sheet, Feb. 2020, P/N: 1037639-01 Rev. A, 2 pgs.

Topcon Positioning Systems, Inc., “GR-i3 Integrated GNSS Receiver and Antenna,” Technical Data Sheet, Feb. 2020, P/N: 1020457-01 Rev. A, 2 pgs.

Topcon Positioning Systems, Inc., “RP-i3 Machine Control Prism Assembly,” Technical Data Sheet, Feb. 2020, P/N: 1037638-01 Rev. A, 1 pg.

Topcon Positioning Systems, Inc., “PZS-i3 Positioning Zone Sensor,” Technical Data Sheet, Feb. 2020, P/N: 1037637-01 Rev. A, 2 pgs.

* cited by examiner

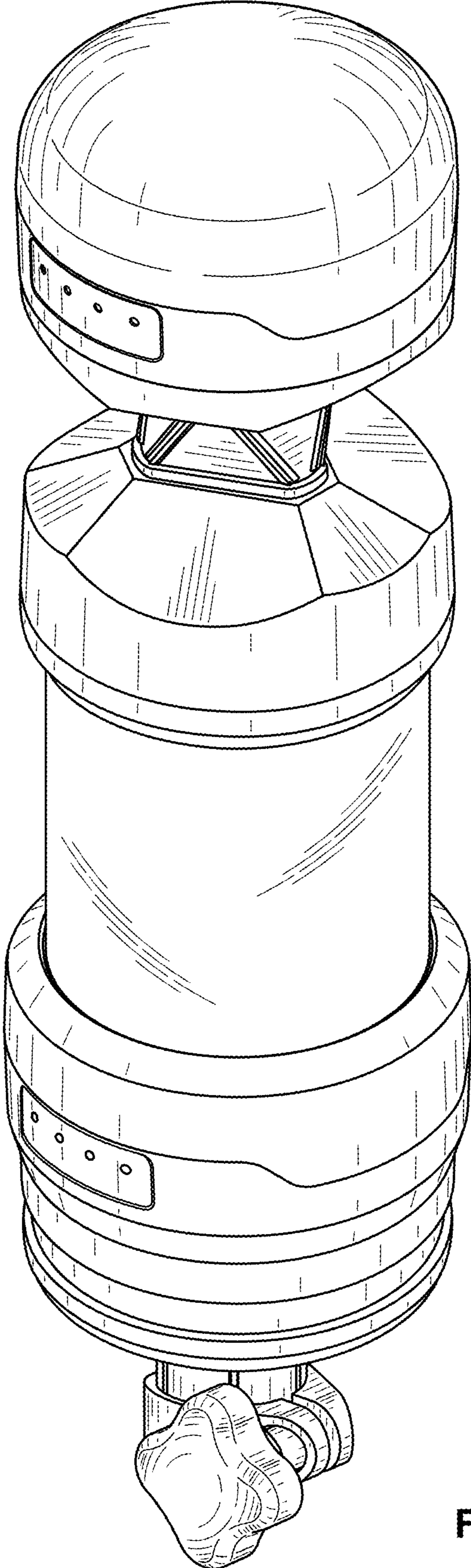

FIG. 1

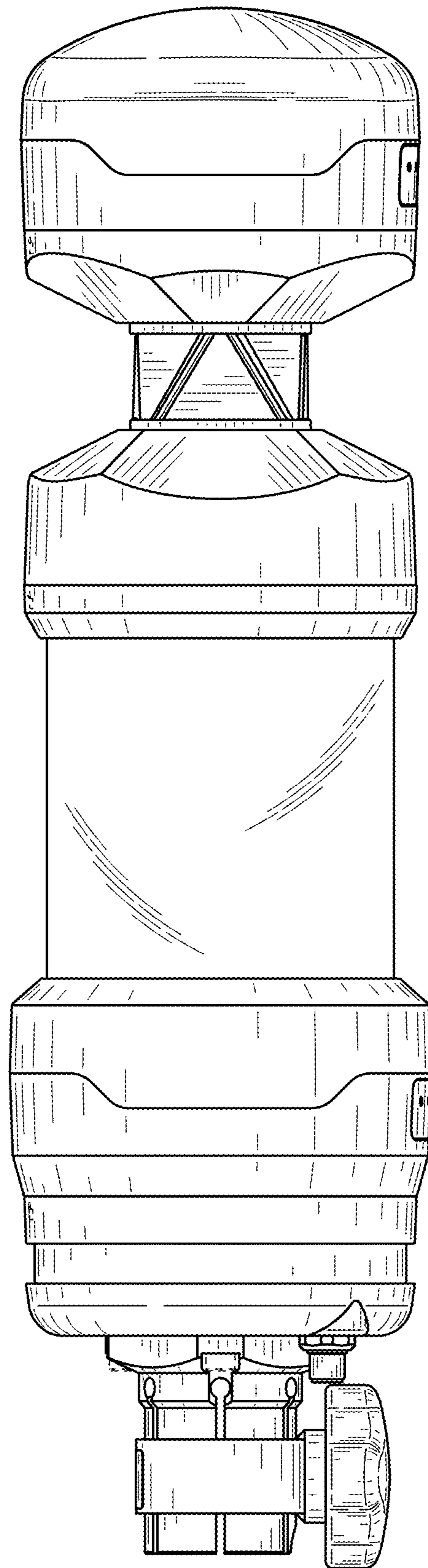

FIG. 2

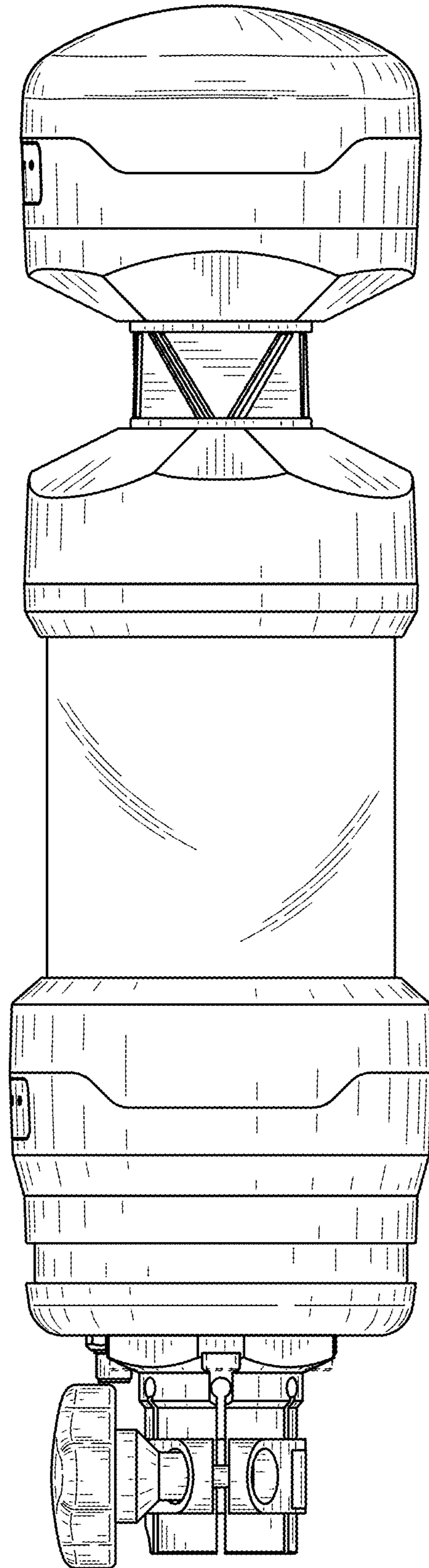

FIG. 3

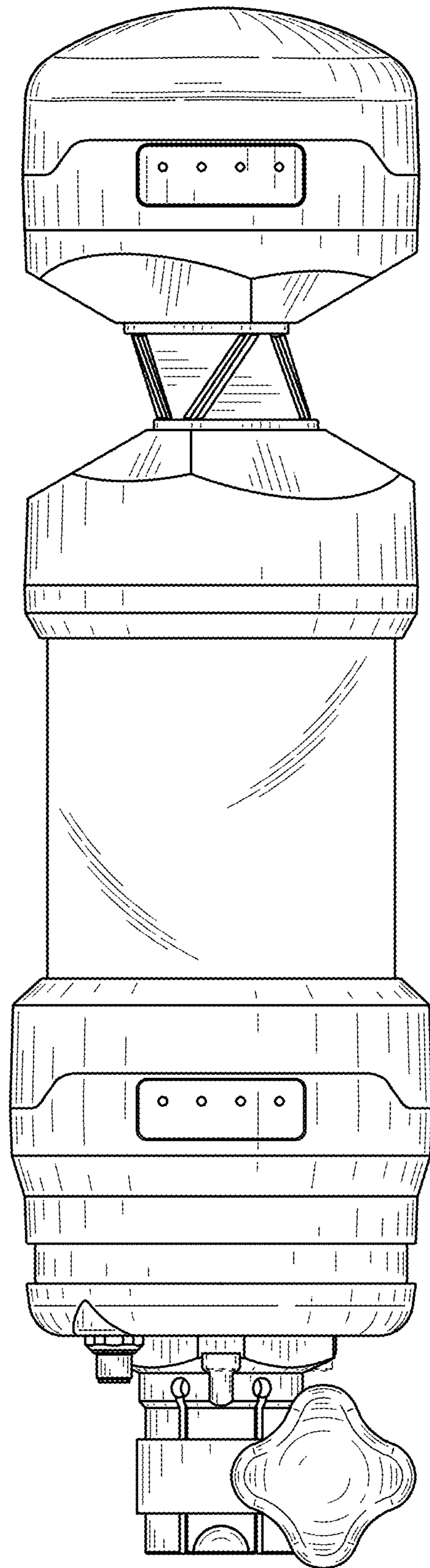

FIG. 4

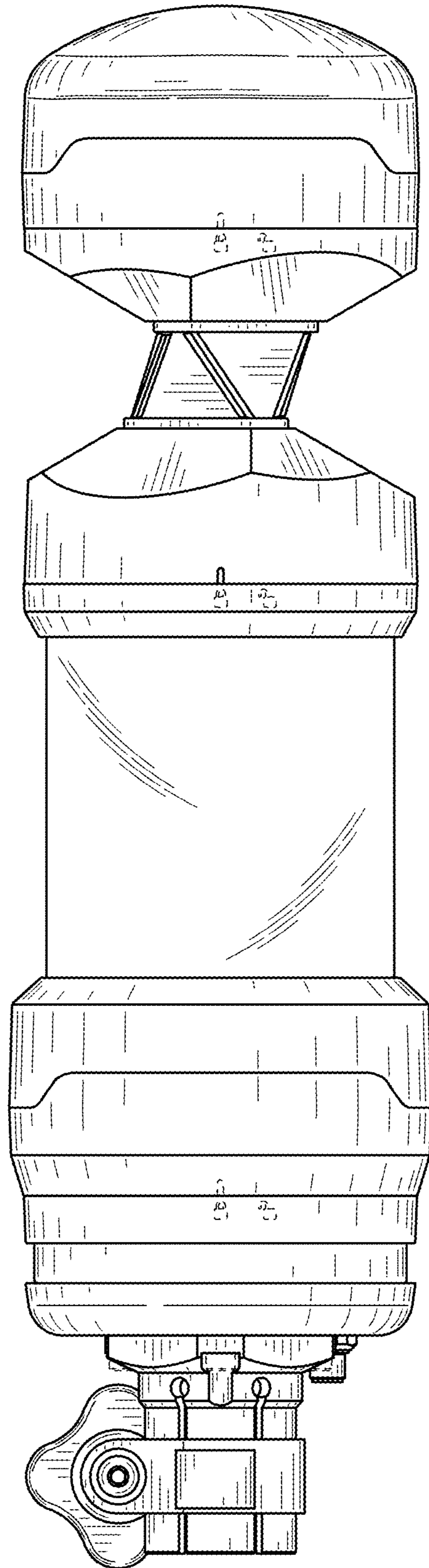

FIG. 5

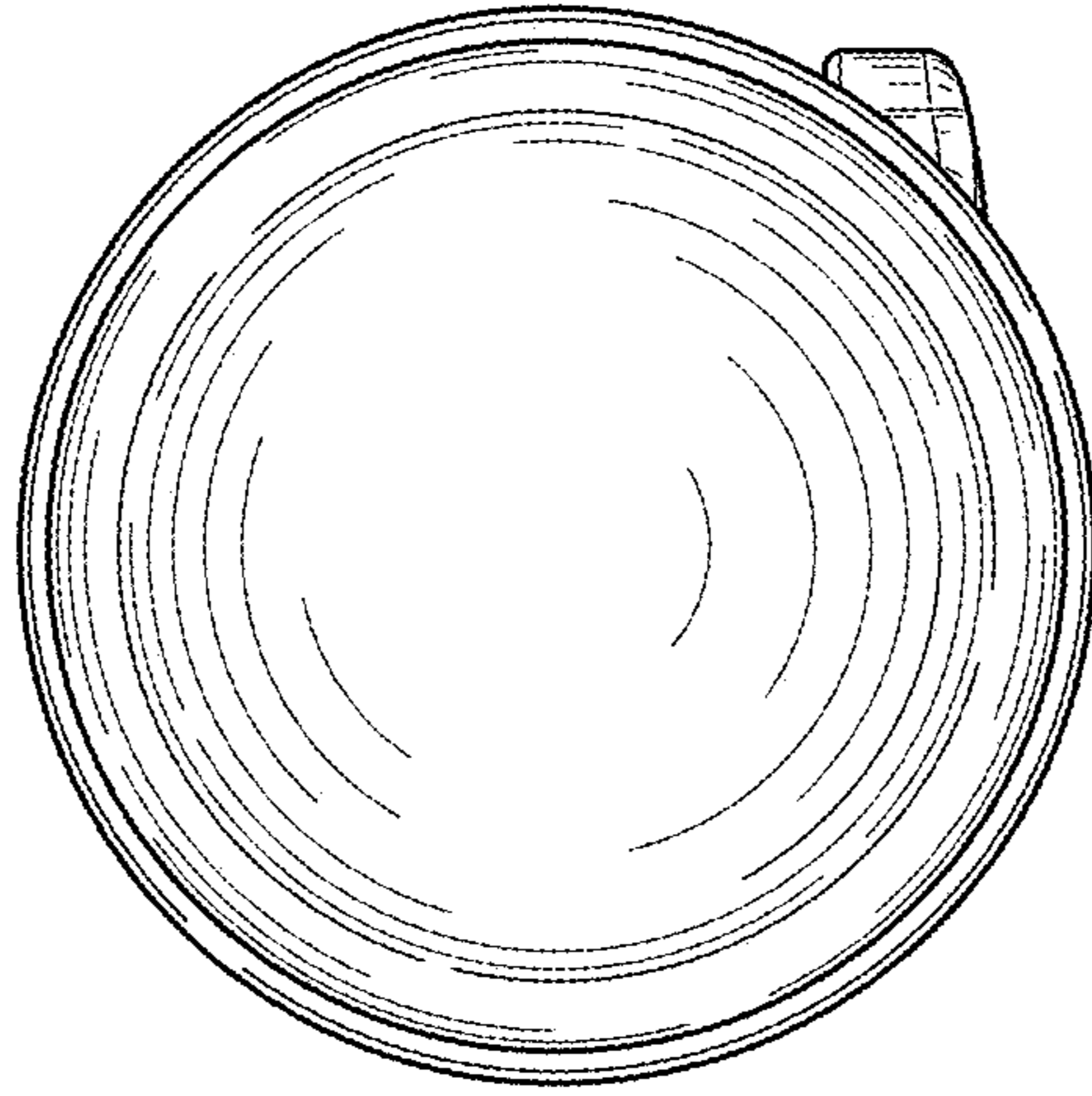

FIG. 6

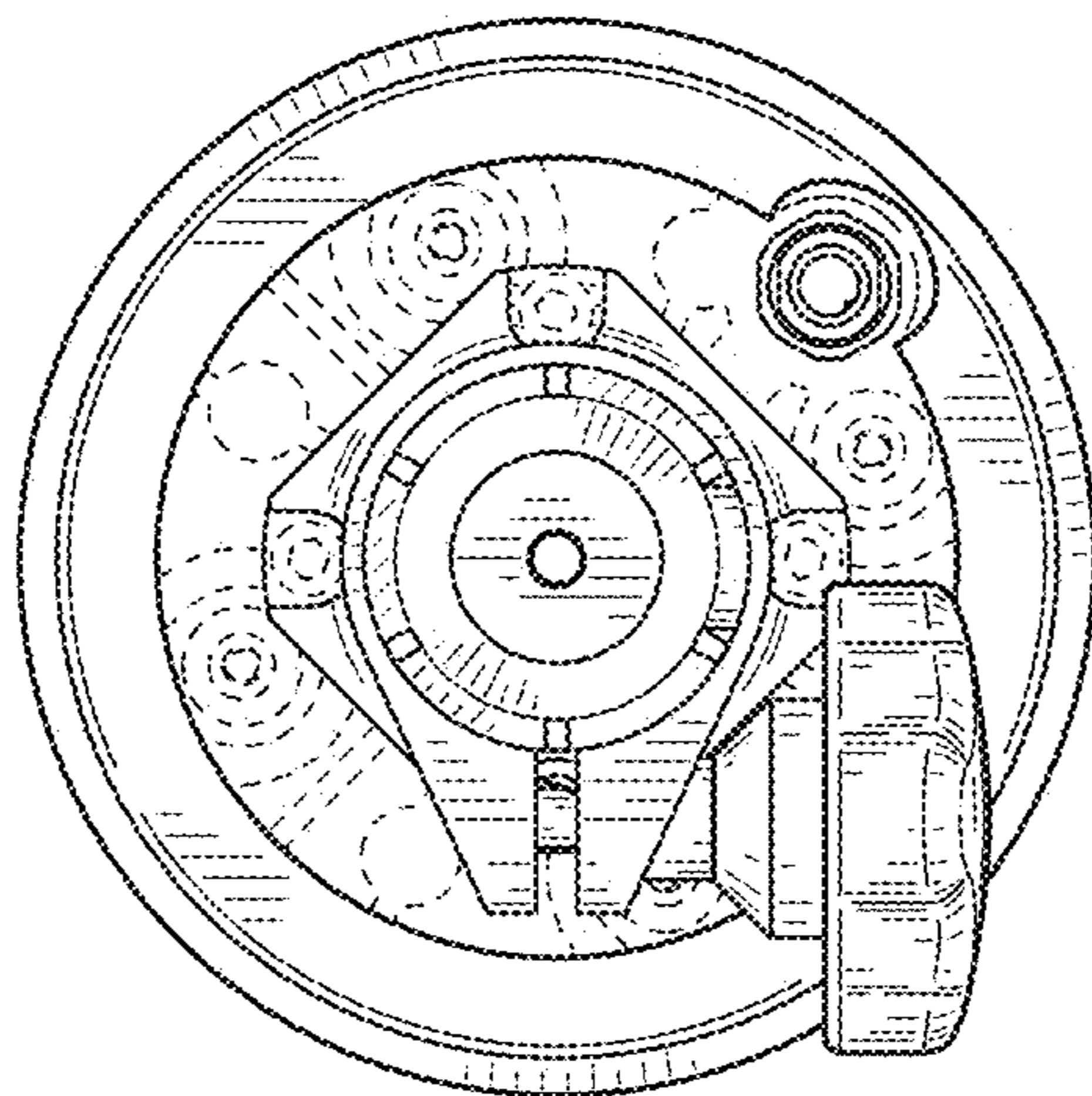

FIG. 7