

US00D896401S

(12) **United States Design Patent** (10) **Patent No.:** **US D896,401 S**
Oldroyd et al. (45) **Date of Patent:** **** Sep. 15, 2020**

(54) **BEAM**

(71) Applicant: **IsoTruss Industries LLC**, Provo, UT (US)

(72) Inventors: **Jordan W. Oldroyd**, Provo, UT (US);
Jonathan J. Curtis, Provo, UT (US);
Carter J. Smith, Orem, UT (US);
Nathan D. Rich, Orem, UT (US)

(73) Assignee: **IsoTruss Industries LLC**, Provo, UT (US)

(**) Term: **15 Years**

(21) Appl. No.: **29/639,489**

(22) Filed: **Mar. 6, 2018**

(51) **LOC (12) Cl.** **25-01**

(52) **U.S. Cl.**
USPC **D25/128**

(58) **Field of Classification Search**
USPC D25/126, 127, 128, 129, 130, 131, 132,
D25/133, 134, 135, 136
CPC .. B64G 9/00; B64G 1/222; E04B 1/19; E04B
2001/1927; E04B 2001/1984; E04B
2001/1987; E04B 1/1903; E04B 1/1906;
E04B 1/3441; E04B 2001/1933; E04B
2001/1936; E04B 2001/1957; E04B
2001/1963; E04B 2001/1972; E04B
2001/1975; B21F 27/12; B21F 27/128;
B21F 27/20; B21F 3/02; E04C 2/36;
E04C 2/365; E04C 3/291; E04C 3/08;
E04C 2003/0495; E04H 12/182; E04H
12/10; E04H 12/02; E04H 12/18; E04H
12/185; E04H 12/2223

See application file for complete search history.

1,922,269 A	8/1933	Wickwire, Jr.
2,106,674 A	1/1938	Busch
2,158,266 A	5/1939	Aldrich
2,362,688 A	11/1944	Dunn
2,879,687 A	3/1959	Leimbach et al.
2,931,467 A	4/1960	Fentiman
2,941,440 A	6/1960	Scanlon
3,007,497 A	11/1961	Shobert
3,062,336 A	11/1962	Baxter
3,495,687 A	2/1970	Shirley, Jr. et al.
3,496,687 A	2/1970	Greenberg et al.
3,501,880 A	3/1970	Bosch
3,705,473 A	12/1972	Yeffal-Rueda
3,798,864 A	3/1974	Georgii
3,800,414 A	4/1974	Shattes et al.
3,970,116 A	7/1976	Takada et al.
3,992,118 A	11/1976	Siegers
4,077,828 A	3/1978	Strom
4,109,038 A	8/1978	Hayashi et al.
4,137,354 A	1/1979	Mayes, Jr. et al.
4,241,117 A	12/1980	Figge
4,253,284 A	3/1981	Bliss
4,260,143 A	4/1981	Kliger
4,321,854 A	3/1982	Foote et al.
4,337,560 A	7/1982	Slysh
4,347,287 A	8/1982	Lewis et al.
4,366,658 A	1/1983	Maistre
4,380,483 A	4/1983	Kliger
4,471,548 A	9/1984	Goudie
4,473,217 A	9/1984	Hashimoto
4,475,232 A	10/1984	Shaw
4,475,323 A	10/1984	Schwartzberg et al.
4,494,436 A	1/1985	Kruesi
4,539,786 A	9/1985	Nelson
4,557,097 A	12/1985	Mikulas, Jr. et al.
4,655,022 A	4/1987	Natori
4,686,134 A	8/1987	Ono
4,722,162 A	2/1988	Wilensky
4,734,146 A	3/1988	Halcomb et al.
4,786,341 A	11/1988	Kobatake et al.
4,803,824 A	2/1989	Coppa
4,912,889 A	4/1990	Palumbo
4,916,997 A	4/1990	Spain
4,951,440 A	8/1990	Staeger
4,986,863 A	1/1991	Denoel et al.
5,003,736 A	4/1991	Okazaki et al.
5,016,516 A	5/1991	Aldrich et al.
5,048,441 A	9/1991	Quigley
5,152,326 A	10/1992	Vohringer
5,184,444 A	2/1993	Warden
5,197,254 A	3/1993	Smith
5,320,696 A	6/1994	McConnell et al.
5,356,234 A	10/1994	Vangool

(56) **References Cited**

U.S. PATENT DOCUMENTS

1,465,307 A	8/1923	Keogan
1,613,788 A	1/1927	Dawson et al.
1,798,064 A	3/1931	Chorlton et al.

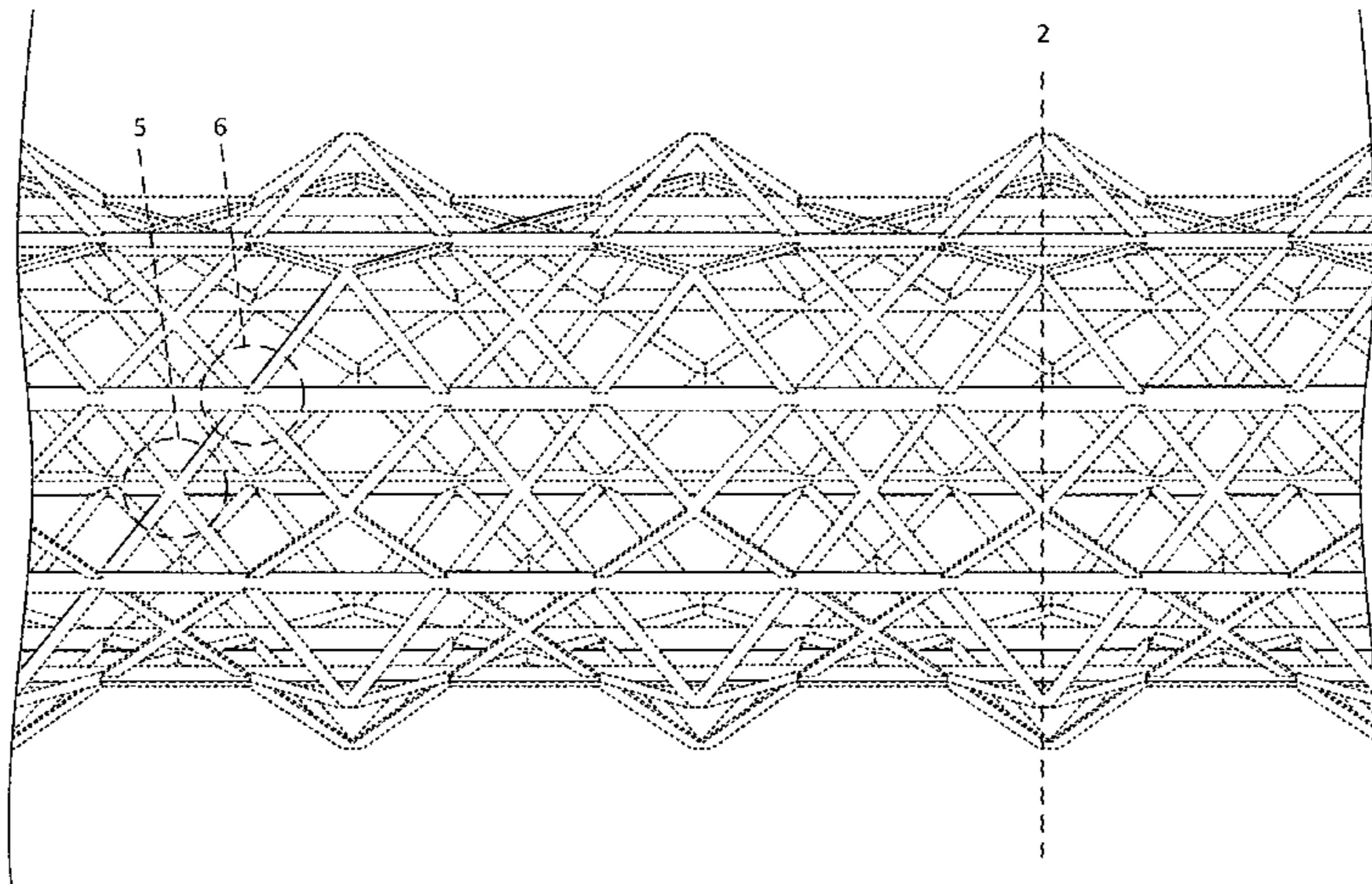

5,388,538 A 2/1995 Chekroune et al.
 5,463,970 A 11/1995 Hartlmeier et al.
 5,505,035 A 4/1996 Lalvani
 5,556,677 A 9/1996 Quigley et al.
 5,651,228 A 7/1997 Zeigler
 5,846,364 A 12/1998 Policelli
 D408,665 S * 4/1999 Von Gunten D25/69
 5,921,048 A 7/1999 Francom et al.
 5,962,150 A 10/1999 Priluck
 5,985,304 A 11/1999 Van Voris et al.
 6,076,324 A 6/2000 Daily et al.
 6,264,684 B1 7/2001 Banas et al.
 6,321,502 B1 11/2001 Castano
 6,431,497 B1 8/2002 Hoyt et al.
 6,439,096 B1 8/2002 Mungalov et al.
 6,647,852 B1 11/2003 Freitas et al.
 6,910,308 B2 6/2005 Cadogan et al.
 7,132,027 B2 11/2006 Jensen
 7,155,872 B2 1/2007 Francom
 7,318,303 B1 1/2008 Kling
 D604,452 S * 11/2009 Smith D26/118
 7,694,465 B2 4/2010 Pryor
 7,694,486 B2 4/2010 Murphy et al.
 D624,201 S * 9/2010 Hendricks D25/100
 8,042,305 B2 10/2011 Pryor et al.
 8,320,727 B1 11/2012 Jacobsen et al.
 D672,478 S * 12/2012 Hendricks D25/100
 8,444,900 B2 5/2013 Wilson et al.
 D697,833 S * 1/2014 Garcia D11/146
 8,621,822 B2 1/2014 Brockwell
 8,745,958 B2 6/2014 Kang et al.
 D714,066 S * 9/2014 Thuma D5/99
 D722,180 S * 2/2015 Gowrie D25/22
 9,116,428 B1 8/2015 Jacobsen et al.
 D753,844 S * 4/2016 Gervais D25/100
 D759,885 S * 6/2016 Nishimoto D26/118
 D783,878 S * 4/2017 Lava D26/81
 10,557,267 B2 2/2020 Oldroyd et al.
 2002/0081936 A1 6/2002 Snelson
 2002/0124518 A1 9/2002 Warren et al.
 2004/0247866 A1 12/2004 Jensen
 2005/0115186 A1 6/2005 Jensen et al.
 2007/0095012 A1 5/2007 Kang et al.
 2007/0151202 A1 7/2007 Cox et al.
 2010/0071300 A1 3/2010 Lee et al.
 2011/0117315 A1 5/2011 Kang et al.
 2012/0151868 A1 6/2012 Kang et al.
 2012/0225237 A1 9/2012 Brockwell
 2013/0080123 A1 3/2013 Webbink et al.
 2013/0167462 A1 7/2013 Wilson et al.
 2013/0243989 A1 9/2013 Ridges et al.
 2013/0276308 A1 10/2013 Kang et al.
 2013/0322955 A1 12/2013 Ma
 2014/0182232 A1 7/2014 Holt
 2014/0288650 A1 9/2014 Hunt
 2014/0302261 A1 10/2014 Cheung et al.
 2017/0100855 A1 4/2017 Taylor
 2017/0173894 A1 6/2017 Konrad et al.
 2017/0306923 A1 10/2017 Berthilsson
 2018/0251979 A1 9/2018 Oldroyd et al.
 2018/0251980 A1 9/2018 Oldroyd et al.

FOREIGN PATENT DOCUMENTS

FR 1377290 A 11/1964
 GB 1251343 10/1971
 GB 2049613 A 12/1980
 GB 2164674 A 3/1986
 JP 59-55946 A 3/1984
 JP S6215695 B2 4/1987
 WO 98/45556 A1 10/1998
 WO 02/10535 A2 2/2002

OTHER PUBLICATIONS

Tabata, M. et al., "Shape Adjustment of a Flexible space Antenna Reflector": Mitsubishi Electric Corporation, Center Research Laboratory, Hyogo, Japan, pp. 393-405, presented at the Second Joint US/ Japan Conference on Adaptive Structures Nov. 12-14, 1991.

Tanaka, M. et al., "On Damping Enhancement of LSS Coupled with the Antenna Pointing System" Toshiba Corporation, Kawasaki, Japan, pp. 510-524 presented at the First Joint US/ Japan Conference on Adaptive Structures Nov. 13-15, 1990.
 Tanaka, M. et al., "Stochastic Approach to Static Control of Adaptive Truss under Imperfection of Adjustable Member Lengths" Department of Mechanical Engineering, Osaka University, Osaka, Japan, pp. 406-418, presented at the Second Joint US/ Japan Conference on Adaptive Structures Nov. 12-14, 1991.
 Tanaka, M. et al., Kinematics of Adaptive Truss Permitting Modal Offset (configuration and workspace reach), Osaka university, Department of Mechanical engineering, Osaka, Japan, pp. 691-714, presented at the First Joint US/ Japan Conference on Adaptive Structures Nov. 13-15, 1990.
 Tidwell, PH et al., "Kinematic Analysis of Generalized Adaptive Trusses" Mechanical Engineering Department, Virginia Polytechnic Institute and State University, Blacksburg, Virginia, pp. 772-791 presented at the First Joint US/ Japan Conference on Adaptive Structures Nov. 13-15, 1990.
 Troidl H. et al., "Dynamic Tests on the NASA Langley CSI Evolutionary Model" AGARD Conference proceedings 531 Smart Structures for Aircraft and Spacecraft held in Germany, Oct. 1992, pp. 4-1 to 4-9.
 Wada, B. K. et al., "Application of Adaptive Structures for the Control of Truss Structures" Jet Propulsion Laboratory, California Institute of Technology Pasadena, California, pp. 123-131, presented at the Second Joint US/ Japan Conference on Adaptive Structures Nov. 12-14, 1991.
 Wada, Ben K. et al., "Advances in Adaptive Structures at Jet Propulsion Laboratory" AGARD Conference proceedings 531 Smart Structures for Aircraft and Spacecraft held in Germany, Oct. 1992, Applied Mechanics Technologies Section, pp. 28-1 to 28-13, Pasadena, California, USA.
 Yokoi, K et al., "A Method for Solving Inverse Kinematics of Variable Structure Truss Arm with High Redundancy" Robotics Department, Mechanical Engineering Laboratory, Tsukuba, Ibaraki, Japan, pp. 606-620, presented at the Second Joint US/ Japan Conference on Adaptive Structures Nov. 12-14, 1991.
 Yoshida, K et al., "Cosmo-Lab Concept: A Cooperation of Space Robots and Structures" Department of Mechanical Engineering Science, Tokyo Institute of Technology, Tokyo, Japan, pp. 59-76, presented at the Second Joint US/ Japan Conference on Adaptive Structures Nov. 12-14, 1991.
 U.S. Patent No. 31,777, "Iron Masts, Steeps, &c," issued to E.S. Boynton, patented on Mar. 26, 1861, 5 pages.
 37th AIAA/ASME/ASCE/AHS/ASC Structures, Structural Dynamics, and Materials Conference, Apr. 15-17, 1996, Salt Lake City, Utah, U.S.A., pp. 1868-1873.
 Non Final Office Action for U.S. Appl. No. 15/913,836, dated Feb. 6, 2019, 11 pages.
 Asay: "Bending Behavior of Carbon/Epoxy Composite IsoBeam Structures," Thesis, Mar. 8, 2016, 257 pages.
 Hinds: "Shear-Dominated Bending Behavior of Carbon/Epoxy Composite Lattice IsoBeam Structures"; Thesis, Apr. 11, 2016, 161 pages.
 Swanson, A. D. et al., "Zero-Gravity Dynamics of Space Structures in Parabolic Aircraft Flight" flight dynamics laboratory, air force Wright research and development center, Wright-Patterson Air Force Base, Ohio, pp. 952-965 presented at the First Joint US/ Japan Conference on Adaptive Structures Nov. 13-15, 1990.
 AGARD Conference Proceedings 531, Smart Structures for Aircraft and Spacecraft, Oct. 5-7, 1992, Lindau, Germany, 389 pages.
 Wada et al.: First Joint U.S./Japan Conference on Adaptive Structures, Nov. 13-15, 1990, Maui, Hawaii, U.S.A., Technomic Publishing Co., Inc.
 Matsuzaki et al.: Second Joint Japan/U.S. Conference on Adaptive Structures, Nov. 12-14, 1991, Nagoya, Japan, Technomic Publishing Co., Inc., 21 pages.
 Allen, J. J. et al., "The Sandia Structural Control Experiments" Sandia National Laboratories, Albuquerque, New Mexico, pp. 928-951 presented at the First Joint US/ Japan Conference on Adaptive Structures Nov. 13-15, 1990.

- Anderson, W.W. et al., The NASA-LaRC Controls-Structure Interaction Technology Program Guidance and Control Division, NASA, Hampton, Virginia, pp. 15-31, presented at the Second Joint US/ Japan Conference on Adaptive Structures Nov. 12-14, 1991.
- Beer, F. et al. "Space Trusses"; Vector Mechanics for Engineers Statics Third Edition, pp. 222-228, 1977.
- Beth, F. et al., "On Possible Applications of Smart Structures to Control of Space Systems" AGARD Conference proceedings 531 Smart Structures for Aircraft and Spacecraft held in Germany, Oct. 1992, pp. 26-1 to 26-14.
- Breitbach, E. J., "Research Status on Adaptive Structures in Europe" Institute of Aeroelasticity, Goettingen, Germany, pp. 32-48, presented at the Second Joint US/ Japan Conference on Adaptive Structures Nov. 12-14, 1991.
- Bronowicki, A.J. et al., "ACESA Structural Control System Design" TRW Space and Technology Group, Redondo Beach, California, pp. 373-401 presented at the First Joint US/ Japan Conference on Adaptive Structures Nov. 13-15, 1990.
- Chen, G.S. et al., "On an Adaptive Truss Manipulator Space Crane Concept" Jet Propulsion Laboratory, California Institute of Technology, Pasadena, California, pp. 726-742, presented at the First Joint US/ Japan Conference on Adaptive Structures Nov. 13-15, 1990.
- Crawley, Edward et al., "Intelligent Structures a Technology Overview and Assessment": AGARD Conference proceedings 531 Smart Structures for Aircraft and Spacecraft held in Germany, Oct. 1992, Space Engineering Research Center, MIT, pp. 6-1 to 6-16, Cambridge, Massachusetts, USA.
- Darooka et al, "Advanced Space Structure Concepts and Their Development", American Institute of Aeronautics and Astronautics, Structures, Structural Dynamics, and Materials Conference and Exhibit, 42nd Seattle Washington, Apr. 16-19, 2001, pp. 1-10.
- Das, Alok et al., "Adaptive Structures for Spacecraft a USAF Perspective" AGARD Conference proceedings 531 Smart Structures for Aircraft and Spacecraft held in Germany, Oct. 1992 pp. 3-1 to 3-3-13.
- Das, SK et al., "A Mathematical Basis for the Design and Design Optimization of Adaptive Trusses in Precision Control" Duke University, Durham North Carolina, pp. 660-690 presented at the First Joint US/ Japan Conference on Adaptive Structures Nov. 13-15, 1990.
- D'Eleuterio, G. M. T., "Articulatory Dynamics of Variable-Geometry Truss Structures" Institute for Aerospace Studies, University of Toronto, Downsview, Ontario, Canada, pp. 621-640, presented at the Second Joint US/ Japan Conference on Adaptive Structures Nov. 12-14, 1991.
- Fanson, J.L. et al., "Damping and Structural Control of the JPL Phase 0 Testbed Structure" Jet Propulsion Laboratory California Institute of Technology, Pasadena, California pp. 510-524 presented at the First Joint US/ Japan Conference on Adaptive Structures Nov. 13-15, 1990.
- Fiber Innovations, Inc. "Braided Composite Structures", 6 pages.
- Fiber Innovations, Inc. Brochure, 4 pages.
- Fisher, S., "Real-Time Modifications of an Orbiting Spacecraft to Excite Vibrations Observed by a Ground-Based Laser Radar" Naval Research Laboratory, Washington, D.C., pp. 479-492, presented at the Second Joint US/ Japan Conference on Adaptive Structures Nov. 12-14, 1991.
- Hibbeler, RC: "Space Trusses" Engineering Mechanics Statics, Chapter 6, Seventh Edition, pp. 267-270, Prentice-Hall, Englewood Cliffs, New Jersey, 1995.
- Hughes, P.C., "Trussarm—A Variable-Geometry—Truss Manipulator" University of Toronto, Institute for Aerospace Studies, Toronto, Canada, pp. 715-725 presented at the First Joint US/ Japan Conference on Adaptive Structures Nov. 13-15, 1990.
- Jensen, D. W. et al., "Dynamic Characterization of a Composite Lattice Structure with an Integrated Fiber-Optic Strain-Sensor" The Pennsylvania State University, Department of Aerospace Engineering, University Park, Pennsylvania, pp. 828-845, presented at the First Joint US/ Japan Conference on Adaptive Structures Nov. 13-15, 1990.
- Jensen, D. W. et al. "On the Structural Efficiency of Three-Dimensional Isogrid Designs"; 37th AIAA/ASME/ASCE/AHS/ASC Structures, Structural Dynamics, and Materials Conference; Apr. 15-17, 1996.
- Jensen, W. D. et al., "Validation of Active Strain Measurements in Composites Using Mach-Zehnder Interferometry with Embedded Optical Fibers" the Pennsylvania State University, Department of Aerospace Engineering, University Park, Pennsylvania, pp. 771-788, presented at the Second Joint US/ Japan Conference on Adaptive Structures Nov. 12-14, 1991.
- Kuo, C.P. et al., "Optimal Acuator Placement on an Active Reflector Using a Modified Simulated Annealing Technique" Applied Mechanics Technologies Section, Jet Propulsion Laboratory, California Institute of Technology, Pasadena, California, pp. 1056-1068 presented at the First Joint US/ Japan Conference on Adaptive Structures Nov. 13-15, 1990.
- Kuwao, F. et al., "Quasi-Static Shape Estimation and Control of Adaptive Truss Structures Using Internal Displacement Structures" Applied mechanics Technologies Section, Jet Propulsion Laboratory, California Institute of Technology, Pasadena, California, pp. 375-392, presented at the Second Joint US/ Japan Conference on Adaptive Structures Nov. 12-14, 1991.
- Larson, L. B. et al., "An Experimental 10-Meter Space Truss with Tendon Control" School of Civil and Environmental Engineering, Cornell University Ithaca, New York, pp. 227-244, presented at the Second Joint US/ Japan Conference on Adaptive Structures Nov. 12-14, 1991.
- Lawrence, C.R. et al., "Active Member Vibration Control Experiment in a KC-135 Reduced Gravity Environment" Jet Propulsion Laboratory, California Institute of Technology, Pasadena, California, pp. 987-1003 presented at the First Joint US/ Japan Conference on Adaptive Structures Nov. 13-15, 1990.
- Macleon, B.J. et al., "Development of a Shape Memory Material Actuator for Adaptive Truss Applications" Materials and Structures Group Research & Technology, Martin Marietta Space Systems Denver, Colorado, pp. 1038-1055 presented at the First Joint US/ Japan Conference on Adaptive Structures Nov. 13-15, 1990.
- Matsuzaki, Y. et al., "Application of Fuzzy Control to Computer Simulation of Tracking and Rendezvous Test for Docking of an Adaptive Space Structure" Department of Aerospace Engineering, Nagoya University, Chikusa, Nagoya, Japan, pp. 641-652, presented at the Second Joint US/ Japan Conference on Adaptive Structures Nov. 12-14, 1991.
- Matsuzaki, Y. et al., "Application of Fuzzy Control to Tracking for Docking Operation of an Adaptive Space Structure" Department of Aerospace Engineering, Nagoya university, Chikusa, Nagoya Japan, pp. 792-806 presented at the First Joint US/ Japan Conference on Adaptive Structures Nov. 13-15, 1990.
- Miura, K. et al., "Aerospace Research Status on Adaptive Structures in Japan" Institute of Space and Astronautical Sciences, Yoshinodai, Sagami-hara, Japan, pp. 3-14, presented at the Second Joint US/ Japan Conference on Adaptive Structures Nov. 12-14, 1991.
- Mobrem, M. et al., "Control Design of Space Station Mobile Transporter with Multiple Constraints" Astro Aerospace Corporation, Carpinteria, California pp. 87-116 presented at the First Joint US/ Japan Conference on Adaptive Structures Nov. 13-15, 1990.
- Modi, V.J. et al., "Formulation for a Class of Adaptive Structures with Applications" Department of Mechanical Engineering, The University of British Columbia, Vancouver, British Columbia, Canada, pp. 92-110, presented at the Second Joint US/ Japan Conference on Adaptive Structures Nov. 12-14, 1991.
- Murotsu, Y. et al., "Optical Configuration Control of an Intelligent Truss Structure" Department of Aeronautical Engineering, College of Engineering, University of Osaka Prefecture, Sakai, Osaka Japan, pp. 157-175 presented at the First Joint US/ Japan Conference on Adaptive Structures Nov. 13-15, 1990.
- Murotsu, Y. et al., "Some Approaches to the Optimal Adaptive Geometries of Intelligent Truss Structures" University of Osaka Prefecture, Sakai, Osaka, Japan, pp. 743-771, presented at the First Joint US/ Japan Conference on Adaptive Structures Nov. 13-15, 1990.
- Murotsu, Y. et al., "PD-Impedance Control of Docking Mechanism Composed of Intelligent Adaptive Structure" Department of Aero-

nautical Engineering, College of Engineering, University of Osaka Prefecture, Sakai, Osaka, Japan, pp. 653-669, presented at the Second Joint US/ Japan Conference on Adaptive Structures Nov. 12-14, 1991.

Naccarato, F. et al., "Redundancy Resolution in Variable-Geometry Truss Manipulators Using Reference Shape Curves" Institute for Aerospace Studies, University of Toronto, Downsview, Ontario, Canada, pp. 539-555, presented at the Second Joint US/ Japan Conference on Adaptive Structures Nov. 12-14, 1991.

Natori, M.C. et al., "Application of Adaptive Structure Concepts to Construction of space Systems in Orbit-Concepts and Formulation" Institute of Space and Astronautical Science Sagamihara, Japan pp. 77-91, presented at the Second Joint US/ Japan Conference on Adaptive Structures Nov. 12-14, 1991.

Pai, S.S. et al., "Probabilistic Structural Analysis of Adaptive/Smart/ Intelligent Space Structures" National Aeronautics and Space Administration, Lewis Research Center, Cleveland, Ohio, pp. 419-433, presented at the Second Joint US/ Japan Conference on Adaptive Structures Nov. 12-14, 1991.

Seguchi, Y., "Criteria-Oriented Configuration Control of Adaptive Structure and its Modular Neural Network Representation" Department of Mechanical Engineering, Osaka University Toyonaka, Osaka Japan, pp. 402-421 presented at the First Joint US/ Japan Conference on Adaptive Structures Nov. 13-15, 1990.

Shibuta, S. et al., "Adaptive Control of Space Truss Structures by Piezoelectric Actuator" National Space Development Agency of Japan Tsukuba Space Center, Ibaraki, Japan, pp. 245-262, presented at the Second Joint US/ Japan Conference on Adaptive Structures Nov. 12-14, 1991.

Sirlin, S. W. et al., "Active Structural Control for Damping Augmentation and Compensation of Thermal Distortion" Jet Propulsion Laboratory, California Institute of Technology, Pasadena, California, pp. 434-444, presented at the Second Joint US/ Japan Conference on Adaptive Structures Nov. 12-14, 1991.

Sirlin, S.W. et al., "Sizing of Active Piezoelectric Struts for Vibration Suppression on a Space-Based Interferometer" Jet Propulsion Laboratory California Institute of Technology, Pasadena, California pp. 47-63, 1991.

Stover, D., "Braiding and RTM Succeed in Aircraft Primary Structures", *Advanced Composites* May/June, 1989, 4 pages.

* cited by examiner

Primary Examiner — Samantha Q Lawrence
(74) *Attorney, Agent, or Firm* — Brake Hughes
Bellermann LLP

(57) **CLAIM**

What is claimed is an ornamental design for a beam, as shown and described herein.

DESCRIPTION

This design application is related to following design applications, all of which are incorporated herein by reference in their entireties:

Design application filed on Mar. 6, 2018, entitled, "Beam Design Having Triangular Structures" and assigned U.S. Ser. No. 29/639,492;

Design application filed on Mar. 6, 2018, entitled, "Beam Structure Design Having A Triangular Concave Shape" and assigned U.S. Ser. No. 29/639,493;

Design application filed on Mar. 6, 2018, entitled, "Beam Structure Design Having A Triangular Convex Shape" and assigned U.S. Ser. No. 29/639,494;

Design application filed on Mar. 6, 2018, entitled, "Beam Structure Design Having Interwoven Members" and assigned U.S. Ser. No. 29/639,495; and

Design application filed on Mar. 6, 2018, entitled, "Beam Structure Design Having Flat Surfaces" and assigned U.S. Ser. No. 29/639,496.

FIG. 1 is a partial side view of a first embodiment of a beam; FIG. 2 is a cross-sectional view thereof cut along line 1-1 of FIG. 1;

FIG. 3 is a perspective view of the section of the beam shown in FIG. 1;

FIG. 4 is another perspective view of the section of the beam shown in FIG. 1;

FIG. 5 is zoomed-in view of a portion of the beam shown in FIG. 1, which illustrates claimed portions at intersections of helicals; and

FIG. 6 is zoomed-in view of a portion of the beam shown in FIG. 1, which illustrates claimed portions at intersections of helicals.

FIG. 7 is a partial side view of a second embodiment of a beam;

FIG. 8 is a cross-sectional view thereof cut along line 7-7 of FIG. 7;

FIG. 9 is a perspective view of a section of the beam shown in FIG. 7;

FIG. 10 is another perspective view of a section of the beam shown in FIG. 7;

FIG. 11 is zoomed-in view of a portion of the beam shown in FIG. 7, which illustrates claimed portions at intersections of helicals; and,

FIG. 12 is zoomed-in view of a portion of the beam in FIG. 7, which illustrates claimed portions at intersections of helicals to define a peak.

The broken lines illustrate portions of a beam that form no part of the claimed design. The dot-dash lines illustrate boundaries that form no part of the claimed design.

1 Claim, 11 Drawing Sheets

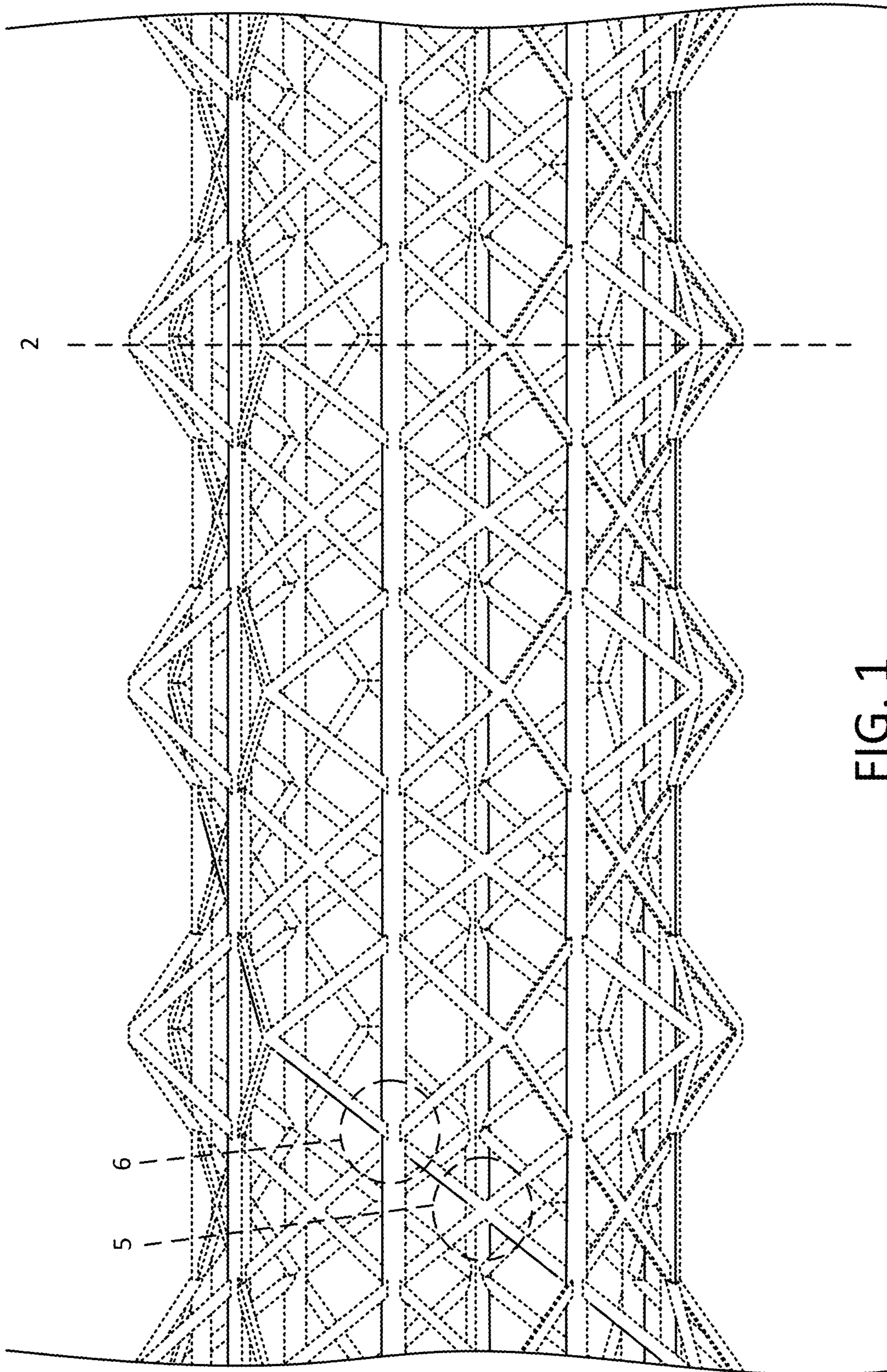

FIG. 1

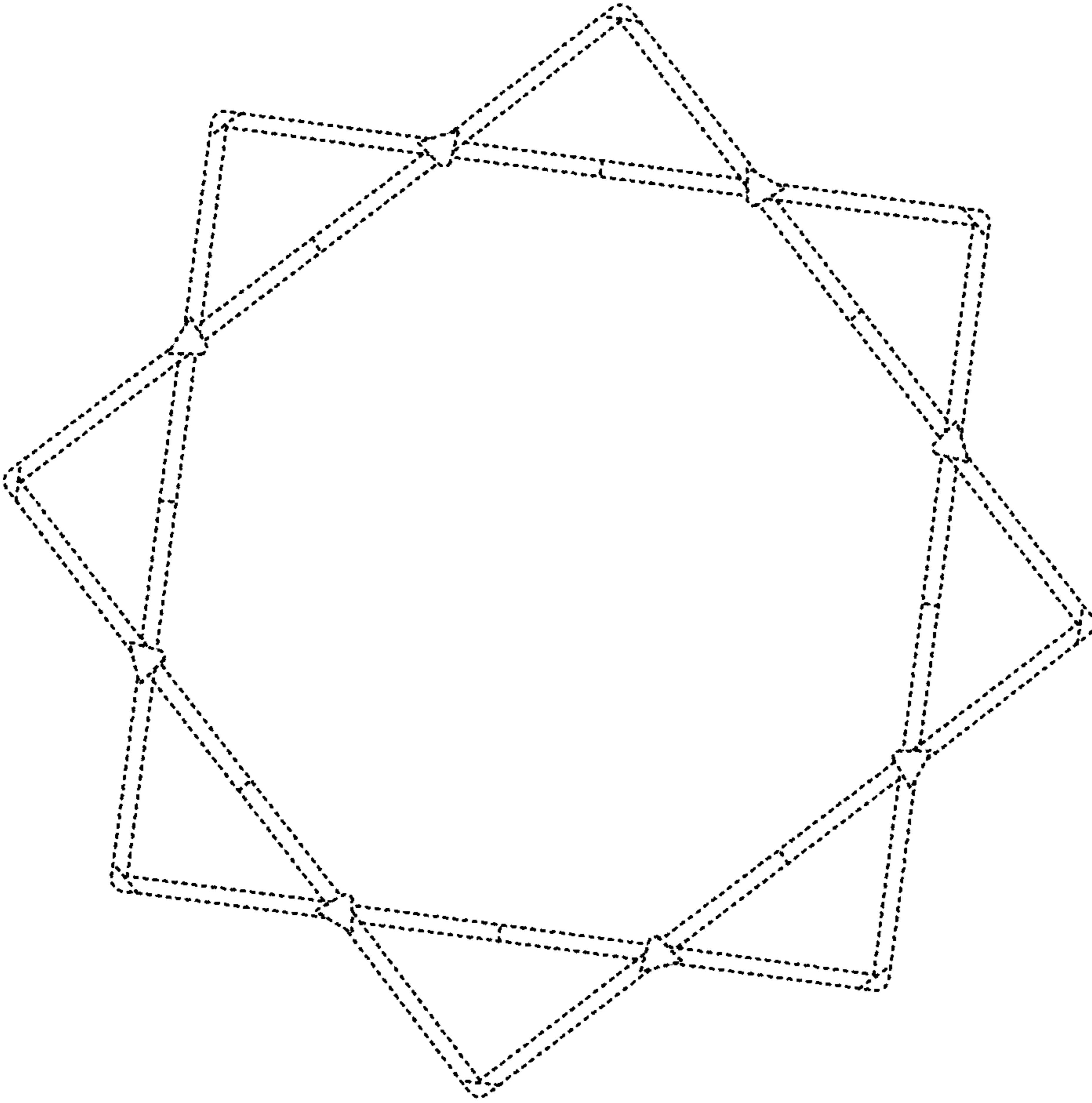

FIG. 2

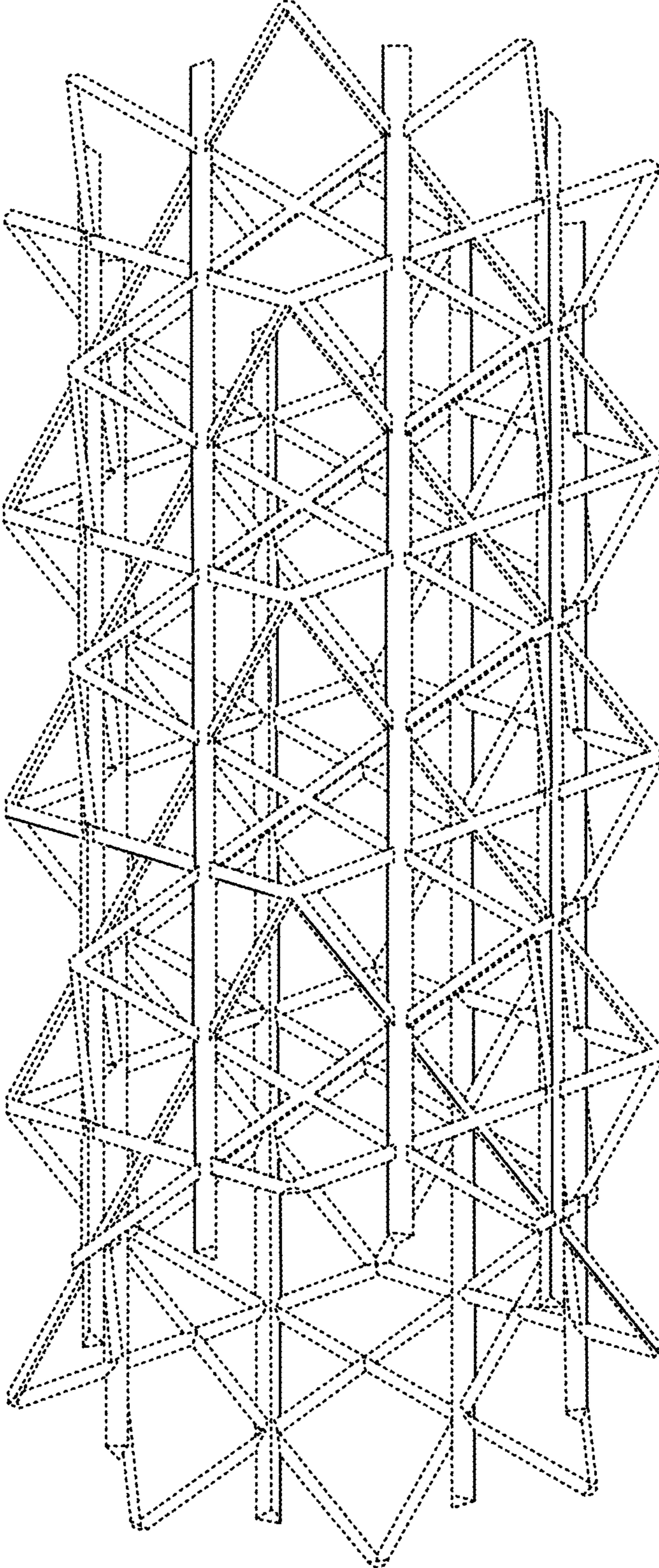

FIG. 3

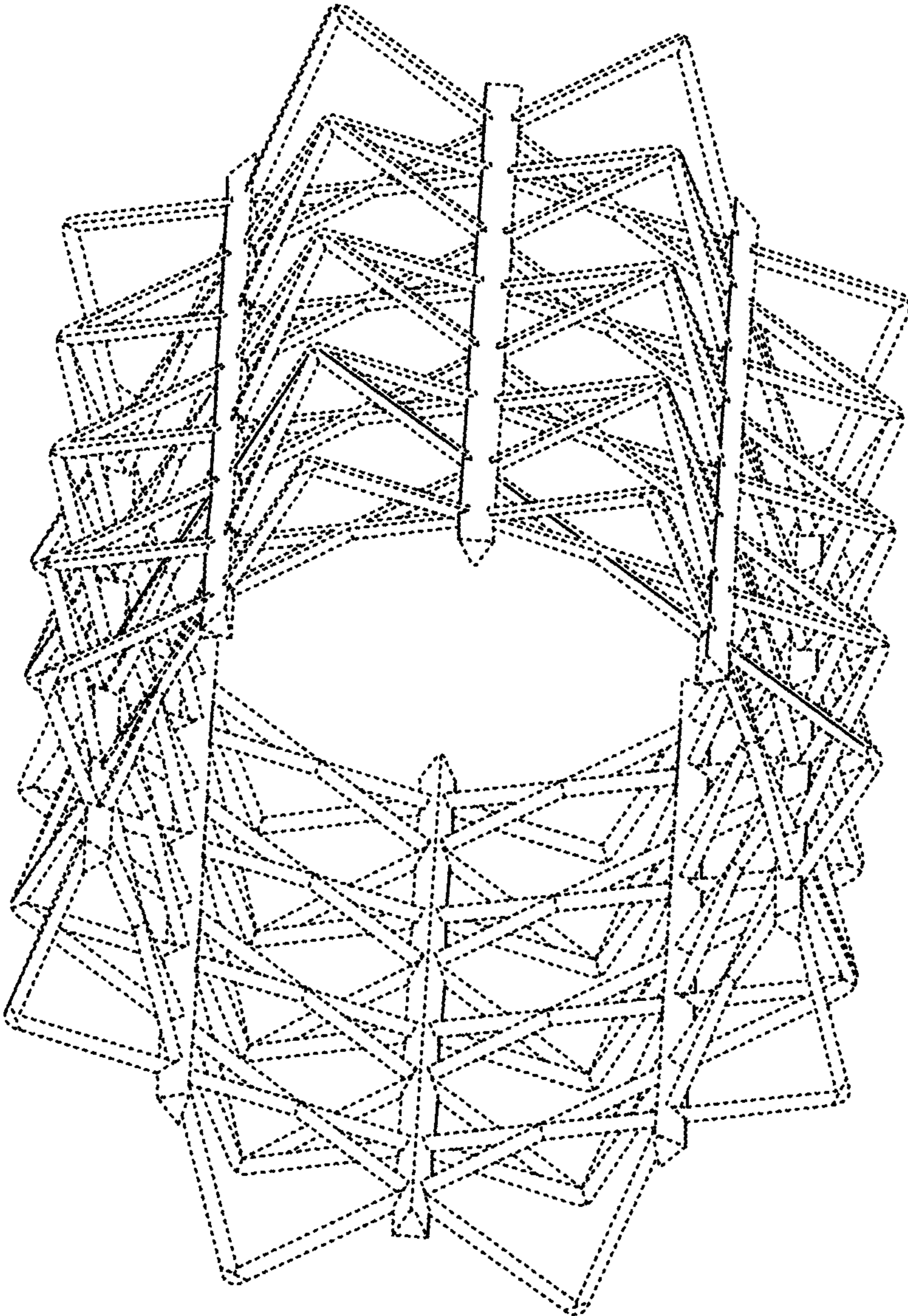

FIG. 4

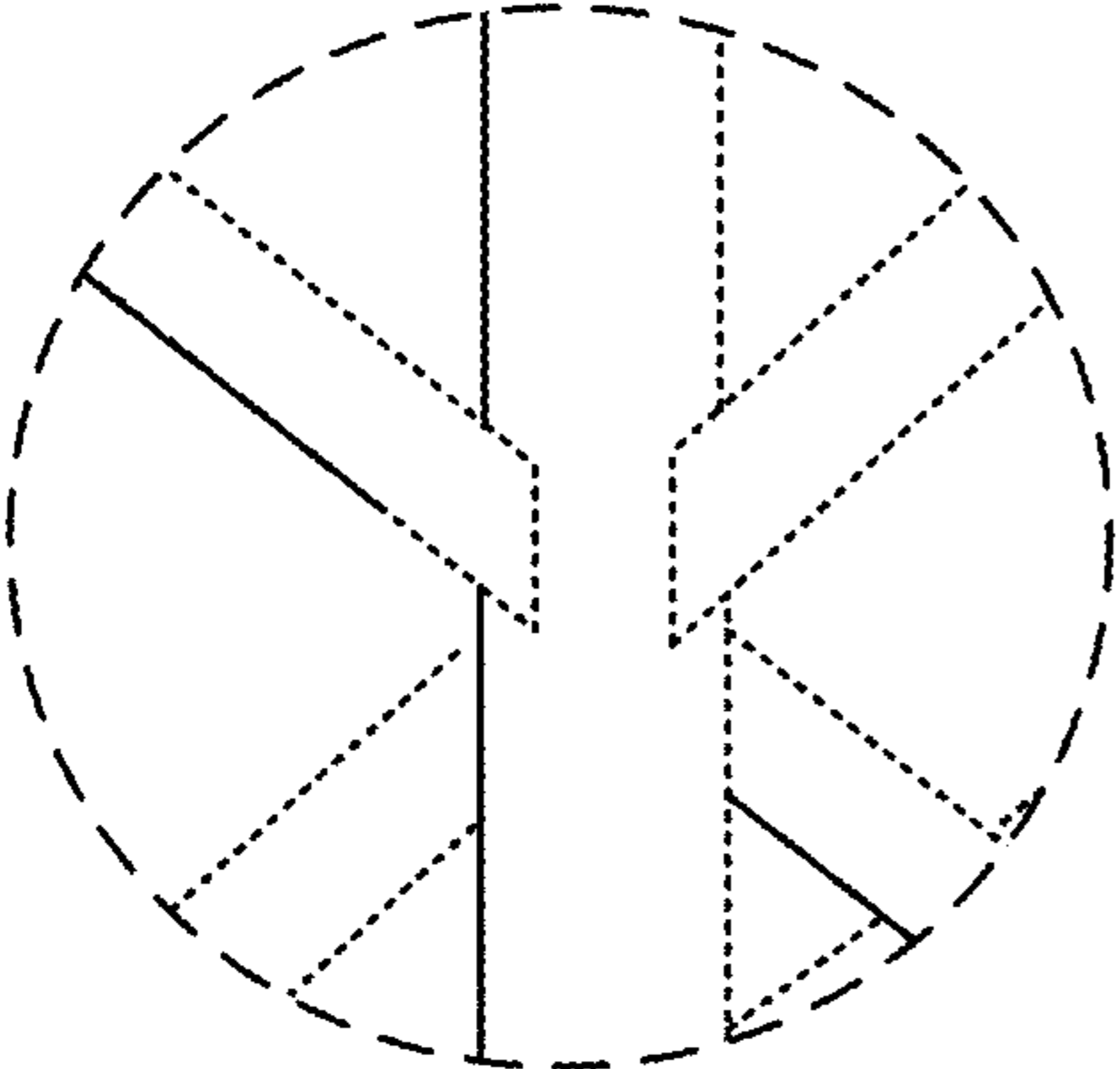

FIG. 6

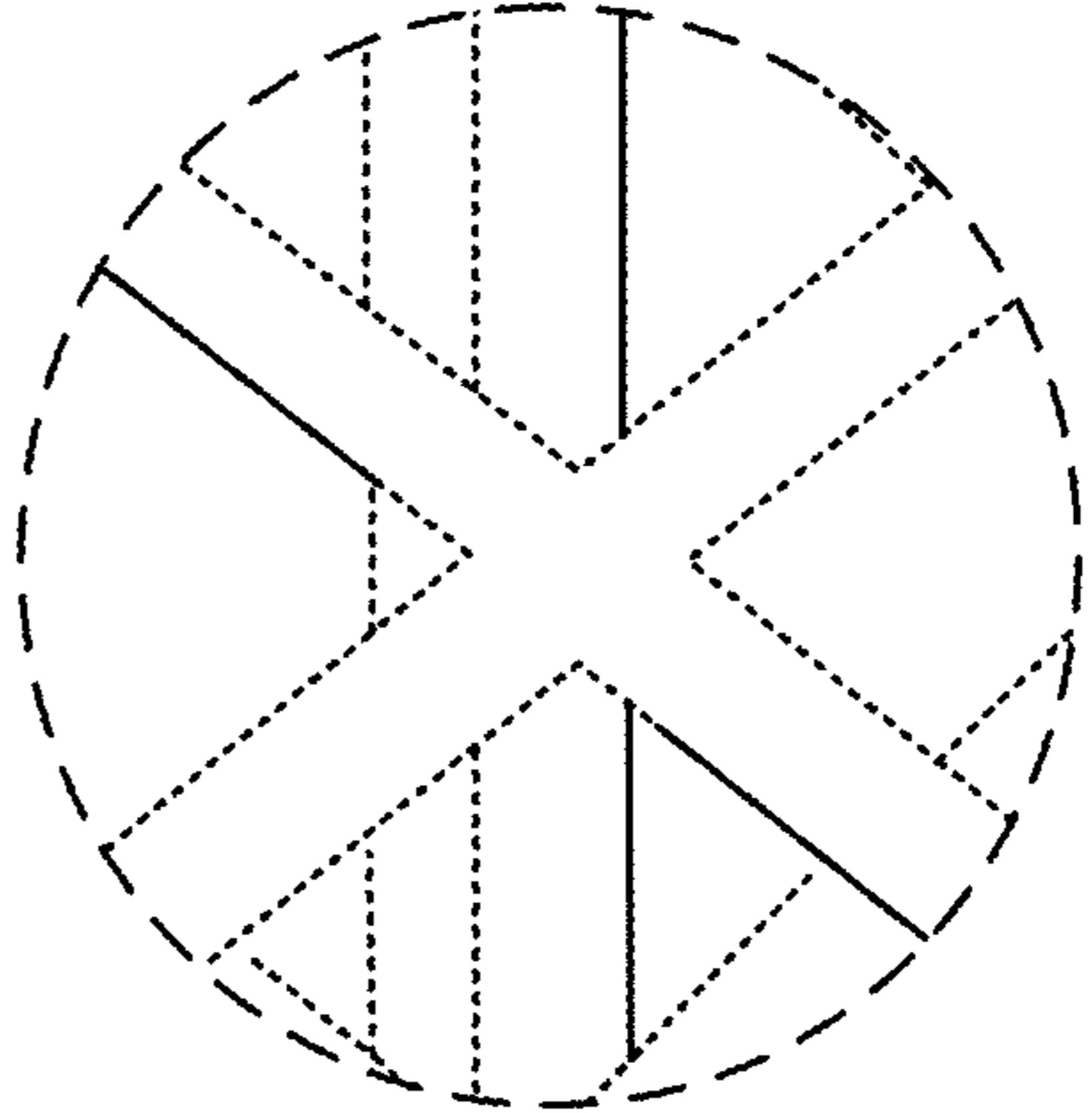

FIG. 5

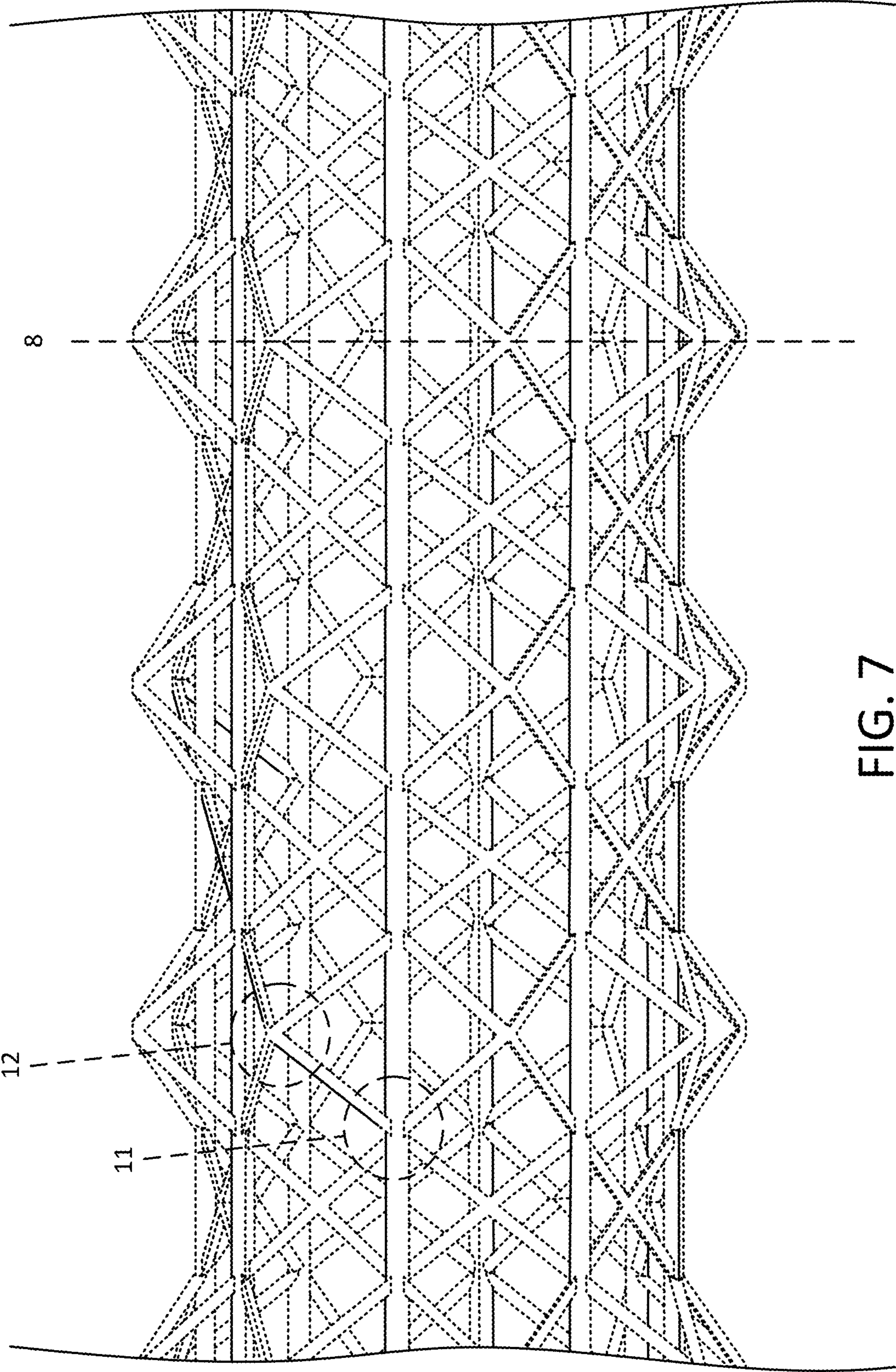

FIG. 7

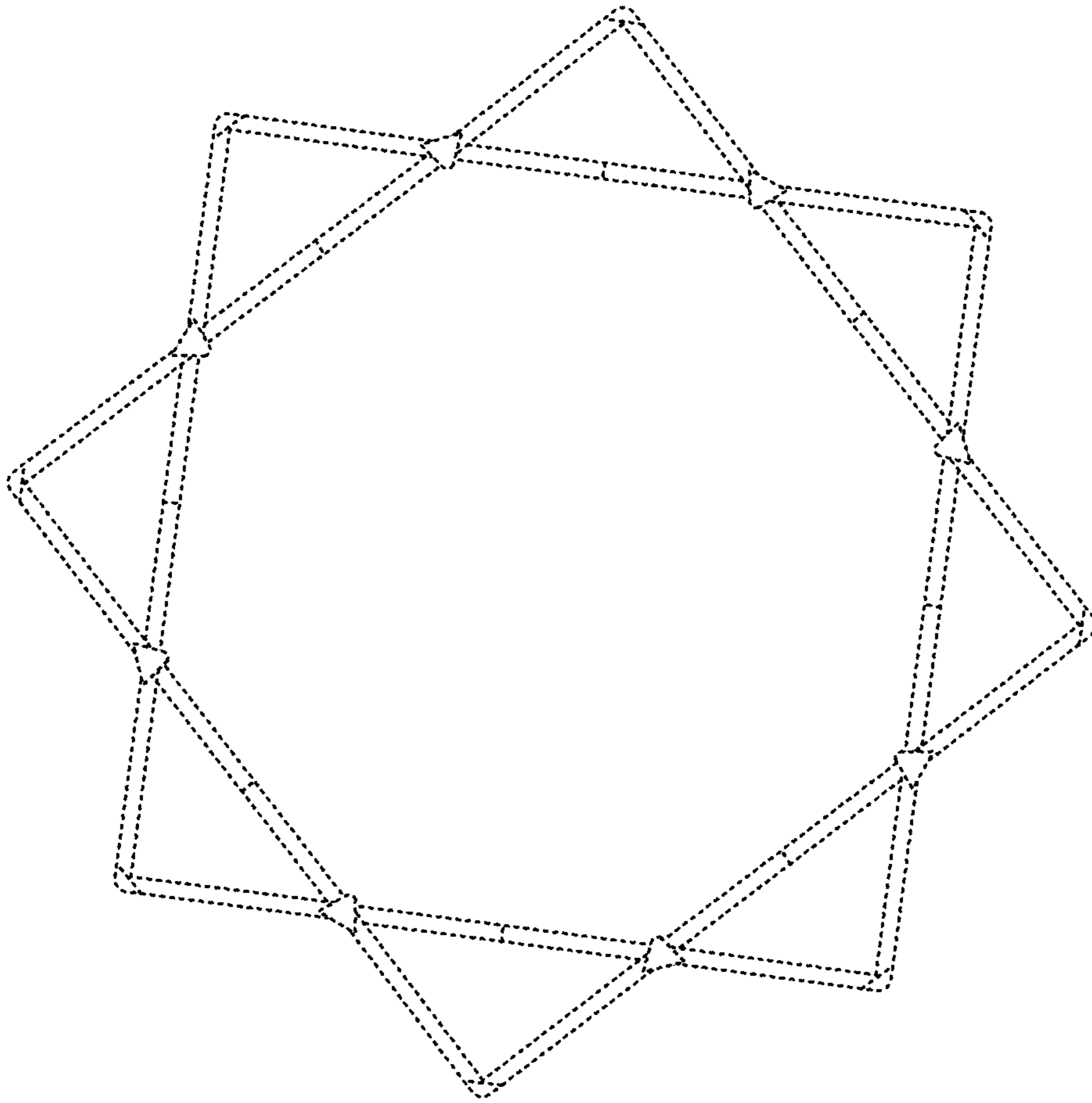

FIG. 8

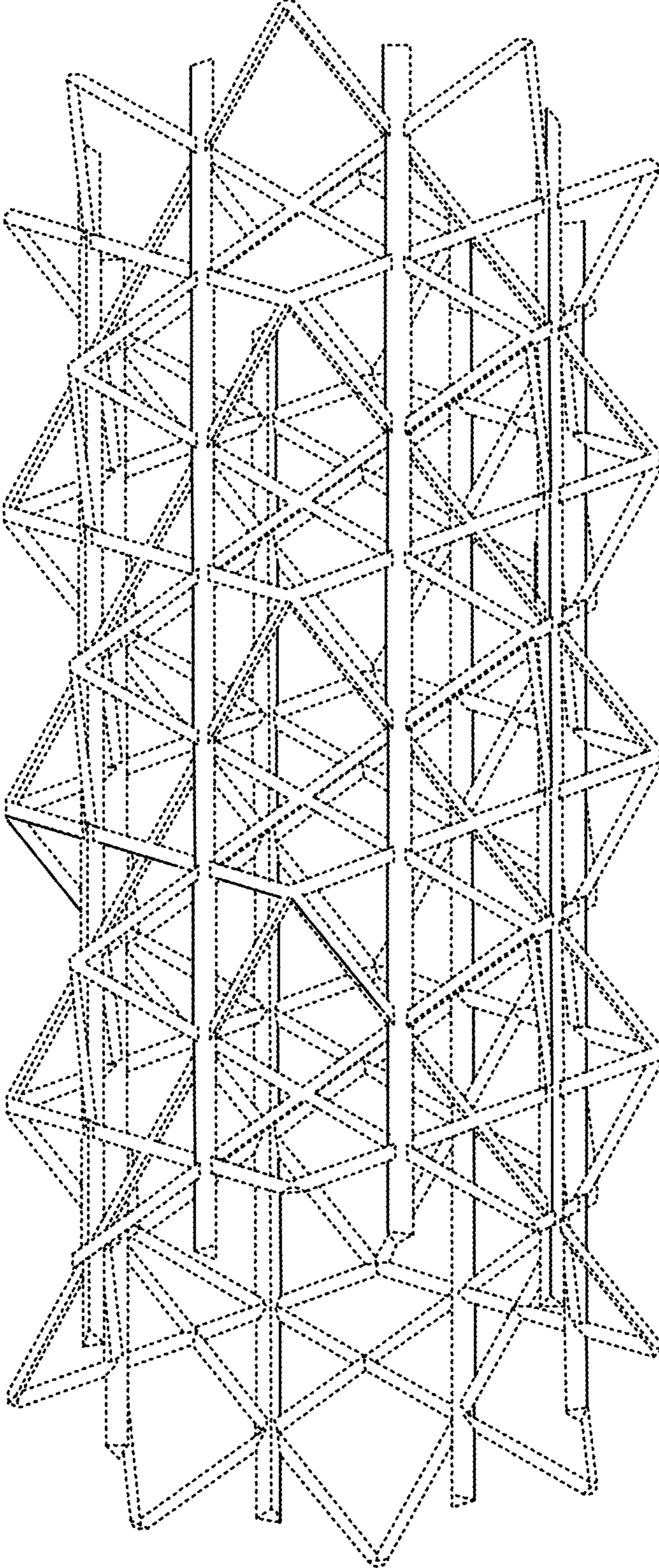

FIG. 9

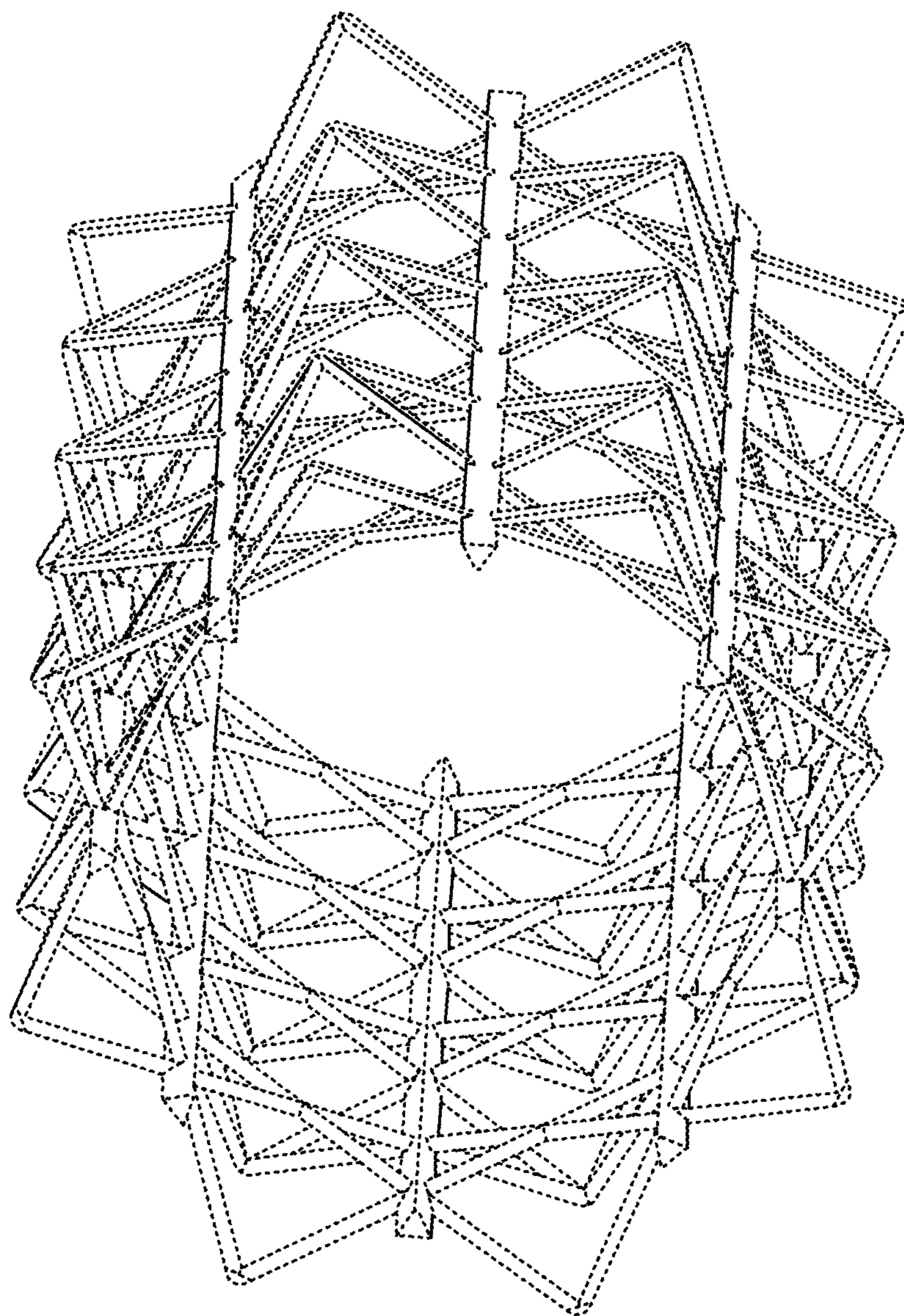

FIG. 10

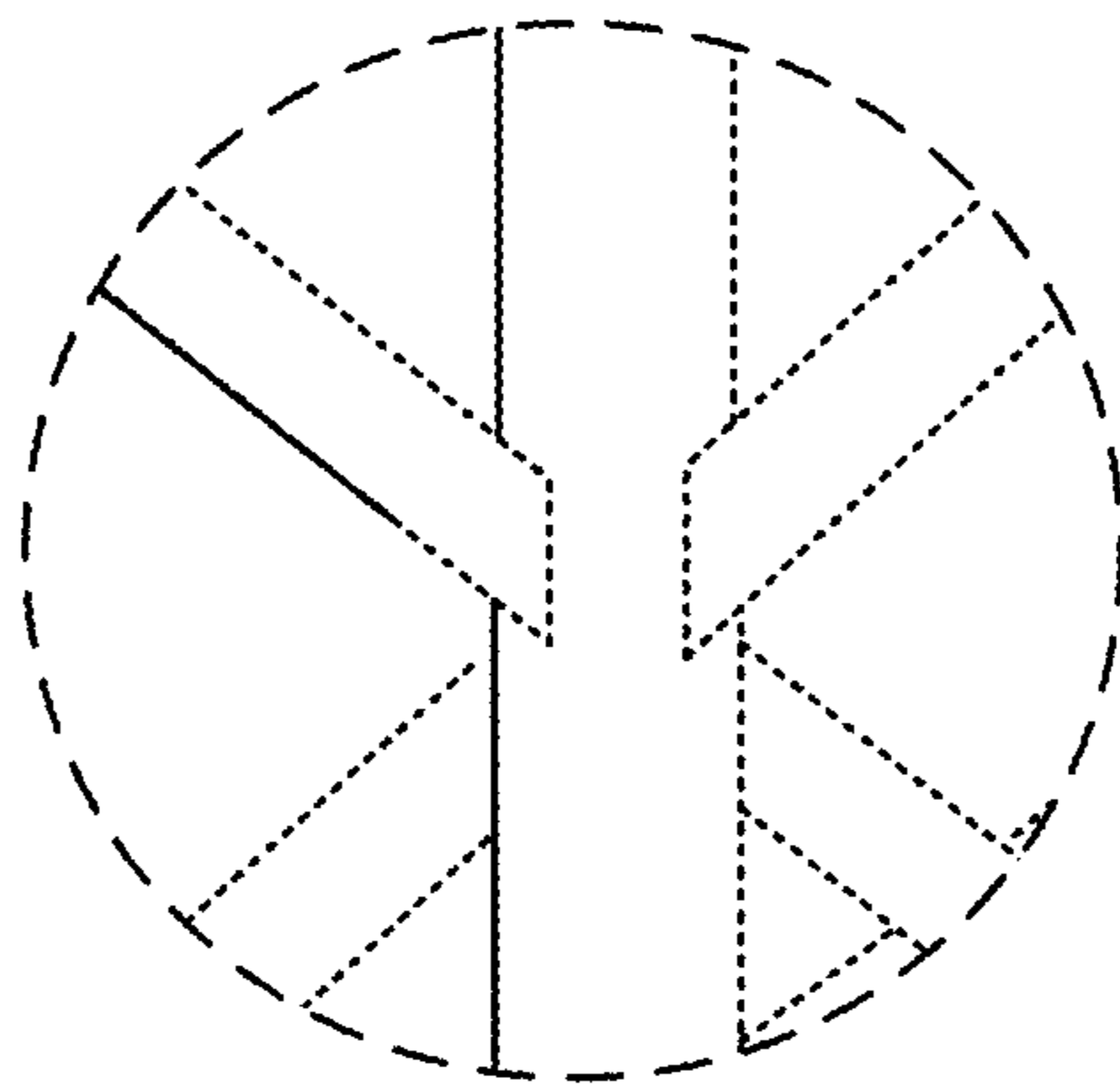

FIG. 11

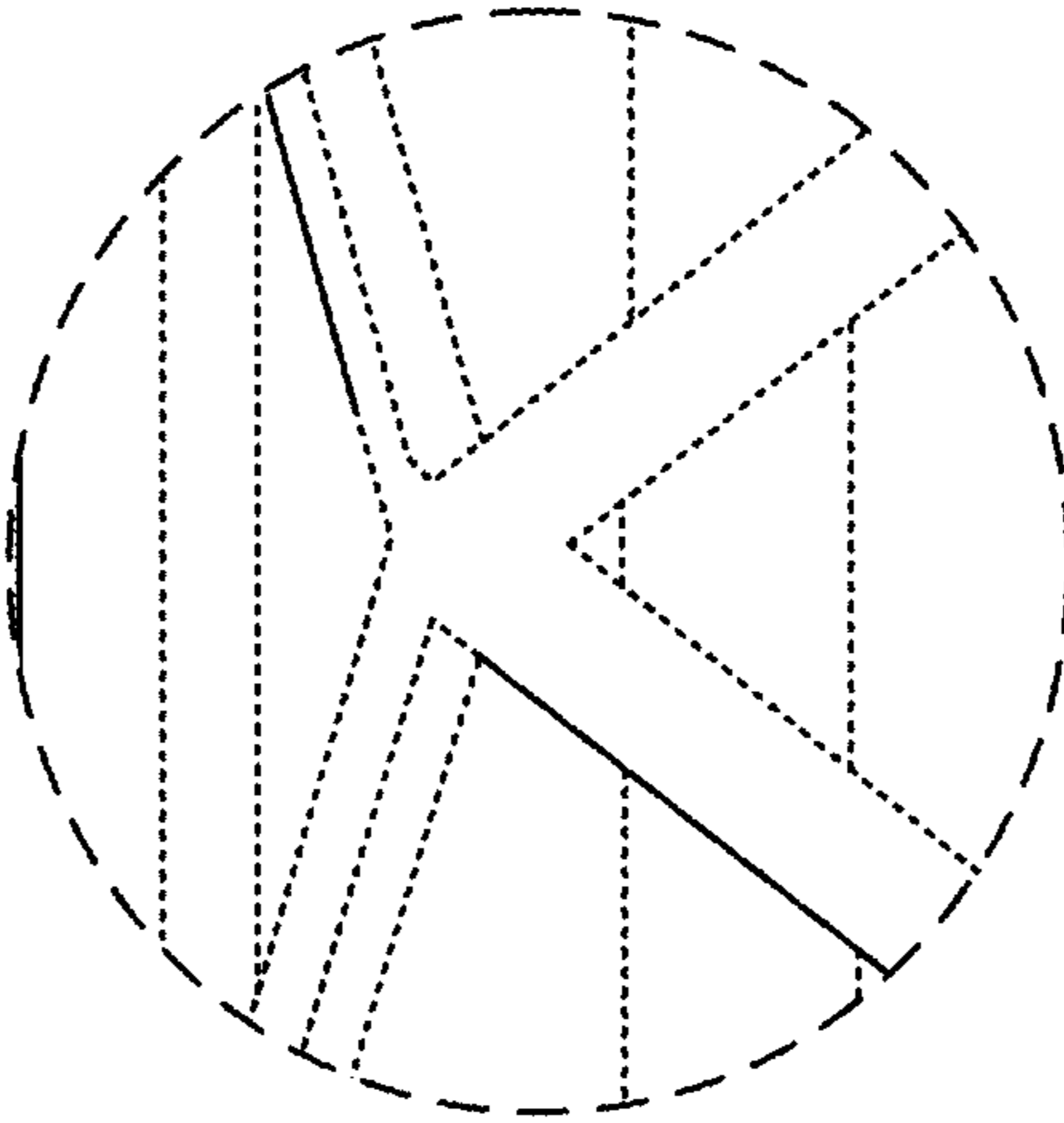

FIG. 12