



US00D896379S

(12) **United States Design Patent** (10) **Patent No.:** **US D896,379 S**
Shelton, IV et al. (45) **Date of Patent:** **** Sep. 15, 2020**

(54) **SURGICAL FASTENER CARTRIDGE**

OTHER PUBLICATIONS

(71) Applicant: **Ethicon LLC**, Guaynabo, PR (US)
(72) Inventors: **Frederick E. Shelton, IV**, Hillsboro, OH (US); **Jason L. Harris**, Lebanon, OH (US); **Gregory J. Bakos**, Mason, OH (US)

Serial Communication Protocol; Michael Lemmon Feb. 1, 2009; <http://www3.nd.edu/~lemmon/courses/ee224/web-manual/web-manual/lab12/node2.html>; Wayback Machine to Apr. 29, 2012.

(Continued)

Primary Examiner — Wan Laymon

(73) Assignee: **Ethicon LLC**, Guaynabo, PR (US)

(57) **CLAIM**

(**) Term: **15 Years**

The ornamental design for a surgical fastener cartridge, as shown and described.

(21) Appl. No.: **29/682,450**

DESCRIPTION

(22) Filed: **Mar. 5, 2019**

Related U.S. Application Data

(63) Continuation of application No. 29/569,259, filed on Jun. 24, 2016, now Pat. No. Des. 847,989.

(51) **LOC (12) Cl.** **24-02**

(52) **U.S. Cl.**
USPC **D24/145**

(58) **Field of Classification Search**
USPC D24/145

(Continued)

(56) **References Cited**

U.S. PATENT DOCUMENTS

66,052 A 6/1867 Smith
662,587 A 11/1900 Blake

(Continued)

FOREIGN PATENT DOCUMENTS

AU 2011218702 B2 6/2013
AU 2012200178 B2 7/2013

(Continued)

The Applicant of the present application owns the following U.S. Design Patent Applications that were filed Jun. 24, 2016, which are each herein incorporated by reference in their respective entireties:

U.S. Design patent application Ser. No. 29/569,218, entitled Surgical Fastener, now U.S. Design Pat. No. D826,405; U.S. Design patent application Ser. No. 29/569,227, entitled Surgical Fastener, now U.S. Design Pat. No. D822,206; and U.S. Design patent application Ser. No. 29/569,264, entitled Surgical Fastener Cartridge.

FIG. 1 is a perspective view of a surgical fastener cartridge. FIG. 2 is a top plan view of the surgical fastener cartridge of FIG. 1.

FIG. 3 is a bottom plan view of the surgical fastener cartridge of FIG. 1.

FIG. 4 is a front elevation view of the surgical fastener cartridge of FIG. 1.

FIG. 5 is an enlarged left elevation view of the surgical fastener cartridge of FIG. 1.

FIG. 6 is an enlarged right elevation view of the surgical fastener cartridge of FIG. 1; and,

FIG. 7 is another enlarged perspective view of the surgical fastener cartridge of FIG. 1.

1 Claim, 5 Drawing Sheets

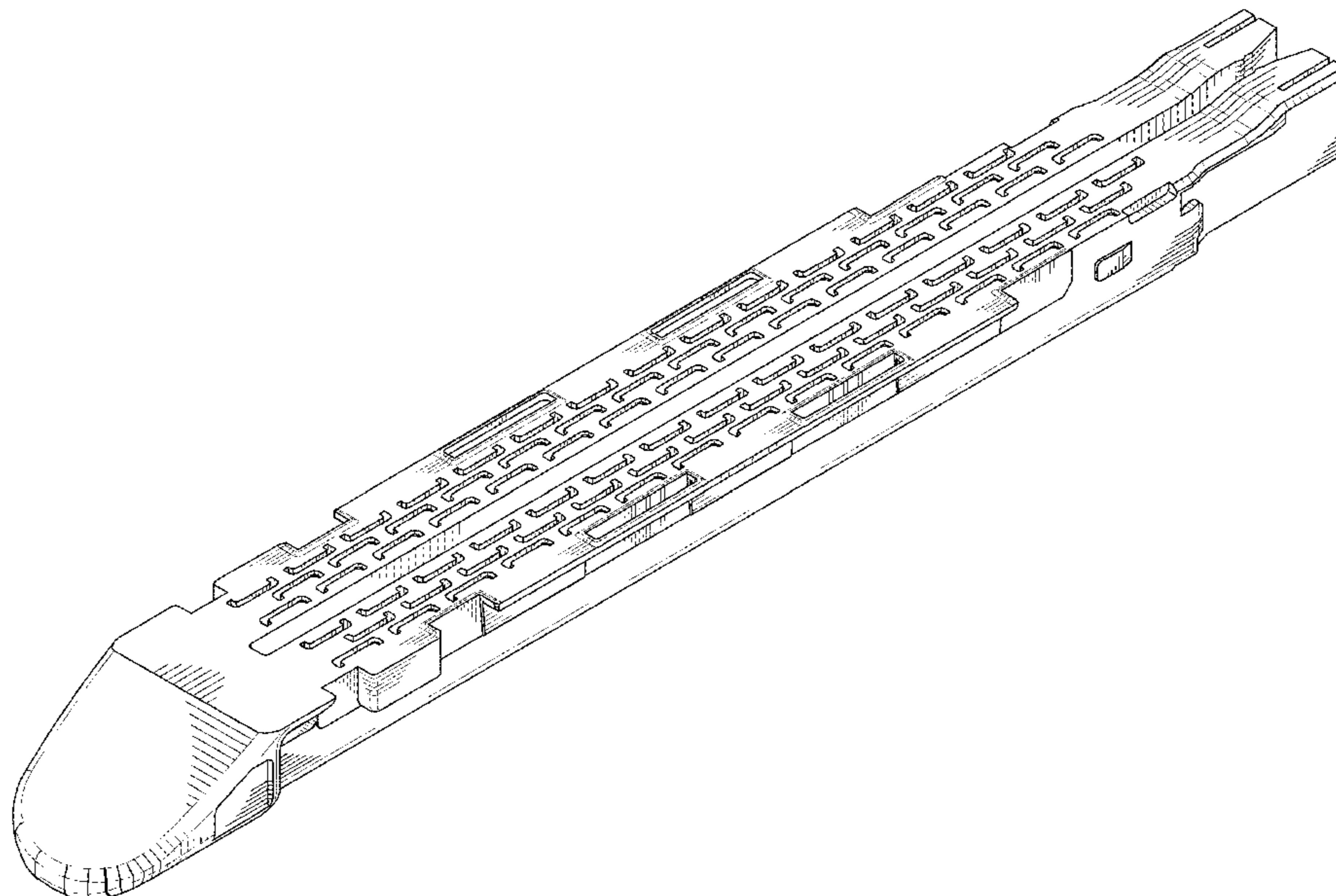

(58)	Field of Classification Search	4,304,236 A	12/1981	Conta et al.
	CPC . A61B 17/105; A61B 17/068; A61B 17/0682;	4,305,539 A	12/1981	Korolkov et al.
	A61B 17/064; A61B 17/072; A61B	4,312,685 A	1/1982	Riedl
	17/07207; A61B 2017/07228; A61B	4,317,451 A	3/1982	Cerwin et al.
	2017/07235; A61B 2017/07242; A61B	4,319,576 A	3/1982	Rothfuss
	2017/07285; A61B 2017/07292	4,321,002 A	3/1982	Froehlich
	See application file for complete search history.	4,328,839 A	5/1982	Lyons et al.
		4,331,277 A	5/1982	Green
		4,340,331 A	7/1982	Savino
(56)	References Cited	4,347,450 A	8/1982	Colligan
	U.S. PATENT DOCUMENTS	4,349,028 A	9/1982	Green
		4,353,371 A	10/1982	Cosman
		4,379,457 A	4/1983	Gravener et al.
		4,380,312 A	4/1983	Landrus
	670,748 A 3/1901 Weddeler	4,382,326 A	5/1983	Rabuse
	951,393 A 3/1910 Hahn	4,383,634 A	5/1983	Green
	1,306,107 A 6/1919 Elliott	4,393,728 A	7/1983	Larson et al.
	1,314,601 A 9/1919 McCaskey	4,396,139 A	8/1983	Hall et al.
	1,677,337 A 7/1928 Grove	4,397,311 A	8/1983	Kanshin et al.
	1,794,907 A 3/1931 Kelly	4,402,445 A	9/1983	Green
	2,037,727 A 4/1936 La Chapelle	4,408,692 A	10/1983	Sigel et al.
	2,132,295 A 10/1938 Hawkins	4,409,057 A	10/1983	Molenda et al.
	2,161,632 A 6/1939 Nattenheimer	4,415,112 A	11/1983	Green
	2,211,117 A 8/1940 Hess	4,416,276 A	11/1983	Newton et al.
	2,214,870 A 9/1940 West	4,428,376 A	1/1984	Mericle
	2,318,379 A 5/1943 Davis et al.	4,429,695 A	2/1984	Green
	2,441,096 A 5/1948 Happe	4,434,796 A	3/1984	Karapetian et al.
	2,475,322 A 7/1949 Horton et al.	4,438,659 A	3/1984	Desplats
	2,526,902 A 10/1950 Rublee	4,442,964 A	4/1984	Becht
	2,578,686 A 12/1951 Fish	4,448,194 A	5/1984	DiGiovanni et al.
	2,674,149 A 4/1954 Benson	4,451,743 A	5/1984	Suzuki et al.
	2,711,461 A 6/1955 Happe	4,454,887 A	6/1984	Kruger
	2,804,848 A 9/1957 O'Farrell et al.	4,467,805 A	8/1984	Fukuda
	2,808,482 A 10/1957 Zanichkowsky et al.	4,473,077 A	9/1984	Noiles et al.
	2,853,074 A 9/1958 Olson	4,475,679 A	10/1984	Fleury, Jr.
	2,886,358 A 5/1959 Munchbach	4,485,816 A	12/1984	Krumme
	2,959,974 A 11/1960 Emrick	4,486,928 A	12/1984	Tucker et al.
	3,032,769 A 5/1962 Palmer	4,488,523 A	12/1984	Shichman
	3,060,972 A 10/1962 Sheldon	4,489,875 A	12/1984	Crawford et al.
	3,075,062 A 1/1963 Iaccarino	4,499,895 A	2/1985	Takayama
	3,078,465 A 2/1963 Bobrov	4,500,024 A	2/1985	DiGiovanni et al.
	3,079,606 A 3/1963 Bobrov et al.	4,505,272 A	3/1985	Utyamyshev et al.
	3,166,072 A 1/1965 Sullivan, Jr.	4,505,273 A	3/1985	Braun et al.
	3,196,869 A 7/1965 Scholl	4,505,414 A	3/1985	Filipi
	3,204,731 A 9/1965 Bent et al.	4,506,671 A	3/1985	Green
	3,266,494 A 8/1966 Brownrigg et al.	4,520,817 A	6/1985	Green
	3,269,630 A 8/1966 Fleischer	4,522,327 A	6/1985	Korthoff et al.
	3,275,211 A 9/1966 Hirsch et al.	4,526,174 A	7/1985	Froehlich
	3,317,103 A 5/1967 Cullen et al.	4,527,724 A	7/1985	Chow et al.
	3,499,591 A 3/1970 Green	4,530,453 A	7/1985	Green
	3,551,987 A 1/1971 Wilkinson	4,531,522 A	7/1985	Bedi et al.
	3,583,393 A 6/1971 Takahashi	4,532,927 A	8/1985	Miksza, Jr.
	3,662,939 A 5/1972 Bryan	4,548,202 A	10/1985	Duncan
	3,717,294 A 2/1973 Green	4,565,109 A	1/1986	Tsay
	3,799,151 A 3/1974 Fukaumi et al.	4,565,189 A	1/1986	Mabuchi
	3,940,844 A 3/1976 Colby et al.	4,566,620 A	1/1986	Green et al.
	RE28,932 E 8/1976 Noiles et al.	4,569,469 A	2/1986	Mongeon et al.
	4,014,244 A 3/1977 Larson	4,571,213 A	2/1986	Ishimoto
	4,060,089 A 11/1977 Noiles	4,573,468 A	3/1986	Conta et al.
	4,106,446 A 8/1978 Yamada et al.	4,573,469 A	3/1986	Golden et al.
	4,108,211 A 8/1978 Tanaka	4,573,622 A	3/1986	Green et al.
	4,111,206 A 9/1978 Vishnevsky et al.	4,576,167 A	3/1986	Noiles
	4,129,059 A 12/1978 Van Eck	4,580,712 A	4/1986	Green
	4,169,990 A 10/1979 Lerdman	4,585,153 A	4/1986	Failla et al.
	4,180,285 A 12/1979 Reneau	4,589,416 A	5/1986	Green
	4,198,734 A 4/1980 Brumlik	4,591,085 A	5/1986	Di Giovanni
	4,198,982 A 4/1980 Fortner et al.	4,597,753 A	7/1986	Turley
	4,207,898 A 6/1980 Becht	4,600,037 A	7/1986	Hatten
	4,213,562 A 7/1980 Garrett et al.	4,604,786 A	8/1986	Howie, Jr.
	4,226,242 A 10/1980 Jarvik	4,605,001 A	8/1986	Rothfuss et al.
	4,241,861 A 12/1980 Fleischer	4,605,004 A	8/1986	Di Giovanni et al.
	4,244,372 A 1/1981 Kapitanov et al.	4,606,343 A	8/1986	Conta et al.
	4,250,436 A 2/1981 Weissman	4,607,638 A	8/1986	Crainich
	4,261,244 A 4/1981 Becht et al.	4,608,981 A	9/1986	Rothfuss et al.
	4,272,002 A 6/1981 Moshofsky	4,610,250 A	9/1986	Green
	4,272,662 A 6/1981 Simpson	4,610,383 A	9/1986	Rothfuss et al.
	4,274,304 A 6/1981 Curtiss	4,612,933 A	9/1986	Brinkerhoff et al.
	4,275,813 A 6/1981 Noiles	D286,180 S	10/1986	Korthoff
	4,289,133 A 9/1981 Rothfuss	D286,441 S	10/1986	Korthoff et al.
	4,296,654 A 10/1981 Mercer			

(56)

References Cited

U.S. PATENT DOCUMENTS

D286,442 S	10/1986	Korthoff et al.	4,930,674 A	6/1990	Barak
4,619,262 A	10/1986	Taylor	4,931,047 A	6/1990	Broadwin et al.
4,619,391 A	10/1986	Sharkany et al.	4,932,960 A	6/1990	Green et al.
4,628,459 A	12/1986	Shinohara et al.	4,938,408 A	7/1990	Bedi et al.
4,629,107 A	12/1986	Fedotov et al.	4,941,623 A	7/1990	Pruitt
4,632,290 A	12/1986	Green et al.	4,944,443 A	7/1990	Oddsens et al.
4,633,874 A	1/1987	Chow et al.	4,951,860 A	8/1990	Peters et al.
4,634,419 A	1/1987	Kreizman et al.	4,955,898 A	9/1990	Matsutani et al.
4,641,076 A	2/1987	Linden	4,955,959 A	9/1990	Tompkins et al.
4,643,731 A	2/1987	Eckenhoff	4,965,709 A	10/1990	Ngo
4,646,722 A	3/1987	Silverstein et al.	4,973,274 A	11/1990	Hirukawa
4,652,820 A	3/1987	Maresca	4,978,049 A	12/1990	Green
4,655,222 A	4/1987	Florez et al.	4,978,333 A	12/1990	Broadwin et al.
4,662,555 A	5/1987	Thornton	4,986,808 A	1/1991	Broadwin et al.
4,663,874 A	5/1987	Sano et al.	4,988,334 A	1/1991	Hornlein et al.
4,664,305 A	5/1987	Blake, III et al.	5,002,543 A	3/1991	Bradshaw et al.
4,665,916 A	5/1987	Green	5,002,553 A	3/1991	Shiber
4,667,674 A	5/1987	Korthoff et al.	5,005,754 A	4/1991	Van Overloop
4,669,647 A	6/1987	Storace	5,009,661 A	4/1991	Michelson
4,671,445 A	6/1987	Barker et al.	5,014,899 A	5/1991	Presty et al.
4,676,245 A	6/1987	Fukuda	5,015,227 A	5/1991	Broadwin et al.
4,684,051 A	8/1987	Akopov et al.	5,018,515 A	5/1991	Gilman
4,693,248 A	9/1987	Failla	5,018,657 A	5/1991	Pedlick et al.
4,700,703 A	10/1987	Resnick et al.	5,024,671 A	6/1991	Tu et al.
4,708,141 A	11/1987	Inoue et al.	5,027,834 A	7/1991	Pruitt
4,709,120 A	11/1987	Pearson	5,031,814 A	7/1991	Tompkins et al.
4,715,520 A	12/1987	Roehr, Jr. et al.	5,035,040 A	7/1991	Kerrigan et al.
4,719,917 A	1/1988	Barrows et al.	5,038,109 A	8/1991	Goble et al.
4,727,308 A	2/1988	Huljak et al.	5,040,715 A	8/1991	Green et al.
4,728,020 A	3/1988	Green et al.	5,042,707 A	8/1991	Taheri
4,728,876 A	3/1988	Mongeon et al.	5,053,047 A	10/1991	Yoon
4,729,260 A	3/1988	Dudden	5,061,269 A	10/1991	Muller
4,730,726 A	3/1988	Holzwarth	5,062,563 A	11/1991	Green et al.
4,741,336 A	5/1988	Failla et al.	5,065,929 A	11/1991	Schulze et al.
4,743,214 A	5/1988	Tai-Cheng	5,071,052 A	12/1991	Rodak et al.
4,747,820 A	5/1988	Hornlein et al.	5,071,430 A	12/1991	de Salis et al.
4,750,902 A	6/1988	Wuchinich et al.	5,074,454 A	12/1991	Peters
4,752,024 A	6/1988	Green et al.	5,079,006 A	1/1992	Urquhart
4,754,909 A	7/1988	Barker et al.	5,080,556 A	1/1992	Carreno
4,767,044 A	8/1988	Green	5,083,695 A	1/1992	Foslien et al.
D297,764 S *	9/1988	Hunt D24/145	5,084,057 A	1/1992	Green et al.
4,773,420 A	9/1988	Green	5,088,979 A	2/1992	Filipi et al.
4,777,780 A	10/1988	Holzwarth	5,088,997 A	2/1992	Delahuerge et al.
4,781,186 A	11/1988	Simpson et al.	5,089,009 A	2/1992	Green
4,787,387 A	11/1988	Burbank, III et al.	5,094,247 A	3/1992	Hernandez et al.
4,790,225 A	12/1988	Moody et al.	5,100,420 A	3/1992	Green et al.
4,802,478 A	2/1989	Powell	5,104,025 A	4/1992	Main et al.
4,805,617 A	2/1989	Bedi et al.	5,104,397 A	4/1992	Vasconcelos et al.
4,805,823 A	2/1989	Rothfuss	5,106,008 A	4/1992	Tompkins et al.
4,809,695 A	3/1989	Gwafhmey et al.	5,108,368 A	4/1992	Hammerslag et al.
4,815,460 A	3/1989	Porat et al.	5,111,987 A	5/1992	Moeinzadeh et al.
4,817,847 A	4/1989	Redtenbacher et al.	5,116,349 A	5/1992	Aranyi
4,819,853 A	4/1989	Green	D327,323 S	6/1992	Hunt
4,821,939 A	4/1989	Green	5,122,156 A	6/1992	Granger et al.
4,827,911 A	5/1989	Broadwin et al.	5,125,876 A	6/1992	Hirota
4,830,855 A	5/1989	Stewart	5,129,570 A	6/1992	Schulze et al.
4,834,720 A	5/1989	Blinkhorn	5,137,198 A	7/1992	Schulze et al.
4,844,068 A	7/1989	Arata et al.	5,139,513 A	8/1992	Nobis et al.
4,848,637 A	7/1989	Pruitt	5,141,144 A	8/1992	Segato
4,865,030 A	9/1989	Polyak	5,142,932 A	8/1992	Foslien et al.
4,869,414 A	9/1989	Green et al.	5,155,941 A	9/1992	Moya et al.
4,869,415 A	9/1989	Fox	5,156,315 A	10/1992	Takahashi et al.
4,873,977 A	10/1989	Avant et al.	5,156,609 A	10/1992	Green et al.
4,874,122 A	10/1989	Froelich et al.	5,156,614 A	10/1992	Green et al.
4,880,015 A	11/1989	Nierman	5,158,567 A	10/1992	Green
4,887,601 A	12/1989	Richards	D330,699 S	11/1992	Gill
4,890,613 A	1/1990	Golden et al.	5,163,598 A	11/1992	Peters et al.
4,892,244 A	1/1990	Fox et al.	5,170,925 A	12/1992	Madden et al.
4,893,622 A	1/1990	Green et al.	5,171,247 A	12/1992	Hughett et al.
4,894,051 A	1/1990	Shiber	5,171,249 A	12/1992	Stefanchik et al.
4,896,678 A	1/1990	Ogawa	5,171,253 A	12/1992	Klieman
4,900,303 A	2/1990	Lemelson	5,188,111 A	2/1993	Yates et al.
4,903,697 A	2/1990	Resnick et al.	5,190,517 A	3/1993	Zieve et al.
4,915,100 A	4/1990	Green	5,190,544 A	3/1993	Chapman et al.
4,930,503 A	6/1990	Pruitt	5,190,560 A	3/1993	Woods et al.
			5,192,288 A	3/1993	Thompson et al.
			5,195,968 A	3/1993	Lundquist et al.
			5,197,648 A	3/1993	Gingold
			5,197,649 A	3/1993	Bessler et al.

(56)

References Cited

U.S. PATENT DOCUMENTS

5,197,966 A	3/1993	Sommerkamp	5,341,724 A	8/1994	Vatel
5,200,280 A	4/1993	Karasa	5,341,810 A	8/1994	Dardel
5,201,746 A	4/1993	Shichman	5,342,381 A	8/1994	Tidemand
5,205,459 A	4/1993	Brinkerhoff et al.	5,342,395 A	8/1994	Jarrett et al.
5,207,697 A	5/1993	Carusillo et al.	5,342,396 A	8/1994	Cook
5,209,747 A	5/1993	Knoepfler	5,344,060 A	9/1994	Gravener et al.
5,211,649 A	5/1993	Kohler et al.	5,344,454 A	9/1994	Clarke et al.
5,211,655 A	5/1993	Hasson	5,346,504 A	9/1994	Ortiz et al.
5,217,457 A	6/1993	Delahuerga et al.	5,348,259 A	9/1994	Blanco et al.
5,217,478 A	6/1993	Rexroth	5,350,388 A	9/1994	Epstein
5,219,111 A	6/1993	Bilotti et al.	5,350,391 A	9/1994	Iacovelli
5,221,036 A	6/1993	Takase	5,350,400 A	9/1994	Esposito et al.
5,221,281 A	6/1993	Klicek	5,352,229 A	10/1994	Goble et al.
5,222,963 A	6/1993	Brinkerhoff et al.	5,352,235 A	10/1994	Koros et al.
5,222,975 A	6/1993	Crainich	5,352,238 A	10/1994	Green et al.
5,222,976 A	6/1993	Yoon	5,354,303 A	10/1994	Spaeth et al.
5,223,675 A	6/1993	Taft	5,356,006 A	10/1994	Alpern et al.
D338,729 S	8/1993	Sprecklemeier et al.	5,358,506 A	10/1994	Green et al.
5,234,447 A	8/1993	Kaster et al.	5,358,510 A	10/1994	Luscombe et al.
5,236,440 A	8/1993	Hlavacek	5,359,231 A	10/1994	Flowers et al.
5,239,981 A	8/1993	Anaplotis	D352,780 S	11/1994	Glaeser et al.
5,240,163 A	8/1993	Stein et al.	5,360,305 A	11/1994	Kerrigan
5,242,457 A	9/1993	Akopov et al.	5,360,428 A	11/1994	Hutchinson, Jr.
5,244,462 A	9/1993	Delahuerga et al.	5,364,001 A	11/1994	Bryan
5,246,156 A	9/1993	Rothfuss et al.	5,364,003 A	11/1994	Williamson, IV
5,246,443 A	9/1993	Mai	5,366,133 A	11/1994	Geiste
5,253,793 A	10/1993	Green et al.	5,366,134 A	11/1994	Green et al.
5,258,009 A	11/1993	Connors	5,366,479 A	11/1994	McGarry et al.
5,258,012 A	11/1993	Luscombe et al.	5,368,015 A	11/1994	Wilk
5,259,366 A	11/1993	Reydel et al.	5,368,592 A	11/1994	Stern et al.
5,260,637 A	11/1993	Pizzi	5,370,645 A	12/1994	Klicek et al.
5,263,629 A	11/1993	Trumbull et al.	5,372,124 A	12/1994	Takayama et al.
5,263,973 A	11/1993	Cook	5,372,596 A	12/1994	Klicek et al.
5,264,218 A	11/1993	Rogozinski	5,372,602 A	12/1994	Burke
5,268,622 A	12/1993	Philipp	5,374,277 A	12/1994	Hassler
5,271,543 A	12/1993	Grant et al.	5,376,095 A	12/1994	Ortiz
5,271,544 A	12/1993	Fox et al.	5,379,933 A	1/1995	Green et al.
RE34,519 E	1/1994	Fox et al.	5,381,649 A	1/1995	Webb
5,275,323 A	1/1994	Schulze et al.	5,381,782 A	1/1995	DeLaRama et al.
5,275,608 A	1/1994	Forman et al.	5,381,943 A	1/1995	Allen et al.
5,279,416 A	1/1994	Malec et al.	5,382,247 A	1/1995	Cimino et al.
5,281,216 A	1/1994	Klicek	5,383,880 A	1/1995	Hooven
5,282,806 A	2/1994	Haber et al.	5,383,881 A	1/1995	Green et al.
5,282,829 A	2/1994	Hermes	5,383,882 A	1/1995	Buess et al.
5,284,128 A	2/1994	Hart	5,383,888 A	1/1995	Zvenyatsky et al.
5,285,945 A	2/1994	Brinkerhoff et al.	5,383,895 A	1/1995	Holmes et al.
5,289,963 A	3/1994	McGarry et al.	5,389,098 A	2/1995	Tsuruta et al.
5,290,271 A	3/1994	Jernberg	5,389,104 A	2/1995	Hahnen et al.
5,292,053 A	3/1994	Bilotti et al.	5,391,180 A	2/1995	Tovey et al.
5,297,714 A	3/1994	Kramer	5,392,978 A	2/1995	Velez et al.
5,303,539 A	4/1994	Neamtu	5,392,979 A	2/1995	Green et al.
5,304,204 A	4/1994	Bregen	5,395,030 A	3/1995	Kuramoto et al.
D347,474 S	5/1994	Olson	5,395,033 A	3/1995	Byrne et al.
5,307,976 A	5/1994	Olson et al.	5,395,034 A	3/1995	Allen et al.
5,308,576 A	5/1994	Green et al.	5,395,312 A	3/1995	Desai
5,309,927 A	5/1994	Welch	5,395,384 A	3/1995	Duthoit et al.
5,312,023 A	5/1994	Green et al.	5,397,046 A	3/1995	Savage et al.
5,312,024 A	5/1994	Grant et al.	5,397,324 A	3/1995	Carroll et al.
5,312,329 A	5/1994	Beaty et al.	5,403,043 A	4/1995	Smet
5,314,424 A	5/1994	Nicholas	5,403,312 A	4/1995	Yates et al.
5,314,445 A	5/1994	Heidmueller nee Degwitz et al.	5,405,072 A	4/1995	Zlock et al.
5,314,466 A	5/1994	Stern et al.	5,405,073 A	4/1995	Porter
5,318,221 A	6/1994	Green et al.	5,405,344 A	4/1995	Williamson et al.
D348,930 S	7/1994	Olson	5,405,360 A	4/1995	Tovey
5,329,923 A	7/1994	Lundquist	5,407,293 A	4/1995	Crainich
5,330,487 A	7/1994	Thornton et al.	5,409,498 A	4/1995	Braddock et al.
5,330,502 A	7/1994	Hassler et al.	D357,981 S	5/1995	Green et al.
5,332,142 A	7/1994	Robinson et al.	5,411,481 A	5/1995	Allen et al.
5,333,422 A	8/1994	Warren et al.	5,411,508 A	5/1995	Bessler et al.
5,333,772 A	8/1994	Rothfuss et al.	5,413,107 A	5/1995	Oakley et al.
5,333,773 A	8/1994	Main et al.	5,413,267 A	5/1995	Solyntjes et al.
5,334,183 A	8/1994	Wuchinich	5,413,268 A	5/1995	Green et al.
5,336,229 A	8/1994	Noda	5,413,272 A	5/1995	Green et al.
5,336,232 A	8/1994	Green et al.	5,413,573 A	5/1995	Koivukangas
5,339,799 A	8/1994	Kami et al.	5,415,334 A	5/1995	Williamson et al.
			5,415,335 A	5/1995	Knodell, Jr.
			5,417,203 A	5/1995	Tovey et al.
			5,417,361 A	5/1995	Williamson, IV
			5,421,829 A	6/1995	Olichney et al.

(56)

References Cited

U.S. PATENT DOCUMENTS

5,422,567 A	6/1995	Matsunaga	5,503,320 A	4/1996	Webster et al.
5,423,471 A	6/1995	Mastri et al.	5,503,635 A	4/1996	Sauer et al.
5,423,809 A	6/1995	Klicek	5,503,638 A	4/1996	Cooper et al.
5,425,745 A	6/1995	Green et al.	5,505,363 A	4/1996	Green et al.
5,431,322 A	7/1995	Green et al.	5,507,425 A	4/1996	Ziglioli
5,431,654 A	7/1995	Nic	5,507,426 A	4/1996	Young et al.
5,431,668 A	7/1995	Burbank, III et al.	5,509,596 A	4/1996	Green et al.
5,433,721 A	7/1995	Hooven et al.	5,509,916 A	4/1996	Taylor
5,437,681 A	8/1995	Meade et al.	5,511,564 A	4/1996	Wilk
5,438,302 A	8/1995	Goble	5,514,129 A	5/1996	Smith
5,439,155 A	8/1995	Viola	5,514,157 A	5/1996	Nicholas et al.
5,439,156 A	8/1995	Grant et al.	5,518,163 A	5/1996	Hooven
5,439,479 A	8/1995	Shichman et al.	5,518,164 A	5/1996	Hooven
5,441,191 A	8/1995	Linden	5,520,678 A	5/1996	Heckele et al.
5,441,193 A	8/1995	Gravener	5,520,700 A	5/1996	Beyar et al.
5,441,483 A	8/1995	Avitall	5,522,817 A	6/1996	Sander et al.
5,441,494 A	8/1995	Ortiz	5,522,831 A	6/1996	Sleister et al.
5,444,113 A	8/1995	Sinclair et al.	5,527,320 A	6/1996	Carruthers et al.
5,445,155 A	8/1995	Sieben	5,529,235 A	6/1996	Boiarski et al.
5,445,304 A	8/1995	Plyley et al.	D372,086 S	7/1996	Grasso et al.
5,445,644 A	8/1995	Pietrafitta et al.	5,531,305 A	7/1996	Roberts et al.
5,447,265 A	9/1995	Vidal et al.	5,531,744 A	7/1996	Nardella et al.
5,447,417 A	9/1995	Kuhl et al.	5,533,521 A	7/1996	Granger
5,447,513 A	9/1995	Davison et al.	5,533,581 A	7/1996	Barth et al.
5,449,355 A	9/1995	Rhum et al.	5,533,661 A	7/1996	Main et al.
5,449,365 A	9/1995	Green et al.	5,535,934 A	7/1996	Boiarski et al.
5,449,370 A	9/1995	Vaitekunas	5,535,935 A	7/1996	Vidal et al.
5,452,836 A	9/1995	Huitema et al.	5,535,937 A	7/1996	Boiarski et al.
5,452,837 A	9/1995	Williamson, IV et al.	5,540,375 A	7/1996	Bolanos et al.
5,454,378 A	10/1995	Palmer et al.	5,541,376 A	7/1996	Ladtchow et al.
5,454,822 A	10/1995	Schob et al.	5,542,594 A	8/1996	McKean et al.
5,454,827 A	10/1995	Aust et al.	5,542,949 A	8/1996	Yoon
5,456,401 A	10/1995	Green et al.	5,543,119 A	8/1996	Sutter et al.
5,458,579 A	10/1995	Chodorow et al.	5,547,117 A	8/1996	Hamblin et al.
5,462,215 A	10/1995	Viola et al.	5,549,621 A	8/1996	Bessler et al.
5,464,013 A	11/1995	Lemelson	5,549,627 A	8/1996	Kieturakis
5,464,144 A	11/1995	Guy et al.	5,549,628 A	8/1996	Cooper et al.
5,464,300 A	11/1995	Crainich	5,549,637 A	8/1996	Crainich
5,465,819 A	11/1995	Weilant et al.	5,551,622 A	9/1996	Yoon
5,465,894 A	11/1995	Clark et al.	5,553,675 A	9/1996	Pitzen et al.
5,465,895 A	11/1995	Knodel et al.	5,553,765 A	9/1996	Knodel et al.
5,465,896 A	11/1995	Allen et al.	5,554,148 A	9/1996	Aebischer et al.
5,466,020 A	11/1995	Page et al.	5,554,169 A	9/1996	Green et al.
5,467,911 A	11/1995	Tsuruta et al.	5,556,416 A	9/1996	Clark et al.
5,468,253 A	11/1995	Bezwada et al.	5,558,665 A	9/1996	Kieturakis
5,470,006 A	11/1995	Rodak	5,558,671 A	9/1996	Yates
5,470,007 A	11/1995	Plyley et al.	5,560,530 A	10/1996	Bolanos et al.
5,470,009 A	11/1995	Rodak	5,560,532 A	10/1996	DeFonzo et al.
5,470,010 A	11/1995	Rothfuss et al.	5,562,239 A	10/1996	Boiarski et al.
5,472,132 A	12/1995	Savage et al.	5,562,241 A	10/1996	Knodel et al.
5,472,442 A	12/1995	Klicek	5,562,682 A	10/1996	Oberlin et al.
5,473,204 A	12/1995	Temple	5,562,690 A	10/1996	Green et al.
5,474,057 A	12/1995	Makower et al.	5,562,701 A	10/1996	Huitema et al.
5,474,223 A	12/1995	Viola et al.	5,562,702 A	10/1996	Huitema et al.
5,474,566 A	12/1995	Alesi et al.	5,564,615 A	10/1996	Bishop et al.
5,476,206 A	12/1995	Green et al.	5,569,161 A	10/1996	Ebling et al.
5,476,479 A	12/1995	Green et al.	5,569,270 A	10/1996	Weng
5,478,003 A	12/1995	Green et al.	5,569,284 A	10/1996	Young et al.
5,478,354 A	12/1995	Tovey et al.	5,571,090 A	11/1996	Sherts
5,480,089 A	1/1996	Blewett	5,571,100 A	11/1996	Goble et al.
5,480,409 A	1/1996	Riza	5,571,116 A	11/1996	Bolanos et al.
5,482,197 A	1/1996	Green et al.	5,571,285 A	11/1996	Chow et al.
5,484,095 A	1/1996	Green et al.	5,573,541 A	11/1996	Green et al.
5,484,398 A	1/1996	Stoddard	5,573,543 A	11/1996	Akopov et al.
5,484,451 A	1/1996	Akopov et al.	5,574,431 A	11/1996	McKeown et al.
5,485,947 A	1/1996	Olson et al.	5,575,054 A	11/1996	Klinzing et al.
5,485,952 A	1/1996	Fontayne	5,575,789 A	11/1996	Bell et al.
5,487,499 A	1/1996	Sorrentino et al.	5,575,799 A	11/1996	Bolanos et al.
5,487,500 A	1/1996	Knodel et al.	5,575,803 A	11/1996	Cooper et al.
5,489,058 A	2/1996	Plyley et al.	5,575,805 A	11/1996	Li
5,489,256 A	2/1996	Adair	5,577,654 A	11/1996	Bishop
5,496,312 A	3/1996	Klicek	5,579,978 A	12/1996	Green et al.
5,496,317 A	3/1996	Goble et al.	5,580,067 A	12/1996	Hamblin et al.
5,497,933 A	3/1996	DeFonzo et al.	5,582,611 A	12/1996	Tsuruta et al.
5,501,654 A	3/1996	Failla et al.	5,582,617 A	12/1996	Klieman et al.
			5,584,425 A	12/1996	Savage et al.
			5,586,711 A	12/1996	Plyley et al.
			5,588,579 A	12/1996	Schnut et al.
			5,588,580 A	12/1996	Paul et al.

(56)

References Cited

U.S. PATENT DOCUMENTS

5,588,581 A	12/1996	Conlon et al.	5,673,840 A	10/1997	Schulze et al.
5,591,170 A	1/1997	Spievack et al.	5,673,841 A	10/1997	Schulze et al.
5,591,187 A	1/1997	Dekel	5,673,842 A	10/1997	Bittner et al.
5,597,107 A	1/1997	Knodel et al.	5,674,286 A	10/1997	D'Alessio et al.
5,599,151 A	2/1997	Daum et al.	5,678,748 A	10/1997	Plyley et al.
5,599,279 A	2/1997	Slotman et al.	5,680,981 A	10/1997	Mililli et al.
5,599,344 A	2/1997	Paterson	5,680,982 A	10/1997	Schulze et al.
5,599,350 A	2/1997	Schulze et al.	5,680,983 A	10/1997	Plyley et al.
5,599,852 A	2/1997	Scopelianos et al.	5,683,349 A	11/1997	Makower et al.
5,601,224 A	2/1997	Bishop et al.	5,685,474 A	11/1997	Seeber
5,603,443 A	2/1997	Clark et al.	5,686,090 A	11/1997	Schilder et al.
5,605,272 A	2/1997	Witt et al.	5,688,270 A	11/1997	Yates et al.
5,605,273 A	2/1997	Hamblin et al.	5,690,269 A	11/1997	Bolanos et al.
5,607,094 A	3/1997	Clark et al.	5,692,668 A	12/1997	Schulze et al.
5,607,095 A	3/1997	Smith et al.	5,693,020 A	12/1997	Rauh
5,607,433 A	3/1997	Polla et al.	5,693,042 A	12/1997	Boiarski et al.
5,607,450 A	3/1997	Zvenyatsky et al.	5,693,051 A	12/1997	Schulze et al.
5,609,285 A	3/1997	Grant et al.	5,695,494 A	12/1997	Becker
5,609,601 A	3/1997	Kolesa et al.	5,695,502 A	12/1997	Pier et al.
5,611,709 A	3/1997	McAnulty	5,695,504 A	12/1997	Gifford, III et al.
5,613,966 A	3/1997	Makower et al.	5,695,524 A	12/1997	Kelley et al.
5,615,820 A	4/1997	Viola	5,697,542 A	12/1997	Knodel et al.
5,618,294 A	4/1997	Aust et al.	5,697,543 A	12/1997	Burdorff
5,618,303 A	4/1997	Marlow et al.	5,697,909 A	12/1997	Eggers et al.
5,618,307 A	4/1997	Donlon et al.	5,697,943 A	12/1997	Sauer et al.
5,619,992 A	4/1997	Guthrie et al.	5,700,270 A	12/1997	Peysner et al.
5,620,289 A	4/1997	Curry	5,702,387 A	12/1997	Arts et al.
5,620,452 A	4/1997	Yoon	5,702,408 A	12/1997	Wales et al.
5,624,398 A	4/1997	Smith et al.	5,702,409 A	12/1997	Rayburn et al.
5,624,452 A	4/1997	Yates	5,704,087 A	1/1998	Strub
5,626,587 A	5/1997	Bishop et al.	5,704,534 A	1/1998	Huitema et al.
5,626,595 A	5/1997	Sklar et al.	5,706,997 A	1/1998	Green et al.
5,628,446 A	5/1997	Geiste et al.	5,706,998 A	1/1998	Plyley et al.
5,628,743 A	5/1997	Cimino	5,707,392 A	1/1998	Kortenbach
5,628,745 A	5/1997	Bek	5,709,334 A	1/1998	Sorrentino et al.
5,630,539 A	5/1997	Plyley et al.	5,709,335 A	1/1998	Heck
5,630,540 A	5/1997	Blewett	5,709,680 A	1/1998	Yates et al.
5,630,541 A	5/1997	Williamson, IV et al.	5,709,706 A	1/1998	Kienzle et al.
5,630,782 A	5/1997	Adair	5,711,472 A	1/1998	Bryan
5,632,432 A	5/1997	Schulze et al.	5,713,128 A	2/1998	Schrenk et al.
5,632,433 A	5/1997	Grant et al.	5,713,505 A	2/1998	Huitema
5,634,584 A	6/1997	Okorochoa et al.	5,713,895 A	2/1998	Lontine et al.
5,636,779 A	6/1997	Palmer	5,713,896 A	2/1998	Nardella
5,636,780 A	6/1997	Green et al.	5,713,920 A	2/1998	Bezwada et al.
5,639,008 A	6/1997	Gallagher et al.	5,715,604 A	2/1998	Lanzoni
D381,077 S	7/1997	Hunt	5,715,987 A	2/1998	Kelley et al.
5,643,291 A	7/1997	Pier et al.	5,715,988 A	2/1998	Palmer
5,645,209 A	7/1997	Green et al.	5,716,366 A	2/1998	Yates
5,647,526 A	7/1997	Green et al.	5,718,359 A	2/1998	Palmer et al.
5,647,869 A	7/1997	Goble et al.	5,718,360 A	2/1998	Green et al.
5,649,937 A	7/1997	Bito et al.	5,718,548 A	2/1998	Cotellessa
5,649,956 A	7/1997	Jensen et al.	5,718,706 A	2/1998	Roger
5,651,491 A	7/1997	Heaton et al.	5,720,744 A	2/1998	Eggleston et al.
5,653,373 A	8/1997	Green et al.	D393,067 S	3/1998	Geary et al.
5,653,374 A	8/1997	Young et al.	5,725,536 A	3/1998	Oberlin et al.
5,653,677 A	8/1997	Okada et al.	5,725,554 A	3/1998	Simon et al.
5,653,721 A	8/1997	Knodel et al.	5,728,110 A	3/1998	Vidal et al.
5,655,698 A	8/1997	Yoon	5,728,121 A	3/1998	Bimbo et al.
5,657,921 A	8/1997	Young et al.	5,730,758 A	3/1998	Allgeyer
5,658,238 A	8/1997	Suzuki et al.	5,732,821 A	3/1998	Stone et al.
5,658,281 A	8/1997	Heard	5,732,871 A	3/1998	Clark et al.
5,658,300 A	8/1997	Bito et al.	5,732,872 A	3/1998	Bolduc et al.
5,658,307 A	8/1997	Exconde	5,733,308 A	3/1998	Daugherty et al.
5,662,258 A	9/1997	Knodel et al.	5,735,445 A	4/1998	Vidal et al.
5,662,260 A	9/1997	Yoon	5,735,848 A	4/1998	Yates et al.
5,662,662 A	9/1997	Bishop et al.	5,735,874 A	4/1998	Measamer et al.
5,665,085 A	9/1997	Nardella	5,738,474 A	4/1998	Blewett
5,665,100 A	9/1997	Yoon	5,738,648 A	4/1998	Lands et al.
5,667,517 A	9/1997	Hooven	5,743,456 A	4/1998	Jones et al.
5,667,526 A	9/1997	Levin	5,747,953 A	5/1998	Philipp
5,667,527 A	9/1997	Cook	5,749,889 A	5/1998	Bacich et al.
5,669,544 A	9/1997	Schulze et al.	5,749,893 A	5/1998	Vidal et al.
5,669,904 A	9/1997	Platt, Jr. et al.	5,752,644 A	5/1998	Bolanos et al.
5,669,907 A	9/1997	Platt, Jr. et al.	5,752,965 A	5/1998	Francis et al.
5,669,918 A	9/1997	Balazs et al.	5,755,717 A	5/1998	Yates et al.
			5,758,814 A	6/1998	Gallagher et al.
			5,762,255 A	6/1998	Chrisman et al.
			5,762,256 A	6/1998	Mastri et al.
			5,766,188 A	6/1998	Igaki

(56)

References Cited

U.S. PATENT DOCUMENTS

5,766,205 A	6/1998	Zvenyatsky et al.	5,860,975 A	1/1999	Goble et al.
5,769,892 A	6/1998	Kingwell	5,865,361 A	2/1999	Milliman et al.
5,772,379 A	6/1998	Evensen	5,868,760 A	2/1999	McGuckin, Jr.
5,772,578 A	6/1998	Heimberger et al.	5,868,790 A	2/1999	Vincent et al.
5,772,659 A	6/1998	Becker et al.	5,871,135 A	2/1999	Williamson, IV et al.
5,776,130 A	7/1998	Buyse et al.	5,873,885 A	2/1999	Weidenbenner
5,778,939 A	7/1998	Hok-Yin	5,876,401 A	3/1999	Schulze et al.
5,779,130 A	7/1998	Alesi et al.	5,878,193 A	3/1999	Wang et al.
5,779,131 A	7/1998	Knodel et al.	5,878,937 A	3/1999	Green et al.
5,779,132 A	7/1998	Knodel et al.	5,878,938 A	3/1999	Bittner et al.
5,782,396 A	7/1998	Mastri et al.	5,891,160 A	4/1999	Williamson, IV et al.
5,782,397 A	7/1998	Koukline	5,893,506 A	4/1999	Powell
5,782,748 A	7/1998	Palmer et al.	5,893,835 A	4/1999	Witt et al.
5,782,749 A	7/1998	Riza	5,893,863 A	4/1999	Yoon
5,782,859 A	7/1998	Nicholas et al.	5,893,878 A	4/1999	Pierce
5,784,934 A	7/1998	Izumisawa	5,894,979 A	4/1999	Powell
5,785,232 A	7/1998	Vidal et al.	5,897,552 A	4/1999	Edwards et al.
5,785,647 A	7/1998	Tompkins et al.	5,897,562 A	4/1999	Bolanos et al.
5,787,897 A	8/1998	Kieturakis	5,899,914 A	5/1999	Zirps et al.
5,792,135 A	8/1998	Madhani et al.	5,901,895 A	5/1999	Heaton et al.
5,792,165 A	8/1998	Klieman et al.	5,902,312 A	5/1999	Frater et al.
5,794,834 A	8/1998	Hamblin et al.	5,904,647 A	5/1999	Ouchi
5,796,188 A	8/1998	Bays	5,904,693 A	5/1999	Dicesare et al.
5,797,536 A	8/1998	Smith et al.	5,904,702 A	5/1999	Ek et al.
5,797,537 A	8/1998	Oberlin et al.	5,906,625 A	5/1999	Bito et al.
5,797,538 A	8/1998	Heaton et al.	5,908,402 A	6/1999	Blythe
5,797,906 A	8/1998	Rhum et al.	5,908,427 A	6/1999	McKean et al.
5,797,958 A	8/1998	Yoon	5,911,353 A	6/1999	Bolanos et al.
5,797,959 A	8/1998	Castro et al.	5,915,616 A	6/1999	Viola et al.
5,799,857 A	9/1998	Robertson et al.	5,916,225 A	6/1999	Kugel
5,800,379 A	9/1998	Edwards	5,918,791 A	7/1999	Sorrentino et al.
5,800,423 A	9/1998	Jensen	5,919,198 A	7/1999	Graves, Jr. et al.
5,806,676 A	9/1998	Wasgien	5,919,202 A	7/1999	Yoon
5,807,376 A	9/1998	Viola et al.	5,921,956 A	7/1999	Grinberg et al.
5,807,378 A	9/1998	Jensen et al.	5,928,256 A	7/1999	Riza
5,807,393 A	9/1998	Williamson, IV et al.	5,931,847 A	8/1999	Bittner et al.
5,809,441 A	9/1998	McKee	5,931,853 A	8/1999	McEwen et al.
5,810,721 A	9/1998	Mueller et al.	5,937,951 A	8/1999	Izuchukwu et al.
5,810,811 A	9/1998	Yates et al.	5,938,667 A	8/1999	Peysen et al.
5,810,846 A	9/1998	Virnich et al.	5,941,442 A	8/1999	Geiste et al.
5,810,855 A	9/1998	Rayburn et al.	5,941,890 A	8/1999	Voegele et al.
5,813,813 A	9/1998	Daum et al.	5,944,172 A	8/1999	Hannula
5,814,055 A	9/1998	Knodel et al.	5,944,715 A	8/1999	Goble et al.
5,814,057 A	9/1998	Oi et al.	5,947,984 A	9/1999	Whipple
5,816,471 A	10/1998	Plyley et al.	5,947,996 A	9/1999	Logeman
5,817,084 A	10/1998	Jensen	5,948,030 A	9/1999	Miller et al.
5,817,091 A	10/1998	Nardella et al.	5,951,516 A	9/1999	Bunyan
5,817,093 A	10/1998	Williamson, IV et al.	5,951,552 A	9/1999	Long et al.
5,817,109 A	10/1998	McGarry et al.	5,951,574 A	9/1999	Stefanchik et al.
5,817,119 A	10/1998	Klieman et al.	5,951,581 A	9/1999	Saadat et al.
5,820,009 A	10/1998	Melling et al.	5,954,259 A	9/1999	Viola et al.
5,823,066 A	10/1998	Huitema et al.	5,964,394 A	10/1999	Robertson
5,826,776 A	10/1998	Schulze et al.	5,964,774 A	10/1999	McKean et al.
5,827,271 A	10/1998	Buyse et al.	5,971,916 A	10/1999	Koren
5,827,298 A	10/1998	Hart et al.	5,973,221 A	10/1999	Collyer et al.
5,829,662 A	11/1998	Allen et al.	D416,089 S	11/1999	Barton et al.
5,830,598 A	11/1998	Patterson	5,984,949 A	11/1999	Levin
5,833,690 A	11/1998	Yates et al.	5,988,479 A	11/1999	Palmer
5,833,695 A	11/1998	Yoon	5,997,528 A	12/1999	Bisch et al.
5,833,696 A	11/1998	Whitfield et al.	5,997,552 A	12/1999	Person et al.
5,836,503 A	11/1998	Ehrenfels et al.	6,003,517 A	12/1999	Sheffield et al.
5,836,960 A	11/1998	Kolesa et al.	6,004,319 A	12/1999	Goble et al.
5,839,639 A	11/1998	Sauer et al.	6,004,335 A	12/1999	Vaitekunas et al.
5,843,021 A	12/1998	Edwards et al.	6,010,054 A	1/2000	Johnson et al.
5,843,096 A	12/1998	Igaki et al.	6,010,513 A	1/2000	Tormala et al.
5,843,097 A	12/1998	Mayenberger et al.	6,012,494 A	1/2000	Balazs
5,843,122 A	12/1998	Riza	6,013,076 A	1/2000	Goble et al.
5,843,132 A	12/1998	Ilvento	6,015,406 A	1/2000	Goble et al.
5,843,169 A	12/1998	Taheri	6,015,417 A	1/2000	Reynolds, Jr.
5,846,254 A	12/1998	Schulze et al.	6,017,322 A	1/2000	Snoke et al.
5,849,011 A	12/1998	Jones et al.	6,017,354 A	1/2000	Culp et al.
5,849,023 A	12/1998	Mericle	6,017,356 A	1/2000	Frederick et al.
5,855,311 A	1/1999	Hamblin et al.	6,022,352 A	2/2000	Vandewalle
5,855,583 A	1/1999	Wang et al.	6,024,741 A	2/2000	Williamson, IV et al.
5,860,581 A	1/1999	Robertson et al.	6,024,748 A	2/2000	Manzo et al.
			6,027,501 A	2/2000	Goble et al.
			6,032,849 A	3/2000	Mastri et al.
			6,033,378 A	3/2000	Lundquist et al.
			6,033,399 A	3/2000	Gines

(56)

References Cited

U.S. PATENT DOCUMENTS

6,033,427	A	3/2000	Lee	6,181,105	B1	1/2001	Cutolo et al.
6,037,724	A	3/2000	Buss et al.	6,182,673	B1	2/2001	Kindermann et al.
6,039,733	A	3/2000	Buyse et al.	6,187,003	B1	2/2001	Buyse et al.
6,039,734	A	3/2000	Goble	6,190,386	B1	2/2001	Rydell
6,042,601	A	3/2000	Smith	6,193,129	B1	2/2001	Bittner et al.
6,045,560	A	4/2000	McKean et al.	6,197,042	B1	3/2001	Ginn et al.
6,047,861	A	4/2000	Vidal et al.	6,200,330	B1	3/2001	Benderev et al.
6,050,172	A	4/2000	Corves et al.	6,202,914	B1	3/2001	Geiste et al.
6,050,472	A	4/2000	Shibata	6,206,897	B1	3/2001	Jamiolkowski et al.
6,050,990	A	4/2000	Tankovich et al.	6,206,904	B1	3/2001	Ouchi
6,050,996	A	4/2000	Schmaltz et al.	6,210,403	B1	4/2001	Klicek
6,053,390	A	4/2000	Green et al.	6,213,999	B1	4/2001	Platt, Jr. et al.
6,053,922	A	4/2000	Krause et al.	6,214,028	B1	4/2001	Yoon et al.
RE36,720	E	5/2000	Green et al.	6,220,368	B1	4/2001	Ark et al.
6,056,735	A	5/2000	Okada et al.	6,223,100	B1	4/2001	Green
6,056,746	A	5/2000	Goble et al.	6,223,835	B1	5/2001	Habedank et al.
6,062,360	A	5/2000	Shields	6,224,617	B1	5/2001	Saadat et al.
6,063,097	A	5/2000	Oi et al.	6,228,081	B1	5/2001	Goble
6,063,098	A	5/2000	Houser et al.	6,228,083	B1	5/2001	Lands et al.
6,065,919	A	5/2000	Peck	6,228,084	B1	5/2001	Kirwan, Jr.
6,066,132	A	5/2000	Chen et al.	6,231,565	B1	5/2001	Tovey et al.
6,068,627	A	5/2000	Orszulak et al.	6,234,178	B1	5/2001	Goble et al.
6,071,233	A	6/2000	Ishikawa et al.	6,241,139	B1	6/2001	Milliman et al.
6,074,386	A	6/2000	Goble et al.	6,241,140	B1	6/2001	Adams et al.
6,074,401	A	6/2000	Gardiner et al.	6,241,723	B1	6/2001	Heim et al.
6,077,286	A	6/2000	Cuschieri et al.	6,245,084	B1	6/2001	Mark et al.
6,079,606	A	6/2000	Milliman et al.	6,248,117	B1	6/2001	Blatter
6,080,181	A	6/2000	Jensen et al.	6,249,076	B1	6/2001	Madden et al.
6,082,577	A	7/2000	Coates et al.	6,250,532	B1	6/2001	Green et al.
6,083,191	A	7/2000	Rose	6,258,107	B1	7/2001	Balazs et al.
6,083,234	A	7/2000	Nicholas et al.	6,261,286	B1	7/2001	Goble et al.
6,083,242	A	7/2000	Cook	6,264,086	B1	7/2001	McGuckin, Jr.
6,086,544	A	7/2000	Hibner et al.	6,264,087	B1	7/2001	Whitman
6,086,600	A	7/2000	Kortenbach	6,270,508	B1	8/2001	Klieman et al.
6,090,106	A	7/2000	Goble et al.	6,273,876	B1	8/2001	Klima et al.
6,093,186	A	7/2000	Goble	6,273,897	B1	8/2001	Dalessandro et al.
6,099,537	A	8/2000	Sugai et al.	6,277,114	B1	8/2001	Bullivant et al.
6,099,551	A	8/2000	Gabbay	6,293,942	B1	9/2001	Goble et al.
6,102,271	A	8/2000	Longo et al.	6,296,640	B1	10/2001	Wampler et al.
6,109,500	A	8/2000	Alli et al.	6,302,311	B1	10/2001	Adams et al.
6,117,148	A	9/2000	Ravo et al.	6,305,891	B1	10/2001	Burlingame
6,117,158	A	9/2000	Measamer et al.	6,306,134	B1	10/2001	Goble et al.
6,119,913	A	9/2000	Adams et al.	6,306,149	B1	10/2001	Meade
6,120,433	A	9/2000	Mizuno et al.	6,309,403	B1	10/2001	Minor et al.
6,123,241	A	9/2000	Walter et al.	6,315,184	B1	11/2001	Whitman
H001904	H	10/2000	Yates et al.	6,320,123	B1	11/2001	Reimers
6,126,058	A	10/2000	Adams et al.	6,322,494	B1	11/2001	Bullivant et al.
6,126,359	A	10/2000	Dittrich et al.	6,324,339	B1	11/2001	Hudson et al.
6,126,670	A	10/2000	Walker et al.	6,325,799	B1	12/2001	Goble
6,131,789	A	10/2000	Schulze et al.	6,325,810	B1	12/2001	Hamilton et al.
6,131,790	A	10/2000	Piraka	6,330,965	B1	12/2001	Milliman et al.
6,132,368	A	10/2000	Cooper	6,331,181	B1	12/2001	Tierney et al.
6,139,546	A	10/2000	Koenig et al.	6,331,761	B1	12/2001	Kumar et al.
6,149,660	A	11/2000	Laufer et al.	6,333,029	B1	12/2001	Vyakarnam et al.
6,152,935	A	11/2000	Kammerer et al.	6,334,860	B1	1/2002	Dorn
6,153,292	A	11/2000	Bell et al.	6,334,861	B1	1/2002	Chandler et al.
6,155,473	A	12/2000	Tompkins et al.	6,336,926	B1	1/2002	Goble
6,156,056	A	12/2000	Kearns et al.	6,338,737	B1	1/2002	Toledano
6,159,146	A	12/2000	El Gazayerli	6,343,731	B1	2/2002	Adams et al.
6,159,200	A	12/2000	Verdura et al.	6,346,077	B1	2/2002	Taylor et al.
6,159,224	A	12/2000	Yoon	6,348,061	B1	2/2002	Whitman
6,162,208	A	12/2000	Hipps	6,352,503	B1	3/2002	Matsui et al.
6,165,175	A	12/2000	Wampler et al.	6,352,532	B1	3/2002	Kramer et al.
6,165,184	A	12/2000	Verdura et al.	6,355,699	B1	3/2002	Vyakarnam et al.
6,165,188	A	12/2000	Saadat et al.	6,356,072	B1	3/2002	Chass
6,168,605	B1	1/2001	Measamer et al.	6,358,224	B1	3/2002	Tims et al.
6,171,305	B1	1/2001	Sherman	6,364,877	B1	4/2002	Goble et al.
6,171,316	B1	1/2001	Kovac et al.	6,364,888	B1	4/2002	Niemeyer et al.
6,171,330	B1	1/2001	Benchetrit	6,370,981	B2	4/2002	Watarai
6,174,308	B1	1/2001	Goble et al.	6,373,152	B1	4/2002	Wang et al.
6,174,309	B1	1/2001	Wrublewski et al.	6,383,201	B1	5/2002	Dong
6,179,194	B1	1/2001	Morton	6,383,958	B1	5/2002	Swanson et al.
6,179,195	B1	1/2001	Adams et al.	6,387,113	B1	5/2002	Hawkins et al.
6,179,776	B1	1/2001	Adams et al.	6,387,114	B2	5/2002	Adams
6,179,849	B1	1/2001	Yencho et al.	6,391,038	B2	5/2002	Vargas et al.
				6,398,781	B1	6/2002	Goble et al.
				6,398,797	B2	6/2002	Bombard et al.
				6,402,766	B2	6/2002	Bowman et al.
				6,406,440	B1	6/2002	Stefanchik

(56)

References Cited

U.S. PATENT DOCUMENTS

6,406,472 B1	6/2002	Jensen	6,589,164 B1	7/2003	Flaherty
6,409,724 B1	6/2002	Penny et al.	6,592,538 B1	7/2003	Hotchkiss et al.
H002037 H	7/2002	Yates et al.	6,592,597 B2	7/2003	Grant et al.
6,413,274 B1	7/2002	Pedros	6,596,296 B1	7/2003	Nelson et al.
6,416,486 B1	7/2002	Wampler	6,596,304 B1	7/2003	Bayon et al.
6,416,509 B1	7/2002	Goble et al.	6,596,432 B2	7/2003	Kawakami et al.
6,419,695 B1	7/2002	Gabbay	D478,665 S	8/2003	Isaacs et al.
6,423,079 B1	7/2002	Blake, III	D478,986 S	8/2003	Johnston et al.
RE37,814 E	8/2002	Allgeyer	6,601,749 B2	8/2003	Sullivan et al.
6,428,070 B1	8/2002	Takanashi et al.	6,602,252 B2	8/2003	Mollenauer
6,429,611 B1	8/2002	Li	6,602,262 B2	8/2003	Griego et al.
6,436,097 B1	8/2002	Nardella	6,605,078 B2	8/2003	Adams
6,436,107 B1	8/2002	Wang et al.	6,605,669 B2	8/2003	Awokola et al.
6,436,110 B2	8/2002	Bowman et al.	6,607,475 B2	8/2003	Doyle et al.
6,436,122 B1	8/2002	Frank et al.	6,613,069 B2	9/2003	Boyd et al.
6,439,439 B1	8/2002	Rickard et al.	6,616,686 B2	9/2003	Coleman et al.
6,439,446 B1	8/2002	Perry et al.	6,619,529 B2	9/2003	Green et al.
6,440,146 B2	8/2002	Nicholas et al.	6,620,166 B1	9/2003	Wenstrom, Jr. et al.
6,443,973 B1	9/2002	Whitman	6,626,834 B2	9/2003	Dunne et al.
6,447,518 B1	9/2002	Krause et al.	6,629,630 B2	10/2003	Adams
6,447,864 B2	9/2002	Johnson et al.	6,629,974 B2	10/2003	Penny et al.
6,450,391 B1	9/2002	Kayan et al.	6,629,988 B2	10/2003	Weadock
6,450,989 B2	9/2002	Dubrul et al.	6,636,412 B2	10/2003	Smith
6,454,781 B1	9/2002	Witt et al.	6,638,108 B2	10/2003	Tachi
6,468,275 B1	10/2002	Wampler et al.	6,638,285 B2	10/2003	Gabbay
6,471,106 B1	10/2002	Reining	6,638,297 B1	10/2003	Huitema
6,478,210 B2	11/2002	Adams et al.	RE38,335 E	11/2003	Aust et al.
6,482,200 B2	11/2002	Shippert	6,641,528 B2	11/2003	Torii
6,485,490 B2	11/2002	Wampler et al.	6,644,532 B2	11/2003	Green et al.
6,485,503 B2	11/2002	Jacobs et al.	6,645,201 B1	11/2003	Utley et al.
6,485,667 B1	11/2002	Tan	6,646,307 B1	11/2003	Yu et al.
6,488,196 B1	12/2002	Fenton, Jr.	6,648,816 B2	11/2003	Irion et al.
6,488,197 B1	12/2002	Whitman	6,652,595 B1	11/2003	Nicolo
6,491,201 B1	12/2002	Whitman	D484,243 S	12/2003	Ryan et al.
6,491,690 B1	12/2002	Goble et al.	D484,595 S	12/2003	Ryan et al.
6,491,701 B2	12/2002	Tierney et al.	D484,596 S	12/2003	Ryan et al.
6,492,785 B1	12/2002	Kasten et al.	6,656,177 B2	12/2003	Truckai et al.
6,494,896 B1	12/2002	D'Alessio et al.	6,656,193 B2	12/2003	Grant et al.
6,500,176 B1	12/2002	Truckai et al.	6,663,623 B1	12/2003	Oyama et al.
6,500,194 B2	12/2002	Benderev et al.	6,663,641 B1	12/2003	Kovac et al.
6,503,257 B2	1/2003	Grant et al.	6,666,854 B1	12/2003	Lange
6,503,259 B2	1/2003	Huxel et al.	6,666,875 B1	12/2003	Sakurai et al.
6,505,768 B2	1/2003	Whitman	6,667,825 B2	12/2003	Lu et al.
6,510,854 B2	1/2003	Goble	6,669,073 B2	12/2003	Milliman et al.
6,511,468 B1	1/2003	Cragg et al.	6,670,806 B2	12/2003	Wendt et al.
6,512,360 B1	1/2003	Goto et al.	6,671,185 B2	12/2003	Duval
6,517,528 B1	2/2003	Pantages et al.	D484,977 S	1/2004	Ryan et al.
6,517,535 B2	2/2003	Edwards	6,676,660 B2	1/2004	Wampler et al.
6,517,565 B1	2/2003	Whitman et al.	6,679,269 B2	1/2004	Swanson
6,517,566 B1	2/2003	Hovland et al.	6,679,410 B2	1/2004	Wursch et al.
6,522,101 B2	2/2003	Malackowski	6,681,978 B2	1/2004	Geiste et al.
6,527,782 B2	3/2003	Hogg et al.	6,681,979 B2	1/2004	Whitman
6,527,785 B2	3/2003	Sancoff et al.	6,682,527 B2	1/2004	Strul
6,533,157 B1	3/2003	Whitman	6,682,528 B2	1/2004	Frazier et al.
6,533,784 B2	3/2003	Truckai et al.	6,685,727 B2	2/2004	Fisher et al.
6,535,764 B2	3/2003	Imran et al.	6,689,153 B1	2/2004	Skiba
6,543,456 B1	4/2003	Freeman	6,692,507 B2	2/2004	Pugsley et al.
6,545,384 B1	4/2003	Pelrine et al.	6,695,198 B2	2/2004	Adams et al.
6,547,786 B1	4/2003	Goble	6,695,199 B2	2/2004	Whitman
6,550,546 B2	4/2003	Thurler et al.	6,698,643 B2	3/2004	Whitman
6,551,333 B2	4/2003	Kuhns et al.	6,699,235 B2	3/2004	Wallace et al.
6,554,861 B2	4/2003	Knox et al.	6,704,210 B1	3/2004	Myers
6,555,770 B2	4/2003	Kawase	6,705,503 B1	3/2004	Pedicini et al.
6,558,378 B2	5/2003	Sherman et al.	6,709,445 B2	3/2004	Boebel et al.
6,558,379 B1	5/2003	Batchelor et al.	6,712,773 B1	3/2004	Viola
6,565,560 B1	5/2003	Goble et al.	6,716,223 B2	4/2004	Leopold et al.
6,569,085 B2	5/2003	Kortenbach et al.	6,716,232 B1	4/2004	Vidal et al.
6,569,171 B2	5/2003	DeGuillebon et al.	6,716,233 B1	4/2004	Whitman
6,578,751 B2	6/2003	Hartwick	6,722,552 B2	4/2004	Fenton, Jr.
6,582,427 B1	6/2003	Goble et al.	6,723,087 B2	4/2004	O'Neill et al.
6,582,441 B1	6/2003	He et al.	6,723,091 B2	4/2004	Goble et al.
6,583,533 B2	6/2003	Pelrine et al.	6,723,109 B2	4/2004	Solingen
6,585,144 B2	7/2003	Adams et al.	6,726,697 B2	4/2004	Nicholas et al.
6,588,643 B2	7/2003	Bolduc et al.	6,729,119 B2	5/2004	Schnipke et al.
6,589,118 B1	7/2003	Soma et al.	6,736,825 B2	5/2004	Blatter et al.
			6,736,854 B2	5/2004	Vadurro et al.
			6,740,030 B2	5/2004	Martone et al.
			6,747,121 B2	6/2004	Gogolewski
			6,749,560 B1	6/2004	Konstorum et al.

(56)

References Cited

U.S. PATENT DOCUMENTS

6,752,768 B2	6/2004	Burdorff et al.	6,878,106 B1	4/2005	Herrmann
6,752,816 B2	6/2004	Culp et al.	6,889,116 B2	5/2005	Jinno
6,755,195 B1	6/2004	Lemke et al.	6,893,435 B2	5/2005	Goble
6,755,338 B2	6/2004	Hahnen et al.	6,899,538 B2	5/2005	Matoba
6,758,846 B2	7/2004	Goble et al.	6,905,057 B2	6/2005	Swayze et al.
6,761,685 B2	7/2004	Adams et al.	6,905,497 B2	6/2005	Truckai et al.
6,762,339 B1	7/2004	Klun et al.	6,908,472 B2	6/2005	Wiener et al.
6,767,352 B2	7/2004	Field et al.	6,911,033 B2	6/2005	de Guillebon et al.
6,767,356 B2	7/2004	Kanner et al.	6,913,579 B2	7/2005	Truckai et al.
6,769,590 B2	8/2004	Vresh et al.	6,913,608 B2	7/2005	Liddicoat et al.
6,769,594 B2	8/2004	Orban, III	6,913,613 B2	7/2005	Schwarz et al.
6,770,027 B2	8/2004	Banik et al.	6,921,397 B2	7/2005	Corcoran et al.
6,770,072 B1	8/2004	Truckai et al.	6,921,412 B1	7/2005	Black et al.
6,773,409 B2	8/2004	Truckai et al.	6,923,093 B2	8/2005	Ullah
6,773,437 B2	8/2004	Ogilvie et al.	6,923,803 B2	8/2005	Goble
6,773,438 B1	8/2004	Knodel et al.	6,926,716 B2	8/2005	Baker et al.
6,777,838 B2	8/2004	Miekka et al.	6,929,641 B2	8/2005	Goble et al.
6,780,151 B2	8/2004	Grabover et al.	6,929,644 B2	8/2005	Truckai et al.
6,780,180 B1	8/2004	Goble et al.	6,931,830 B2	8/2005	Liao
6,783,524 B2	8/2004	Anderson et al.	6,932,218 B2	8/2005	Kosann et al.
6,786,382 B1	9/2004	Hoffman	6,932,810 B2	8/2005	Ryan
6,786,864 B2	9/2004	Matsuura et al.	6,936,042 B2	8/2005	Wallace et al.
6,786,896 B1	9/2004	Madhani et al.	D509,297 S	9/2005	Wells
6,790,173 B2	9/2004	Saadat et al.	D509,589 S	9/2005	Wells
6,793,652 B1	9/2004	Whitman et al.	6,939,358 B2	9/2005	Palacios et al.
6,793,661 B2	9/2004	Hamilton et al.	6,942,662 B2	9/2005	Goble et al.
6,793,663 B2	9/2004	Kneifel et al.	6,942,674 B2	9/2005	Belef et al.
6,802,843 B2	10/2004	Truckai et al.	6,945,444 B2	9/2005	Gresham et al.
6,805,273 B2	10/2004	Bilotti et al.	6,945,981 B2	9/2005	Donofrio et al.
6,806,808 B1	10/2004	Watters et al.	6,953,138 B1	10/2005	Dworak et al.
6,808,525 B2	10/2004	Latterell et al.	6,953,139 B2	10/2005	Milliman et al.
6,814,741 B2	11/2004	Bowman et al.	6,958,035 B2	10/2005	Friedman et al.
6,817,508 B1	11/2004	Racenet et al.	6,959,851 B2	11/2005	Heinrich
6,817,509 B2	11/2004	Geiste et al.	6,959,852 B2	11/2005	Shelton, IV et al.
6,817,974 B2	11/2004	Cooper et al.	6,960,107 B1	11/2005	Schaub et al.
6,818,018 B1	11/2004	Sawhney	6,960,163 B2	11/2005	Ewers et al.
6,820,791 B2	11/2004	Adams	6,960,220 B2	11/2005	Marino et al.
6,821,273 B2	11/2004	Mollenauer	6,964,363 B2	11/2005	Wales et al.
6,821,282 B2	11/2004	Perry et al.	6,966,907 B2	11/2005	Goble
6,821,284 B2	11/2004	Sturtz et al.	6,966,909 B2	11/2005	Marshall et al.
6,827,246 B2	12/2004	Sullivan et al.	6,971,988 B2	12/2005	Orban, III
6,827,712 B2	12/2004	Tovey et al.	6,972,199 B2	12/2005	Lebouitz et al.
6,827,725 B2	12/2004	Batchelor et al.	6,974,462 B2	12/2005	Sater
6,828,902 B2	12/2004	Casden	6,978,921 B2	12/2005	Shelton, IV et al.
6,830,174 B2	12/2004	Hillstead et al.	6,978,922 B2	12/2005	Bilotti et al.
6,831,629 B2	12/2004	Nishino et al.	6,981,628 B2	1/2006	Wales
6,832,998 B2	12/2004	Goble	6,981,941 B2	1/2006	Whitman et al.
6,834,001 B2	12/2004	Myono	6,981,978 B2	1/2006	Gannoe
6,835,173 B2	12/2004	Couvillon, Jr.	6,981,983 B1	1/2006	Rosenblatt et al.
6,835,199 B2	12/2004	McGuckin, Jr. et al.	6,984,203 B2	1/2006	Tartaglia et al.
6,835,336 B2	12/2004	Watt	6,984,231 B2	1/2006	Goble et al.
6,837,846 B2	1/2005	Jaffe et al.	6,986,451 B1	1/2006	Mastri et al.
6,838,493 B2	1/2005	Williams et al.	6,988,649 B2	1/2006	Shelton, IV et al.
6,840,423 B2	1/2005	Adams et al.	6,988,650 B2	1/2006	Schwemberger et al.
6,843,403 B2	1/2005	Whitman	6,990,731 B2	1/2006	Haytayan
6,843,789 B2	1/2005	Goble	6,990,796 B2	1/2006	Schnipke et al.
6,843,793 B2	1/2005	Brock et al.	6,994,708 B2	2/2006	Manzo
6,846,307 B2	1/2005	Whitman et al.	6,995,729 B2	2/2006	Govari et al.
6,846,308 B2	1/2005	Whitman et al.	6,997,931 B2	2/2006	Sauer et al.
6,846,309 B2	1/2005	Whitman et al.	7,000,818 B2	2/2006	Shelton, IV et al.
6,849,071 B2	2/2005	Whitman et al.	7,000,819 B2	2/2006	Swayze et al.
6,850,817 B1	2/2005	Green	7,001,380 B2	2/2006	Goble
6,858,005 B2	2/2005	Ohline et al.	7,001,408 B2	2/2006	Knodel et al.
RE38,708 E	3/2005	Bolanos et al.	7,008,435 B2	3/2006	Cummins
D502,994 S	3/2005	Blake, III	7,009,039 B2	3/2006	Yayon et al.
6,861,142 B1	3/2005	Wilkie et al.	7,011,657 B2	3/2006	Truckai et al.
6,863,668 B2	3/2005	Gillespie et al.	7,018,357 B2	3/2006	Emmons
6,863,694 B1	3/2005	Boyce et al.	7,018,390 B2	3/2006	Turovskiy et al.
6,866,178 B2	3/2005	Adams et al.	7,023,159 B2	4/2006	Gorti et al.
6,866,671 B2	3/2005	Tierney et al.	7,025,743 B2	4/2006	Mann et al.
6,867,248 B1	3/2005	Martin et al.	7,029,435 B2	4/2006	Nakao
6,869,435 B2	3/2005	Blake, III	7,032,798 B2	4/2006	Whitman et al.
6,872,214 B2	3/2005	Sonnenschein et al.	7,032,799 B2	4/2006	Viola et al.
6,874,669 B2	4/2005	Adams et al.	7,033,356 B2	4/2006	Latterell et al.
6,877,647 B2	4/2005	Green et al.	7,036,680 B1	5/2006	Flannery
			7,037,344 B2	5/2006	Kagan et al.
			7,041,102 B2	5/2006	Truckai et al.
			7,041,868 B2	5/2006	Greene et al.
			7,043,852 B2	5/2006	Hayashida et al.

(56)

References Cited

U.S. PATENT DOCUMENTS

7,044,352 B2	5/2006	Shelton, IV et al.	7,147,140 B2	12/2006	Wukusick et al.
7,044,353 B2	5/2006	Mastri et al.	7,147,637 B2	12/2006	Goble
7,048,687 B1	5/2006	Reuss et al.	7,147,650 B2	12/2006	Lee
7,048,745 B2	5/2006	Tierney et al.	7,150,748 B2	12/2006	Ebbutt et al.
7,052,494 B2	5/2006	Goble et al.	7,153,300 B2	12/2006	Goble
7,052,499 B2	5/2006	Steger et al.	7,156,824 B2	1/2007	Rosenman
7,055,730 B2	6/2006	Ehrenfels et al.	7,156,863 B2	1/2007	Sonnenschein et al.
7,055,731 B2	6/2006	Shelton, IV et al.	7,159,750 B2	1/2007	Racenet et al.
7,056,284 B2	6/2006	Martone et al.	7,160,299 B2	1/2007	Baily
7,056,330 B2	6/2006	Gayton	7,161,036 B2	1/2007	Oikawa et al.
7,059,331 B2	6/2006	Adams et al.	7,168,604 B2	1/2007	Milliman et al.
7,059,508 B2	6/2006	Shelton, IV et al.	7,172,104 B2	2/2007	Scirica et al.
7,063,671 B2	6/2006	Couvillon, Jr.	7,172,593 B2	2/2007	Trieu et al.
7,063,712 B2	6/2006	Vargas et al.	7,179,223 B2	2/2007	Motoki et al.
7,066,879 B2	6/2006	Fowler et al.	7,179,267 B2	2/2007	Nolan et al.
7,066,944 B2	6/2006	Laufer et al.	7,182,239 B1	2/2007	Myers
7,067,038 B2	6/2006	Trokhan et al.	7,182,763 B2	2/2007	Nardella
7,070,083 B2	7/2006	Jankowski	7,183,737 B2	2/2007	Kitagawa
7,070,559 B2	7/2006	Adams et al.	7,188,758 B2	3/2007	Viola et al.
7,070,597 B2	7/2006	Truckai et al.	7,189,207 B2	3/2007	Viola
7,071,287 B2	7/2006	Rhine et al.	7,195,627 B2	3/2007	Amoah et al.
7,075,770 B1	7/2006	Smith	7,199,537 B2	4/2007	Okamura et al.
7,077,856 B2	7/2006	Whitman	7,202,653 B2	4/2007	Pai
7,080,769 B2	7/2006	Vresh et al.	7,204,404 B2	4/2007	Nguyen et al.
7,081,114 B2	7/2006	Rashidi	7,204,835 B2	4/2007	Latterell et al.
7,083,073 B2	8/2006	Yoshie et al.	7,207,233 B2	4/2007	Wadge
7,083,075 B2	8/2006	Swayze et al.	7,207,471 B2	4/2007	Heinrich et al.
7,083,571 B2	8/2006	Wang et al.	7,207,472 B2	4/2007	Wukusick et al.
7,083,615 B2	8/2006	Peterson et al.	7,207,556 B2	4/2007	Saitoh et al.
7,083,619 B2	8/2006	Truckai et al.	7,208,005 B2	4/2007	Frecker et al.
7,083,620 B2	8/2006	Jahns et al.	7,210,609 B2	5/2007	Leiboff et al.
7,087,049 B2	8/2006	Nowlin et al.	7,211,081 B2	5/2007	Goble
7,087,054 B2	8/2006	Truckai et al.	7,211,084 B2	5/2007	Goble et al.
7,087,071 B2	8/2006	Nicholas et al.	7,211,092 B2	5/2007	Hughett
7,090,637 B2	8/2006	Danitz et al.	7,213,736 B2	5/2007	Wales et al.
7,090,673 B2	8/2006	Dycus et al.	7,214,224 B2	5/2007	Goble
7,090,683 B2	8/2006	Brock et al.	7,214,232 B2	5/2007	Bowman et al.
7,090,684 B2	8/2006	McGuckin, Jr. et al.	7,217,285 B2	5/2007	Vargas et al.
7,094,202 B2	8/2006	Nobis et al.	7,220,260 B2	5/2007	Fleming et al.
7,094,247 B2	8/2006	Monassevitch et al.	7,220,272 B2	5/2007	Weadock
7,097,089 B2	8/2006	Marczyk	7,225,963 B2	6/2007	Scirica
7,097,644 B2	8/2006	Long	7,225,964 B2	6/2007	Mastri et al.
7,097,650 B2	8/2006	Weller et al.	7,234,624 B2	6/2007	Gresham et al.
7,098,794 B2	8/2006	Lindsay et al.	7,235,089 B1	6/2007	McGuckin, Jr.
7,100,949 B2	9/2006	Williams et al.	7,235,302 B2	6/2007	Jing et al.
7,104,741 B2	9/2006	Krohn	7,237,708 B1	7/2007	Guy et al.
7,108,695 B2	9/2006	Witt et al.	7,238,195 B2	7/2007	Viola
7,108,701 B2	9/2006	Evens et al.	7,241,288 B2	7/2007	Braun
7,108,709 B2	9/2006	Cummins	7,241,289 B2	7/2007	Braun
7,111,768 B2	9/2006	Cummins et al.	7,246,734 B2	7/2007	Shelton, IV
7,111,769 B2	9/2006	Wales et al.	7,247,161 B2	7/2007	Johnston et al.
7,112,214 B2	9/2006	Peterson et al.	7,252,660 B2	8/2007	Kunz
RE39,358 E	10/2006	Goble	7,255,696 B2	8/2007	Goble et al.
7,114,642 B2	10/2006	Whitman	7,256,695 B2	8/2007	Hamel et al.
7,118,582 B1	10/2006	Wang et al.	7,258,262 B2	8/2007	Mastri et al.
7,119,534 B2	10/2006	Butzmann	7,258,546 B2	8/2007	Beier et al.
7,121,446 B2	10/2006	Arad et al.	7,260,431 B2	8/2007	Libbus et al.
7,122,028 B2	10/2006	Looper et al.	7,265,374 B2	9/2007	Lee et al.
7,125,409 B2	10/2006	Truckai et al.	7,267,679 B2	9/2007	McGuckin, Jr. et al.
7,126,303 B2	10/2006	Farritor et al.	7,267,682 B1	9/2007	Bender et al.
7,128,253 B2	10/2006	Mastri et al.	7,273,483 B2	9/2007	Wiener et al.
7,128,254 B2	10/2006	Shelton, IV et al.	7,278,562 B2	10/2007	Mastri et al.
7,128,748 B2	10/2006	Mooradian et al.	7,278,563 B1	10/2007	Green
7,131,445 B2	11/2006	Amoah	7,278,949 B2	10/2007	Bader
7,133,601 B2	11/2006	Phillips et al.	7,278,994 B2	10/2007	Goble
7,134,587 B2	11/2006	Schwemberger et al.	7,282,048 B2	10/2007	Goble et al.
7,137,981 B2	11/2006	Long	7,286,850 B2	10/2007	Frielink et al.
7,140,527 B2	11/2006	Ehrenfels et al.	7,287,682 B1	10/2007	Ezzat et al.
7,140,528 B2	11/2006	Shelton, IV	7,289,139 B2	10/2007	Amling et al.
7,143,923 B2	12/2006	Shelton, IV et al.	7,293,685 B2	11/2007	Ehrenfels et al.
7,143,924 B2	12/2006	Scirica et al.	7,295,907 B2	11/2007	Lu et al.
7,143,925 B2	12/2006	Shelton, IV et al.	7,296,722 B2	11/2007	Ivanko
7,143,926 B2	12/2006	Shelton, IV et al.	7,296,724 B2	11/2007	Green et al.
7,147,138 B2	12/2006	Shelton, IV	7,297,149 B2	11/2007	Vitali et al.
7,147,139 B2	12/2006	Schwemberger et al.	7,300,373 B2	11/2007	Jinno et al.
			7,300,450 B2	11/2007	Vleugels et al.
			7,300,450 B2	11/2007	Milliman et al.
			7,303,106 B2	12/2007	Milliman et al.
			7,303,107 B2	12/2007	Milliman et al.
			7,303,108 B2	12/2007	Shelton, IV

(56)

References Cited

U.S. PATENT DOCUMENTS

7,303,502 B2	12/2007	Thompson	7,434,717 B2	10/2008	Shelton, IV et al.
7,303,556 B2	12/2007	Metzger	7,438,209 B1	10/2008	Hess et al.
7,306,597 B2	12/2007	Manzo	7,438,718 B2	10/2008	Milliman et al.
7,308,998 B2	12/2007	Mastri et al.	7,439,354 B2	10/2008	Lenges et al.
7,322,975 B2	1/2008	Goble et al.	7,441,684 B2	10/2008	Shelton, IV et al.
7,322,994 B2	1/2008	Nicholas et al.	7,441,685 B1	10/2008	Boudreaux
7,324,572 B2	1/2008	Chang	7,442,201 B2	10/2008	Pugsley et al.
7,326,203 B2	2/2008	Papineau et al.	7,448,525 B2	11/2008	Shelton, IV et al.
7,326,213 B2	2/2008	Benderev et al.	7,451,904 B2	11/2008	Shelton, IV
7,328,828 B2	2/2008	Ortiz et al.	7,455,208 B2	11/2008	Wales et al.
7,328,829 B2	2/2008	Arad et al.	7,455,676 B2	11/2008	Holsten et al.
7,330,004 B2	2/2008	DeJonge et al.	7,455,682 B2	11/2008	Viola
7,331,340 B2	2/2008	Barney	7,461,767 B2	12/2008	Viola et al.
7,331,969 B1	2/2008	Inganas et al.	7,462,187 B2	12/2008	Johnston et al.
7,334,717 B2	2/2008	Rethy et al.	7,464,846 B2	12/2008	Shelton, IV et al.
7,334,718 B2	2/2008	McAlister et al.	7,464,847 B2	12/2008	Viola et al.
7,335,199 B2	2/2008	Goble et al.	7,464,849 B2	12/2008	Shelton, IV et al.
7,336,048 B2	2/2008	Lohr	7,467,740 B2	12/2008	Shelton, IV et al.
7,336,184 B2	2/2008	Smith et al.	7,467,849 B2	12/2008	Silverbrook et al.
7,338,513 B2	3/2008	Lee et al.	7,472,814 B2	1/2009	Mastri et al.
7,341,591 B2	3/2008	Grinberg	7,472,815 B2	1/2009	Shelton, IV et al.
7,343,920 B2	3/2008	Toby et al.	7,472,816 B2	1/2009	Holsten et al.
7,344,532 B2	3/2008	Goble et al.	7,473,253 B2	1/2009	Dycus et al.
7,348,763 B1	3/2008	Reinhart et al.	7,473,263 B2	1/2009	Johnston et al.
RE40,237 E	4/2008	Bilotti et al.	7,476,237 B2	1/2009	Taniguchi et al.
7,351,258 B2	4/2008	Ricotta et al.	7,479,608 B2	1/2009	Smith
7,354,447 B2	4/2008	Shelton, IV et al.	7,481,347 B2	1/2009	Roy
7,354,502 B2	4/2008	Polat et al.	7,481,348 B2	1/2009	Marczyk
7,357,287 B2	4/2008	Shelton, IV et al.	7,481,349 B2	1/2009	Holsten et al.
7,357,806 B2	4/2008	Rivera et al.	7,481,824 B2	1/2009	Boudreaux et al.
7,361,195 B2	4/2008	Schwartz et al.	7,485,133 B2	2/2009	Cannon et al.
7,364,060 B2	4/2008	Milliman	7,485,142 B2	2/2009	Milo
7,364,061 B2	4/2008	Swayze et al.	7,487,899 B2	2/2009	Shelton, IV et al.
7,367,973 B2	5/2008	Manzo et al.	7,490,749 B2	2/2009	Schall et al.
7,377,918 B2	5/2008	Amoah	7,494,039 B2	2/2009	Racenet et al.
7,377,928 B2	5/2008	Zubik et al.	7,494,499 B2	2/2009	Nagase et al.
7,380,695 B2	6/2008	Doll et al.	7,494,501 B2	2/2009	Ahlberg et al.
7,380,696 B2	6/2008	Shelton, IV et al.	7,500,979 B2	3/2009	Hueil et al.
7,384,417 B2	6/2008	Cucin	7,501,198 B2	3/2009	Barley et al.
7,386,730 B2	6/2008	Uchikubo	7,503,474 B2	3/2009	Hillstead et al.
7,388,217 B2	6/2008	Buschbeck et al.	7,506,790 B2	3/2009	Shelton, IV
7,391,173 B2	6/2008	Schena	7,506,791 B2	3/2009	Omaits et al.
7,396,356 B2	7/2008	Mollenauer	7,507,202 B2	3/2009	Schoellhorn
7,397,364 B2	7/2008	Govari	7,510,107 B2	3/2009	Timm et al.
7,398,907 B2	7/2008	Racenet et al.	7,510,566 B2	3/2009	Jacobs et al.
7,398,908 B2	7/2008	Holsten et al.	7,513,408 B2	4/2009	Shelton, IV et al.
7,400,752 B2	7/2008	Zacharias	7,517,356 B2	4/2009	Heinrich
7,401,721 B2	7/2008	Holsten et al.	7,524,320 B2	4/2009	Tierney et al.
7,404,508 B2	7/2008	Smith et al.	7,530,984 B2	5/2009	Sonnenschein et al.
7,404,509 B2	7/2008	Ortiz et al.	7,530,985 B2	5/2009	Takemoto et al.
7,404,822 B2	7/2008	Viart et al.	7,533,906 B2	5/2009	Luetngen et al.
7,407,074 B2	8/2008	Ortiz et al.	7,534,259 B2	5/2009	Lashinski et al.
7,407,075 B2	8/2008	Holsten et al.	7,543,730 B1	6/2009	Marczyk
7,407,076 B2	8/2008	Racenet et al.	7,546,939 B2	6/2009	Adams et al.
7,407,077 B2	8/2008	Ortiz et al.	7,546,940 B2	6/2009	Milliman et al.
7,407,078 B2	8/2008	Shelton, IV et al.	7,547,312 B2	6/2009	Bauman et al.
7,410,086 B2	8/2008	Ortiz et al.	7,549,563 B2	6/2009	Mather et al.
7,413,563 B2	8/2008	Corcoran et al.	7,549,564 B2	6/2009	Boudreaux
7,416,101 B2	8/2008	Shelton, IV et al.	7,549,998 B2	6/2009	Braun
7,418,078 B2	8/2008	Blanz et al.	7,552,854 B2	6/2009	Wixey et al.
RE40,514 E	9/2008	Mastri et al.	7,556,185 B2	7/2009	Viola
7,419,080 B2	9/2008	Smith et al.	7,556,186 B2	7/2009	Milliman
7,419,081 B2	9/2008	Ehrenfels et al.	7,556,647 B2	7/2009	Drews et al.
7,419,321 B2	9/2008	Tereschouk	7,559,449 B2	7/2009	Viola
7,419,495 B2	9/2008	Menn et al.	7,559,450 B2	7/2009	Wales et al.
7,422,136 B1	9/2008	Marczyk	7,559,452 B2	7/2009	Wales et al.
7,422,138 B2	9/2008	Bilotti et al.	7,559,937 B2	7/2009	de la Torre et al.
7,422,139 B2	9/2008	Shelton, IV et al.	7,563,862 B2	7/2009	Sieg et al.
7,424,965 B2	9/2008	Racenet et al.	7,565,993 B2	7/2009	Milliman et al.
7,427,607 B2	9/2008	Suzuki	7,566,300 B2	7/2009	Devierre et al.
7,431,188 B1	10/2008	Marczyk	7,567,045 B2	7/2009	Fristedt
7,431,189 B2	10/2008	Shelton, IV et al.	7,568,603 B2	8/2009	Shelton, IV et al.
7,431,694 B2	10/2008	Stefanchik et al.	7,568,604 B2	8/2009	Ehrenfels et al.
7,431,730 B2	10/2008	Viola	7,568,619 B2	8/2009	Todd et al.
7,434,715 B2	10/2008	Shelton, IV et al.	7,575,144 B2	8/2009	Ortiz et al.
			7,588,174 B2	9/2009	Holsten et al.
			7,588,175 B2	9/2009	Timm et al.
			7,588,176 B2	9/2009	Timm et al.
			7,588,177 B2	9/2009	Racenet

(56)

References Cited

U.S. PATENT DOCUMENTS

7,591,783 B2	9/2009	Boulais et al.	7,714,239 B2	5/2010	Smith
7,597,229 B2	10/2009	Boudreaux et al.	7,717,312 B2	5/2010	Beetel
7,597,230 B2	10/2009	Racenet et al.	7,717,313 B2	5/2010	Criscuolo et al.
7,600,663 B2	10/2009	Green	7,717,846 B2	5/2010	Zirps et al.
7,604,150 B2	10/2009	Boudreaux	7,718,180 B2	5/2010	Karp
7,604,151 B2	10/2009	Hess et al.	7,718,556 B2	5/2010	Matsuda et al.
7,607,557 B2	10/2009	Shelton, IV et al.	7,721,931 B2	5/2010	Shelton, IV et al.
7,611,038 B2	11/2009	Racenet et al.	7,721,933 B2	5/2010	Ehrenfels et al.
7,611,474 B2	11/2009	Hibner et al.	7,721,934 B2	5/2010	Shelton, IV et al.
7,615,003 B2	11/2009	Stefanchik et al.	7,721,936 B2	5/2010	Shalton, IV et al.
7,615,067 B2	11/2009	Lee et al.	7,722,527 B2	5/2010	Bouchier et al.
7,617,961 B2	11/2009	Viola	7,722,607 B2	5/2010	Dumbauld et al.
D605,762 S	12/2009	Nalagatla et al.	7,722,610 B2	5/2010	Viola et al.
7,624,902 B2	12/2009	Marczyk et al.	7,726,537 B2	6/2010	Olson et al.
7,624,903 B2	12/2009	Green et al.	7,726,538 B2	6/2010	Holsten et al.
7,625,370 B2	12/2009	Hart et al.	7,726,539 B2	6/2010	Holsten et al.
7,631,793 B2	12/2009	Rethy et al.	7,727,954 B2	6/2010	McKay
7,631,794 B2	12/2009	Rethy et al.	7,729,742 B2	6/2010	Govari
7,635,074 B2	12/2009	Olson et al.	7,731,072 B2	6/2010	Timm et al.
7,637,409 B2	12/2009	Marczyk	7,731,073 B2	6/2010	Wixey et al.
7,637,410 B2	12/2009	Marczyk	7,731,724 B2	6/2010	Huitema et al.
7,638,958 B2	12/2009	Philipp et al.	7,735,703 B2	6/2010	Morgan et al.
7,641,091 B2 *	1/2010	Olson A61B 17/07207 227/175.1	7,736,374 B2	6/2010	Vaughan et al.
7,641,092 B2	1/2010	Kruszynski et al.	7,738,971 B2	6/2010	Swayze et al.
7,641,093 B2	1/2010	Doll et al.	7,740,159 B2	6/2010	Shelton, IV et al.
7,641,095 B2	1/2010	Viola	7,743,960 B2	6/2010	Whitman et al.
7,644,783 B2	1/2010	Roberts et al.	7,744,624 B2	6/2010	Bettuchi
7,644,848 B2	1/2010	Swayze et al.	7,744,627 B2	6/2010	Orban, III et al.
7,645,230 B2	1/2010	Mikkaichi et al.	7,744,628 B2	6/2010	Viola
7,648,457 B2	1/2010	Stefanchik et al.	7,748,587 B2	7/2010	Haramiishi et al.
7,648,519 B2	1/2010	Lee et al.	7,749,204 B2	7/2010	Dhanaraj et al.
7,651,017 B2	1/2010	Ortiz et al.	7,751,870 B2	7/2010	Whitman
7,651,498 B2	1/2010	Shifrin et al.	7,753,245 B2	7/2010	Boudreaux et al.
7,654,431 B2	2/2010	Hueil et al.	7,753,904 B2	7/2010	Shelton, IV et al.
7,655,288 B2	2/2010	Bauman et al.	7,758,612 B2	7/2010	Shipp
7,656,131 B2	2/2010	Embrey et al.	7,766,207 B2	8/2010	Mather et al.
7,658,311 B2	2/2010	Boudreaux	7,766,209 B2	8/2010	Baxter, III et al.
7,658,312 B2	2/2010	Vidal et al.	7,766,210 B2	8/2010	Shelton, IV et al.
7,659,219 B2	2/2010	Biran et al.	7,766,821 B2	8/2010	Brunnen et al.
7,662,161 B2	2/2010	Briganti et al.	7,766,894 B2	8/2010	Weitzner et al.
7,665,646 B2	2/2010	Prommersberger	7,770,773 B2	8/2010	Whitman et al.
7,665,647 B2	2/2010	Shelton, IV et al.	7,770,774 B2	8/2010	Mastri et al.
7,669,746 B2	3/2010	Shelton, IV	7,770,775 B2	8/2010	Shelton, IV et al.
7,669,747 B2	3/2010	Weisenburgh, II et al.	7,770,776 B2	8/2010	Chen et al.
7,670,334 B2	3/2010	Hueil et al.	7,771,396 B2	8/2010	Stefanchik et al.
7,673,780 B2	3/2010	Shelton, IV et al.	7,772,720 B2	8/2010	McGee et al.
7,673,781 B2	3/2010	Swayze et al.	7,776,037 B2	8/2010	Odom
7,673,782 B2	3/2010	Hess et al.	7,776,060 B2	8/2010	Mooradian et al.
7,673,783 B2	3/2010	Morgan et al.	7,778,004 B2	8/2010	Nerheim et al.
7,674,253 B2	3/2010	Fisher et al.	7,780,054 B2	8/2010	Wales
7,674,255 B2	3/2010	Braun	7,780,055 B2	8/2010	Scirica et al.
7,674,263 B2	3/2010	Ryan	7,780,663 B2	8/2010	Yates et al.
7,674,270 B2	3/2010	Layer	7,780,685 B2	8/2010	Hunt et al.
7,682,307 B2	3/2010	Danitz et al.	7,784,662 B2	8/2010	Wales et al.
7,682,367 B2	3/2010	Shah et al.	7,784,663 B2	8/2010	Shelton, IV
7,686,201 B2	3/2010	Csiky	7,789,875 B2	9/2010	Brock et al.
7,686,826 B2	3/2010	Lee et al.	7,789,883 B2	9/2010	Takashino et al.
7,688,028 B2	3/2010	Phillips et al.	7,789,889 B2	9/2010	Zubik et al.
7,691,098 B2	4/2010	Wallace et al.	7,793,812 B2	9/2010	Moore et al.
7,691,106 B2	4/2010	Schenberger et al.	7,794,475 B2	9/2010	Hess et al.
7,694,865 B2	4/2010	Scirica	7,798,386 B2	9/2010	Schall et al.
7,695,485 B2	4/2010	Whitman et al.	7,799,039 B2	9/2010	Shelton, IV et al.
7,699,204 B2	4/2010	Viola	7,799,044 B2	9/2010	Johnston et al.
7,699,835 B2	4/2010	Lee et al.	7,799,965 B2	9/2010	Patel et al.
7,699,844 B2	4/2010	Utlely et al.	7,803,151 B2	9/2010	Whitman
7,699,846 B2	4/2010	Ryan	7,806,871 B2	10/2010	Li et al.
7,699,856 B2	4/2010	Van Wyk et al.	7,806,891 B2	10/2010	Nowlin et al.
7,699,859 B2	4/2010	Bombard et al.	7,810,690 B2	10/2010	Bilotti et al.
7,699,860 B2	4/2010	Huitema et al.	7,810,691 B2	10/2010	Boyden et al.
7,703,653 B2	4/2010	Shah et al.	7,810,692 B2	10/2010	Hall et al.
7,708,180 B2	5/2010	Murray et al.	7,810,693 B2	10/2010	Broehl et al.
7,708,181 B2	5/2010	Cole et al.	7,815,092 B2	10/2010	Whitman et al.
7,708,182 B2	5/2010	Viola	7,815,565 B2	10/2010	Stefanchik et al.
7,708,758 B2	5/2010	Lee et al.	7,819,296 B2	10/2010	Hueil et al.
			7,819,297 B2	10/2010	Doll et al.
			7,819,298 B2	10/2010	Hall et al.
			7,819,299 B2	10/2010	Shelton, IV et al.
			7,819,884 B2	10/2010	Lee et al.
			7,819,886 B2	10/2010	Whitfield et al.

(56)

References Cited

U.S. PATENT DOCUMENTS

7,823,592 B2	11/2010	Bettuchi et al.	7,918,867 B2	4/2011	Dana et al.
7,823,760 B2	11/2010	Zemlok et al.	7,918,873 B2	4/2011	Cummins
7,824,401 B2	11/2010	Manzo et al.	7,922,061 B2	4/2011	Shelton, IV et al.
7,824,426 B2	11/2010	Racenet et al.	7,922,063 B2	4/2011	Zemlok et al.
7,828,189 B2	11/2010	Holsten et al.	7,922,743 B2	4/2011	Heinrich et al.
7,828,794 B2	11/2010	Sartor	7,926,691 B2	4/2011	Viola et al.
7,828,808 B2	11/2010	Hinman et al.	7,927,328 B2	4/2011	Orszulak et al.
7,832,408 B2	11/2010	Shelton, IV et al.	7,928,281 B2	4/2011	Augustine
7,832,611 B2	11/2010	Boyden et al.	7,931,660 B2	4/2011	Aranyi et al.
7,832,612 B2	11/2010	Baxter, III et al.	7,931,695 B2	4/2011	Ringeisen
7,833,234 B2	11/2010	Bailly et al.	7,934,630 B2	5/2011	Shelton, IV et al.
7,836,400 B2	11/2010	May et al.	7,934,631 B2	5/2011	Balbierz et al.
7,837,079 B2	11/2010	Holsten et al.	7,935,773 B2	5/2011	Hadba et al.
7,837,080 B2	11/2010	Schwemberger	7,938,307 B2	5/2011	Bettuchi
7,837,081 B2	11/2010	Holsten et al.	7,941,865 B2	5/2011	Seman, Jr. et al.
7,837,694 B2	11/2010	Tethrake et al.	7,942,301 B2	5/2011	Sater
7,838,789 B2	11/2010	Stoffers et al.	7,942,303 B2	5/2011	Shah
7,841,503 B2	11/2010	Sonnenschein et al.	7,942,890 B2	5/2011	D'Agostino et al.
7,842,025 B2	11/2010	Coleman et al.	7,944,175 B2	5/2011	Mori et al.
7,842,028 B2	11/2010	Lee	7,946,453 B2	5/2011	Voegele et al.
7,845,533 B2	12/2010	Marczyk et al.	7,950,560 B2	5/2011	Zemlok et al.
7,845,534 B2	12/2010	Viola et al.	7,950,561 B2	5/2011	Aranyi
7,845,535 B2	12/2010	Scirica	7,951,071 B2	5/2011	Whitman et al.
7,845,536 B2	12/2010	Viola et al.	7,951,166 B2	5/2011	Orban, III et al.
7,845,537 B2	12/2010	Shelton, IV et al.	7,954,682 B2	6/2011	Giordano et al.
7,846,149 B2	12/2010	Jankowski	7,954,684 B2	6/2011	Boudreaux
7,850,623 B2	12/2010	Griffin et al.	7,954,686 B2	6/2011	Baxter, III et al.
7,850,642 B2	12/2010	Moll et al.	7,954,687 B2	6/2011	Zemlok et al.
7,850,982 B2	12/2010	Stopek et al.	7,954,688 B2	6/2011	Argentine et al.
7,854,736 B2	12/2010	Ryan	7,955,257 B2	6/2011	Frasier et al.
7,857,183 B2	12/2010	Shelton, IV	7,959,050 B2	6/2011	Smith et al.
7,857,185 B2	12/2010	Swayze et al.	7,959,051 B2	6/2011	Smith et al.
7,857,186 B2	12/2010	Baxter, III et al.	7,959,052 B2	6/2011	Sonnenschein et al.
7,857,813 B2	12/2010	Schmitz et al.	7,963,432 B2	6/2011	Knodel et al.
7,861,906 B2	1/2011	Doll et al.	7,963,433 B2	6/2011	Whitman et al.
7,862,579 B2	1/2011	Ortiz et al.	7,963,963 B2	6/2011	Francischelli et al.
7,866,525 B2	1/2011	Scirica	7,963,964 B2	6/2011	Santilli et al.
7,866,527 B2	1/2011	Hall et al.	7,966,799 B2	6/2011	Morgan et al.
7,866,528 B2	1/2011	Olson et al.	7,967,178 B2	6/2011	Scirica et al.
7,870,989 B2	1/2011	Viola et al.	7,967,179 B2	6/2011	Olson et al.
7,871,418 B2	1/2011	Thompson et al.	7,967,180 B2	6/2011	Scirica
7,879,070 B2	2/2011	Ortiz et al.	7,967,181 B2	6/2011	Viola et al.
7,883,465 B2	2/2011	Donofrio et al.	7,967,839 B2	6/2011	Flock et al.
7,886,951 B2	2/2011	Hessler	7,972,298 B2	7/2011	Wallace et al.
7,886,952 B2	2/2011	Scirica et al.	7,976,563 B2	7/2011	Summerer
7,887,530 B2	2/2011	Zemlok et al.	7,980,443 B2	7/2011	Scheib et al.
7,887,535 B2	2/2011	Lands et al.	7,988,015 B2	8/2011	Mason, II et al.
7,887,563 B2	2/2011	Cummins	7,988,026 B2	8/2011	Knodel et al.
7,891,531 B1	2/2011	Ward	7,988,027 B2	8/2011	Olson et al.
7,891,532 B2	2/2011	Mastri et al.	7,988,028 B2	8/2011	Farascioni et al.
7,892,245 B2	2/2011	Liddicoat et al.	7,988,779 B2	8/2011	Disalvo et al.
7,893,586 B2	2/2011	West et al.	7,992,757 B2	8/2011	Wheeler et al.
7,896,214 B2	3/2011	Farascioni	7,993,360 B2	8/2011	Hacker et al.
7,896,215 B2	3/2011	Adams et al.	7,997,468 B2	8/2011	Farascioni
7,896,877 B2	3/2011	Hall et al.	7,997,469 B2	8/2011	Olson et al.
7,896,895 B2	3/2011	Boudreaux et al.	8,002,696 B2	8/2011	Suzuki
7,900,805 B2	3/2011	Shelton, IV et al.	8,002,784 B2	8/2011	Jinno et al.
7,905,380 B2	3/2011	Shelton, IV et al.	8,002,785 B2	8/2011	Weiss et al.
7,905,381 B2	3/2011	Baxter, III et al.	8,002,795 B2	8/2011	Beetel
7,905,889 B2	3/2011	Catanese, III et al.	8,006,365 B2	8/2011	Levin et al.
7,905,893 B2	3/2011	Kuhns et al.	8,006,885 B2	8/2011	Marczyk
7,905,902 B2	3/2011	Huitema et al.	8,006,889 B2	8/2011	Adams et al.
7,909,039 B2	3/2011	Hur	8,007,511 B2	8/2011	Brock et al.
7,909,191 B2	3/2011	Baker et al.	8,007,513 B2	8/2011	Nalagatla et al.
7,909,220 B2	3/2011	Viola	8,011,550 B2	9/2011	Aranyi et al.
7,909,221 B2	3/2011	Viola et al.	8,011,551 B2	9/2011	Marczyk et al.
7,913,891 B2	3/2011	Doll et al.	8,011,553 B2	9/2011	Mastri et al.
7,913,893 B2	3/2011	Mastri et al.	8,011,555 B2	9/2011	Tarinelli et al.
7,914,543 B2	3/2011	Roth et al.	8,012,170 B2	9/2011	Whitman et al.
7,914,551 B2	3/2011	Ortiz et al.	8,016,176 B2	9/2011	Kasvikis et al.
7,918,230 B2	4/2011	Whitman et al.	8,016,177 B2	9/2011	Bettuchi et al.
7,918,376 B1	4/2011	Knodel et al.	8,016,178 B2	9/2011	Olson et al.
7,918,377 B2	4/2011	Measamer et al.	8,016,849 B2	9/2011	Wenchell
7,918,845 B2	4/2011	Saadat et al.	8,016,855 B2	9/2011	Whitman et al.
7,918,848 B2	4/2011	Lau et al.	8,016,858 B2	9/2011	Whitman
			8,016,881 B2	9/2011	Furst
			8,020,742 B2	9/2011	Marczyk
			8,020,743 B2	9/2011	Shelton, IV
			8,021,375 B2	9/2011	Aldrich et al.

(56)

References Cited

U.S. PATENT DOCUMENTS

8,021,377 B2	9/2011	Eskuri	8,157,793 B2	4/2012	Omori et al.
8,025,199 B2	9/2011	Whitman et al.	8,161,977 B2	4/2012	Shelton, IV et al.
8,028,883 B2	10/2011	Stopek	8,162,138 B2	4/2012	Bettenhausen et al.
8,028,884 B2	10/2011	Sniffin et al.	8,162,197 B2	4/2012	Mastri et al.
8,028,885 B2	10/2011	Smith et al.	8,167,185 B2	5/2012	Shelton, IV et al.
8,033,442 B2	10/2011	Racenet et al.	8,167,895 B2	5/2012	D'Agostino et al.
8,034,077 B2	10/2011	Smith et al.	8,167,898 B1	5/2012	Schaller et al.
8,034,363 B2	10/2011	Li et al.	8,170,241 B2	5/2012	Roe et al.
8,035,487 B2	10/2011	Malackowski	8,172,120 B2	5/2012	Boyden et al.
8,037,591 B2	10/2011	Spivey et al.	8,172,122 B2	5/2012	Kasvikis et al.
8,038,045 B2	10/2011	Bettuchi et al.	8,172,124 B2	5/2012	Shelton, IV et al.
8,038,046 B2	10/2011	Smith et al.	8,177,797 B2	5/2012	Shimoji et al.
8,038,686 B2	10/2011	Huitema et al.	8,180,458 B2	5/2012	Kane et al.
8,043,207 B2	10/2011	Adams	8,181,840 B2	5/2012	Milliman
8,043,328 B2	10/2011	Hahnen et al.	8,186,555 B2	5/2012	Shelton, IV et al.
8,047,236 B2	11/2011	Perry	8,186,556 B2	5/2012	Viola
8,048,503 B2	11/2011	Farnsworth et al.	8,186,560 B2	5/2012	Hess et al.
8,056,787 B2	11/2011	Boudreaux et al.	8,191,752 B2	6/2012	Scirica
8,056,788 B2	11/2011	Mastri et al.	8,192,460 B2	6/2012	Orban, III et al.
8,056,789 B1	11/2011	White et al.	8,196,795 B2	6/2012	Moore et al.
8,057,508 B2	11/2011	Shelton, IV	8,196,796 B2	6/2012	Shelton, IV et al.
8,058,771 B2	11/2011	Giordano et al.	8,201,720 B2	6/2012	Hessler
8,061,576 B2	11/2011	Cappola	8,201,721 B2	6/2012	Zemlok et al.
8,062,330 B2	11/2011	Prommersberger et al.	8,202,549 B2	6/2012	Stucky et al.
8,066,167 B2	11/2011	Measamer et al.	8,205,779 B2	6/2012	Ma et al.
8,066,168 B2	11/2011	Vidal et al.	8,205,780 B2	6/2012	Sorrentino et al.
D650,074 S	12/2011	Hunt et al.	8,205,781 B2	6/2012	Baxter, III et al.
8,070,033 B2	12/2011	Milliman et al.	8,206,291 B2	6/2012	Fischvogt et al.
8,070,035 B2	12/2011	Holsten et al.	8,210,411 B2	7/2012	Yates et al.
8,070,743 B2	12/2011	Kagan et al.	8,210,414 B2	7/2012	Bettuchi et al.
8,075,571 B2	12/2011	Vitali et al.	8,210,415 B2	7/2012	Ward
8,083,118 B2	12/2011	Milliman et al.	8,210,416 B2	7/2012	Milliman et al.
8,083,119 B2	12/2011	Prommersberger	8,211,123 B2	7/2012	Gross et al.
8,083,120 B2	12/2011	Shelton, IV et al.	8,211,125 B2	7/2012	Spivey
8,084,001 B2	12/2011	Burns et al.	8,214,019 B2	7/2012	Govari et al.
8,085,013 B2	12/2011	Wei et al.	8,215,531 B2	7/2012	Shelton, IV et al.
8,087,563 B2	1/2012	Milliman et al.	8,215,533 B2	7/2012	Viola et al.
8,091,756 B2	1/2012	Viola	8,220,468 B2	7/2012	Cooper et al.
8,092,443 B2	1/2012	Bischoff	8,220,688 B2	7/2012	Laurent et al.
8,092,932 B2	1/2012	Phillips et al.	8,220,690 B2	7/2012	Hess et al.
8,096,458 B2	1/2012	Hessler	8,221,424 B2	7/2012	Cha
8,097,017 B2	1/2012	Viola	8,225,799 B2	7/2012	Bettuchi
8,100,310 B2	1/2012	Zemlok	8,225,980 B1	7/2012	Rivera
8,100,872 B2	1/2012	Patel	8,226,715 B2	7/2012	Hwang et al.
8,102,278 B2	1/2012	Deck et al.	8,227,946 B2	7/2012	Kim
8,105,350 B2	1/2012	Lee et al.	8,231,040 B2	7/2012	Zemlok et al.
8,108,072 B2	1/2012	Zhao et al.	8,231,042 B2	7/2012	Hessler et al.
8,109,426 B2	2/2012	Milliman et al.	8,231,043 B2	7/2012	Tarinelli et al.
8,110,208 B1	2/2012	Hen	8,236,010 B2	8/2012	Ortiz et al.
8,113,405 B2	2/2012	Milliman	8,241,271 B2	8/2012	Millman et al.
8,113,410 B2	2/2012	Hall et al.	8,241,308 B2	8/2012	Kortenbach et al.
8,114,100 B2	2/2012	Smith et al.	8,241,322 B2	8/2012	Whitman et al.
8,123,103 B2	2/2012	Milliman	8,245,594 B2	8/2012	Rogers et al.
8,123,766 B2	2/2012	Bauman et al.	8,245,898 B2	8/2012	Smith et al.
8,123,767 B2	2/2012	Bauman et al.	8,245,899 B2	8/2012	Swensgard et al.
8,127,975 B2	3/2012	Olson et al.	8,245,900 B2	8/2012	Scirica
8,127,976 B2	3/2012	Scirica et al.	8,245,901 B2	8/2012	Stopek
8,128,624 B2	3/2012	Couture et al.	8,246,637 B2	8/2012	Viola et al.
8,128,643 B2	3/2012	Aranyi et al.	8,256,654 B2	9/2012	Bettuchi et al.
8,128,645 B2	3/2012	Sonnenschein et al.	8,256,655 B2	9/2012	Sniffin et al.
8,132,703 B2	3/2012	Milliman et al.	8,256,656 B2	9/2012	Milliman et al.
8,132,706 B2	3/2012	Marczyk et al.	8,257,251 B2	9/2012	Shelton, IV et al.
8,136,712 B2	3/2012	Zingman	8,257,356 B2	9/2012	Bleich et al.
8,136,713 B2	3/2012	Hathaway et al.	8,257,391 B2	9/2012	Orban, III et al.
8,140,417 B2	3/2012	Shibata	8,257,634 B2	9/2012	Scirica
8,141,762 B2	3/2012	Bedi et al.	8,261,958 B1	9/2012	Knodel
8,141,763 B2	3/2012	Milliman	8,262,655 B2	9/2012	Ghabrial et al.
8,146,790 B2	4/2012	Milliman	8,267,300 B2	9/2012	Boudreaux
8,147,485 B2	4/2012	Wham et al.	8,267,924 B2	9/2012	Zemlok et al.
8,152,041 B2	4/2012	Kostrzewski	8,267,946 B2	9/2012	Whitfield et al.
8,157,145 B2	4/2012	Shelton, IV et al.	8,267,951 B2	9/2012	Wayne et al.
8,157,148 B2	4/2012	Scirica	8,269,121 B2	9/2012	Smith
8,157,151 B2	4/2012	Ingmanson et al.	8,272,553 B2	9/2012	Mastri et al.
8,157,152 B2	4/2012	Holsten et al.	8,272,554 B2	9/2012	Whitman et al.
8,157,153 B2	4/2012	Shelton, IV et al.	8,272,918 B2	9/2012	Lam
			8,273,404 B2	9/2012	Dave et al.
			8,276,801 B2	10/2012	Zemlok et al.
			8,276,802 B2	10/2012	Kostrzewski
			8,281,973 B2	10/2012	Wenchell et al.

(56)

References Cited

U.S. PATENT DOCUMENTS

			8,377,044 B2	2/2013	Coe et al.	
			8,382,761 B2	2/2013	Holsten et al.	
			8,387,848 B2*	3/2013	Johnson	A61B 17/068 227/175.1
8,281,974 B2	10/2012	Hessler et al.	8,388,633 B2	3/2013	Rousseau et al.	
8,285,367 B2	10/2012	Hyde et al.	8,393,513 B2	3/2013	Jankowski	
8,286,845 B2	10/2012	Perry et al.	8,393,514 B2	3/2013	Shelton, IV et al.	
8,286,846 B2	10/2012	Smith et al.	8,393,516 B2	3/2013	Kostrzewski	
8,287,561 B2	10/2012	Nunez et al.	8,397,971 B2	3/2013	Yates et al.	
8,292,147 B2	10/2012	Viola	8,397,973 B1	3/2013	Hausen	
8,292,150 B2	10/2012	Bryant	8,398,633 B2	3/2013	Mueller	
8,292,151 B2	10/2012	Viola	8,398,673 B2	3/2013	Hinchliffe et al.	
8,292,152 B2	10/2012	Milliman et al.	8,403,138 B2	3/2013	Weisshaupt et al.	
8,292,155 B2	10/2012	Shelton, IV et al.	8,403,197 B2	3/2013	Vidal et al.	
8,292,157 B2	10/2012	Smith et al.	8,403,198 B2	3/2013	Sorrentino et al.	
8,292,888 B2	10/2012	Whitman	8,403,945 B2	3/2013	Whitfield et al.	
8,298,161 B2	10/2012	Vargas	8,403,950 B2	3/2013	Palmer et al.	
8,298,677 B2	10/2012	Wiesner et al.	8,408,439 B2	4/2013	Huang et al.	
8,302,323 B2	11/2012	Fortier et al.	8,408,442 B2	4/2013	Racenet et al.	
8,308,040 B2	11/2012	Huang et al.	8,409,079 B2	4/2013	Okamoto et al.	
8,308,042 B2	11/2012	Aranyi	8,409,174 B2	4/2013	Omori	
8,308,043 B2	11/2012	Bindra et al.	8,409,222 B2	4/2013	Whitfield et al.	
8,308,046 B2	11/2012	Prommersberger	8,409,223 B2	4/2013	Sorrentino et al.	
8,308,659 B2	11/2012	Scheibe et al.	8,413,870 B2	4/2013	Pastorelli et al.	
8,313,496 B2	11/2012	Sauer et al.	8,413,871 B2	4/2013	Racenet et al.	
8,313,509 B2	11/2012	Kostrzewski	8,413,872 B2	4/2013	Patel	
8,317,070 B2	11/2012	Hueil et al.	8,414,577 B2	4/2013	Boudreaux et al.	
8,317,071 B1	11/2012	Knodel	8,418,908 B1	4/2013	Beardsley	
8,317,074 B2	11/2012	Ortiz et al.	8,418,909 B2	4/2013	Kostrzewski	
8,317,790 B2	11/2012	Bell et al.	8,424,737 B2	4/2013	Scirica	
8,319,002 B2	11/2012	Daniels et al.	8,424,739 B2	4/2013	Racenet et al.	
8,322,455 B2	12/2012	Shelton, IV et al.	8,424,740 B2	4/2013	Shelton, IV et al.	
8,322,589 B2	12/2012	Boudreaux	8,424,741 B2	4/2013	McGuckin, Jr. et al.	
8,322,590 B2	12/2012	Patel et al.	8,425,600 B2	4/2013	Maxwell	
8,323,314 B2	12/2012	Blier	8,430,292 B2	4/2013	Patel et al.	
8,323,789 B2	12/2012	Rozhin et al.	8,430,892 B2	4/2013	Bindra et al.	
8,328,061 B2	12/2012	Kasvikis	8,430,898 B2	4/2013	Wiener et al.	
8,328,062 B2	12/2012	Viola	8,439,246 B1	5/2013	Knodel	
8,328,063 B2	12/2012	Milliman et al.	8,444,036 B2	5/2013	Shelton, IV	
8,328,064 B2	12/2012	Racenet et al.	8,444,549 B2	5/2013	Viola et al.	
8,328,802 B2	12/2012	Deville et al.	8,453,904 B2	6/2013	Eskaros et al.	
8,328,823 B2	12/2012	Aranyi et al.	8,453,906 B2	6/2013	Huang et al.	
8,333,313 B2	12/2012	Boudreaux et al.	8,453,907 B2	6/2013	Laurent et al.	
8,333,691 B2	12/2012	Schaaf	8,453,908 B2	6/2013	Bedi et al.	
8,333,764 B2	12/2012	Francischelli et al.	8,453,912 B2	6/2013	Mastri et al.	
8,336,753 B2	12/2012	Olson et al.	8,453,914 B2	6/2013	Laurent et al.	
8,336,754 B2	12/2012	Cappola et al.	8,454,628 B2	6/2013	Smith et al.	
8,342,377 B2	1/2013	Milliman et al.	8,454,640 B2	6/2013	Johnston et al.	
8,342,378 B2	1/2013	Marczyk et al.	8,457,757 B2	6/2013	Caulier et al.	
8,342,379 B2	1/2013	Whitman et al.	8,459,520 B2	6/2013	Giordano et al.	
8,348,123 B2	1/2013	Scirica et al.	8,459,525 B2	6/2013	Yates et al.	
8,348,125 B2	1/2013	Viola et al.	8,464,922 B2	6/2013	Marczyk	
8,348,126 B2	1/2013	Olson et al.	8,464,923 B2	6/2013	Shelton, IV	
8,348,127 B2	1/2013	Marczyk	8,464,924 B2	6/2013	Gresham et al.	
8,348,129 B2	1/2013	Bedi et al.	8,464,925 B2	6/2013	Hull et al.	
8,348,130 B2	1/2013	Shah et al.	8,465,502 B2	6/2013	Zergiebel	
8,348,131 B2	1/2013	Omaits et al.	8,469,973 B2	6/2013	Meade et al.	
8,348,972 B2	1/2013	Soltz et al.	8,470,355 B2	6/2013	Skalla et al.	
8,353,437 B2	1/2013	Boudreaux	8,474,677 B2	7/2013	Woodard, Jr. et al.	
8,353,438 B2	1/2013	Baxter, III et al.	8,475,453 B2	7/2013	Marczyk et al.	
8,353,439 B2	1/2013	Baxter, III et al.	8,475,454 B1	7/2013	Alshemari	
8,356,740 B1	1/2013	Knodel	8,475,474 B2	7/2013	Bombard et al.	
8,357,144 B2	1/2013	Whitman et al.	8,475,491 B2	7/2013	Milo	
8,360,296 B2	1/2013	Zingman	8,479,969 B2	7/2013	Shelton, IV	
8,360,297 B2	1/2013	Shelton, IV et al.	8,480,703 B2	7/2013	Nicholas et al.	
8,360,298 B2	1/2013	Farascioni et al.	8,485,412 B2	7/2013	Shelton, IV et al.	
8,360,299 B2	1/2013	Zemlok et al.	8,485,413 B2	7/2013	Scheib et al.	
8,361,501 B2	1/2013	DiTizio et al.	8,490,853 B2	7/2013	Criscuolo et al.	
8,365,973 B1	2/2013	White et al.	8,491,603 B2	7/2013	Yeung et al.	
8,365,975 B1	2/2013	Manoux et al.	8,496,153 B2	7/2013	Demmy et al.	
8,365,976 B2	2/2013	Hess et al.	8,496,156 B2	7/2013	Sniffin et al.	
8,366,559 B2	2/2013	Papenfuss et al.	8,496,683 B2	7/2013	Prommersberger et al.	
8,366,787 B2	2/2013	Brown et al.	8,499,992 B2	8/2013	Whitman et al.	
8,371,491 B2	2/2013	Huitema et al.	8,499,993 B2	8/2013	Shelton, IV et al.	
8,371,492 B2	2/2013	Aranyi et al.	8,500,762 B2	8/2013	Sholev et al.	
8,371,493 B2	2/2013	Aranyi et al.	8,506,555 B2	8/2013	Ruiz Morales	
8,372,094 B2	2/2013	Bettuchi et al.	8,506,557 B2	8/2013	Zemlok et al.	
8,376,865 B2	2/2013	Forster et al.	8,506,580 B2	8/2013	Zergiebel et al.	
8,377,029 B2	2/2013	Nagao et al.	8,506,581 B2	8/2013	Wingardner, III et al.	

(56)

References Cited

U.S. PATENT DOCUMENTS

8,512,359 B2	8/2013	Whitman et al.	8,636,736 B2	1/2014	Yates et al.
8,517,239 B2	8/2013	Scheib et al.	8,636,766 B2	1/2014	Milliman et al.
8,517,241 B2	8/2013	Nicholas et al.	8,640,788 B2	2/2014	Dachs, II et al.
8,517,243 B2	8/2013	Giordano et al.	8,646,674 B2	2/2014	Schulte et al.
8,517,244 B2	8/2013	Shelton, IV et al.	8,647,258 B2	2/2014	Aranyi et al.
8,521,273 B2	8/2013	Kliman	8,647,350 B2	2/2014	Mohan et al.
8,523,042 B2	9/2013	Masiakos et al.	8,652,120 B2	2/2014	Giordano et al.
8,523,043 B2	9/2013	Ullrich et al.	8,652,151 B2	2/2014	Lehman et al.
8,523,881 B2	9/2013	Cabiri et al.	8,657,174 B2	2/2014	Yates et al.
8,523,900 B2	9/2013	Jinno et al.	8,657,176 B2	2/2014	Shelton, IV et al.
8,529,588 B2	9/2013	Ahlberg et al.	8,657,177 B2	2/2014	Scirica et al.
8,529,600 B2	9/2013	Woodard, Jr. et al.	8,657,178 B2	2/2014	Hueil et al.
8,529,819 B2	9/2013	Ostapoff et al.	8,657,814 B2	2/2014	Werneth et al.
8,532,747 B2	9/2013	Nock et al.	8,662,370 B2	3/2014	Takei
8,534,528 B2	9/2013	Shelton, IV	8,663,192 B2	3/2014	Hester et al.
8,535,304 B2	9/2013	Sklar et al.	8,664,792 B2	3/2014	Rebsdorf
8,540,128 B2	9/2013	Shelton, IV et al.	8,668,129 B2	3/2014	Olson
8,540,129 B2	9/2013	Baxter, III et al.	8,668,130 B2	3/2014	Hess et al.
8,540,130 B2	9/2013	Moore et al.	8,672,206 B2	3/2014	Aranyi et al.
8,540,131 B2	9/2013	Swayze	8,672,207 B2	3/2014	Shelton, IV et al.
8,540,133 B2	9/2013	Bedi et al.	8,672,208 B2	3/2014	Hess et al.
8,540,733 B2	9/2013	Whitman et al.	8,672,951 B2	3/2014	Smith et al.
8,540,735 B2	9/2013	Mitelberg et al.	8,678,263 B2	3/2014	Viola
8,550,984 B2	10/2013	Takemoto	8,679,093 B2	3/2014	Farra
8,551,076 B2	10/2013	Duval et al.	8,679,137 B2	3/2014	Bauman et al.
8,556,151 B2	10/2013	Viola	8,679,154 B2	3/2014	Smith et al.
8,556,918 B2	10/2013	Bauman et al.	8,679,156 B2	3/2014	Smith et al.
8,556,935 B1	10/2013	Knodel et al.	8,679,454 B2	3/2014	Guire et al.
8,561,870 B2	10/2013	Baxter, III et al.	8,684,250 B2	4/2014	Bettuchi et al.
8,561,873 B2	10/2013	Ingmanson et al.	8,684,253 B2	4/2014	Giordano et al.
8,567,656 B2	10/2013	Shelton, IV et al.	8,685,020 B2	4/2014	Weizman et al.
8,568,425 B2	10/2013	Ross et al.	8,695,866 B2	4/2014	Leimbach et al.
8,573,459 B2	11/2013	Smith et al.	8,696,665 B2	4/2014	Hunt et al.
8,573,461 B2	11/2013	Shelton, IV et al.	8,701,958 B2	4/2014	Shelton, IV et al.
8,573,462 B2	11/2013	Smith et al.	8,701,959 B2	4/2014	Shah
8,573,465 B2	11/2013	Shelton, IV	8,701,960 B1	4/2014	Manoux et al.
8,574,263 B2	11/2013	Mueller	8,708,210 B2	4/2014	Zemlok et al.
8,579,176 B2	11/2013	Smith et al.	8,708,211 B2	4/2014	Zemlok et al.
8,579,178 B2	11/2013	Holsten et al.	8,708,213 B2	4/2014	Shelton, IV et al.
8,579,937 B2	11/2013	Gresham	8,714,429 B2	5/2014	Demmy
8,579,938 B2	11/2013	Heinrich et al.	8,715,226 B2	5/2014	Webster et al.
8,584,919 B2	11/2013	Hueil et al.	8,720,766 B2	5/2014	Hess et al.
8,585,721 B2	11/2013	Kirsch	8,721,630 B2	5/2014	Ortiz et al.
8,590,760 B2	11/2013	Cummins et al.	8,721,646 B2	5/2014	Fox
8,590,762 B2 *	11/2013	Hess A61B 17/07207 227/175.1	8,721,666 B2	5/2014	Schroeder et al.
8,590,764 B2	11/2013	Hartwick et al.	8,727,197 B2	5/2014	Hess et al.
8,596,515 B2	12/2013	Okoniewski	8,728,119 B2	5/2014	Cummins
8,602,287 B2	12/2013	Yates et al.	8,728,120 B2	5/2014	Blier
8,602,288 B2	12/2013	Shelton, IV et al.	8,733,612 B2	5/2014	Ma
8,603,135 B2	12/2013	Mueller	8,733,613 B2	5/2014	Huitema et al.
8,608,043 B2	12/2013	Scirica	8,733,614 B2	5/2014	Ross et al.
8,608,044 B2	12/2013	Hueil et al.	8,734,478 B2	5/2014	Widenhouse et al.
8,608,045 B2	12/2013	Smith et al.	D706,927 S	6/2014	Cheney et al.
8,608,046 B2	12/2013	Laurent et al.	8,740,034 B2	6/2014	Morgan et al.
8,608,745 B2	12/2013	Guzman et al.	8,740,037 B2	6/2014	Shelton, IV et al.
8,613,383 B2	12/2013	Beckman et al.	8,740,038 B2	6/2014	Shelton, IV et al.
8,613,384 B2	12/2013	Pastorelli et al.	8,746,529 B2	6/2014	Shelton, IV et al.
8,616,431 B2	12/2013	Timm et al.	8,746,530 B2	6/2014	Giordano et al.
8,622,274 B2	1/2014	Yates et al.	8,746,533 B2	6/2014	Whitman et al.
8,622,275 B2	1/2014	Baxter, III et al.	8,746,535 B2	6/2014	Shelton, IV et al.
8,627,993 B2	1/2014	Smith et al.	8,747,238 B2	6/2014	Shelton, IV et al.
8,627,995 B2	1/2014	Smith et al.	8,752,264 B2	6/2014	Ackley et al.
8,628,518 B2	1/2014	Blumenkranz et al.	8,752,699 B2	6/2014	Morgan et al.
8,628,544 B2	1/2014	Farascioni	8,752,747 B2	6/2014	Shelton, IV et al.
8,631,987 B2	1/2014	Shelton, IV et al.	8,752,749 B2	6/2014	Moore et al.
8,631,992 B1	1/2014	Hausen et al.	8,757,287 B2	6/2014	Mak et al.
8,631,993 B2	1/2014	Kostrzewski	8,757,465 B2	6/2014	Woodard, Jr. et al.
8,632,462 B2	1/2014	Yoo et al.	8,757,467 B2	6/2014	Racenet et al.
8,632,525 B2	1/2014	Kerr et al.	8,758,235 B2	6/2014	Jaworek
8,632,535 B2	1/2014	Shelton, IV et al.	8,758,366 B2	6/2014	McLean et al.
8,632,563 B2	1/2014	Nagase et al.	8,758,391 B2	6/2014	Swayze et al.
8,636,187 B2	1/2014	Hueil et al.	8,758,438 B2	6/2014	Boyce et al.
8,636,191 B2	1/2014	Meagher	8,763,875 B2	7/2014	Morgan et al.
8,636,193 B2	1/2014	Whitman et al.	8,763,877 B2	7/2014	Schall et al.
			8,763,879 B2	7/2014	Shelton, IV et al.
			8,770,458 B2	7/2014	Scirica
			8,770,459 B2	7/2014	Racenet et al.
			8,770,460 B2	7/2014	Belzer
			8,771,169 B2	7/2014	Whitman et al.

(56)

References Cited

U.S. PATENT DOCUMENTS

8,771,312 B1	7/2014	Knodel et al.	8,920,435 B2	12/2014	Smith et al.
8,777,004 B2	7/2014	Shelton, IV et al.	8,920,438 B2	12/2014	Aranyi et al.
8,783,541 B2	7/2014	Shelton, IV et al.	8,920,443 B2	12/2014	Hiles et al.
8,783,542 B2	7/2014	Riestenberg et al.	8,920,444 B2	12/2014	Hiles et al.
8,783,543 B2	7/2014	Shelton, IV et al.	8,925,782 B2	1/2015	Shelton, IV
8,784,304 B2	7/2014	Mikkaichi et al.	8,925,783 B2	1/2015	Zemlok et al.
8,784,404 B2	7/2014	Doyle et al.	8,925,788 B2	1/2015	Hess et al.
8,784,415 B2	7/2014	Malackowski et al.	8,926,598 B2	1/2015	Mollere et al.
8,789,737 B2	7/2014	Hodgkinson et al.	8,931,682 B2	1/2015	Timm et al.
8,789,739 B2	7/2014	Swensgard	8,936,614 B2	1/2015	Allen, IV
8,789,740 B2	7/2014	Baxter, III et al.	8,939,343 B2	1/2015	Milliman et al.
8,789,741 B2	7/2014	Baxter, III et al.	8,939,344 B2	1/2015	Olson et al.
8,790,684 B2	7/2014	Dave et al.	8,939,974 B2	1/2015	Boudreaux et al.
8,794,496 B2	8/2014	Scirica	8,945,163 B2	2/2015	Voegele et al.
8,794,497 B2	8/2014	Zingman	8,955,732 B2	2/2015	Zemlok et al.
8,795,276 B2	8/2014	Dietz et al.	8,956,390 B2	2/2015	Shah et al.
8,795,308 B2	8/2014	Valin	8,960,519 B2	2/2015	Whitman et al.
8,800,837 B2	8/2014	Zemlok	8,960,520 B2	2/2015	McCuen
8,800,838 B2	8/2014	Shelton, IV	8,960,521 B2	2/2015	Kostrzewski
8,800,840 B2	8/2014	Jankowski	8,967,443 B2	3/2015	McCuen
8,800,841 B2	8/2014	Ellerhorst et al.	8,967,446 B2	3/2015	Beardsley et al.
8,801,732 B2	8/2014	Harris et al.	8,967,448 B2	3/2015	Carter et al.
8,801,734 B2	8/2014	Shelton, IV et al.	8,968,276 B2	3/2015	Zemlok et al.
8,801,735 B2	8/2014	Shelton, IV et al.	8,968,337 B2	3/2015	Whitfield et al.
8,801,752 B2	8/2014	Fortier et al.	8,968,355 B2	3/2015	Malkowski et al.
8,806,973 B2	8/2014	Ross et al.	8,968,358 B2	3/2015	Reschke
8,808,294 B2	8/2014	Fox et al.	8,973,803 B2	3/2015	Hall et al.
8,808,311 B2	8/2014	Heinrich et al.	8,973,804 B2	3/2015	Hess et al.
8,808,325 B2	8/2014	Hess et al.	8,974,440 B2	3/2015	Farritor et al.
8,814,024 B2	8/2014	Woodard, Jr. et al.	8,978,954 B2	3/2015	Shelton, IV et al.
8,814,025 B2	8/2014	Miller et al.	8,978,955 B2	3/2015	Aronhalt et al.
8,820,603 B2	9/2014	Shelton, IV et al.	8,978,956 B2	3/2015	Schall et al.
8,820,605 B2	9/2014	Shelton, IV	8,979,890 B2	3/2015	Boudreaux
8,820,606 B2	9/2014	Hodgkinson	8,982,195 B2	3/2015	Claus et al.
8,827,133 B2	9/2014	Shelton, IV et al.	8,985,428 B2	3/2015	Natarajan et al.
8,827,134 B2	9/2014	Viola et al.	8,991,676 B2	3/2015	Hess et al.
8,827,903 B2	9/2014	Shelton, IV et al.	8,991,677 B2	3/2015	Moore et al.
8,833,632 B2	9/2014	Swensgard	8,991,678 B2	3/2015	Wellman et al.
8,834,498 B2	9/2014	Byrum et al.	8,992,422 B2	3/2015	Spivey et al.
8,834,518 B2	9/2014	Faller et al.	8,996,165 B2	3/2015	Wang et al.
8,840,003 B2	9/2014	Morgan et al.	8,998,058 B2	4/2015	Moore et al.
8,840,603 B2	9/2014	Shelton, IV et al.	8,998,059 B2	4/2015	Smith et al.
8,840,609 B2	9/2014	Stuebe	8,998,061 B2	4/2015	Williams et al.
8,844,789 B2	9/2014	Shelton, IV et al.	8,998,935 B2	4/2015	Hart
8,851,354 B2	10/2014	Swensgard et al.	9,004,339 B1	4/2015	Park
8,852,185 B2	10/2014	Twomey	9,005,230 B2	4/2015	Yates et al.
8,852,199 B2	10/2014	Deslauriers et al.	9,005,238 B2	4/2015	DeSantis et al.
8,857,693 B2	10/2014	Schuckmann et al.	9,005,243 B2	4/2015	Stopek et al.
8,857,694 B2	10/2014	Shelton, IV et al.	9,010,608 B2	4/2015	Casasanta, Jr. et al.
8,858,538 B2	10/2014	Belson et al.	9,016,540 B2	4/2015	Whitman et al.
8,858,571 B2	10/2014	Shelton, IV et al.	9,016,541 B2	4/2015	Viola et al.
8,858,590 B2	10/2014	Shelton, IV et al.	9,016,542 B2	4/2015	Shelton, IV et al.
8,864,007 B2	10/2014	Widenhouse et al.	9,017,331 B2	4/2015	Fox
8,864,009 B2	10/2014	Shelton, IV et al.	9,023,014 B2	5/2015	Chowaniec et al.
8,870,049 B2	10/2014	Amid et al.	9,027,817 B2	5/2015	Milliman et al.
8,870,050 B2	10/2014	Hodgkinson	9,028,494 B2	5/2015	Shelton, IV et al.
8,870,912 B2	10/2014	Brisson et al.	9,028,495 B2	5/2015	Mueller et al.
8,875,971 B2	11/2014	Hall et al.	9,028,519 B2	5/2015	Yates et al.
8,875,972 B2	11/2014	Weisenburgh, II et al.	9,033,203 B2	5/2015	Woodard, Jr. et al.
8,876,857 B2	11/2014	Burbank	9,033,204 B2	5/2015	Shelton, IV et al.
8,876,858 B2	11/2014	Braun	9,038,881 B1	5/2015	Schaller et al.
8,888,792 B2	11/2014	Harris et al.	9,044,227 B2	6/2015	Shelton, IV et al.
8,893,946 B2	11/2014	Boudreaux et al.	9,044,228 B2	6/2015	Woodard, Jr. et al.
8,893,949 B2	11/2014	Shelton, IV et al.	9,044,229 B2	6/2015	Scheib et al.
8,894,647 B2	11/2014	Beardsley et al.	9,044,230 B2	6/2015	Morgan et al.
8,899,462 B2	12/2014	Kostrzewski et al.	9,050,083 B2	6/2015	Yates et al.
8,899,463 B2	12/2014	Schall et al.	9,050,084 B2	6/2015	Schmid et al.
8,899,464 B2	12/2014	Hueil et al.	9,050,120 B2	6/2015	Swarup et al.
8,899,465 B2	12/2014	Shelton, IV et al.	9,055,941 B2	6/2015	Schmid et al.
8,899,466 B2	12/2014	Baxter, III et al.	9,055,942 B2	6/2015	Balbierz et al.
8,905,287 B2	12/2014	Racenet et al.	9,055,943 B2	6/2015	Zemlok et al.
8,905,977 B2	12/2014	Shelton et al.	9,055,944 B2	6/2015	Hodgkinson et al.
8,911,426 B2	12/2014	Coppeta et al.	9,060,769 B2	6/2015	Coleman et al.
8,911,471 B2	12/2014	Spivey et al.	9,060,770 B2	6/2015	Shelton, IV et al.
8,920,433 B2	12/2014	Barrier et al.	9,060,894 B2	6/2015	Wubbeling
			9,072,515 B2	7/2015	Hall et al.
			9,072,523 B2	7/2015	Houser et al.
			9,072,535 B2	7/2015	Shelton, IV et al.
			9,072,536 B2	7/2015	Shelton, IV et al.

(56)

References Cited

U.S. PATENT DOCUMENTS

9,078,653 B2	7/2015	Leimbach et al.	9,277,922 B2	3/2016	Carter et al.
9,084,601 B2	7/2015	Moore et al.	9,282,962 B2	3/2016	Schmid et al.
9,084,602 B2	7/2015	Gleiman	9,282,963 B2	3/2016	Bryant
9,089,326 B2	7/2015	Krumanaker et al.	9,282,966 B2	3/2016	Shelton, IV et al.
9,089,330 B2	7/2015	Widenhouse et al.	9,282,974 B2	3/2016	Shelton, IV
9,089,352 B2	7/2015	Jeong	9,283,054 B2	3/2016	Morgan et al.
9,095,339 B2	8/2015	Moore et al.	9,289,206 B2	3/2016	Hess et al.
9,095,362 B2	8/2015	Dachs, II et al.	9,289,207 B2	3/2016	Shelton, IV
9,096,033 B2	8/2015	Holop et al.	9,289,210 B2	3/2016	Baxter, III et al.
9,101,358 B2	8/2015	Kerr et al.	9,289,212 B2	3/2016	Shelton, IV et al.
9,101,385 B2	8/2015	Shelton, IV et al.	9,289,225 B2	3/2016	Shelton, IV et al.
9,107,663 B2	8/2015	Swensgard	9,289,256 B2	3/2016	Shelton, IV et al.
9,110,587 B2	8/2015	Kim et al.	9,295,464 B2	3/2016	Shelton, IV et al.
9,113,862 B2	8/2015	Morgan et al.	9,295,466 B2	3/2016	Hodgkinson et al.
9,113,864 B2	8/2015	Morgan et al.	9,301,752 B2	4/2016	Vasudevan et al.
9,113,865 B2	8/2015	Shelton, IV et al.	9,301,753 B2	4/2016	Aldridge et al.
9,113,870 B2	8/2015	Viola	9,301,755 B2	4/2016	Shelton, IV et al.
9,113,874 B2	8/2015	Shelton, IV et al.	9,301,759 B2	4/2016	Spivey et al.
9,113,880 B2	8/2015	Zemlok et al.	9,307,965 B2	4/2016	Ming et al.
9,113,881 B2	8/2015	Scirica	9,307,986 B2	4/2016	Hall et al.
9,113,883 B2	8/2015	Aronhalt et al.	9,307,987 B2	4/2016	Swensgard et al.
9,113,884 B2	8/2015	Shelton, IV et al.	9,307,988 B2	4/2016	Shelton, IV
9,119,657 B2	9/2015	Shelton, IV et al.	9,307,989 B2	4/2016	Shelton, IV et al.
9,119,898 B2	9/2015	Bayon et al.	9,307,994 B2	4/2016	Gresham et al.
9,119,957 B2	9/2015	Gantz et al.	9,308,009 B2	4/2016	Madan et al.
9,123,286 B2	9/2015	Park	9,314,246 B2	4/2016	Shelton, IV et al.
9,125,649 B2	9/2015	Bruewer et al.	9,314,247 B2	4/2016	Shelton, IV et al.
9,125,654 B2	9/2015	Aronhalt et al.	9,314,594 B2	4/2016	Kirschenman
9,125,662 B2	9/2015	Shelton, IV	9,320,518 B2	4/2016	Henderson et al.
9,131,940 B2	9/2015	Huitema et al.	9,320,520 B2	4/2016	Shelton, IV et al.
9,138,225 B2	9/2015	Huang et al.	9,320,521 B2	4/2016	Shelton, IV et al.
9,138,226 B2	9/2015	Racenet et al.	9,320,523 B2	4/2016	Shelton, IV et al.
9,149,274 B2	10/2015	Spivey et al.	9,326,767 B2	5/2016	Koch et al.
9,149,324 B2	10/2015	Huang et al.	9,326,768 B2	5/2016	Shelton, IV
9,149,325 B2	10/2015	Worrell et al.	9,326,769 B2	5/2016	Shelton, IV et al.
9,168,038 B2	10/2015	Shelton, IV et al.	9,326,770 B2	5/2016	Shelton, IV et al.
9,168,039 B1	10/2015	Knodel	9,326,771 B2	5/2016	Baxter, III et al.
9,179,911 B2	11/2015	Morgan et al.	9,326,771 B2	5/2016	Henderson et al.
9,179,912 B2	11/2015	Yates et al.	9,332,974 B2	5/2016	Weaner et al.
9,186,046 B2	11/2015	Ramamurthy et al.	9,332,984 B2	5/2016	Leimbach et al.
9,186,137 B2	11/2015	Farascioni et al.	9,332,987 B2	5/2016	Wei et al.
9,186,140 B2	11/2015	Hiles et al.	9,333,082 B2	5/2016	Anim et al.
9,186,143 B2	11/2015	Timm et al.	9,345,477 B2	5/2016	Hall et al.
9,192,380 B2	11/2015	Racenet et al.	9,345,481 B2	5/2016	Leimbach et al.
9,192,384 B2	11/2015	Bettuchi	9,351,726 B2	5/2016	Leimbach et al.
9,198,661 B2	12/2015	Swensgard	9,351,727 B2	5/2016	Schmid et al.
9,198,662 B2	12/2015	Barton et al.	9,351,730 B2	5/2016	Carter et al.
9,204,830 B2	12/2015	Zand et al.	9,351,731 B2	6/2016	Hall et al.
9,204,877 B2	12/2015	Whitman et al.	9,358,003 B2	6/2016	Shelton, IV et al.
9,204,878 B2	12/2015	Hall et al.	9,358,005 B2	6/2016	Sorrentino et al.
9,204,879 B2	12/2015	Shelton, IV	9,358,015 B2	6/2016	Kostrzewski et al.
9,204,880 B2	12/2015	Baxter, III et al.	9,364,217 B2	6/2016	Olson et al.
9,204,923 B2	12/2015	Manzo et al.	9,364,219 B2	6/2016	Williams
9,211,120 B2	12/2015	Scheib et al.	9,364,220 B2	6/2016	D'Agostino et al.
9,211,121 B2	12/2015	Hall et al.	9,364,229 B2	6/2016	Shelton, IV et al.
9,211,122 B2	12/2015	Hagerty et al.	9,364,230 B2	6/2016	Alexander, III et al.
9,216,019 B2	12/2015	Schmid et al.	9,364,233 B2	6/2016	Ceniccola et al.
9,216,062 B2	12/2015	Duque et al.	9,370,341 B2	6/2016	Shelton, IV et al.
9,220,500 B2	12/2015	Swayze et al.	9,370,358 B2	6/2016	Smith et al.
9,220,501 B2	12/2015	Baxter, III et al.	9,370,364 B2	7/2016	Swensgard et al.
9,220,502 B2	12/2015	Zemlok et al.	9,386,983 B2	7/2016	Aronhalt et al.
9,220,559 B2	12/2015	Worrell et al.	9,386,984 B2	7/2016	Koch, Jr. et al.
9,226,751 B2	1/2016	Shelton, IV et al.	9,386,985 B2	7/2016	Baxter, III et al.
9,232,941 B2	1/2016	Vasudevan et al.	9,386,988 B2	7/2016	Laurent et al.
9,232,945 B2	1/2016	Zingman	9,393,015 B2	7/2016	Wang et al.
9,237,891 B2	1/2016	Shelton, IV	9,393,018 B2	7/2016	Auld
9,237,892 B2	1/2016	Hodgkinson	9,398,911 B2	8/2016	Williams et al.
9,241,714 B2	1/2016	Timm et al.	9,402,604 B2	8/2016	Ortiz et al.
9,241,758 B2	1/2016	Franer et al.	9,402,626 B2	8/2016	Beardsley
9,254,131 B2	2/2016	Soltz et al.	9,402,628 B2	8/2016	Shelton, IV et al.
9,265,500 B2	2/2016	Sorrentino et al.	9,408,604 B2	8/2016	Shelton, IV
9,271,753 B2	3/2016	Butler et al.	9,408,606 B2	8/2016	Stulen et al.
9,271,799 B2	3/2016	Shelton, IV et al.	9,408,622 B2	8/2016	Shelton, IV et al.
9,272,406 B2	3/2016	Aronhalt et al.	9,414,838 B2	8/2016	Edwards et al.
9,277,919 B2 *	3/2016	Timmer A61B 17/072	9,414,848 B2	8/2016	Monson et al.
			9,414,880 B2	8/2016	Patel et al.
			9,421,013 B2	8/2016	Ingmanson et al.
			9,421,014 B2	8/2016	Park et al.
			9,427,223 B2	8/2016	Gupta et al.
			9,427,232 B2	8/2016	

(56)

References Cited

U.S. PATENT DOCUMENTS

9,433,411 B2	9/2016	Racenet et al.	9,655,615 B2	5/2017	Knodel et al.
9,433,419 B2	9/2016	Gonzalez et al.	9,655,624 B2	5/2017	Shelton, IV et al.
9,433,420 B2	9/2016	Hodgkinson	9,656,024 B2	5/2017	Eggert et al.
9,439,649 B2	9/2016	Shelton, IV et al.	9,662,110 B2	5/2017	Huang et al.
9,439,651 B2	9/2016	Smith et al.	9,662,131 B2	5/2017	Omori et al.
9,445,808 B2	9/2016	Woodard, Jr. et al.	9,668,729 B2	6/2017	Williams et al.
9,445,813 B2	9/2016	Shelton, IV et al.	9,668,732 B2	6/2017	Patel et al.
9,451,956 B2	9/2016	Balbierz et al.	9,675,344 B2	6/2017	Combrowski et al.
9,451,958 B2	9/2016	Shelton, IV et al.	9,675,351 B2	6/2017	Hodgkinson et al.
9,463,260 B2	10/2016	Stopek	9,675,355 B2	6/2017	Shelton, IV et al.
9,468,438 B2	10/2016	Baber et al.	9,675,372 B2	6/2017	Laurent et al.
9,480,476 B2	11/2016	Aldridge et al.	9,675,375 B2	6/2017	Houser et al.
9,480,492 B2	11/2016	Aranyi et al.	9,681,870 B2	6/2017	Baxter, III et al.
9,486,213 B2	11/2016	Altman et al.	9,681,873 B2	6/2017	Smith et al.
9,486,214 B2	11/2016	Shelton, IV	9,687,230 B2	6/2017	Leimbach et al.
9,486,302 B2	11/2016	Boey et al.	9,687,231 B2	6/2017	Baxter, III et al.
9,492,146 B2	11/2016	Kostrzewski et al.	9,687,232 B2*	6/2017	Shelton, IV A61B 17/07207
9,492,167 B2	11/2016	Shelton, IV et al.	9,687,236 B2	6/2017	Leimbach et al.
9,492,170 B2	11/2016	Bear et al.	9,687,237 B2	6/2017	Schmid et al.
9,492,189 B2	11/2016	Williams et al.	9,690,362 B2	6/2017	Leimbach et al.
9,498,211 B2	11/2016	Cohn et al.	9,693,772 B2	7/2017	Ingmanson et al.
9,498,215 B2	11/2016	Duque et al.	9,693,777 B2	7/2017	Schellin et al.
9,498,219 B2	11/2016	Moore et al.	9,693,819 B2	7/2017	Francischelli et al.
D775,336 S	12/2016	Shelton, IV et al.	9,700,309 B2	7/2017	Jaworek et al.
9,510,827 B2	12/2016	Kostrzewski	9,700,310 B2	7/2017	Morgan et al.
9,510,828 B2	12/2016	Yates et al.	9,700,312 B2	7/2017	Kostrzewski et al.
9,510,830 B2	12/2016	Shelton, IV et al.	9,700,317 B2	7/2017	Aronhalt et al.
9,510,846 B2	12/2016	Sholev et al.	9,700,319 B2	7/2017	Motooka et al.
9,510,925 B2	12/2016	Hotter et al.	9,700,321 B2	7/2017	Shelton, IV et al.
9,517,063 B2	12/2016	Swayze et al.	9,706,991 B2	7/2017	Hess et al.
9,517,068 B2	12/2016	Shelton, IV et al.	9,706,993 B2	7/2017	Hessler et al.
9,522,029 B2	12/2016	Yates et al.	9,707,043 B2	7/2017	Bozung
9,539,020 B2	1/2017	Conlon et al.	9,724,091 B2	8/2017	Shelton, IV et al.
9,545,258 B2	1/2017	Smith et al.	9,724,092 B2	8/2017	Baxter, III et al.
9,549,732 B2	1/2017	Yates et al.	9,724,094 B2	8/2017	Baber et al.
9,549,735 B2	1/2017	Shelton, IV et al.	9,724,096 B2	8/2017	Thompson et al.
9,554,794 B2	1/2017	Baber et al.	9,724,098 B2	8/2017	Baxter, III et al.
9,554,796 B2	1/2017	Kostrzewski	9,730,692 B2	8/2017	Shelton, IV et al.
9,561,032 B2	2/2017	Shelton, IV et al.	9,730,695 B2	8/2017	Leimbach et al.
9,561,038 B2	2/2017	Shelton, IV et al.	9,730,697 B2	8/2017	Morgan et al.
9,561,045 B2	2/2017	Hinman et al.	9,733,663 B2	8/2017	Leimbach et al.
9,566,061 B2	2/2017	Aronhalt et al.	9,737,301 B2	8/2017	Baber et al.
9,572,574 B2	2/2017	Shelton, IV et al.	9,737,302 B2	8/2017	Shelton, IV et al.
9,572,577 B2	2/2017	Lloyd et al.	9,737,303 B2	8/2017	Shelton, IV et al.
9,574,644 B2	2/2017	Parihar	9,737,365 B2	8/2017	Hegeman et al.
9,585,657 B2	3/2017	Shelton, IV et al.	9,743,928 B2	8/2017	Shelton, IV et al.
9,585,658 B2	3/2017	Shelton, IV	9,743,929 B2	8/2017	Leimbach et al.
9,585,660 B2	3/2017	Laurent et al.	9,750,498 B2	9/2017	Timm et al.
9,585,662 B2	3/2017	Shelton, IV et al.	9,750,499 B2	9/2017	Leimbach et al.
9,585,663 B2	3/2017	Shelton, IV et al.	9,750,501 B2	9/2017	Shelton, IV et al.
9,592,050 B2	3/2017	Schmid et al.	9,750,502 B2	9/2017	Scirica et al.
9,592,052 B2	3/2017	Shelton, IV	9,757,123 B2	9/2017	Giordano et al.
9,592,053 B2	3/2017	Shelton, IV et al.	9,757,124 B2	9/2017	Schellin et al.
9,592,054 B2	3/2017	Schmid et al.	9,757,126 B2	9/2017	Cappola
9,597,073 B2	3/2017	Sorrentino et al.	9,757,128 B2	9/2017	Baber et al.
9,597,074 B2	3/2017	Felder et al.	9,757,130 B2	9/2017	Shelton, IV
9,597,075 B2	3/2017	Shelton, IV et al.	9,763,662 B2	9/2017	Shelton, IV et al.
9,597,080 B2	3/2017	Milliman et al.	9,770,245 B2	9/2017	Swayze et al.
9,597,104 B2	3/2017	Nicholas et al.	9,770,317 B2	9/2017	Nering
9,603,595 B2	3/2017	Shelton, IV et al.	9,775,608 B2	10/2017	Aronhalt et al.
9,603,598 B2	3/2017	Shelton, IV et al.	9,775,609 B2	10/2017	Shelton, IV et al.
9,603,991 B2	3/2017	Shelton, IV et al.	9,775,613 B2	10/2017	Shelton, IV et al.
9,610,080 B2	4/2017	Whitfield et al.	9,775,614 B2	10/2017	Shelton, IV et al.
9,615,826 B2	4/2017	Shelton, IV et al.	9,782,169 B2	10/2017	Kimsey et al.
9,629,623 B2	4/2017	Lytle, IV et al.	9,788,834 B2	10/2017	Schmid et al.
9,629,626 B2	4/2017	Soltz et al.	9,788,836 B2	10/2017	Overmyer et al.
9,629,629 B2	4/2017	Leimbach et al.	9,795,379 B2	10/2017	Leimbach et al.
9,629,814 B2	4/2017	Widenhouse et al.	9,795,381 B2	10/2017	Shelton, IV
9,636,113 B2	5/2017	Wenchell	9,795,382 B2	10/2017	Shelton, IV
9,642,620 B2	5/2017	Baxter, III et al.	9,795,384 B2	10/2017	Weaner et al.
9,649,096 B2	5/2017	Sholev	9,801,626 B2	10/2017	Parihar et al.
9,649,110 B2	5/2017	Parihar et al.	9,801,627 B2	10/2017	Harris et al.
9,649,111 B2	5/2017	Shelton, IV et al.	9,801,628 B2	10/2017	Harris et al.
9,655,613 B2	5/2017	Schaller	9,801,634 B2	10/2017	Shelton, IV et al.
9,655,614 B2	5/2017	Swensgard et al.	9,804,618 B2	10/2017	Leimbach et al.
			9,808,244 B2	11/2017	Leimbach et al.
			9,808,246 B2	11/2017	Shelton, IV et al.
			9,808,247 B2	11/2017	Shelton, IV et al.
			9,808,249 B2	11/2017	Shelton, IV

(56)

References Cited

U.S. PATENT DOCUMENTS

9,814,460 B2	11/2017	Kimsey et al.	9,968,356 B2	5/2018	Shelton, IV et al.
9,814,462 B2	11/2017	Woodard, Jr. et al.	9,968,397 B2	5/2018	Taylor et al.
9,820,738 B2	11/2017	Lytile, IV et al.	9,974,529 B2	5/2018	Shelton, IV et al.
9,820,741 B2	11/2017	Kostrzewski	9,974,538 B2	5/2018	Baxter, III et al.
9,820,770 B2	11/2017	Palermo	9,980,630 B2	5/2018	Larkin et al.
9,826,976 B2	11/2017	Parihar et al.	9,980,713 B2	5/2018	Aronhalt et al.
9,826,977 B2	11/2017	Leimbach et al.	9,980,729 B2	5/2018	Moore et al.
9,826,978 B2	11/2017	Shelton, IV et al.	9,987,000 B2	6/2018	Shelton, IV et al.
9,833,236 B2	12/2017	Shelton, IV et al.	9,987,006 B2	6/2018	Morgan et al.
9,833,238 B2	12/2017	Baxter, III et al.	9,987,011 B2	6/2018	Williams et al.
9,833,241 B2	12/2017	Huitema et al.	9,987,012 B2	6/2018	Shah
9,833,242 B2	12/2017	Baxter, III et al.	9,987,095 B2	6/2018	Chowaniec et al.
9,839,420 B2	12/2017	Shelton, IV et al.	9,987,099 B2	6/2018	Chen et al.
9,839,421 B2	12/2017	Zerkle et al.	9,993,248 B2	6/2018	Shelton, IV et al.
9,839,422 B2	12/2017	Schellin et al.	9,993,258 B2	6/2018	Shelton, IV et al.
9,839,423 B2	12/2017	Vendely et al.	9,999,408 B2	6/2018	Boudreaux et al.
9,839,425 B2	12/2017	Zergiebel et al.	9,999,426 B2	6/2018	Moore et al.
9,839,427 B2	12/2017	Swayze et al.	9,999,431 B2	6/2018	Shelton, IV et al.
9,839,428 B2	12/2017	Baxter, III et al.	10,004,497 B2	6/2018	Overmyer et al.
9,839,429 B2	12/2017	Weisenburgh, II et al.	10,004,498 B2	6/2018	Morgan et al.
9,839,480 B2	12/2017	Pribanic et al.	10,004,501 B2	6/2018	Shelton, IV et al.
9,844,368 B2	12/2017	Boudreaux et al.	10,004,505 B2	6/2018	Moore et al.
9,844,369 B2	12/2017	Huitema et al.	D822,206 S	7/2018	Shelton, IV et al.
9,844,372 B2	12/2017	Shelton, IV et al.	10,010,322 B2	7/2018	Shelton, IV et al.
9,844,373 B2	12/2017	Swayze et al.	10,010,324 B2	7/2018	Huitema et al.
9,844,374 B2	12/2017	Lytile, IV et al.	10,013,049 B2	7/2018	Leimbach et al.
9,844,375 B2	12/2017	Overmyer et al.	10,016,199 B2	7/2018	Baber et al.
9,844,376 B2	12/2017	Baxter, III et al.	10,028,742 B2	7/2018	Shelton, IV et al.
9,844,379 B2	12/2017	Shelton, IV et al.	10,028,743 B2	7/2018	Shelton, IV et al.
9,848,873 B2	12/2017	Shelton, IV	10,028,744 B2	7/2018	Shelton, IV et al.
9,848,875 B2	12/2017	Aronhalt et al.	10,028,761 B2	7/2018	Leimbach et al.
9,848,898 B2	12/2017	Friedman et al.	D826,405 S	8/2018	Shelton, IV et al.
9,855,040 B2	1/2018	Kostrzewski	10,039,529 B2	8/2018	Kerr et al.
9,855,041 B2	1/2018	Nering et al.	10,045,769 B2	8/2018	Aronhalt et al.
9,861,359 B2	1/2018	Shelton, IV et al.	10,045,776 B2	8/2018	Shelton, IV et al.
9,861,361 B2	1/2018	Aronhalt et al.	10,045,779 B2	8/2018	Savage et al.
9,867,612 B2	1/2018	Parihar et al.	10,045,781 B2	8/2018	Cropper et al.
9,867,613 B2	1/2018	Marczyk et al.	10,052,044 B2	8/2018	Shelton, IV et al.
9,867,616 B2	1/2018	Marczyk	10,052,099 B2	8/2018	Morgan et al.
9,867,618 B2	1/2018	Hall et al.	10,052,100 B2	8/2018	Morgan et al.
9,868,198 B2	1/2018	Nicholas et al.	10,052,102 B2	8/2018	Baxter, III et al.
9,872,682 B2	1/2018	Hess et al.	10,058,317 B2	8/2018	Fan et al.
9,872,683 B2	1/2018	Hopkins et al.	10,058,327 B2	8/2018	Weisenburgh, II et al.
9,872,684 B2	1/2018	Hall et al.	10,058,963 B2	8/2018	Shelton, IV et al.
9,877,721 B2	1/2018	Schellin et al.	10,064,618 B2	9/2018	Allen
9,883,860 B2	2/2018	Leimbach	10,064,621 B2	9/2018	Kerr et al.
9,883,861 B2	2/2018	Shelton, IV et al.	10,064,624 B2	9/2018	Shelton, IV et al.
9,884,456 B2 *	2/2018	Schellin A61B 17/068	10,064,688 B2	9/2018	Shelton, IV et al.
9,888,919 B2	2/2018	Leimbach et al.	10,070,861 B2	9/2018	Spivey et al.
9,888,924 B2	2/2018	Ebersole et al.	10,070,863 B2	9/2018	Swayze et al.
9,889,230 B2	2/2018	Bennett et al.	10,071,452 B2	9/2018	Shelton, IV et al.
9,895,147 B2	2/2018	Shelton, IV	10,076,325 B2	9/2018	Huang et al.
9,895,148 B2	2/2018	Shelton, IV et al.	10,080,552 B2	9/2018	Nicholas et al.
9,895,813 B2	2/2018	Blumenkranz et al.	D831,209 S *	10/2018	Huitema D24/145
9,901,342 B2	2/2018	Shelton, IV et al.	10,085,748 B2	10/2018	Morgan et al.
9,901,343 B2	2/2018	Vold et al.	10,085,749 B2	10/2018	Cappola et al.
9,907,620 B2	3/2018	Shelton, IV et al.	10,085,806 B2	10/2018	Hagn et al.
9,913,642 B2	3/2018	Leimbach et al.	10,092,292 B2	10/2018	Boudreaux et al.
9,913,647 B2	3/2018	Weisenburgh, II et al.	10,111,679 B2	10/2018	Baber et al.
9,913,648 B2	3/2018	Shelton, IV et al.	10,117,649 B2	11/2018	Baxter et al.
9,913,694 B2	3/2018	Brisson	10,117,652 B2	11/2018	Schmid et al.
9,918,704 B2	3/2018	Shelton, IV et al.	10,123,798 B2	11/2018	Baxter, III et al.
9,918,716 B2	3/2018	Baxter, III et al.	10,123,799 B2	11/2018	Zergiebel et al.
9,918,717 B2	3/2018	Czernik	10,130,352 B2	11/2018	Widenhouse et al.
9,918,778 B2	3/2018	Walberg et al.	10,130,359 B2	11/2018	Hess et al.
9,924,942 B2	3/2018	Swayze et al.	10,130,363 B2	11/2018	Huitema et al.
9,924,947 B2	3/2018	Shelton, IV et al.	10,130,366 B2	11/2018	Shelton, IV et al.
9,924,961 B2	3/2018	Shelton, IV et al.	10,135,242 B2	11/2018	Baber et al.
9,931,118 B2	4/2018	Shelton, IV et al.	10,136,887 B2	11/2018	Shelton, IV et al.
9,943,309 B2	4/2018	Shelton, IV et al.	10,136,888 B2	11/2018	Chen et al.
9,943,310 B2 *	4/2018	Harris A61B 17/105	10,136,890 B2	11/2018	Shelton, IV et al.
9,962,158 B2	5/2018	Hall et al.	D836,198 S *	12/2018	Harris D24/145
9,962,161 B2	5/2018	Scheib et al.	10,149,679 B2	12/2018	Shelton, IV et al.
9,968,354 B2	5/2018	Shelton, IV et al.	10,149,680 B2	12/2018	Parihar et al.
9,968,355 B2	5/2018	Shelton, IV et al.	10,149,682 B2	12/2018	Shelton, IV et al.
			10,149,683 B2	12/2018	Smith et al.
			10,159,482 B2	12/2018	Swayze et al.
			10,159,483 B2	12/2018	Beckman et al.
			10,166,025 B2	1/2019	Leimbach et al.

(56)

References Cited

U.S. PATENT DOCUMENTS

10,166,026 B2	1/2019	Shelton, IV et al.	10,357,252 B2	7/2019	Harris et al.
10,172,616 B2	1/2019	Murray et al.	10,363,031 B2	7/2019	Alexander, III et al.
10,172,619 B2	1/2019	Harris et al.	10,363,032 B2 *	7/2019	Scheib A61B 17/072
10,178,992 B2	1/2019	Wise et al.	10,368,861 B2	8/2019	Baxter, III et al.
10,180,463 B2	1/2019	Beckman et al.	10,368,865 B2	8/2019	Harris et al.
10,182,816 B2	1/2019	Shelton, IV et al.	10,376,263 B2	8/2019	Morgan et al.
10,182,818 B2	1/2019	Hensel et al.	10,383,628 B2	8/2019	Kang et al.
10,182,819 B2	1/2019	Shelton, IV	10,383,629 B2	8/2019	Ross et al.
10,188,385 B2	1/2019	Kerr et al.	10,383,633 B2	8/2019	Shelton, IV et al.
10,188,393 B2	1/2019	Smith et al.	10,390,823 B2	8/2019	Shelton, IV et al.
10,188,394 B2	1/2019	Shelton, IV et al.	10,390,825 B2	8/2019	Shelton, IV et al.
10,194,910 B2	2/2019	Shelton, IV et al.	10,390,829 B2	8/2019	Eckert et al.
10,194,913 B2	2/2019	Nalagatla et al.	10,398,433 B2	9/2019	Boudreaux et al.
10,201,364 B2	2/2019	Leimbach et al.	10,398,436 B2	9/2019	Shelton, IV et al.
10,206,605 B2	2/2019	Shelton, IV et al.	10,405,854 B2	9/2019	Schmid et al.
10,206,677 B2	2/2019	Harris et al.	10,405,857 B2	9/2019	Shelton, IV et al.
10,206,678 B2	2/2019	Shelton, IV et al.	10,405,863 B2	9/2019	Wise et al.
10,213,198 B2	2/2019	Aronhalt et al.	10,413,291 B2	9/2019	Worthington et al.
10,213,201 B2	2/2019	Shelton, IV et al.	10,413,293 B2	9/2019	Shelton, IV et al.
10,213,262 B2	2/2019	Shelton, IV et al.	10,413,297 B2	9/2019	Harris et al.
10,226,250 B2	3/2019	Beckman et al.	10,420,552 B2	9/2019	Shelton, IV et al.
10,238,385 B2	3/2019	Yates et al.	10,420,553 B2	9/2019	Shelton, IV et al.
10,238,387 B2	3/2019	Yates et al.	10,420,558 B2	9/2019	Nalagatla et al.
10,238,390 B2	3/2019	Harris et al.	10,420,560 B2	9/2019	Shelton, IV et al.
10,238,391 B2	3/2019	Leimbach et al.	10,420,561 B2	9/2019	Shelton, IV et al.
10,245,027 B2	4/2019	Shelton, IV et al.	10,426,463 B2	10/2019	Shelton, IV et al.
10,245,028 B2	4/2019	Shelton, IV et al.	10,426,471 B2	10/2019	Shelton, IV et al.
10,245,029 B2	4/2019	Hunter et al.	10,426,476 B2	10/2019	Harris et al.
10,245,030 B2	4/2019	Hunter et al.	10,426,477 B2	10/2019	Harris et al.
10,245,032 B2	4/2019	Shelton, IV	10,426,478 B2	10/2019	Shelton, IV et al.
10,245,033 B2	4/2019	Overmyer et al.	10,433,837 B2	10/2019	Worthington et al.
10,245,035 B2	4/2019	Swayze et al.	10,433,844 B2	10/2019	Shelton, IV et al.
10,245,058 B2	4/2019	Omori et al.	10,433,845 B2	10/2019	Baxter, III et al.
10,251,648 B2	4/2019	Harris et al.	10,433,849 B2	10/2019	Shelton, IV et al.
10,258,330 B2	4/2019	Shelton, IV et al.	10,433,918 B2	10/2019	Shelton, IV et al.
10,258,331 B2	4/2019	Shelton, IV et al.	10,441,279 B2	10/2019	Shelton, IV et al.
10,258,333 B2	4/2019	Shelton, IV et al.	10,441,280 B2	10/2019	Timm et al.
10,258,336 B2	4/2019	Baxter, III et al.	10,441,285 B2	10/2019	Shelton, IV et al.
10,265,065 B2	4/2019	Shelton, IV et al.	10,441,369 B2	10/2019	Shelton, IV et al.
10,265,067 B2	4/2019	Yates et al.	10,448,948 B2	10/2019	Shelton, IV et al.
10,265,068 B2	4/2019	Harris et al.	10,448,950 B2	10/2019	Shelton, IV et al.
10,265,072 B2	4/2019	Shelton, IV et al.	10,456,132 B2	10/2019	Gettlinger et al.
10,265,073 B2	4/2019	Scheib et al.	10,456,133 B2	10/2019	Yates et al.
10,265,074 B2	4/2019	Shelton, IV et al.	10,456,140 B2	10/2019	Shelton, IV et al.
10,271,845 B2	4/2019	Shelton, IV	10,463,369 B2	11/2019	Shelton, IV et al.
10,271,846 B2	4/2019	Shelton, IV et al.	10,463,383 B2	11/2019	Shelton, IV et al.
10,271,851 B2	4/2019	Shelton, IV et al.	10,470,762 B2	11/2019	Leimbach et al.
D847,989 S	5/2019	Shelton, IV et al.	10,470,763 B2	11/2019	Yates et al.
10,278,697 B2	5/2019	Shelton, IV et al.	10,470,764 B2	11/2019	Baxter, III et al.
10,278,722 B2	5/2019	Shelton, IV et al.	10,470,768 B2	11/2019	Harris et al.
10,285,705 B2	5/2019	Shelton, IV et al.	10,470,769 B2	11/2019	Shelton, IV et al.
10,292,702 B2	5/2019	Cardinale et al.	10,478,190 B2	11/2019	Miller et al.
10,292,704 B2	5/2019	Harris et al.	10,485,536 B2	11/2019	Ming et al.
10,299,792 B2	5/2019	Huitema et al.	10,485,541 B2	11/2019	Shelton, IV
10,299,817 B2	5/2019	Shelton, IV et al.	10,485,542 B2	11/2019	Shelton, IV et al.
D850,617 S	6/2019	Shelton, IV et al.	10,485,543 B2	11/2019	Shelton, IV et al.
10,307,159 B2	6/2019	Harris et al.	10,485,546 B2	11/2019	Shelton, IV et al.
10,314,582 B2	6/2019	Shelton, IV et al.	D869,655 S *	12/2019	Shelton, IV D24/145
10,314,587 B2	6/2019	Harris et al.	10,492,785 B2	12/2019	Overmyer et al.
10,314,589 B2	6/2019	Shelton, IV et al.	10,492,787 B2	12/2019	Smith et al.
10,321,907 B2	6/2019	Shelton, IV et al.	10,499,890 B2	12/2019	Shelton, IV et al.
10,321,909 B2	6/2019	Shelton, IV et al.	10,499,908 B2	12/2019	Abbott et al.
10,327,765 B2	6/2019	Timm et al.	10,499,914 B2	12/2019	Huang et al.
10,327,776 B2 *	6/2019	Harris A61B 17/072	10,500,309 B2	12/2019	Shah et al.
10,335,144 B2	7/2019	Shelton, IV et al.	10,517,594 B2	12/2019	Shelton, IV et al.
10,335,148 B2	7/2019	Shelton, IV et al.	10,517,595 B2	12/2019	Hunter et al.
10,335,149 B2	7/2019	Baxter, III et al.	10,517,596 B2	12/2019	Hunter et al.
10,335,150 B2	7/2019	Shelton, IV	10,517,599 B2	12/2019	Baxter, III et al.
10,335,151 B2	7/2019	Shelton, IV et al.	10,517,682 B2	12/2019	Giordano et al.
10,342,533 B2	7/2019	Shelton, IV et al.	10,524,789 B2	1/2020	Swayze et al.
10,342,541 B2	7/2019	Shelton, IV et al.	10,524,795 B2	1/2020	Nalagatla et al.
10,342,543 B2	7/2019	Shelton, IV et al.	10,531,874 B2	1/2020	Morgan et al.
10,349,941 B2	7/2019	Marczyk et al.	10,537,325 B2	1/2020	Bakos et al.
10,357,246 B2	7/2019	Shelton, IV et al.	2001/0025183 A1	9/2001	Shahidi
10,357,251 B2	7/2019	Shelton, IV et al.	2002/0022836 A1	2/2002	Goble et al.
			2002/0029036 A1	3/2002	Goble et al.
			2002/0095175 A1	7/2002	Brock et al.
			2002/0103494 A1	8/2002	Pacey
			2002/0117534 A1	8/2002	Green et al.

(56)

References Cited

U.S. PATENT DOCUMENTS

- | | | | | | | | |
|--------------|----|---------|--------------------|--------------|----|---------|---------------------|
| 2002/0127265 | A1 | 9/2002 | Bowman et al. | 2005/0137455 | A1 | 6/2005 | Ewers et al. |
| 2002/0134811 | A1 | 9/2002 | Napier et al. | 2005/0139636 | A1 | 6/2005 | Schwemberger et al. |
| 2002/0143340 | A1 | 10/2002 | Kaneko | 2005/0143759 | A1 | 6/2005 | Kelly |
| 2003/0009193 | A1 | 1/2003 | Corsaro | 2005/0143769 | A1 | 6/2005 | White et al. |
| 2003/0039689 | A1 | 2/2003 | Chen et al. | 2005/0154258 | A1 | 7/2005 | Tartaglia et al. |
| 2003/0078647 | A1 | 4/2003 | Vallana et al. | 2005/0154406 | A1 | 7/2005 | Bombard et al. |
| 2003/0084983 | A1 | 5/2003 | Rangachari et al. | 2005/0165419 | A1 | 7/2005 | Sauer et al. |
| 2003/0093103 | A1 | 5/2003 | Malackowski et al. | 2005/0169974 | A1 | 8/2005 | Tenerz et al. |
| 2003/0096158 | A1 | 5/2003 | Takano et al. | 2005/0171522 | A1 | 8/2005 | Christopherson |
| 2003/0139741 | A1 | 7/2003 | Goble et al. | 2005/0177181 | A1 | 8/2005 | Kagan et al. |
| 2003/0153908 | A1 | 8/2003 | Goble et al. | 2005/0182298 | A1 | 8/2005 | Ikeda et al. |
| 2003/0163085 | A1 | 8/2003 | Tanner et al. | 2005/0187545 | A1 | 8/2005 | Hooven et al. |
| 2003/0181900 | A1 | 9/2003 | Long | 2005/0203550 | A1 | 9/2005 | Laufer et al. |
| 2003/0195387 | A1 | 10/2003 | Kortenbach et al. | 2005/0216055 | A1 | 9/2005 | Scirica et al. |
| 2003/0205029 | A1 | 11/2003 | Chapolini et al. | 2005/0228224 | A1 | 10/2005 | Okada et al. |
| 2003/0216732 | A1 | 11/2003 | Truckai et al. | 2005/0240178 | A1 | 10/2005 | Morley et al. |
| 2003/0236505 | A1 | 12/2003 | Bonadio et al. | 2005/0245965 | A1 | 11/2005 | Orban, III et al. |
| 2004/0006335 | A1 | 1/2004 | Garrison | 2005/0246881 | A1 | 11/2005 | Kelly et al. |
| 2004/0006340 | A1 | 1/2004 | Latterell et al. | 2005/0256452 | A1 | 11/2005 | DeMarchi et al. |
| 2004/0028502 | A1 | 2/2004 | Cummins | 2005/0261676 | A1 | 11/2005 | Hall et al. |
| 2004/0030333 | A1 | 2/2004 | Goble | 2005/0263563 | A1 | 12/2005 | Racenet et al. |
| 2004/0034357 | A1 | 2/2004 | Beane et al. | 2005/0267455 | A1 | 12/2005 | Eggers et al. |
| 2004/0044364 | A1 | 3/2004 | DeVries et al. | 2005/0283188 | A1 | 12/2005 | Loshakove et al. |
| 2004/0068161 | A1 | 4/2004 | Couvillon | 2006/0008787 | A1 | 1/2006 | Hayman et al. |
| 2004/0068224 | A1 | 4/2004 | Couvillon et al. | 2006/0015009 | A1 | 1/2006 | Jaffe et al. |
| 2004/0068307 | A1 | 4/2004 | Goble | 2006/0020258 | A1 | 1/2006 | Strauss et al. |
| 2004/0070369 | A1 | 4/2004 | Sakakibara | 2006/0020336 | A1 | 1/2006 | Liddicoat |
| 2004/0073222 | A1 | 4/2004 | Koseki | 2006/0025812 | A1 | 2/2006 | Shelton |
| 2004/0078037 | A1 | 4/2004 | Batchelor et al. | 2006/0041188 | A1 | 2/2006 | Dirusso et al. |
| 2004/0093024 | A1 | 5/2004 | Lousararian et al. | 2006/0047275 | A1 | 3/2006 | Goble |
| 2004/0098040 | A1 | 5/2004 | Taniguchi et al. | 2006/0049229 | A1 | 3/2006 | Milliman et al. |
| 2004/0101822 | A1 | 5/2004 | Wiesner et al. | 2006/0052824 | A1 | 3/2006 | Ransick et al. |
| 2004/0102783 | A1 | 5/2004 | Sutterlin et al. | 2006/0052825 | A1 | 3/2006 | Ransick et al. |
| 2004/0108357 | A1 | 6/2004 | Milliman et al. | 2006/0064086 | A1 | 3/2006 | Odom |
| 2004/0110439 | A1 | 6/2004 | Chaikof et al. | 2006/0079735 | A1 | 4/2006 | Martone et al. |
| 2004/0115022 | A1 | 6/2004 | Albertson et al. | 2006/0086032 | A1 | 4/2006 | Valencic et al. |
| 2004/0116952 | A1 | 6/2004 | Sakurai et al. | 2006/0087746 | A1 | 4/2006 | Lipow |
| 2004/0147909 | A1 | 7/2004 | Johnston et al. | 2006/0089535 | A1 | 4/2006 | Raz et al. |
| 2004/0164123 | A1 | 8/2004 | Racenet et al. | 2006/0100649 | A1 | 5/2006 | Hart |
| 2004/0167572 | A1 | 8/2004 | Roth et al. | 2006/0173470 | A1 | 8/2006 | Oray et al. |
| 2004/0181219 | A1 | 9/2004 | Goble et al. | 2006/0180634 | A1 | 8/2006 | Shelton et al. |
| 2004/0193189 | A1 | 9/2004 | Kortenbach et al. | 2006/0185682 | A1 | 8/2006 | Marczyk |
| 2004/0199181 | A1 | 10/2004 | Knodel et al. | 2006/0201989 | A1 | 9/2006 | Ojeda |
| 2004/0222268 | A1 | 11/2004 | Bilotti et al. | 2006/0212071 | A1 | 9/2006 | Ginn et al. |
| 2004/0225186 | A1 | 11/2004 | Horne et al. | 2006/0235368 | A1 | 10/2006 | Oz |
| 2004/0232201 | A1 | 11/2004 | Wenchell et al. | 2006/0252993 | A1 | 11/2006 | Freed et al. |
| 2004/0236352 | A1 | 11/2004 | Wang et al. | 2006/0271102 | A1 | 11/2006 | Bosshard et al. |
| 2004/0243147 | A1 | 12/2004 | Lipow | 2006/0287576 | A1 | 12/2006 | Tsuji et al. |
| 2004/0243151 | A1 | 12/2004 | Demmy et al. | 2006/0289602 | A1 | 12/2006 | Wales et al. |
| 2004/0243163 | A1 | 12/2004 | Casiano et al. | 2006/0291981 | A1 | 12/2006 | Viola et al. |
| 2004/0247415 | A1 | 12/2004 | Mangone | 2007/0010838 | A1 | 1/2007 | Shelton et al. |
| 2004/0254566 | A1 | 12/2004 | Plicchi et al. | 2007/0026039 | A1 | 2/2007 | Drumheller et al. |
| 2004/0254590 | A1 | 12/2004 | Hoffman et al. | 2007/0026040 | A1 | 2/2007 | Crawley et al. |
| 2004/0260315 | A1 | 12/2004 | Dell et al. | 2007/0027468 | A1 | 2/2007 | Wales et al. |
| 2004/0267310 | A1 | 12/2004 | Racenet et al. | 2007/0027551 | A1 | 2/2007 | Farnsworth et al. |
| 2005/0010213 | A1 | 1/2005 | Stad et al. | 2007/0049951 | A1 | 3/2007 | Menn |
| 2005/0032511 | A1 | 2/2005 | Malone et al. | 2007/0049966 | A1 | 3/2007 | Bonadio et al. |
| 2005/0033352 | A1 | 2/2005 | Zepf et al. | 2007/0051375 | A1 | 3/2007 | Milliman |
| 2005/0054946 | A1 | 3/2005 | Krzyzanowski | 2007/0073341 | A1 | 3/2007 | Smith et al. |
| 2005/0059997 | A1 | 3/2005 | Bauman et al. | 2007/0078484 | A1 | 4/2007 | Talarico et al. |
| 2005/0070929 | A1 | 3/2005 | Dalessandro et al. | 2007/0084897 | A1 | 4/2007 | Shelton et al. |
| 2005/0075561 | A1 | 4/2005 | Golden | 2007/0093869 | A1 | 4/2007 | Bloom et al. |
| 2005/0080342 | A1 | 4/2005 | Gilreath et al. | 2007/0102472 | A1 | 5/2007 | Shelton |
| 2005/0085693 | A1 | 4/2005 | Belson et al. | 2007/0106113 | A1 | 5/2007 | Ravo |
| 2005/0090817 | A1 | 4/2005 | Phan | 2007/0106317 | A1 | 5/2007 | Shelton et al. |
| 2005/0096605 | A1 | 5/2005 | Green et al. | 2007/0134251 | A1 | 6/2007 | Ashkenazi et al. |
| 2005/0096683 | A1 | 5/2005 | Ellins et al. | 2007/0135686 | A1 | 6/2007 | Pruitt et al. |
| 2005/0124855 | A1 | 6/2005 | Jaffe et al. | 2007/0135803 | A1 | 6/2007 | Belson |
| 2005/0125897 | A1 | 6/2005 | Wyslucha et al. | 2007/0155010 | A1 | 7/2007 | Farnsworth et al. |
| 2005/0131173 | A1 | 6/2005 | McDaniel et al. | 2007/0170225 | A1 | 7/2007 | Shelton et al. |
| 2005/0131211 | A1 | 6/2005 | Bayley et al. | 2007/0173687 | A1 | 7/2007 | Shima et al. |
| 2005/0131390 | A1 | 6/2005 | Heinrich et al. | 2007/0173813 | A1 | 7/2007 | Odom |
| 2005/0131436 | A1 | 6/2005 | Johnston et al. | 2007/0175950 | A1 | 8/2007 | Shelton et al. |
| 2005/0131457 | A1 | 6/2005 | Douglas et al. | 2007/0175951 | A1 | 8/2007 | Shelton et al. |
| 2005/0137454 | A1 | 6/2005 | Saadat et al. | 2007/0175955 | A1 | 8/2007 | Shelton et al. |
| | | | | 2007/0190110 | A1 | 8/2007 | Pameijer et al. |
| | | | | 2007/0191868 | A1 | 8/2007 | Theroux et al. |
| | | | | 2007/0194079 | A1 | 8/2007 | Hueil et al. |
| | | | | 2007/0194082 | A1 | 8/2007 | Morgan et al. |

(56)

References Cited

U.S. PATENT DOCUMENTS

2007/0203510	A1	8/2007	Bettuchi	2009/0188964	A1	7/2009	Orlov
2007/0208359	A1	9/2007	Hoffman	2009/0198272	A1	8/2009	Kerver et al.
2007/0213750	A1	9/2007	Weadock	2009/0204108	A1	8/2009	Steffen
2007/0225562	A1	9/2007	Spivey et al.	2009/0206125	A1	8/2009	Huitema et al.
2007/0233163	A1	10/2007	Bombard et al.	2009/0206126	A1	8/2009	Huitema et al.
2007/0243227	A1	10/2007	Gertner	2009/0206131	A1	8/2009	Weisenburgh, II et al.
2007/0244471	A1	10/2007	Malackowski	2009/0206133	A1	8/2009	Morgan et al.
2007/0246505	A1	10/2007	Pace-Florida et al.	2009/0206137	A1	8/2009	Hall et al.
2007/0275035	A1	11/2007	Herman et al.	2009/0206139	A1	8/2009	Hall et al.
2007/0276409	A1	11/2007	Ortiz et al.	2009/0206141	A1	8/2009	Huitema et al.
2007/0279011	A1	12/2007	Jones et al.	2009/0206142	A1	8/2009	Huitema et al.
2007/0286892	A1	12/2007	Herzberg et al.	2009/0242610	A1	10/2009	Shelton, IV et al.
2008/0003196	A1	1/2008	Jonn et al.	2009/0247901	A1	10/2009	Zimmer
2008/0015598	A1	1/2008	Prommersberger	2009/0255974	A1	10/2009	Viola
2008/0021278	A1	1/2008	Leonard et al.	2009/0270895	A1	10/2009	Churchill et al.
2008/0029570	A1	2/2008	Shelton et al.	2009/0275957	A1	11/2009	Harris et al.
2008/0029573	A1	2/2008	Shelton et al.	2009/0292283	A1	11/2009	Covidien Ag
2008/0029574	A1	2/2008	Shelton et al.	2009/0308907	A1	12/2009	Nalagatla et al.
2008/0029575	A1	2/2008	Shelton et al.	2009/0318957	A1	12/2009	Viola et al.
2008/0030170	A1	2/2008	Dacquay et al.	2010/0016888	A1	1/2010	Calabrese et al.
2008/0051833	A1	2/2008	Gramuglia et al.	2010/0023024	A1	1/2010	Zeiner et al.
2008/0065153	A1	3/2008	Allard et al.	2010/0023052	A1	1/2010	Heinrich et al.
2008/0078802	A1	4/2008	Hess et al.	2010/0036370	A1	2/2010	Mirel et al.
2008/0082114	A1	4/2008	McKenna et al.	2010/0069942	A1	3/2010	Shelton, IV
2008/0082125	A1	4/2008	Murray et al.	2010/0076483	A1	3/2010	Imuta
2008/0082126	A1	4/2008	Murray et al.	2010/0076489	A1	3/2010	Stopek et al.
2008/0085296	A1	4/2008	Powell et al.	2010/0100124	A1	4/2010	Calabrese et al.
2008/0086078	A1	4/2008	Powell et al.	2010/0133316	A1	6/2010	Lizee et al.
2008/0091072	A1	4/2008	Omori et al.	2010/0133317	A1	6/2010	Shelton, IV et al.
2008/0108443	A1	5/2008	Jinno et al.	2010/0145146	A1	6/2010	Melder
2008/0110958	A1*	5/2008	McKenna A61B 17/07207 227/176.1	2010/0147921	A1	6/2010	Olson
2008/0128469	A1	6/2008	Dalessandro et al.	2010/0147922	A1	6/2010	Olson
2008/0129253	A1	6/2008	Shiue et al.	2010/0179022	A1	7/2010	Shirokoshi
2008/0135600	A1	6/2008	Hiranuma et al.	2010/0191262	A1	7/2010	Harris et al.
2008/0140115	A1	6/2008	Stopek	2010/0193566	A1	8/2010	Scheib et al.
2008/0154299	A1	6/2008	Livneh	2010/0204717	A1	8/2010	Knodel
2008/0169328	A1	7/2008	Shelton	2010/0222901	A1	9/2010	Swayze et al.
2008/0169332	A1	7/2008	Shelton et al.	2010/0249497	A1	9/2010	Peine et al.
2008/0169333	A1	7/2008	Shelton et al.	2010/0267662	A1	10/2010	Fielder et al.
2008/0172087	A1	7/2008	Fuchs et al.	2010/0274160	A1	10/2010	Yachi et al.
2008/0190989	A1	8/2008	Crews et al.	2010/0292540	A1	11/2010	Hess et al.
2008/0197167	A1	8/2008	Viola et al.	2010/0298636	A1	11/2010	Castro et al.
2008/0200762	A1	8/2008	Stokes et al.	2010/0312261	A1	12/2010	Suzuki et al.
2008/0200835	A1	8/2008	Monson et al.	2010/0318085	A1	12/2010	Austin et al.
2008/0200933	A1	8/2008	Bakos et al.	2010/0331856	A1	12/2010	Carlson et al.
2008/0249536	A1	10/2008	Stahler et al.	2011/0006101	A1	1/2011	Hall et al.
2008/0255413	A1	10/2008	Zemlok et al.	2011/0011916	A1	1/2011	Levine
2008/0262654	A1	10/2008	Omori et al.	2011/0022032	A1	1/2011	Zemlok et al.
2008/0287944	A1	11/2008	Pearson et al.	2011/0024477	A1	2/2011	Hall
2008/0294179	A1	11/2008	Balbierz et al.	2011/0024478	A1	2/2011	Shelton, IV
2008/0296346	A1	12/2008	Shelton, IV et al.	2011/0036891	A1	2/2011	Zemlok et al.
2008/0297287	A1	12/2008	Shachar et al.	2011/0046667	A1	2/2011	Culligan et al.
2008/0308602	A1	12/2008	Timm et al.	2011/0060363	A1	3/2011	Hess et al.
2008/0308603	A1	12/2008	Shelton et al.	2011/0082485	A1	4/2011	Nohilly et al.
2008/0315829	A1	12/2008	Jones et al.	2011/0082538	A1	4/2011	Dahlgren et al.
2009/0001121	A1	1/2009	Hess et al.	2011/0084114	A1*	4/2011	Marczyk A61B 17/07207 227/178.1
2009/0001130	A1	1/2009	Hess et al.	2011/0087276	A1	4/2011	Bedi et al.
2009/0004455	A1	1/2009	Gravagna et al.	2011/0091515	A1	4/2011	Zilberman et al.
2009/0005809	A1	1/2009	Hess et al.	2011/0114697	A1	5/2011	Baxter, III et al.
2009/0012534	A1	1/2009	Madhani et al.	2011/0121049	A1	5/2011	Malinouskas et al.
2009/0020958	A1	1/2009	Soul	2011/0125176	A1	5/2011	Yates et al.
2009/0048589	A1	2/2009	Takashino et al.	2011/0137340	A1	6/2011	Cummins
2009/0076506	A1	3/2009	Baker	2011/0147433	A1	6/2011	Shelton, IV et al.
2009/0078736	A1	3/2009	Van Lue	2011/0163146	A1	7/2011	Ortiz et al.
2009/0081313	A1	3/2009	Aghion et al.	2011/0174861	A1	7/2011	Shelton, IV et al.
2009/0090763	A1	4/2009	Zemlok et al.	2011/0192882	A1	8/2011	Hess et al.
2009/0099579	A1	4/2009	Nentwick et al.	2011/0275901	A1	11/2011	Shelton, IV
2009/0099876	A1	4/2009	Whitman	2011/0276083	A1	11/2011	Shelton, IV et al.
2009/0119011	A1	5/2009	Kondo et al.	2011/0278343	A1	11/2011	Knodel et al.
2009/0143855	A1	6/2009	Weber et al.	2011/0290856	A1	12/2011	Shelton, IV et al.
2009/0149871	A9	6/2009	Kagan et al.	2011/0293690	A1	12/2011	Griffin et al.
2009/0171147	A1	7/2009	Lee et al.	2011/0295295	A1	12/2011	Shelton, IV et al.
2009/0177201	A1	7/2009	Soltz et al.	2011/0313894	A1	12/2011	Dye et al.
2009/0177226	A1	7/2009	Reinprecht et al.	2011/0315413	A1	12/2011	Fisher et al.
				2012/0004636	A1	1/2012	Lo
				2012/0016413	A1	1/2012	Timm et al.
				2012/0029272	A1	2/2012	Shelton, IV et al.
				2012/0074200	A1	3/2012	Schmid et al.

(56)

References Cited

U.S. PATENT DOCUMENTS

2012/0080336	A1	4/2012	Shelton, IV et al.	2014/0303645	A1	10/2014	Morgan et al.
2012/0080344	A1	4/2012	Shelton, IV	2014/0330161	A1	11/2014	Swayze et al.
2012/0080478	A1	4/2012	Morgan et al.	2015/0008248	A1	1/2015	Giordano et al.
2012/0080497	A1	4/2012	White et al.	2015/0053737	A1	2/2015	Leimbach et al.
2012/0080498	A1	4/2012	Shelton, IV et al.	2015/0053742	A1	2/2015	Shelton, IV et al.
2012/0109186	A1	5/2012	Parrott et al.	2015/0053743	A1	2/2015	Yates et al.
2012/0125792	A1	5/2012	Cassivi	2015/0053746	A1	2/2015	Shelton, IV et al.
2012/0130421	A1	5/2012	Hafez et al.	2015/0053748	A1	2/2015	Yates et al.
2012/0175398	A1	7/2012	Sandborn et al.	2015/0060518	A1	3/2015	Shelton, IV et al.
2012/0234895	A1	9/2012	O'Connor et al.	2015/0060519	A1	3/2015	Shelton, IV et al.
2012/0234897	A1	9/2012	Shelton, IV et al.	2015/0060520	A1	3/2015	Shelton, IV et al.
2012/0248169	A1	10/2012	Widenhouse et al.	2015/0060521	A1	3/2015	Weisenburgh, II et al.
2012/0283707	A1	11/2012	Giordano et al.	2015/0076208	A1	3/2015	Shelton, IV
2012/0289979	A1	11/2012	Eskaros et al.	2015/0076209	A1	3/2015	Shelton, IV et al.
2012/0292367	A1	11/2012	Morgan et al.	2015/0076210	A1	3/2015	Shelton, IV et al.
2012/0298722	A1	11/2012	Hess et al.	2015/0076212	A1	3/2015	Shelton, IV
2012/0303002	A1	11/2012	Chowaniec et al.	2015/0080868	A1	3/2015	Kerr
2013/0006227	A1	1/2013	Takashino	2015/0083781	A1	3/2015	Giordano et al.
2013/0012983	A1	1/2013	Kleyman	2015/0083782	A1	3/2015	Scheib et al.
2013/0020375	A1	1/2013	Shelton, IV et al.	2015/0090760	A1	4/2015	Giordano et al.
2013/0020376	A1	1/2013	Shelton, IV et al.	2015/0090762	A1	4/2015	Giordano et al.
2013/0023861	A1	1/2013	Shelton, IV et al.	2015/0122870	A1	5/2015	Zemlok et al.
2013/0026208	A1	1/2013	Shelton, IV et al.	2015/0144679	A1*	5/2015	Scirica A61B 17/105 227/180.1
2013/0026210	A1	1/2013	Shelton, IV et al.	2015/0150620	A1	6/2015	Miyamoto et al.
2013/0030462	A1	1/2013	Keating et al.	2015/0173749	A1	6/2015	Shelton, IV et al.
2013/0041406	A1	2/2013	Bear et al.	2015/0173756	A1	6/2015	Baxter, III et al.
2013/0087597	A1	4/2013	Shelton, IV et al.	2015/0173789	A1	6/2015	Baxter, III et al.
2013/0098970	A1	4/2013	Racenet et al.	2015/0196295	A1	7/2015	Shelton, IV et al.
2013/0116669	A1	5/2013	Shelton, IV et al.	2015/0196296	A1	7/2015	Swayze et al.
2013/0131651	A1	5/2013	Strobl et al.	2015/0196299	A1	7/2015	Swayze et al.
2013/0153641	A1	6/2013	Shelton, IV et al.	2015/0201932	A1	7/2015	Swayze et al.
2013/0175317	A1	7/2013	Yates et al.	2015/0201936	A1	7/2015	Swayze et al.
2013/0214025	A1	8/2013	Zemlok et al.	2015/0201937	A1	7/2015	Swayze et al.
2013/0233906	A1	9/2013	Hess et al.	2015/0201938	A1	7/2015	Swayze et al.
2013/0256373	A1	10/2013	Schmid et al.	2015/0201939	A1	7/2015	Swayze et al.
2013/0256380	A1	10/2013	Schmid et al.	2015/0201940	A1	7/2015	Swayze et al.
2013/0261661	A1	10/2013	Piraka	2015/0201941	A1	7/2015	Swayze et al.
2013/0270322	A1	10/2013	Scheib et al.	2015/0201949	A1	8/2015	Racenet et al.
2013/0317305	A1	11/2013	Stevenson et al.	2015/0272557	A1	10/2015	Overmyer et al.
2013/0334280	A1	12/2013	Krehel et al.	2015/0272571	A1	10/2015	Leimbach et al.
2013/0334283	A1	12/2013	Swayze et al.	2015/0272580	A1	10/2015	Leimbach et al.
2013/0334285	A1	12/2013	Swayze et al.	2015/0272582	A1	10/2015	Leimbach et al.
2013/0341374	A1	12/2013	Shelton, IV et al.	2015/0297222	A1*	10/2015	Huitema A61B 17/068 227/176.1
2014/0001231	A1	1/2014	Shelton, IV et al.	2015/0297223	A1	10/2015	Huitema et al.
2014/0001234	A1	1/2014	Shelton, IV et al.	2015/0297225	A1	10/2015	Huitema et al.
2014/0005640	A1	1/2014	Shelton, IV et al.	2015/0297228	A1	10/2015	Huitema et al.
2014/0005678	A1	1/2014	Shelton, IV et al.	2015/0297229	A1	10/2015	Schellin et al.
2014/0005702	A1	1/2014	Timm et al.	2015/0297233	A1	10/2015	Huitema et al.
2014/0005718	A1	1/2014	Shelton, IV et al.	2015/0297234	A1	10/2015	Schellin et al.
2014/0012299	A1	1/2014	Stoddard et al.	2015/0313594	A1	11/2015	Shelton, IV et al.
2014/0014705	A1	1/2014	Baxter, III	2015/0324317	A1	11/2015	Collins et al.
2014/0018832	A1	1/2014	Shelton, IV	2015/0327864	A1	11/2015	Hodgkinson et al.
2014/0039549	A1	2/2014	Belsky et al.	2015/0374369	A1	12/2015	Yates et al.
2014/0048580	A1	2/2014	Merchant et al.	2015/0374378	A1	12/2015	Giordano et al.
2014/0103098	A1	4/2014	Choi et al.	2016/0000431	A1	1/2016	Giordano et al.
2014/0107640	A1	4/2014	Yates et al.	2016/0000437	A1	1/2016	Giordano et al.
2014/0151433	A1	6/2014	Shelton, IV et al.	2016/0000438	A1	1/2016	Swayze et al.
2014/0158747	A1	6/2014	Measamer et al.	2016/0000442	A1	1/2016	Shelton, IV
2014/0166724	A1	6/2014	Schellin et al.	2016/0000452	A1	1/2016	Yates et al.
2014/0166725	A1	6/2014	Schellin et al.	2016/0000453	A1	1/2016	Yates et al.
2014/0166726	A1	6/2014	Schellin et al.	2016/0058443	A1	3/2016	Yates et al.
2014/0175152	A1	6/2014	Hess et al.	2016/0066913	A1	3/2016	Swayze et al.
2014/0188159	A1	7/2014	Steege	2016/0074040	A1	3/2016	Widenhouse et al.
2014/0224857	A1	8/2014	Schmid	2016/0089137	A1	3/2016	Hess et al.
2014/0243865	A1	8/2014	Swayze et al.	2016/0089142	A1*	3/2016	Harris A61B 17/07207 606/219
2014/0246475	A1	9/2014	Hall et al.	2016/0095585	A1	4/2016	Zergiebel et al.
2014/0248167	A1	9/2014	Sugimoto et al.	2016/0106426	A1*	4/2016	Shelton, IV A61B 17/07207 227/176.1
2014/0249557	A1	9/2014	Koch et al.	2016/0106427	A1*	4/2016	Shelton, IV A61B 17/07207 227/180.1
2014/0263541	A1	9/2014	Leimbach et al.	2016/0106431	A1	4/2016	Shelton, IV et al.
2014/0263552	A1	9/2014	Hall et al.	2016/0113653	A1	4/2016	Zingman
2014/0263558	A1	9/2014	Hausen et al.	2016/0120545	A1	5/2016	Shelton, IV et al.
2014/0284371	A1	9/2014	Morgan et al.	2016/0166256	A1	6/2016	Baxter, III et al.
2014/0291379	A1	10/2014	Schellin et al.	2016/0174974	A1	6/2016	Schmid et al.
2014/0291383	A1	10/2014	Spivey et al.	2016/0183939	A1	6/2016	Shelton, IV et al.
2014/0299648	A1	10/2014	Shelton, IV et al.				

(56)

References Cited

U.S. PATENT DOCUMENTS

2016/0183943 A1 6/2016 Shelton, IV
 2016/0183944 A1 6/2016 Swensgard et al.
 2016/0192916 A1 7/2016 Shelton, IV et al.
 2016/0192918 A1 7/2016 Shelton, IV et al.
 2016/0199063 A1 7/2016 Mandakolathur Vasudevan et al.
 2016/0199089 A1 7/2016 Hess et al.
 2016/0199956 A1 7/2016 Shelton, IV et al.
 2016/0206314 A1 7/2016 Scheib et al.
 2016/0235404 A1 8/2016 Shelton, IV
 2016/0235409 A1 8/2016 Shelton, IV et al.
 2016/0235494 A1 8/2016 Shelton, IV et al.
 2016/0242783 A1 8/2016 Shelton, IV et al.
 2016/0249910 A1 9/2016 Shelton, IV et al.
 2016/0249922 A1 9/2016 Morgan et al.
 2016/0256071 A1 9/2016 Shelton, IV et al.
 2016/0256154 A1 9/2016 Shelton, IV et al.
 2016/0256160 A1 9/2016 Shelton, IV et al.
 2016/0256229 A1 9/2016 Morgan et al.
 2016/0262745 A1 9/2016 Morgan et al.
 2016/0262746 A1 9/2016 Shelton, IV et al.
 2016/0270780 A1 9/2016 Hall et al.
 2016/0270789 A1* 9/2016 Gupta A61B 17/07207
 2016/0338702 A1* 11/2016 Ehrenfels A61B 17/07207
 2017/0027572 A1 2/2017 Nalagatla et al.
 2017/0055996 A1* 3/2017 Baxter, III A61B 17/072
 2017/0055997 A1* 3/2017 Swayze A61B 17/064
 2017/0056000 A1 3/2017 Nalagatla et al.
 2017/0056002 A1 3/2017 Nalagatla et al.
 2017/0056005 A1 3/2017 Shelton, IV et al.
 2017/0095250 A1* 4/2017 Kostrzewski A61B 17/07207
 2017/0105727 A1 4/2017 Scheib et al.
 2017/0105731 A1 4/2017 Scheib et al.
 2017/0119388 A1 5/2017 Kostrzewski
 2017/0224331 A1 8/2017 Worthington et al.
 2017/0224332 A1 8/2017 Hunter et al.
 2017/0224334 A1 8/2017 Worthington et al.
 2017/0224335 A1 8/2017 Weaner et al.
 2017/0231627 A1 8/2017 Shelton, IV et al.
 2017/0231628 A1 8/2017 Shelton, IV et al.
 2017/0231633 A1* 8/2017 Marczyk A61B 17/068
 227/175.2
 2017/0245856 A1 8/2017 Baxter, III et al.
 2017/0245857 A1 8/2017 Shelton, IV et al.
 2017/0281164 A1 10/2017 Harris et al.
 2017/0281169 A1 10/2017 Harris et al.
 2017/0281171 A1 10/2017 Shelton, IV et al.
 2017/0281173 A1 10/2017 Shelton, IV et al.
 2017/0281174 A1 10/2017 Harris et al.
 2017/0281183 A1 10/2017 Miller et al.
 2017/0281184 A1 10/2017 Shelton, IV et al.
 2017/0281186 A1 10/2017 Shelton, IV et al.
 2017/0281187 A1 10/2017 Shelton, IV et al.
 2017/0281189 A1 10/2017 Nalagatla et al.
 2017/0303924 A1* 10/2017 Scheib A61B 17/068
 2017/0360423 A1 12/2017 Stevenson et al.
 2017/0367695 A1 12/2017 Shelton, IV et al.
 2017/0367696 A1 12/2017 Shelton, IV et al.
 2017/0367697 A1 12/2017 Shelton, IV et al.
 2017/0367698 A1 12/2017 Shelton, IV et al.
 2017/0367699 A1 12/2017 Shelton, IV et al.
 2018/0103948 A1 4/2018 Baxter, III et al.
 2018/0110513 A1 4/2018 Baxter, III et al.
 2018/0110517 A1 4/2018 Baxter, III et al.
 2018/0125484 A1* 5/2018 Kostrzewski A61B 17/07207
 2018/0168575 A1 6/2018 Simms et al.
 2018/0168577 A1 6/2018 Aronhalt et al.
 2018/0168578 A1 6/2018 Aronhalt et al.
 2018/0168579 A1 6/2018 Aronhalt et al.
 2018/0168580 A1 6/2018 Hunter et al.
 2018/0168581 A1 6/2018 Hunter et al.
 2018/0168584 A1 6/2018 Harris et al.
 2018/0168585 A1* 6/2018 Shelton, IV A61B 17/072
 2018/0168586 A1* 6/2018 Shelton, IV A61B 17/072
 2018/0168589 A1 6/2018 Swayze et al.
 2018/0168590 A1 6/2018 Overmyer et al.

2018/0168591 A1 6/2018 Swayze et al.
 2018/0168592 A1 6/2018 Overmyer et al.
 2018/0168593 A1 6/2018 Overmyer et al.
 2018/0168594 A1 6/2018 Shelton, IV et al.
 2018/0168596 A1 6/2018 Beckman et al.
 2018/0168597 A1 6/2018 Fanelli et al.
 2018/0168598 A1 6/2018 Shelton, IV et al.
 2018/0168600 A1* 6/2018 Shelton, IV A61B 17/07207
 2018/0168601 A1 6/2018 Bakos et al.
 2018/0168602 A1 6/2018 Bakos et al.
 2018/0168603 A1 6/2018 Morgan et al.
 2018/0168604 A1 6/2018 Shelton, IV et al.
 2018/0168605 A1 6/2018 Baber et al.
 2018/0168606 A1 6/2018 Shelton, IV et al.
 2018/0168607 A1 6/2018 Shelton, IV et al.
 2018/0168608 A1 6/2018 Shelton, IV et al.
 2018/0168609 A1 6/2018 Fanelli et al.
 2018/0168610 A1 6/2018 Shelton, IV et al.
 2018/0168613 A1 6/2018 Shelton, IV et al.
 2018/0168614 A1 6/2018 Shelton, IV et al.
 2018/0168615 A1 6/2018 Shelton, IV et al.
 2018/0168616 A1 6/2018 Shelton, IV et al.
 2018/0168617 A1 6/2018 Shelton, IV et al.
 2018/0168618 A1 6/2018 Scott et al.
 2018/0168619 A1 6/2018 Scott et al.
 2018/0168621 A1 6/2018 Shelton, IV et al.
 2018/0168623 A1 6/2018 Simms et al.
 2018/0168624 A1 6/2018 Shelton, IV et al.
 2018/0168625 A1 6/2018 Posada et al.
 2018/0168626 A1 6/2018 Shelton, IV et al.
 2018/0168627 A1 6/2018 Weaner et al.
 2018/0168628 A1 6/2018 Hunter et al.
 2018/0168629 A1* 6/2018 Shelton, IV A61B 17/07207
 2018/0168630 A1 6/2018 Shelton, IV et al.
 2018/0168631 A1 6/2018 Harris et al.
 2018/0168632 A1 6/2018 Harris et al.
 2018/0168633 A1 6/2018 Shelton, IV et al.
 2018/0168634 A1 6/2018 Harris et al.
 2018/0168635 A1 6/2018 Shelton, IV et al.
 2018/0168636 A1 6/2018 Shelton, IV et al.
 2018/0168637 A1* 6/2018 Harris A61B 17/07207
 2018/0168638 A1 6/2018 Harris et al.
 2018/0168639 A1 6/2018 Shelton, IV et al.
 2018/0168640 A1 6/2018 Shelton, IV et al.
 2018/0168641 A1 6/2018 Harris et al.
 2018/0168642 A1 6/2018 Shelton, IV et al.
 2018/0168643 A1* 6/2018 Shelton, IV A61B 17/07207
 2018/0168644 A1 6/2018 Shelton, IV et al.
 2018/0168645 A1 6/2018 Shelton, IV et al.
 2018/0168646 A1 6/2018 Shelton, IV et al.
 2018/0168647 A1* 6/2018 Shelton, IV A61B 17/07207
 2018/0168648 A1* 6/2018 Shelton, IV A61B 17/07207
 2018/0168649 A1 6/2018 Shelton, IV et al.
 2018/0168650 A1* 6/2018 Shelton, IV A61B 17/07207
 2018/0168651 A1 6/2018 Shelton, IV et al.
 2019/0059886 A1* 2/2019 Shelton, IV A61B 17/07207
 2019/0059887 A1* 2/2019 Beardsley A61B 17/07207
 2019/0105047 A1* 4/2019 Nalagatla A61B 17/072
 2019/0125344 A1* 5/2019 DiNardo A61B 17/07207
 2019/0150927 A1* 5/2019 Aranyi A61B 17/105
 2019/0261992 A1 8/2019 Shelton, IV et al.
 2019/0269402 A1* 9/2019 Murray A61B 17/072
 2019/0290279 A1 9/2019 Harris et al.
 2019/0328390 A1* 10/2019 Harris A61B 17/0682
 2020/0015822 A1* 1/2020 Marczyk A61B 17/105

FOREIGN PATENT DOCUMENTS

CA 2813230 A1 4/2012
 CA 2795323 A1 5/2014
 CN 1163558 A 10/1997
 CN 2488482 Y 5/2002
 CN 1634601 A 7/2005
 CN 2716900 Y 8/2005
 CN 2738962 Y 11/2005
 CN 2868212 Y 2/2007
 CN 201949071 U 8/2011
 CN 101779977 B 12/2011
 CN 202397539 U 8/2012

(56)

References Cited

FOREIGN PATENT DOCUMENTS

CN	202982106	U	6/2013	FR	1112936	A	3/1956
CN	203777011	U	8/2014	FR	2598905	A1	11/1987
DE	273689	C	5/1914	FR	2765794	A1	1/1999
DE	1775926	A	1/1972	FR	2815842	A1	5/2002
DE	3036217	A1	4/1982	GB	939929	A	10/1963
DE	3210466	A1	9/1983	GB	1210522	A	10/1970
DE	3709067	A1	9/1988	GB	1217159	A	12/1970
DE	19851291	A1	1/2000	GB	1339394	A	12/1973
DE	19924311	A1	11/2000	GB	2024012	A	1/1980
DE	20016423	U1	2/2001	GB	2109241	A	6/1983
DE	20112837	U1	10/2001	GB	2272159	A	5/1994
DE	20121753	U1	4/2003	GB	2336214	A	10/1999
DE	202004012389	U1	9/2004	GR	930100110	A	11/1993
DE	10314072	A1	10/2004	JP	S4711908	Y1	5/1972
DE	202007003114	U1	6/2007	JP	S56112235	A	9/1981
EP	0000756	A1	2/1979	JP	S62170011	U	10/1987
EP	0122046	A1	10/1984	JP	H04215747	A	8/1992
EP	0129442	B1	11/1987	JP	H04131860	U	12/1992
EP	0169044	B1	6/1991	JP	H0584252	A	4/1993
EP	0548998	A1	6/1993	JP	H05123325	A	5/1993
EP	0594148	A1	4/1994	JP	H0630945	A	2/1994
EP	0646357	A1	4/1995	JP	H06237937	A	8/1994
EP	0505036	B1	5/1995	JP	H06327684	A	11/1994
EP	0669104	A1	8/1995	JP	H079622	U	2/1995
EP	0705571	A1	4/1996	JP	H07124166	A	5/1995
EP	0528478	B1	5/1996	JP	H07255735	A	10/1995
EP	0770355	A1	5/1997	JP	H07285089	A	10/1995
EP	0625335	B1	11/1997	JP	H08164141	A	6/1996
EP	0879742	A1	11/1998	JP	H08182684	A	7/1996
EP	0650701	B1	3/1999	JP	H08507708	A	8/1996
EP	0923907	A1	6/1999	JP	H08229050	A	9/1996
EP	0484677	B2	7/2000	JP	H10118090	A	5/1998
EP	1034747	A1	9/2000	JP	2000014632	A	1/2000
EP	1034748	A1	9/2000	JP	2000033071	A	2/2000
EP	1053719	A1	11/2000	JP	2000112002	A	4/2000
EP	1055399	A1	11/2000	JP	2000166932	A	6/2000
EP	1055400	A1	11/2000	JP	2000171730	A	6/2000
EP	1080694	A1	3/2001	JP	2000287987	A	10/2000
EP	1090592	A1	4/2001	JP	2000325303	A	11/2000
EP	1095627	A1	5/2001	JP	2001087272	A	4/2001
EP	0806914	B1	9/2001	JP	2001514541	A	9/2001
EP	1284120	A1	2/2003	JP	2001276091	A	10/2001
EP	0869742	B1	5/2003	JP	2002051974	A	2/2002
EP	1374788	A1	1/2004	JP	2002085415	A	3/2002
EP	1407719	A2	4/2004	JP	2002143078	A	5/2002
EP	0996378	B1	6/2004	JP	2002528161	A	9/2002
EP	1157666	B1	9/2005	JP	2002314298	A	10/2002
EP	0880338	B1	10/2005	JP	2003135473	A	5/2003
EP	1158917	B1	11/2005	JP	2003521301	A	7/2003
EP	1344498	B1	11/2005	JP	2003300416	A	10/2003
EP	1330989	B1	12/2005	JP	2004147701	A	5/2004
EP	1632191	A2	3/2006	JP	2004162035	A	6/2004
EP	1082944	B1	5/2006	JP	2004229976	A	8/2004
EP	1253866	B1	7/2006	JP	2005013573	A	1/2005
EP	1285633	B1	12/2006	JP	2005080702	A	3/2005
EP	1011494	B1	1/2007	JP	2005131163	A	5/2005
EP	1767163	A1	3/2007	JP	2005131164	A	5/2005
EP	1837041	A1	9/2007	JP	2005131173	A	5/2005
EP	0922435	B1	10/2007	JP	2005131211	A	5/2005
EP	1599146	B1	10/2007	JP	2005131212	A	5/2005
EP	1330201	B1	6/2008	JP	2005137423	A	6/2005
EP	2039302	A2	3/2009	JP	2005328882	A	12/2005
EP	1719461	B1	6/2009	JP	2005335432	A	12/2005
EP	1769754	B1	6/2010	JP	2005342267	A	12/2005
EP	1627605	B1	12/2010	JP	2006187649	A	7/2006
EP	2316345	A1	5/2011	JP	2006281405	A	10/2006
EP	1936253	B1	10/2011	JP	2006346445	A	12/2006
EP	2486862	A2	8/2012	JP	2009507526	A	2/2009
EP	2517638	A1	10/2012	JP	2009189838	A	8/2009
EP	2649948	A1	10/2013	JP	2009539420	A	11/2009
EP	2649949	A1	10/2013	JP	2010069310	A	4/2010
EP	2713902	A1	4/2014	JP	2010098844	A	4/2010
EP	2621364	B1	6/2017	JP	2011524199	A	9/2011
FR	459743	A	11/1913	KR	20110003229	A	1/2011
FR	999646	A	2/1952	RU	2008830	C1	3/1994
				RU	2052979	C1	1/1996
				RU	2098025	C1	12/1997
				RU	2141279	C1	11/1999
				RU	2144791	C1	1/2000

(56)

References Cited

FOREIGN PATENT DOCUMENTS

RU 2161450 C1 1/2001
 RU 2181566 C2 4/2002
 RU 2187249 C2 8/2002
 RU 32984 U1 10/2003
 RU 2225170 C2 3/2004
 RU 42750 U1 12/2004
 RU 61114 U1 2/2007
 SU 189517 A 1/1967
 SU 328636 A 9/1972
 SU 674747 A1 7/1979
 SU 1009439 A 4/1983
 SU 1333319 A2 8/1987
 SU 1377053 A1 2/1988
 SU 1509051 A1 9/1989
 SU 1561964 A1 5/1990
 SU 1708312 A1 1/1992
 SU 1722476 A1 3/1992
 SU 1752361 A1 8/1992
 SU 1814161 A1 5/1993
 WO WO-9315648 A1 8/1993
 WO WO-9420030 A1 9/1994
 WO WO-9517855 A1 7/1995
 WO WO-9520360 A1 8/1995
 WO WO-9623448 A1 8/1996
 WO WO-9635464 A1 11/1996
 WO WO-9639086 A1 12/1996
 WO WO-9639088 A1 12/1996
 WO WO-9724073 A1 7/1997
 WO WO-9734533 A1 9/1997
 WO WO-9903407 A1 1/1999
 WO WO-9903409 A1 1/1999
 WO WO-9948430 A1 9/1999
 WO WO-0024322 A1 5/2000
 WO WO-0024330 A1 5/2000
 WO WO-0053112 A2 9/2000
 WO WO-0057796 A1 10/2000
 WO WO-0105702 A1 1/2001
 WO WO-0154594 A1 8/2001
 WO WO-0158371 A1 8/2001
 WO WO-0162164 A2 8/2001
 WO WO-0162169 A2 8/2001
 WO WO-0191646 A1 12/2001
 WO WO-0219932 A1 3/2002
 WO WO-0226143 A1 4/2002
 WO WO-0236028 A1 5/2002
 WO WO-02065933 A2 8/2002
 WO WO-03055402 A1 7/2003
 WO WO-03094747 A1 11/2003
 WO WO-03079909 A3 3/2004
 WO WO-2004019803 A1 3/2004
 WO WO-2004032783 A1 4/2004
 WO WO-2004047626 A1 6/2004
 WO WO-2004047653 A2 6/2004
 WO WO-2004056277 A1 7/2004
 WO WO-2004078050 A2 9/2004
 WO WO-2004078051 A2 9/2004
 WO WO-2004096015 A2 11/2004
 WO WO-2006044581 A2 4/2006
 WO WO-2006051252 A1 5/2006
 WO WO-2006059067 A1 6/2006
 WO WO-2006085389 A1 8/2006
 WO WO-2007074430 A1 7/2007
 WO WO-2007129121 A1 11/2007
 WO WO-2007137304 A2 11/2007
 WO WO-2007142625 A2 12/2007
 WO WO-2008021969 A2 2/2008
 WO WO-2008089404 A2 7/2008
 WO WO-2009005969 A2 1/2009
 WO WO-2009067649 A2 5/2009
 WO WO-2009091497 A2 7/2009
 WO WO-2011008672 A2 1/2011
 WO WO-2011044343 A2 4/2011
 WO WO-2012006306 A2 1/2012
 WO WO-2012013577 A1 2/2012
 WO WO-2012044606 A2 4/2012

WO WO-2012166503 A1 12/2012
 WO WO-2013151888 A1 10/2013
 WO WO-2015153340 A2 10/2015

OTHER PUBLICATIONS

Li et al. "Mg-Zr-Sr Alloys as Biodegradable Implant Materials," *Acta Biomaterialia* 8 (2012) 3177-3188 (12 pages).
 Brar et al., "Investigation of the mechanical and degradation properties of Mg-Sr and Mg-Zn-Sr alloys for use as potential biodegradable implant materials," *J. Mech. Behavior of Biomed. Mater.* 7 (2012) pp. 87-95.
 Fast, Versatile Blackfin Processors Handle Advanced RFID Reader Applications; Analog Dialogue: vol. 40—Sep. 2006; <http://www.analog.com/library/analogDialogue/archives/40-09/rfid.pdf>; Wayback Machine to Feb. 15, 2012.
 Covidien Brochure, "Endo GIA™ Black Reload with Tri-Staple™ Technology," (2012), 2 pages.
 Erdmann et al., "Evaluation of the Soft Tissue Biocompatibility of MgCa0.8 and Surgical Steel 316L in Vivo: A Comparative Study In Rabbits," *Biomed. Eng. OnLine* 2010 9:63 (17 pages).
 The Sodem Aseptic Battery Transfer Kit, Sodem Systems, 2000, 3 pages.
 Yan et al, Comparison of the effects of Mg-6Zn and Ti-3Al-2.5V alloys on TGF- β /TNF- α /VEGF/b-FGF in the healing of the intestinal track in vivo, *Biomed. Mater.* 9 (2014), 11 pages.
 Pellicer et al. "On the biodegradability, mechanical behavior, and cytocompatibility of amorphous Mg72Zn23Ca5 and crystalline Mg70Zn23Ca5Pd2 alloys as temporary implant materials," *J Biomed Mater Res Part A*, 2013:101A:502-517.
 Yan et al., "Comparison of the effects of Mg-6Zn and titanium on intestinal tract in vivo," *J Mater Sci: Mater Med* (2013), 11 pages.
 Schellhammer et al., "Poly-Lactic-Acid for Coating of Endovascular Stents: Preliminary Results in Canine Experimental Av-Fistulae," *Mat.-wiss. u. Werkstofftech.*, 32, pp. 193-199 (2001).
 Miyata et al., "Biomolecule-Sensitive Hydrogels," *Advanced Drug Delivery Reviews*, 54 (2002) pp. 79-98.
 Jeong et al., "Thermosensitive Sol-Gel Reversible Hydrogels," *Advanced Drug Delivery Reviews*, 54 (2002) pp. 37-51.
 Covidien Brochure, "Endo GIA™ Ultra Universal Stapler," (2010), 2 pages.
 Qiu et al., "Environment-Sensitive Hydrogels for Drug Delivery," *Advanced Drug Delivery Reviews*, 53 (2001) pp. 321-339.
 Hoffman, "Hydrogels for Biomedical Applications," *Advanced Drug Delivery Reviews*, 43 (2002) pp. 3-12.
 Hoffman, "Hydrogels for Biomedical Applications," *Advanced Drug Delivery Reviews*, 54 (2002) pp. 3-12.
 Peppas, "Physiologically Responsive Hydrogels," *Journal of Bioactive and Compatible Polymers*, vol. 6 (Jul. 1991) pp. 241-246.
 Peppas, Editor "Hydrogels in Medicine and Pharmacy," vol. I, Fundamentals, CRC Press, 1986.
 Young, "Microcellular foams via phase separation," *Journal of Vacuum Science & Technology* 4(3), (May/Jun. 1986).
 Chen et al., "Elastomeric Biomaterials for Tissue Engineering," *Progress in Polymer Science* 38 (2013), pp. 584-671.
 Ebara, "Carbohydrate-Derived Hydrogels and Microgels," *Engineered Carbohydrate-Based Materials for Biomedical Applications: Polymers, Surfaces, Dendrimers, Nanoparticles, and Hydrogels*, Edited by Ravin Narain, 2011, pp. 337-345.
 Matsuda, "Thermodynamics of Formation of Porous Polymeric Membrane from Solutions," *Polymer Journal*, vol. 23, no. 5, pp. 435-444 (1991).
 Byrne et al., "Molecular Imprinting Within Hydrogels," *Advanced Drug Delivery Reviews*, 54 (2002) pp. 149-161.
 Covidien Brochure, "Endo GIA™ Reloads with Tri-Staple™ Technology," (2010), 1 page.
 Covidien Brochure, "Endo GIA™ Reloads with Tri-Staple™ Technology and Endo GIA™ Ultra Universal Staplers," (2010), 2 pages.
 Covidien Brochure, "Endo GIA™ Curved Tip Reload with Tri-Staple™ Technology," (2012), 2 pages.
 Covidien Brochure, "Endo GIA™ Reloads with Tri-Staple™ Technology," (2010), 2 pages.

(56)

References Cited

OTHER PUBLICATIONS

<http://ninpgan.net/publications/51-100/89.pdf>; 2004, Ning Pan, On Uniqueness of Fibrous Materials, Design & Nature II. Eds: Colins, M. And Brebbia, C. WIT Press, Boston, 493-504.

D. Tuite, Ed., "Get the Lowdown on Ultracapacitors," Nov. 15, 2007; [online] URL: <http://electronicdesign.com/Articles/Print.cfm?ArticleID=17465>, accessed Jan. 15, 2008 (5 pages).

C.C. Thompson et al., "Peroral Endoscopic Reduction of Dilated Gastrojejunal Anastomosis After Roux-en-Y Gastric Bypass: A Possible New Option for Patients with Weight Regain," Surg Endosc (2006) vol. 20., pp. 1744-1748.

Datasheet for Panasonic TK Relays Ultra Low Profile 2 A Polarized Relay, Copyright Matsushita Electric Works, Ltd. (Known of at least as early as Aug. 17, 2010), 5 pages.

B.R. Coolman, DVM, MS et al., "Comparison of Skin Staples With Sutures for Anastomosis of the Small Intestine in Dogs," Abstract; <http://www.blackwell-synergy.com/doi/abs/10.1053/jvet.2000.7539?cookieSet=1&journalCode=vsu> which redirects to <http://www3.interscience.wiley.com/journal/119040681/abstract?Cretry=1&Sretry=0>; [online] accessed: Sep. 22, 2008 (2 pages).

Indian Standard: Automotive Vehicles—Brakes and Braking Systems (IS 11852-1:2001), Mar. 1, 2001.

Disclosed Anonymously, "Motor-Driven Surgical Stapler Improvements," Research Disclosure Database No. 526041, Published: Feb. 2008.

Van Meer et al., "A Disposable Plastic Compact Wrist for Smart Minimally Invasive Surgical Tools," LAAS/CNRS (Aug. 2005).

Breedveld et al., "A New, Easily Miniaturized Sterrable Endoscope," IEEE Engineering in Medicine and Biology Magazine (Nov./Dec. 2005).

ASTM procedure D2240-00, "Standard Test Method for Rubber Property-Durometer Hardness," (Published Aug. 2000).

ASTM procedure D2240-05, "Standard Test Method for Rubber Property-Durometer Hardness," (Published Apr. 2010).

Pitt et al., "Attachment of Hyaluronan to Metallic Surfaces," J. Biomed. Mater. Res. 68A: pp. 95-106, 2004.

Solorio et al., "Gelatin Microspheres Crosslinked with Genipin for Local Delivery of Growth Factors," J. Tissue Eng. Regen. Med. (2010), 4(7): pp. 514-523.

Biomedical Coatings, Fort Wayne Metals, Research Products Corporation, obtained online at www.fwmetals.com on Jun. 21, 2010 (1 page).

Anonymous: "Stamping (metalworking)—Wikipedia," Jun. 6, 2016, Retrieved from the Internet: URL: [https://en.wikipedia.org/w/index.php?title=Stamping_\(metalworking\)&oldid=723906245](https://en.wikipedia.org/w/index.php?title=Stamping_(metalworking)&oldid=723906245) [retrieved on May 15, 2018].

* cited by examiner

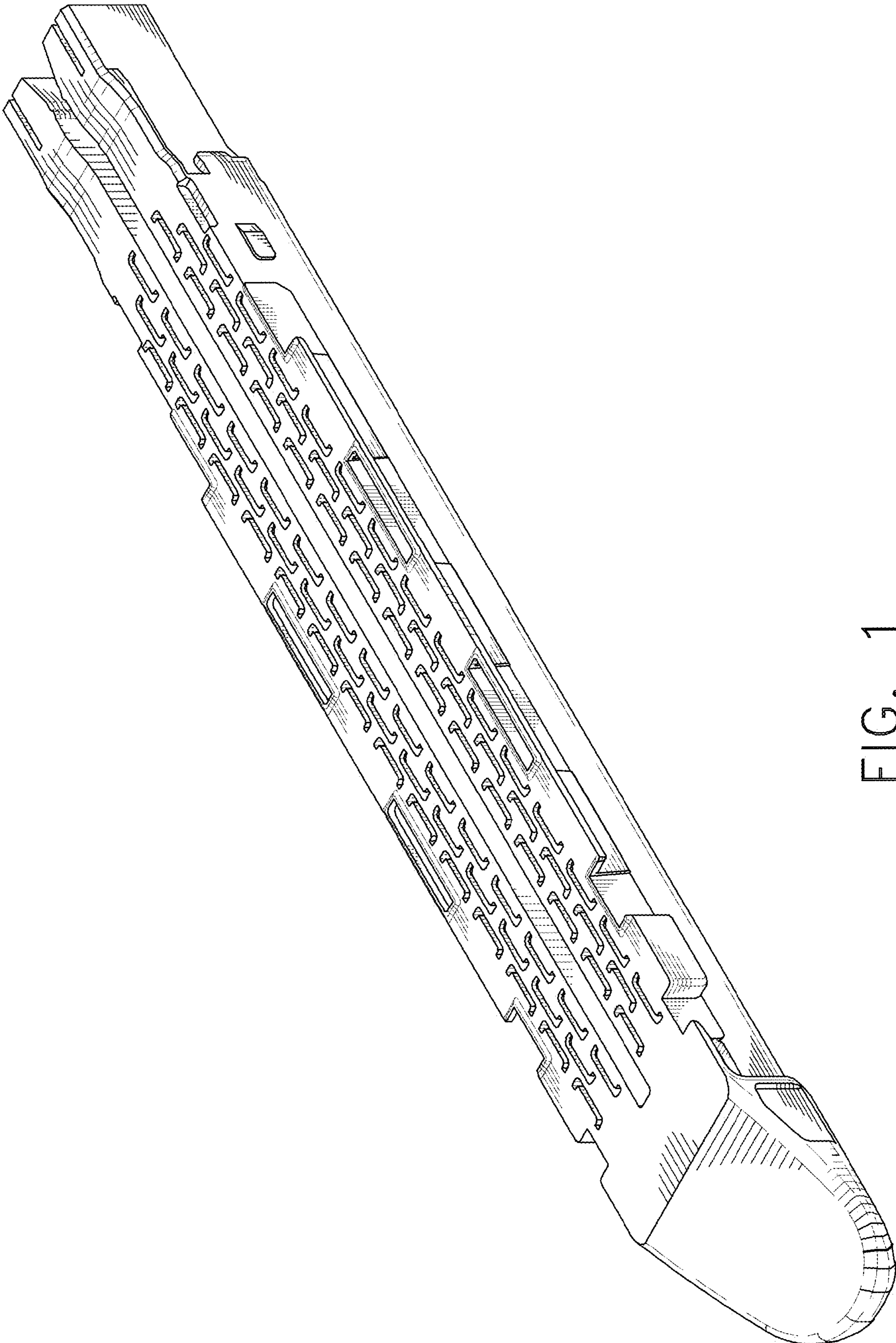

FIG. 1

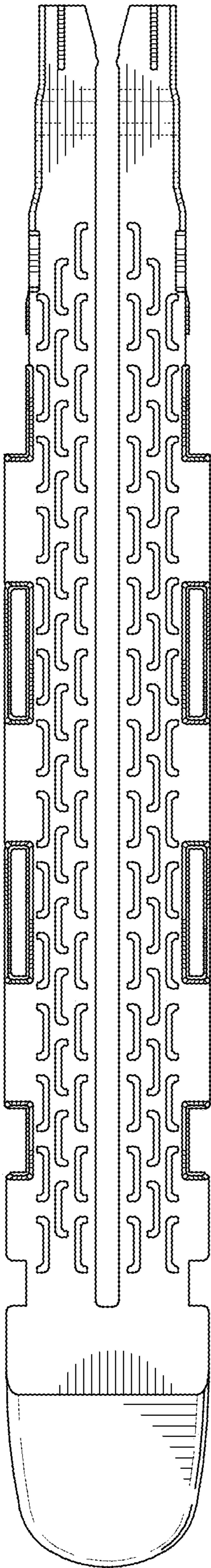

FIG. 2

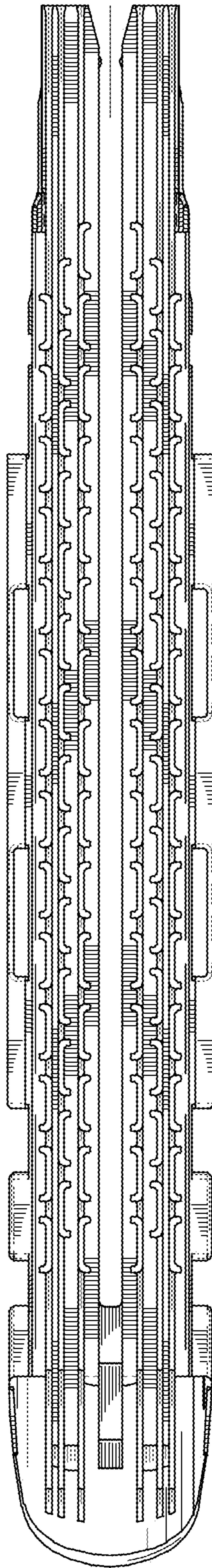

FIG. 3

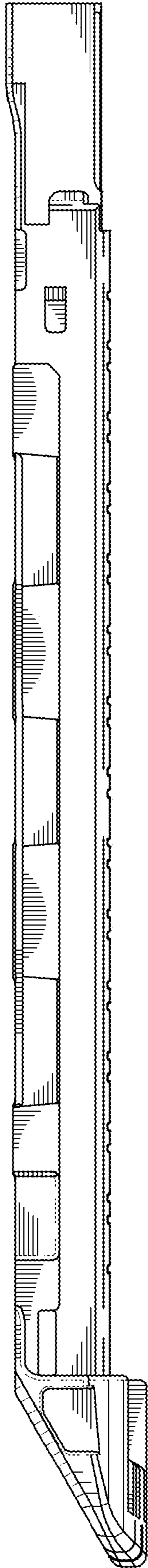

FIG. 4

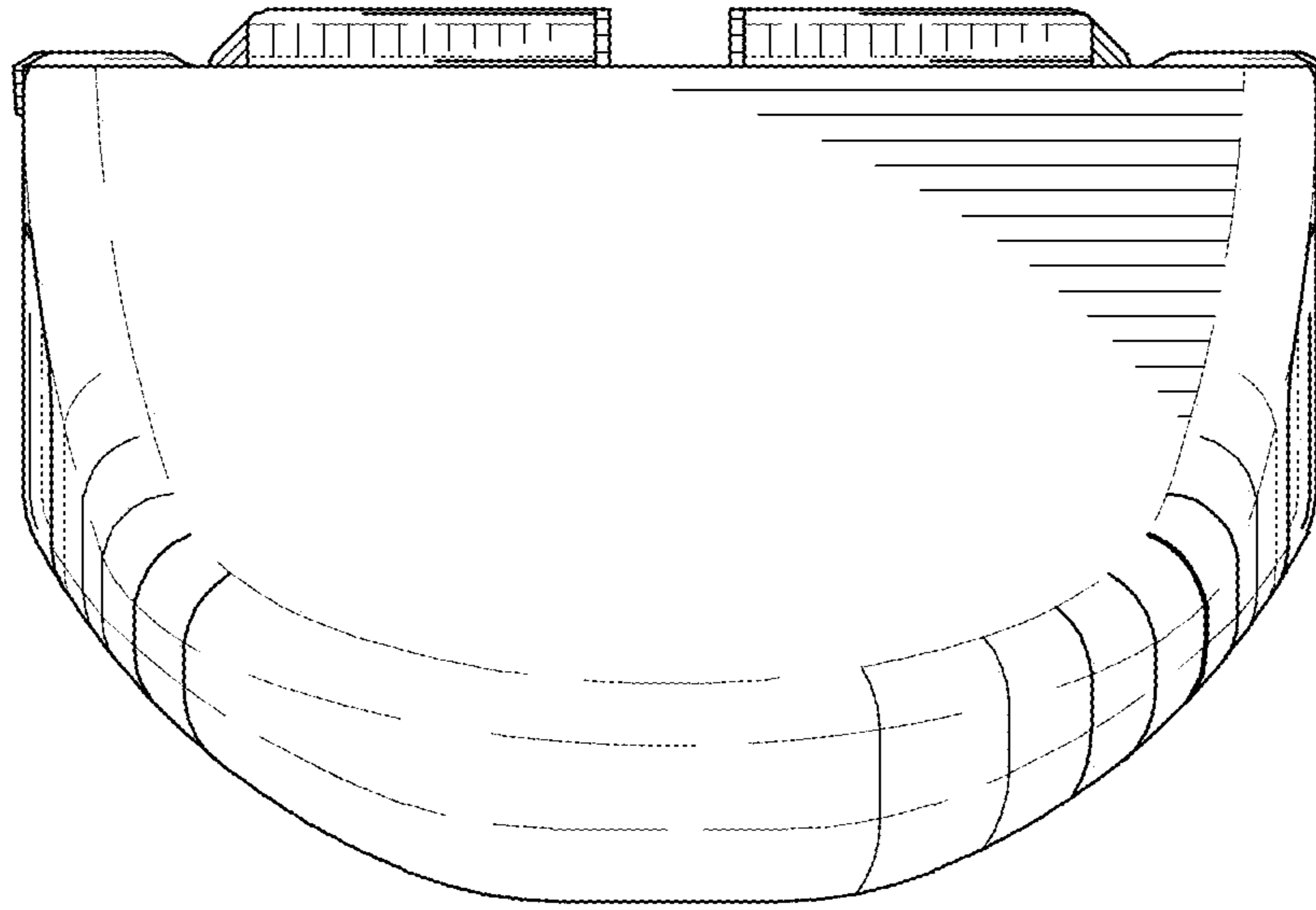

FIG. 5

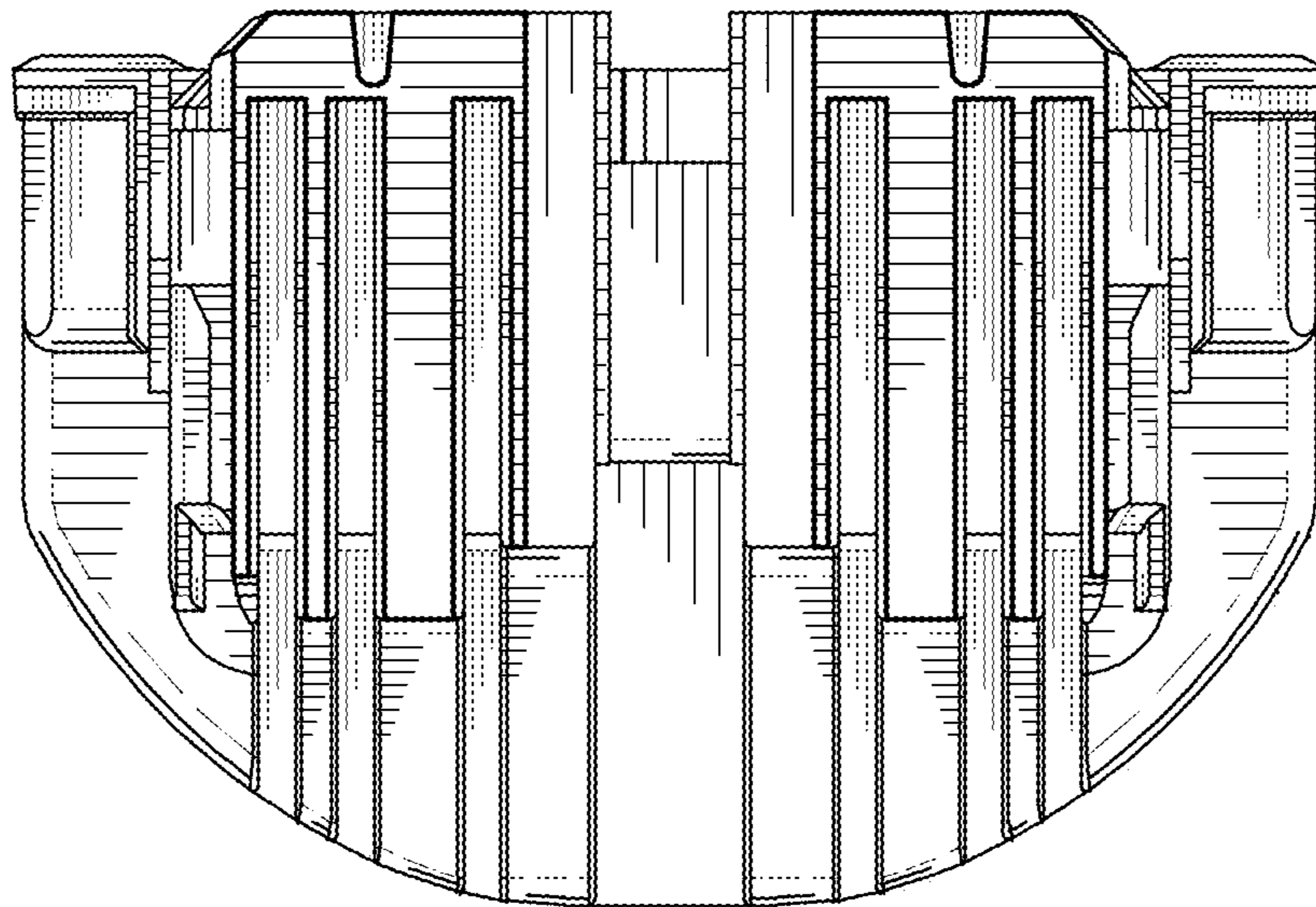

FIG. 6

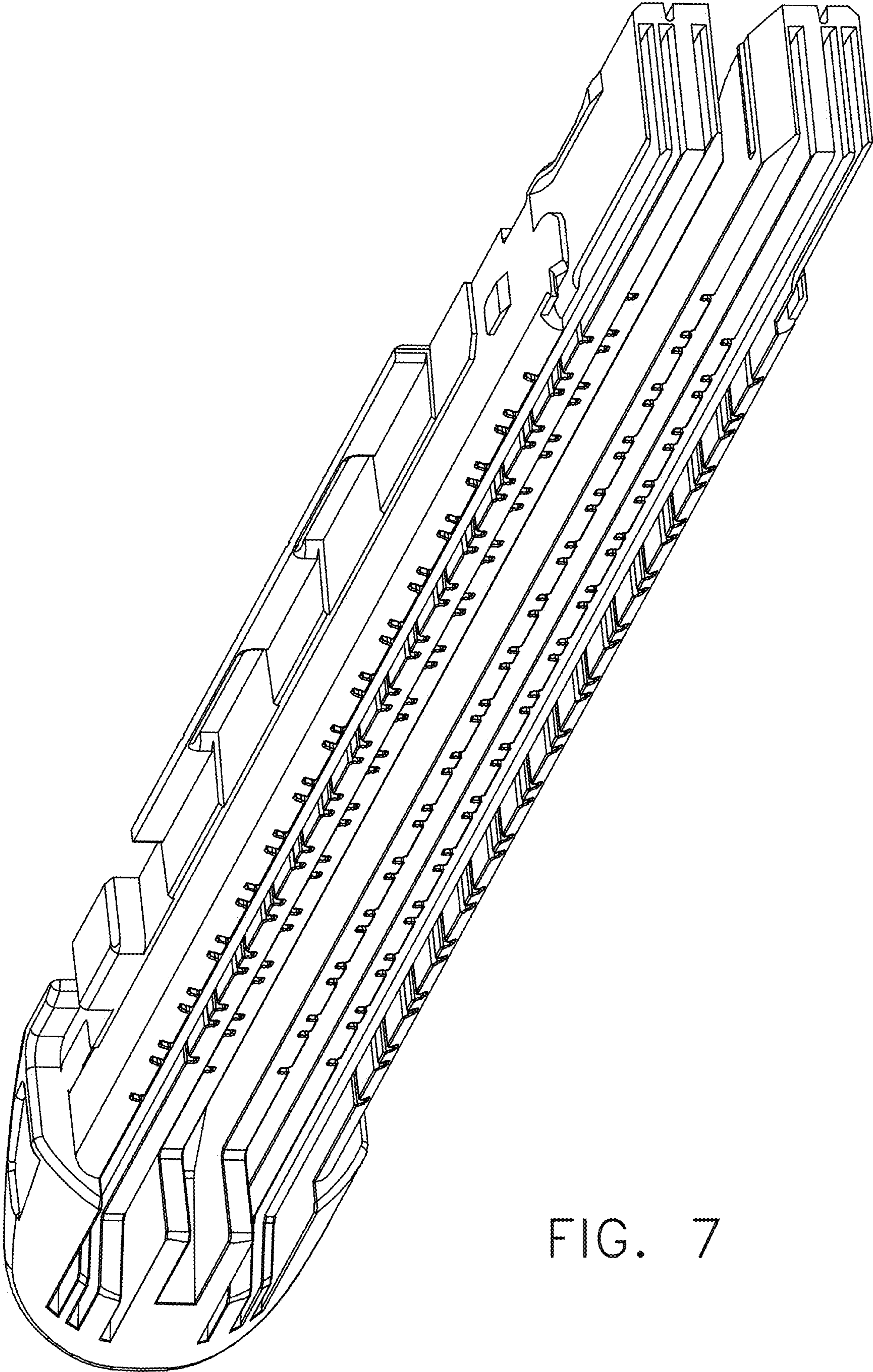

FIG. 7