



US00D895482S

(12) **United States Design Patent** (10) **Patent No.:** **US D895,482 S**
Pate (45) **Date of Patent:** **** Sep. 8, 2020**

(54) **APPAREL BUCKLE**
(71) Applicant: **Shannon Pate**, Townley, AL (US)
(72) Inventor: **Shannon Pate**, Townley, AL (US)
(**) Term: **15 Years**
(21) Appl. No.: **29/644,656**
(22) Filed: **Apr. 19, 2018**
(51) **LOC (12) Cl.** **02-07**
(52) **U.S. Cl.**
USPC **D11/212**
(58) **Field of Classification Search**
USPC D3/215, 222, 318; D8/349, 354;
D11/200, 201, 210, 212, 215, 218, 228,
D11/230, 231, 237; D22/108, 199
CPC A44B 11/04; A44B 11/08; A44B 11/24;
A44B 11/65; A41F 11/02; A41F 11/04;
Y10T 24/44197; Y10T 24/4663
See application file for complete search history.

2,172,309 A * 9/1939 Langhammer A41F 11/04
24/478
D144,290 S * 4/1946 De Woskin D11/212
D171,440 S * 2/1954 Chisholm D11/212
2,747,248 A * 5/1956 Mercer A61F 13/64
24/709.5
3,402,441 A * 9/1968 De Woskin A41F 11/04
24/487
3,406,434 A * 10/1968 Moskowitz A41F 11/04
24/490
3,408,708 A * 11/1968 Hawie A41F 11/04
24/478
D306,272 S * 2/1990 Kruger D11/212
5,353,441 A * 10/1994 Lazorchak A41D 27/085
2/240

(Continued)

Primary Examiner — Kevin K Rudzinski
Assistant Examiner — Richard Kearney
(74) *Attorney, Agent, or Firm* — Bush Intellectual
Property Law; Kenneth M. Bush

(57) **CLAIM**

I claim the ornamental design for an apparel buckle, as shown and described.

DESCRIPTION

FIG. 1 is a bottom, front, left side perspective view of an apparel buckle showing my new design;
FIG. 2 is a front elevation view thereof, the rear elevation view being identical to the front elevation view;
FIG. 3 is a top plan view thereof;
FIG. 4 is a bottom plan view thereof;
FIG. 5 is a left side elevation view thereof, the right side elevation view being identical to the left side elevation view; and,
FIG. 6 is a front elevation view thereof shown with a clothing strap and button illustrated in broken lines.
The broken lines shown in the drawings illustrate environmental structure and form no part of the claimed design.

(56) **References Cited**
U.S. PATENT DOCUMENTS

D23,645 S * 9/1894 Warner D11/212
D24,234 S * 4/1895 Hoyt D11/212
574,459 A * 1/1897 Smith A41F 11/04
24/480
748,282 A * 12/1903 Jenkin A41F 15/02
24/369
1,354,095 A * 9/1920 Evans A41F 11/04
24/701
RE15,877 E * 7/1924 Hazelton A41F 11/04
24/475
2,012,707 A * 8/1935 Bodensiek A41F 11/02
24/473
2,015,863 A * 10/1935 Mosgrove A44B 11/04
24/186
2,066,957 A * 1/1937 Wratschko A41F 11/04
24/346

1 Claim, 3 Drawing Sheets

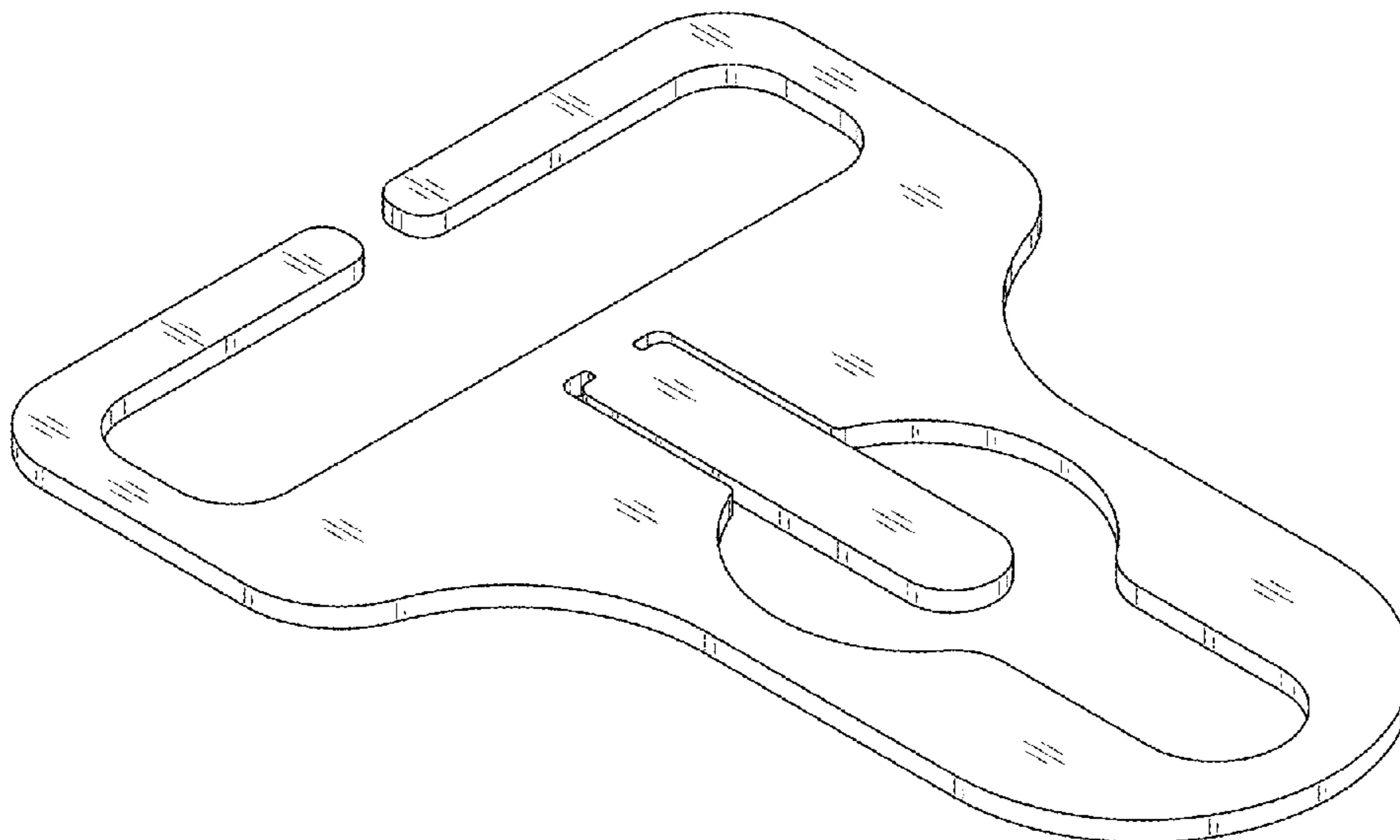

(56)

References Cited

U.S. PATENT DOCUMENTS

5,772,371 A * 6/1998 Ackerman A44B 11/04
24/129 R
D533,807 S * 12/2006 English D11/212

* cited by examiner

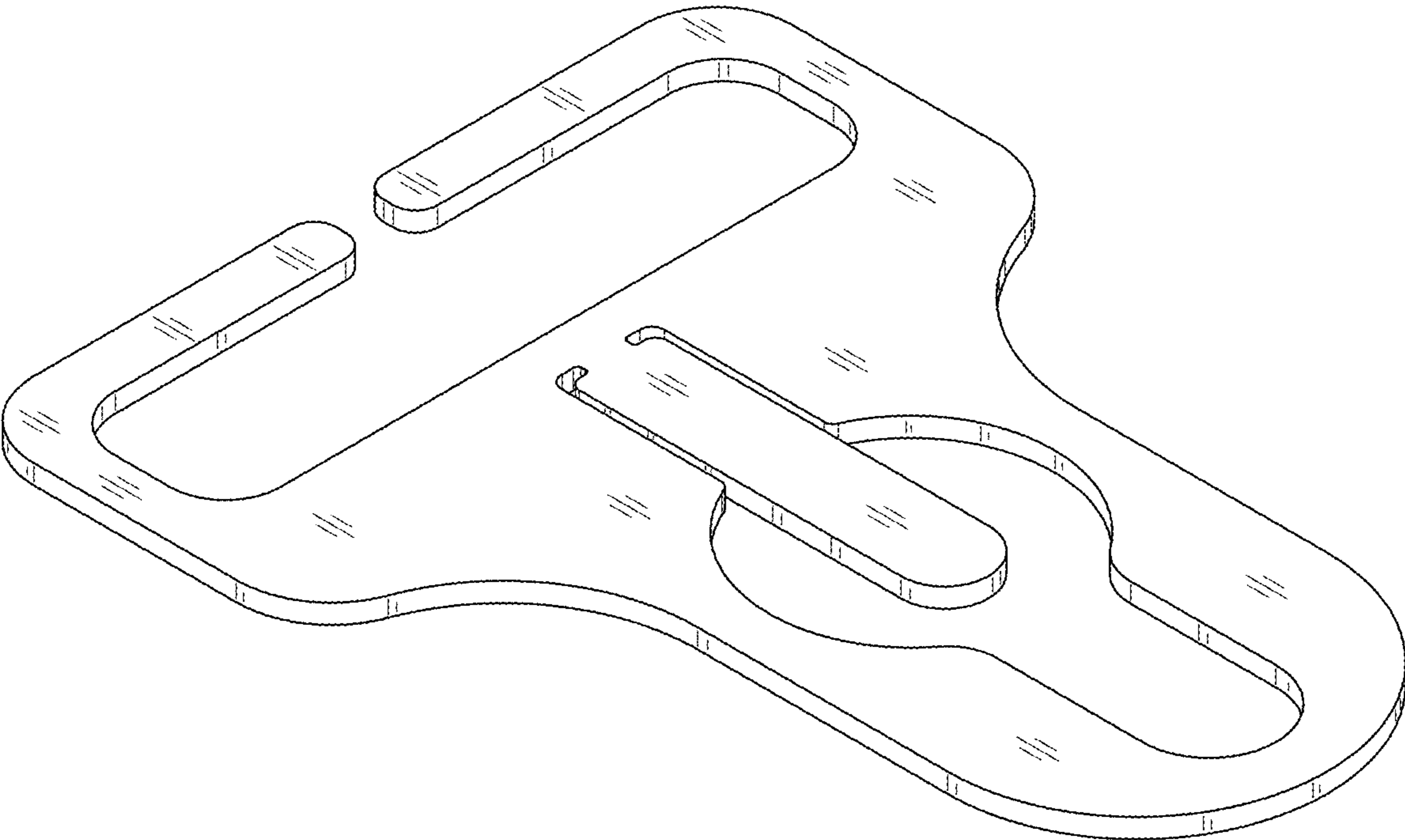

FIG. 1

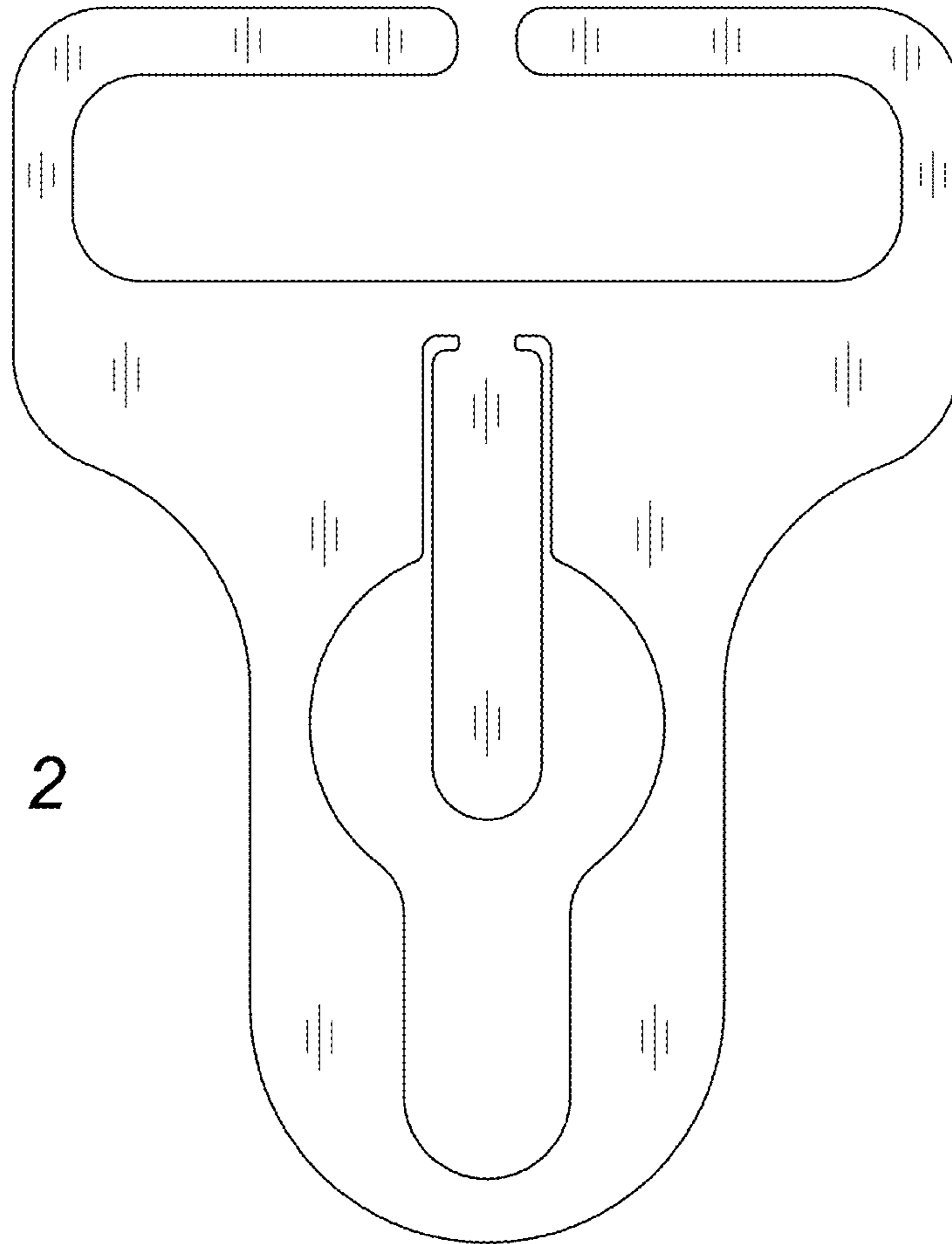

FIG. 2



FIG. 3

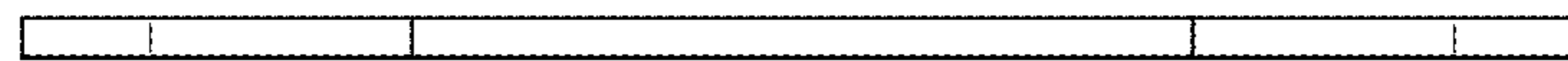

FIG. 4



FIG. 5

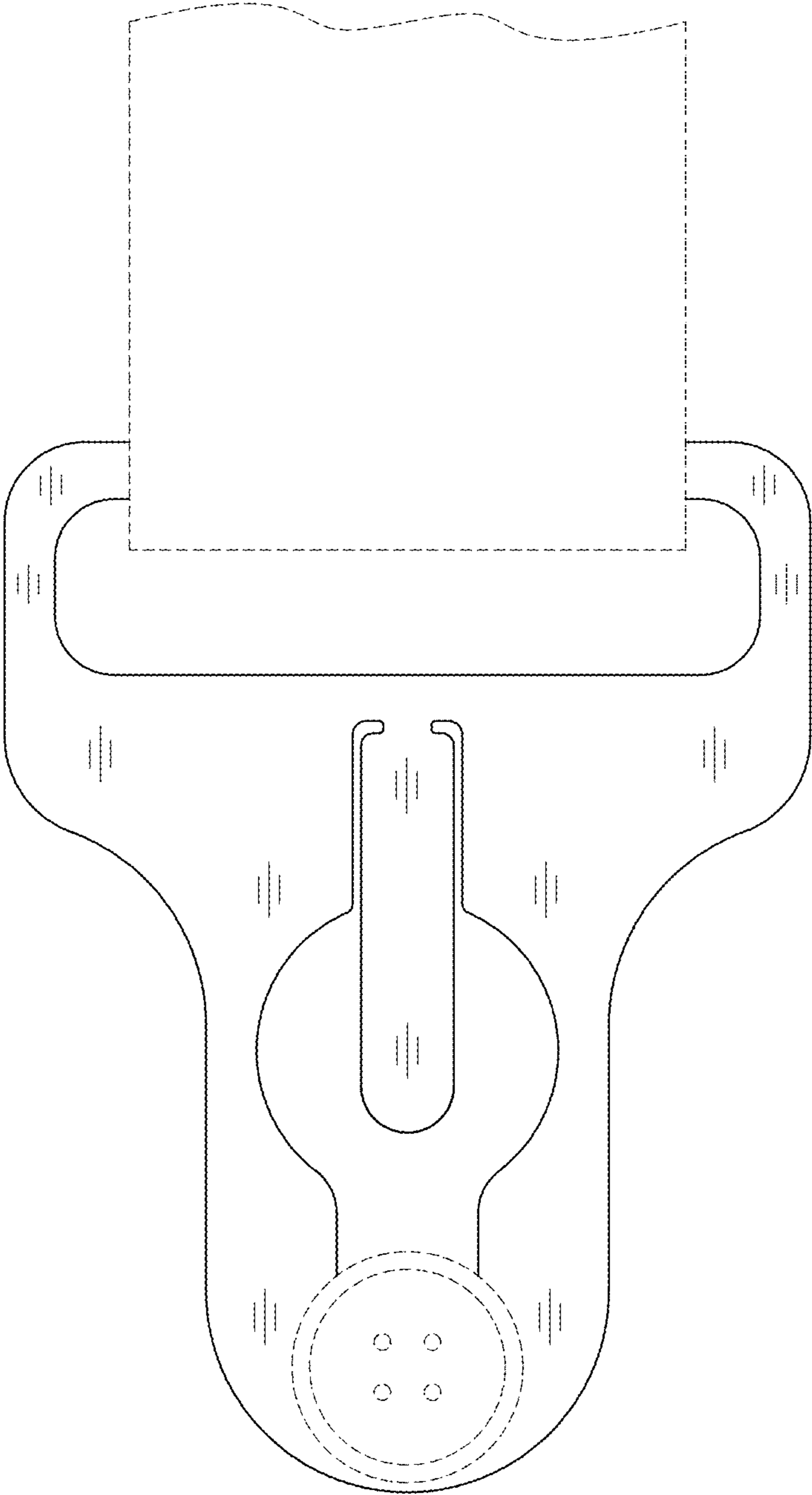

FIG. 6