

US00D895157S

(12) **United States Design Patent** (10) **Patent No.:** **US D895,157 S**
Oldroyd et al. (45) **Date of Patent:** **** Sep. 1, 2020**

(54) **LONGITUDINAL BEAM**

FOREIGN PATENT DOCUMENTS

(71) Applicant: **ISOTRUSS INDUSTRIES LLC**,
Provo, UT (US)

FR 1377290 A 11/1964
GB 1251343 10/1971

(Continued)

(72) Inventors: **Jordan W. Oldroyd**, Provo, UT (US);
Jonathan J. Curtis, Provo, UT (US);
Carter J. Smith, Orem, UT (US);
Nathan D. Rich, Orem, UT (US)

OTHER PUBLICATIONS

37th AIAA/ASME/ASCE/AHS/ASC Structures, Structural Dynam-
ics, and Materials Conference, Apr. 15-17, 1996, Salt Lake City,
Utah, U.S.A., pp. 1868-1873.

(Continued)

(73) Assignee: **IsoTruss Indsutries LLC**, Provo, UT
(US)

(**) Term: **15 Years**

Primary Examiner — Samantha Q Lawrence

(21) Appl. No.: **29/639,490**

(74) *Attorney, Agent, or Firm* — Brake Hughes
Bellermann LLP

(22) Filed: **Mar. 6, 2018**

(51) **LOC (12) Cl.** **25-01**

(57) **CLAIM**

(52) **U.S. Cl.**
USPC **D25/128**

What is claimed is an ornamental design for a longitudinal
beam, as shown and described herein.

(58) **Field of Classification Search**
USPC D25/126, 127, 128, 129, 130, 131, 132,
D25/134, 135, 136

DESCRIPTION

CPC .. B64G 9/00; B64G 1/222; E04B 1/19; E04B
2001/1927; E04B 2001/1984; E04B
2001/1987; E04B 1/1903; E04B 1/1906;
E04B 1/3441; E04B 2001/1933; E04B
2001/1936; E04B 2001/1957; E04B
2001/1963; E04B 2001/1972; E04B
2001/1975; B21F 27/12; B21F 27/128;
B21F 27/20; B21F 3/02; E04C 2/36;
E04C 2/365; E04C 3/291; E04C 3/28;
E04C

(Continued)

FIG. 1 is a partial side view of a longitudinal beam;
FIG. 2 is a cross-sectional view thereof cut along line 1-1 of
FIG. 1;
FIG. 3 is a perspective view of the section of the longitudinal
beam shown in FIG. 1;
FIG. 4 is another perspective view of a section of the
longitudinal beam shown in FIG. 1;
FIG. 5 is a zoomed-in view of a portion of the longitudinal
beam shown in FIG. 1, which illustrates claimed portions at
intersections of helicals with longitudinal members; and,
FIG. 6 is a zoomed-in view of a portion of the longitudinal
beam shown in FIG. 1, which illustrates claimed portions at
intersections of helicals.

The broken lines illustrate portions of a longitudinal beam
that form no part of the claimed design. The dot-dash lines
illustrate boundaries that form no part of the claimed design.

(56) **References Cited**

U.S. PATENT DOCUMENTS

1,465,307 A 8/1923 Keogan
1,613,788 A 1/1927 Dawson et al.

(Continued)

1 Claim, 5 Drawing Sheets

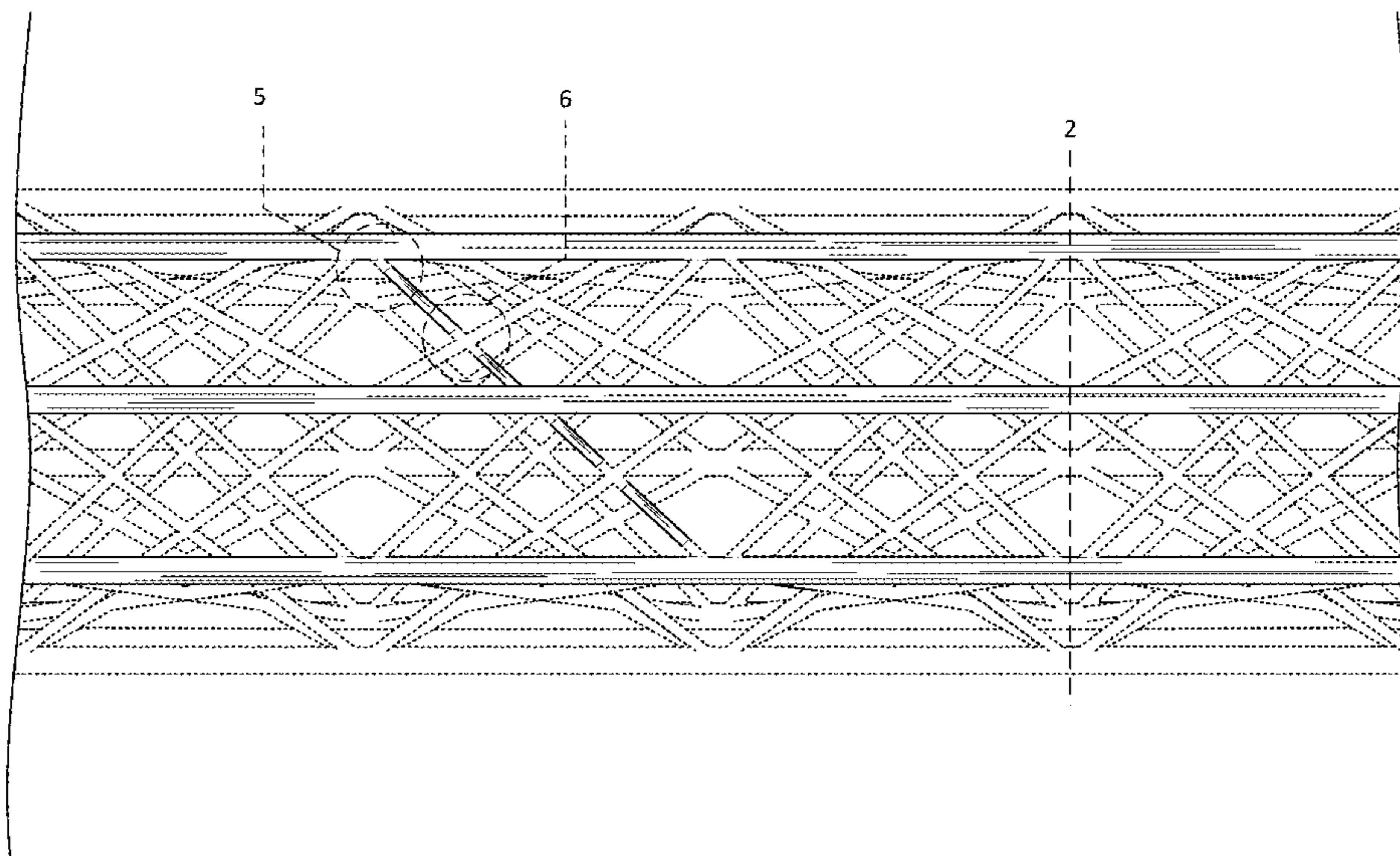

(58) **Field of Classification Search**

CPC 3/285; E04C 3/29; E04C 3/08; E04C
2003/0447; E04C 2203/0495; E04C
2003/0443; E04H 12/182; E04H 12/10;
E04H 12/02; E04H 12/18; E04H 12/185;
E04H 12/2223; B29C 370/24; B29C
70/54; B29K 2307/04; B29K 2063/00;
B29L 2031/10

See application file for complete search history.

(56) **References Cited**

U.S. PATENT DOCUMENTS

1,798,064 A	3/1931	Chorlton et al.
1,922,269 A	8/1933	Wickwire, Jr.
2,106,674 A	1/1938	Busch
2,158,266 A	5/1939	Aldrich
2,362,688 A	11/1944	Dunn
2,879,687 A	3/1959	Leimbach et al.
2,931,467 A	4/1960	Fentiman
2,941,440 A	6/1960	Scanlon
3,007,497 A	11/1961	Shobert
3,062,336 A	11/1962	Baxter
3,495,687 A	2/1970	Shirley, Jr. et al.
3,496,687 A	2/1970	Greenberg et al.
3,501,880 A	3/1970	Bosch
3,705,473 A	12/1972	Yeffal-Rueda
3,798,864 A	3/1974	Georgii
3,800,414 A	4/1974	Shattes et al.
3,970,116 A	7/1976	Takada et al.
3,992,118 A	11/1976	Siegers
4,077,828 A	3/1978	Strom
4,109,038 A	8/1978	Hayashi et al.
4,137,354 A	1/1979	Mayes, Jr. et al.
4,241,117 A	12/1980	Figge
4,253,284 A	3/1981	Bliss
4,260,143 A	4/1981	Kliger
4,321,854 A	3/1982	Foote et al.
4,337,560 A	7/1982	Slysh
4,347,287 A	8/1982	Lewis et al.
4,366,658 A	1/1983	Maistre
4,380,483 A	4/1983	Kliger
4,471,548 A	9/1984	Goudie
4,473,217 A	9/1984	Hashimoto
4,475,232 A	10/1984	Shaw
4,475,323 A	10/1984	Schwartzberg et al.
4,494,436 A	1/1985	Kruesi
4,539,786 A	9/1985	Nelson
4,557,097 A	12/1985	Mikulas, Jr. et al.
4,655,022 A	4/1987	Natori
4,686,134 A	8/1987	Ono
4,722,162 A	2/1988	Wilensky
4,734,146 A	3/1988	Halcomb et al.
4,786,341 A	11/1988	Kobatake et al.
4,803,824 A	2/1989	Coppa
4,912,889 A	4/1990	Palumbo
4,916,997 A	4/1990	Spain
4,951,440 A	8/1990	Staeger
4,986,863 A	1/1991	Denoel et al.
5,003,736 A	4/1991	Okazaki et al.
5,016,516 A	5/1991	Aldrich et al.
5,048,441 A	9/1991	Quigley
5,152,326 A	10/1992	Vohringer
5,184,444 A	2/1993	Warden
5,197,254 A	3/1993	Smith
5,320,696 A	6/1994	McConnell et al.
5,356,234 A	10/1994	Vangool
5,388,538 A	2/1995	Chekroune et al.
5,463,970 A	11/1995	Hartlmeier et al.
5,505,035 A	4/1996	Lalvani
5,556,677 A	9/1996	Quigley et al.
5,651,228 A	7/1997	Zeigler
5,846,364 A	12/1998	Policelli
D408,665 S *	4/1999	Von Gunten D25/69
5,921,048 A	7/1999	Francom et al.
5,962,150 A	10/1999	Priluck

5,985,304 A	11/1999	Van Voris et al.
6,076,324 A	6/2000	Daily et al.
6,264,684 B1	7/2001	Banas et al.
6,321,502 B1	11/2001	Castano
6,431,497 B1	8/2002	Hoyt et al.
6,439,096 B1	8/2002	Mungalov et al.
6,647,852 B1	11/2003	Freitas et al.
6,910,308 B2	6/2005	Cadogan et al.
7,132,027 B2	11/2006	Jensen
7,155,872 B2	1/2007	Francom
7,318,303 B1	1/2008	Kling
D604,452 S *	11/2009	Smith D26/118
7,694,465 B2	4/2010	Pryor
7,694,486 B2	4/2010	Murphy et al.
D624,201 S *	9/2010	Hendricks D25/100
8,042,305 B2	10/2011	Pryor et al.
8,320,727 B1	11/2012	Jacobsen et al.
D672,478 S *	12/2012	Hendricks D25/100
8,444,900 B2	5/2013	Wilson et al.
D697,833 S *	1/2014	Garcia D11/146
8,621,822 B2	1/2014	Brockwell
8,745,958 B2	6/2014	Kang et al.
D714,066 S *	9/2014	Thuma D5/99
D722,180 S *	2/2015	Gowrie D25/22
9,116,428 B1	8/2015	Jacobsen et al.
D753,844 S *	4/2016	Gervais D25/100
D759,885 S *	6/2016	Nishimoto D26/118
D783,878 S *	4/2017	Lava D26/81
10,557,267 B2	2/2020	Oldroyd et al.
2002/0081936 A1	6/2002	Snelson
2002/0124518 A1	9/2002	Warren et al.
2004/0247866 A1	12/2004	Jensen
2005/0115186 A1	6/2005	Jensen et al.
2007/0095012 A1	5/2007	Kang et al.
2007/0151202 A1	7/2007	Cox et al.
2010/0071300 A1	3/2010	Lee et al.
2011/0117315 A1	5/2011	Kang et al.
2012/0151868 A1	6/2012	Kang et al.
2012/0225237 A1	9/2012	Brockwell
2013/0080123 A1	3/2013	Webbink et al.
2013/0167462 A1	7/2013	Wilson et al.
2013/0243989 A1	9/2013	Ridges et al.
2013/0276308 A1	10/2013	Kang et al.
2013/0322955 A1	12/2013	Ma
2014/0182232 A1	7/2014	Holt
2014/0288650 A1	9/2014	Hunt
2014/0302261 A1	10/2014	Cheung et al.
2017/0100855 A1	4/2017	Taylor
2017/0173894 A1	6/2017	Konrad et al.
2017/0306923 A1	10/2017	Berthilsson
2018/0251979 A1	9/2018	Oldroyd et al.
2018/0251980 A1	9/2018	Oldroyd et al.

FOREIGN PATENT DOCUMENTS

GB	2049613 A	12/1980
GB	2164674 A	3/1986
JP	59-55946 A	3/1984
JP	S6215695 B2	4/1987
WO	98/4556 A1	10/1998
WO	02/10535 A2	2/2002

OTHER PUBLICATIONS

Asay: "Bending Behavior of Carbon/Epoxy Composite IsoBeam Structures," Thesis, Mar. 8, 2016, 257 pages.

Hinds: "Shear-Dominated Bending Behavior of Carbon/Epoxy Composite Lattice IsoBeam Structures"; Thesis, Apr. 11, 2016, 161 pages.

Swanson, A. D. et al., "Zero-Gravity Dynamics of Space Structures in Parabolic Aircraft Flight" flight dynamics laboratory, air force Wright research and development center ,Wright-Patterson Air Force Base, Ohio, pp. 952-965 presented at the First Joint US/ Japan Conference on Adaptive Structures Nov. 13-15, 1990.

AGARD Conference Proceedings 531, Smart Structures for Aircraft and Spacecraft, Oct. 5-7, 1992, Lindau, Germany, 389 pages.

(56)

References Cited

OTHER PUBLICATIONS

Wada et al.: First Joint U.S./Japan Conference on Adaptive Structures, Nov. 13-15, 1990, Maui, Hawaii, U.S.A., Technomic Publishing Co., Inc.

Matsuzaki et al.: Second Joint Japan/U.S. Conference on Adaptive Structures, Nov. 12-14, 1991, Nagoya, Japan, Technomic Publishing Co., Inc., 21 pages.

Allen, J. J. et al., "The Sandia Structural Control Experiments" Sandia National Laboratories, Albuquerque, New Mexico, pp. 928-951 presented at the First Joint US/ Japan Conference on Adaptive Structures Nov. 13-15, 1990.

Anderson, W.W. et al., The NASA-LaRC Controls-Structure Interaction Technology Program Guidance and Control Division, NASA, Hampton, Virginia, pp. 15-31, presented at the Second Joint US/ Japan Conference on Adaptive Structures Nov. 12-14, 1991.

Beer, F. et al. "Space Trusses"; Vector Mechanics for Engineers Statics Third Edition, pp. 222-228, 1977.

Betti, F. et al., "On Possible Applications of Smart Structures to Control of Space Systems" AGARD Conference proceedings 531 Smart Structures for Aircraft and Spacecraft held in Germany, Oct. 1992, pp. 26-1 to 26-14.

Breitbach, E. J., "Research Status on Adaptive Structures in Europe" Institute of Aeroelasticity, Goettingen, Germany, pp. 32-48, presented at the Second Joint US/ Japan Conference on Adaptive Structures Nov. 12-14, 1991.

Bronowicki, A.J. et al., "ACESA Structural Control System Design" TRW Space and Technology Group, Redondo Beach, California, pp. 373-401 presented at the First Joint US/ Japan Conference on Adaptive Structures Nov. 13-15, 1990.

Chen, G.S. et al., "On an Adaptive Truss Manipulator Space Crane Concept" Jet Propulsion Laboratory, California Institute of Technology, Pasadena, California, pp. 726-742, presented at the First Joint US/ Japan Conference on Adaptive Structures Nov. 13-15, 1990.

Crawley, Edward et al., "Intelligent Structures a Technology Overview and Assessment": AGARD Conference proceedings 531 Smart Structures for Aircraft and Spacecraft held in Germany, Oct. 1992, Space Engineering Research Center, MIT, pp. 6-1 to 6-16, Cambridge, Massachusetts, USA.

Darooka et al., "Advanced Space Structure Concepts and Their Development", American Institute of Aeronautics and Astronautics, Structures, Structural Dynamics, and Materials Conference and Exhibit, 42nd Seattle Washington, Apr. 16-19, 2001, pp. 1-10.

Das, Alok et al., "Adaptive Structures for Spacecraft a USAF Perspective" AGARD Conference proceedings 531 Smart Structures for Aircraft and Spacecraft held in Germany, Oct. 1992 pp. 3-1 to Mar. 3, 2013.

Das, SK et al., "A Mathematical Basis for the Design and Design Optimization of Adaptive Trusses in Precision Control" Duke University, Durham North Carolina, pp. 660-690 presented at the First Joint US/ Japan Conference on Adaptive Structures Nov. 13-15, 1990.

D'Eleuterio, G. M. T., "Articulatory Dynamics of Variable-Geometry Truss Structures" Institute for Aerospace Studies, University of Toronto, Downsview, Ontario, Canada, pp. 621-640, presented at the Second Joint US/ Japan Conference on Adaptive Structures Nov. 12-14, 1991.

Fanson, J.L. et al., "Damping and Structural Control of the JPL Phase 0 Testbed Structure" Jet Propulsion Laboratory California Institute of Technology, Pasadena, California pp. 510-524 presented at the First Joint US/ Japan Conference on Adaptive Structures Nov. 13-15, 1990.

Fiber Innovations, Inc. "Braided Composite Structures", 6 pages.

Fiber Innovations, Inc. Brochure, 4 pages.

Fisher, S., "Real-Time Modifications of an Orbiting Spacecraft to Excite Vibrations Observed by a Ground-Based Laser Radar" Naval Research Laboratory, Washington, D.C., pp. 479-492, presented at the Second Joint US/ Japan Conference on Adaptive Structures Nov. 12-14, 1991.

Hibbeler, RC: "Space Trusses" Engineering Mechanics Statics, Chapter 6, Seventh Edition, pp. 267-270, Prentice-Hall, Englewood Cliffs, New Jersey, 1995.

Hughes, P.C., "Trussarm-A Variable-Geometry-Truss Manipulator" University of Toronto, Institute for Aerospace Studies, Toronto, Canada, pp. 715-725 presented at the First Joint US/ Japan Conference on Adaptive Structures Nov. 13-15, 1990.

Jensen, D. W. et al., "Dynamic Characterization of a Composite Lattice Structure with an Integrated Fiber-Optic Strain Sensor" The Pennsylvania State University, Department of Aerospace Engineering, University Park, Pennsylvania, pp. 328-845, presented at the First Joint US/ Japan Conference on Adaptive Structures Nov. 13-15, 1990.

Jensen, D. W. et al. "On the Structural Efficiency of Three-Dimensional Isogrid Designs"; 37thAIAA/ASME/ASCE/AHS/ASC Structures, Structural Dynamics, and Materials Conference; Apr. 15-17, 1996.

Jensen, W. D. et al., "Validation of Active Strain Measurements in Composites Using Mach-Zehnder Interferometry with Embedded Optical Fibers" The Pennsylvania State University, Department of Aerospace Engineering, University Park, Pennsylvania, pp. 771-788, presented at the Second Joint US/ Japan Conference on Adaptive Structures Nov. 12-14, 1991.

Kuo, C.P. et al., "Optimal Actuator Placement on an Active Reflector Using a Modified Simulated Annealing Technique" Applied Mechanics Technologies Section, Jet Propulsion Laboratory, California Institute of Technology, Pasadena, California, pp. 1056-1068 presented at the First Joint US/ Japan Conference on Adaptive Structures Nov. 13-15, 1990.

Kuwao, F. et al., "Quasi-Static Shape Estimation and Control of Adaptive Truss Structures Using Internal Displacement Structures" Applied mechanics Technologies Section, Jet Propulsion Laboratory, California Institute of Technology, Pasadena, California, pp. 375-392, presented at the Second Joint US/ Japan Conference on Adaptive Structures Nov. 12-14, 1991.

Larson, L. B. et al., "An Experimental 10-Meter Space Truss with Tendon Control" School of Civil and Environmental Engineering, Cornell University Ithaca, New York, pp. 227-244, presented at the Second Joint US/ Japan Conference on Adaptive Structures Nov. 12-14, 1991.

Lawrence, C.R. et al., "Active Member Vibration Control Experiment in a KC-135 Reduced Gravity Environment" Jet Propulsion Laboratory, California Institute of Technology, Pasadena, California, pp. 987-1003 presented at the First Joint US/ Japan Conference on Adaptive Structures Nov. 13-15, 1990.

Macleon, B.J. et al., "Development of a Shape Memory Material Actuator for Adaptive Truss Applications" Materials and Structures Group Research & Technology, Martin Marietta Space Systems Denver, Colorado, pp. 1038-1055 presented at the First Joint US/ Japan Conference on Adaptive Structures Nov. 13-15, 1990.

Matsuzaki, Y. et al., "Application of Fuzzy Control to Computer Simulation of Tracking and Rendezvous Test for Docking of an Adaptive Space Structure" Department of Aerospace Engineering, Nagoya University, Chikusa, Nagoya, Japan, pp. 641-652, presented at the Second Joint US/ Japan Conference on Adaptive Structures Nov. 12-14, 1991.

Matsuzaki, Y. et al., "Application of Fuzzy Control to Tracking for Docking Operation of An Adaptive Space Structure" Department of Aerospace Engineering, Nagoya university, Chikusa, Nagoya Japan, pp. 792-806 presented at the First Joint US/ Japan Conference on Adaptive Structures Nov. 13-15, 1990.

Miura, K. et al., "Aerospace Research Status on Adaptive Structures in Japan" Institute of Space and Astronautical Sciences, Yoshinodai, Sagamihara, Japan, pp. 3-14, presented at the Second Joint US/ Japan Conference on Adaptive Structures Nov. 12-14, 1991.

Mobrem, M. et al., "Control Design of Space Station Mobile Transporter with Multiple Constraints" Astro Aerospace corporation, Carpinteria, California pp. 87-116 presented at the First Joint US/ Japan Conference on Adaptive Structures Nov. 13-15, 1990.

Modi, V.J. et al., "Formulation for a Class of Adaptive Structures with Applications" Department of Mechanical Engineering, The University of British Columbia, Vancouver, British Columbia, Canada,

(56)

References Cited

OTHER PUBLICATIONS

pp. 92-110, presented at the Second Joint US/ Japan Conference on Adaptive Structures Nov. 12-14, 1991.

Murotsu, Y. et al., "Optical Configuration Control of an Intelligent Truss Structure" Department of Aeronautical Engineering, College of Engineering, University of Osaka Prefecture, Sakai, Osaka Japan, pp. 157-175 presented at the First Joint US/ Japan Conference on Adaptive Structures Nov. 13-15, 1990.

Murotsu, Y. et al., "Some Approaches to the Optimal Adaptive Geometries of Intelligent Truss Structures" University of Osaka Prefecture, Sakai, Osaka, Japan, pp. 743-771, presented at the First Joint US/ Japan Conference on Adaptive Structures Nov. 13-15, 1990.

Murotsu, Y. et al., "PD-Impedance Control of Docking Mechanism Composed of Intelligent Adaptive Structure" Department of Aeronautical Engineering, College of Engineering, University of Osaka Prefecture, Sakai, Osaka, Japan, pp. 653-669, presented at the Second Joint US/ Japan Conference on Adaptive Structures Nov. 12-14, 1991.

Naccarato, F. et al., "Redundancy Resolution in Variable-Geometry Truss Manipulators Using Reference Shape Curves" Institute for Aerospace Studies, University of Toronto, Downsview, Ontario, Canada, pp. 539-555, presented at the Second Joint US/ Japan Conference on Adaptive Structures Nov. 12-14, 1991.

Natori, M.C. et al., "Application of Adaptive Structure Concepts to Construction of Space Systems in Orbit-Concepts and Formulation" Institute of Space and Astronautical Science Sagami, Japan pp. 77-91, presented at the Second Joint US/ Japan Conference on Adaptive Structures Nov. 12-14, 1991.

Pai, S.S. et al., "Probabilistic Structural Analysis of Adaptive/Smart/ Intelligent Space Structures" National Aeronautics and Space Administration, Lewis Research Center, Cleveland, Ohio, pp. 419-433, presented at the Second Joint US/ Japan Conference on Adaptive Structures Nov. 12-14, 1991.

Seguchi, Y., "Criteria-Oriented Configuration Control of Adaptive Structure and its Modular Neural Network Representation" Department of Mechanical Engineering, Osaka University Toyonaka, Osaka Japan, pp. 402-421 presented at the First Joint US/ Japan Conference on Adaptive Structures Nov. 13-15, 1990.

Shibuta, S. et al., "Adaptive Control of Space Truss Structures by Piezoelectric Actuator" National Space Development Agency of Japan Tsukuba Space Center, Ibaraki, Japan, pp. 245-262, presented at the Second Joint US/ Japan Conference on Adaptive Structures Nov. 12-14, 1991.

Sirlin, S. W. et al., "Active Structural Control for Damping Augmentation and Compensation of Thermal Distortion" Jet Propulsion Laboratory, California Institute of Technology, Pasadena, California, pp. 434-444, presented at the Second Joint US/ Japan Conference on Adaptive Structures Nov. 12-14, 1991.

Sirlin, S.W. et al., "Sizing of Active Piezoelectric Struts for Vibration Suppression on a Space-Based Interferometer" Jet Propulsion Laboratory California Institute of Technology, Pasadena, California pp. 47-63, 1991.

Stover, D., "Braiding and RTM Succeed in Aircraft Primary Structures", *Advanced Composites* May/June 1989, 4 pages.

Tabata, M. et al., "Shape Adjustment of a Flexible space Antenna Reflector": Mitsubishi Electric Corporation, Center Research Laboratory, Hyogo, Japan, pp. 393-405, presented at the Second Joint US/ Japan Conference on Adaptive Structures Nov. 12-14, 1991.

Tanaka, M. et al., "On Damping Enhancement of LSS Coupled with the Antenna Pointing System" Toshiba Corporation, Kawasaki, Japan, pp. 510-524 presented at the First Joint US/ Japan Conference on Adaptive Structures Nov. 13-15, 1990.

Tanaka, M. et al., "Stochastic Approach to Static Control of Adaptive Truss under Imperfection of Adjustable Member Lengths" Department of Mechanical Engineering, Osaka University, Osaka, Japan, pp. 406-418, presented at the Second Joint US/ Japan Conference on Adaptive Structures Nov. 12-14, 1991.

Tanaka, M. et al., Kinematics of Adaptive Truss Permitting Modal Offset (configuration and workspace reach), Osaka university, Department of Mechanical engineering, Osaka, Japan, pp. 691-714, presented at the First Joint US/ Japan conference on Adaptive Structures Nov. 13-15, 1990.

Tidwell, PH et al., "Kinematic Analysis of Generalized Adaptive Trusses" Mechanical Engineering Department, Virginia Polytechnic Institute and State University, Blacksburg, Virginia, pp. 772-791 presented at the First Joint US/ Japan Conference on Adaptive Structures Nov. 13-15, 1990.

Troidl H. et al., "Dynamic Tests on the NASA Langley CSI Evolutionary Model" AGARD Conference proceedings 531 Smart Structures for Aircraft and Spacecraft held in Germany, Oct. 1992, pp. 4-1 to 4-9.

Wada, B. K. et al., "Application of Adaptive Structures for the Control of Truss Structures" Jet Propulsion Laboratory, California Institute of Technology Pasadena, California, pp. 123-131, presented at the Second Joint US/ Japan Conference on Adaptive Structures Nov. 12-14, 1991.

Wada, Ben K. et al., "Advances in Adaptive Structures at Jet Propulsion Laboratory" AGARD Conference proceedings 531 Smart Structures for Aircraft and Spacecraft held in Germany, Oct. 1992, Applied Mechanics Technologies Section, pp. 28-1 to 28-13, Pasadena, California, USA.

Yokoi, K et al., "A Method for Solving Inverse Kinematics of Variable Structure Truss Arm with High Redundancy" Robotics Department, Mechanical Engineering Laboratory, Tsukuba, Ibaraki, Japan, pp. 606-620, presented at the Second Joint US/ Japan Conference on Adaptive Structures Nov. 12-14, 1991.

Yoshida, K et al., "COSMO-LAB Concept: A Cooperation of Space Robots and Structures" Department of Mechanical Engineering Science, Tokyo Institute of Technology, Tokyo, Japan, pp. 59-76, presented at the Second Joint US/ Japan Conference on Adaptive Structures Nov. 12-14, 1991.

U.S. Pat. No. 31,777, "Iron Masts, Steeps, &c," issued to E.S. Boynton, patented on Mar. 26, 1861, 5 pages.

Non Final Office Action for U.S. Appl. 15/913,836, dated Feb. 6, 2019, 11 pages.

* cited by examiner

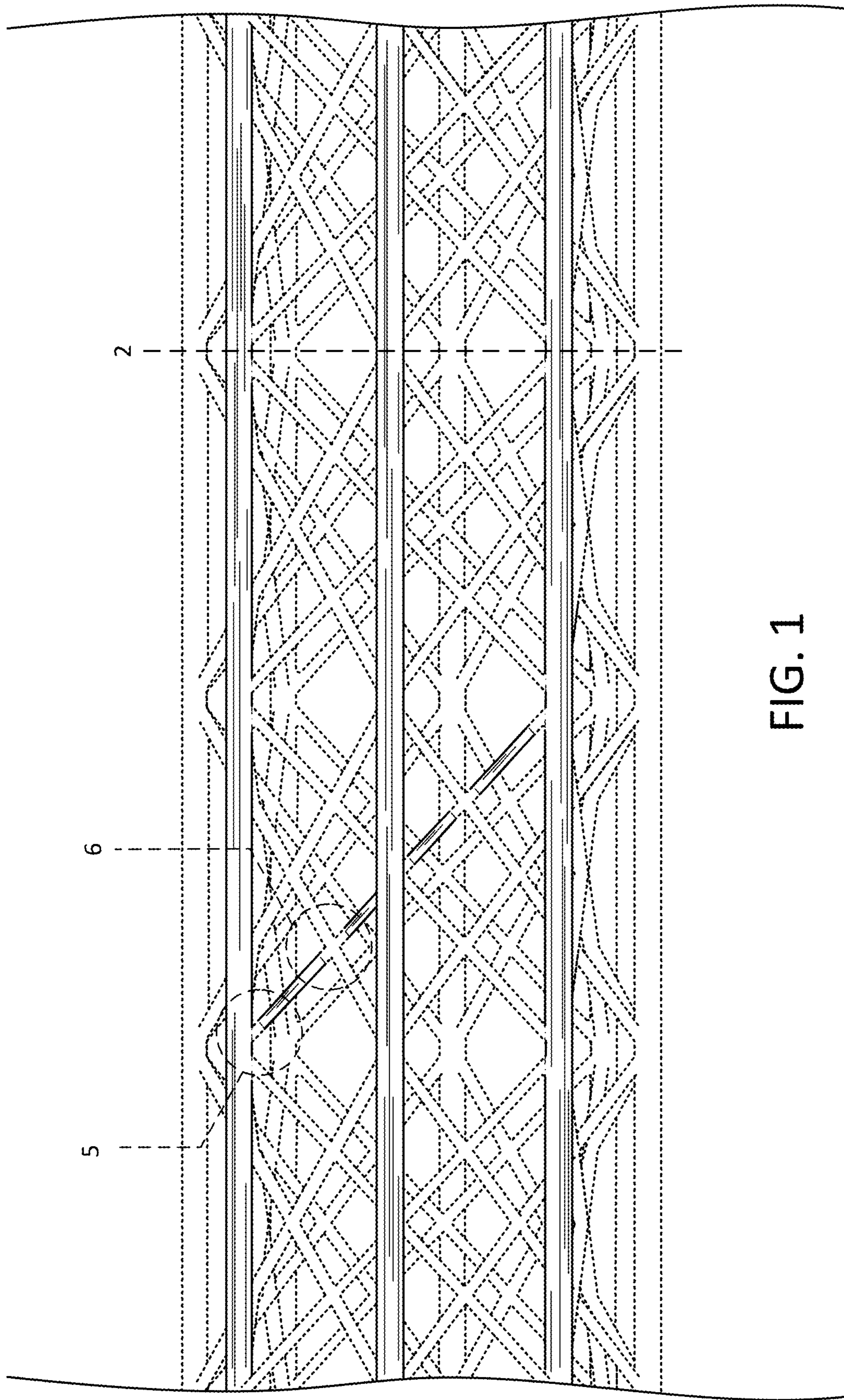

FIG. 1

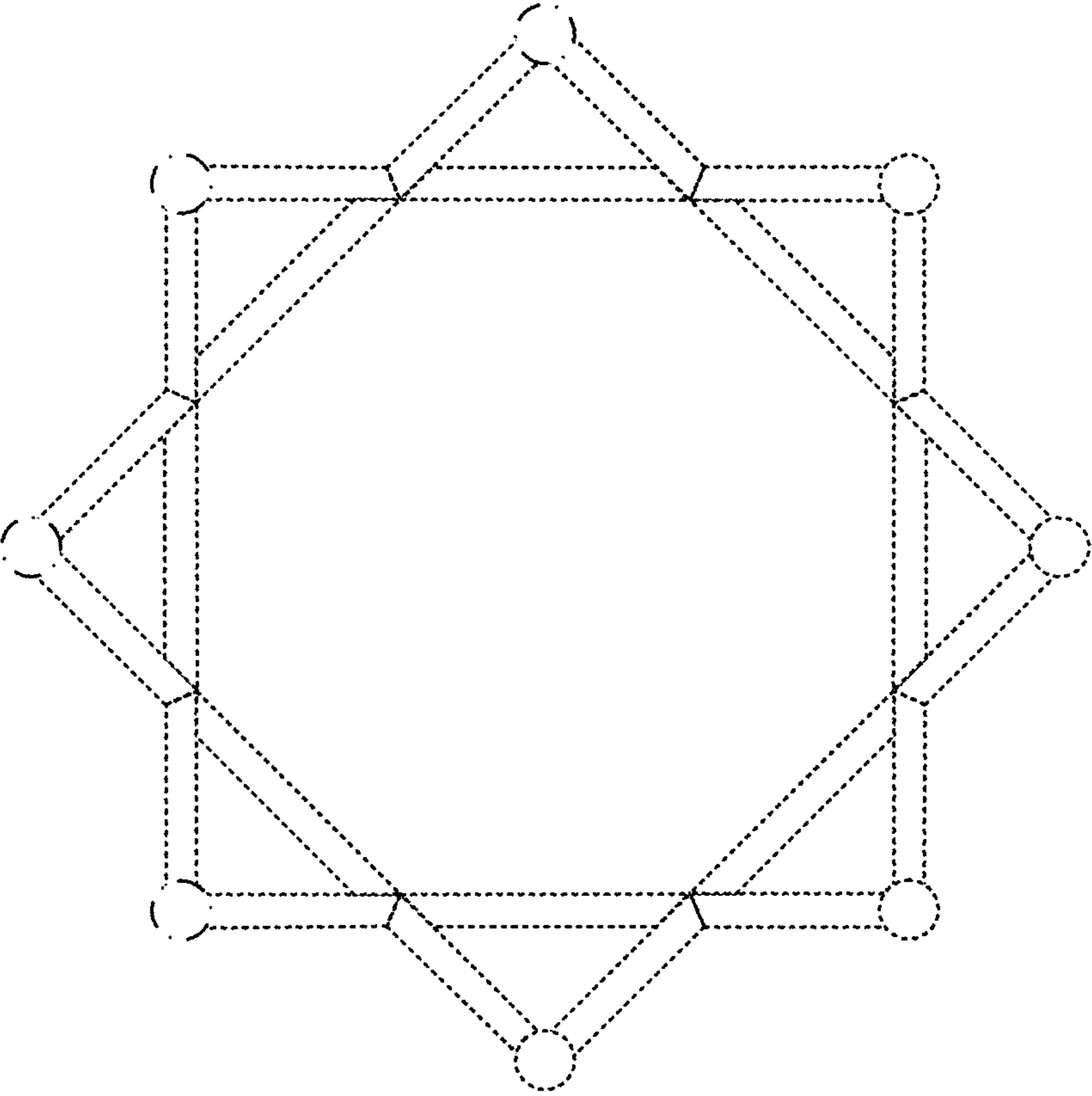

FIG. 2

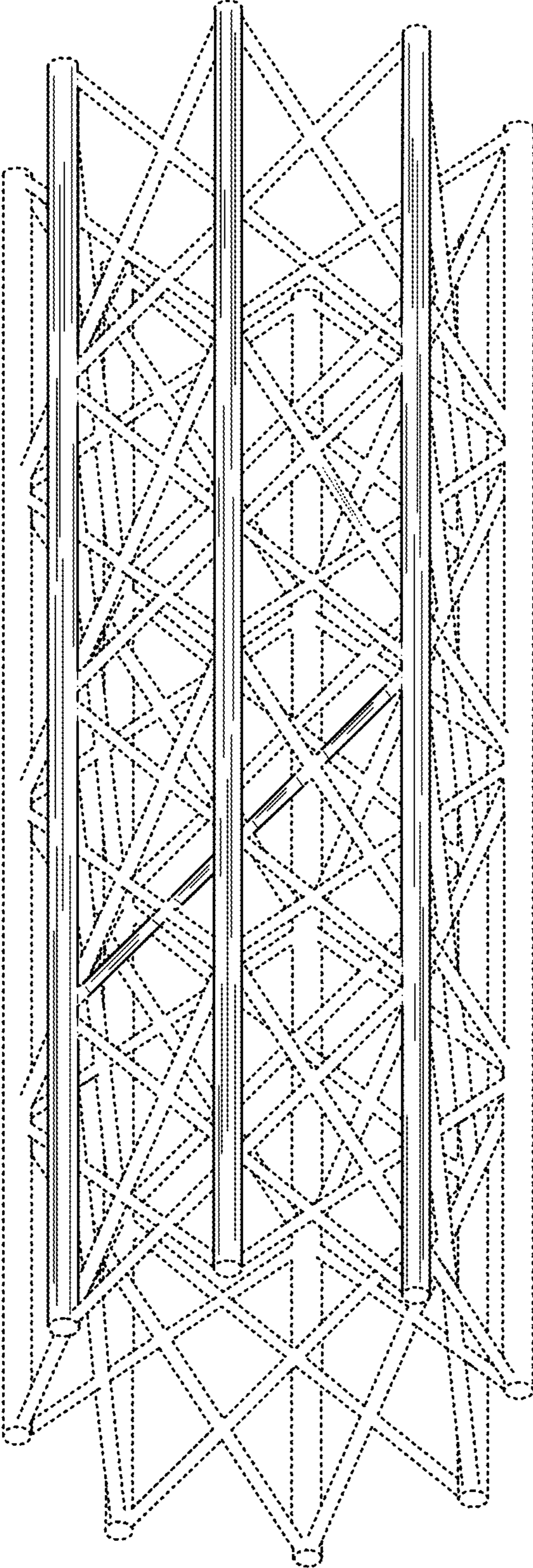

FIG. 3

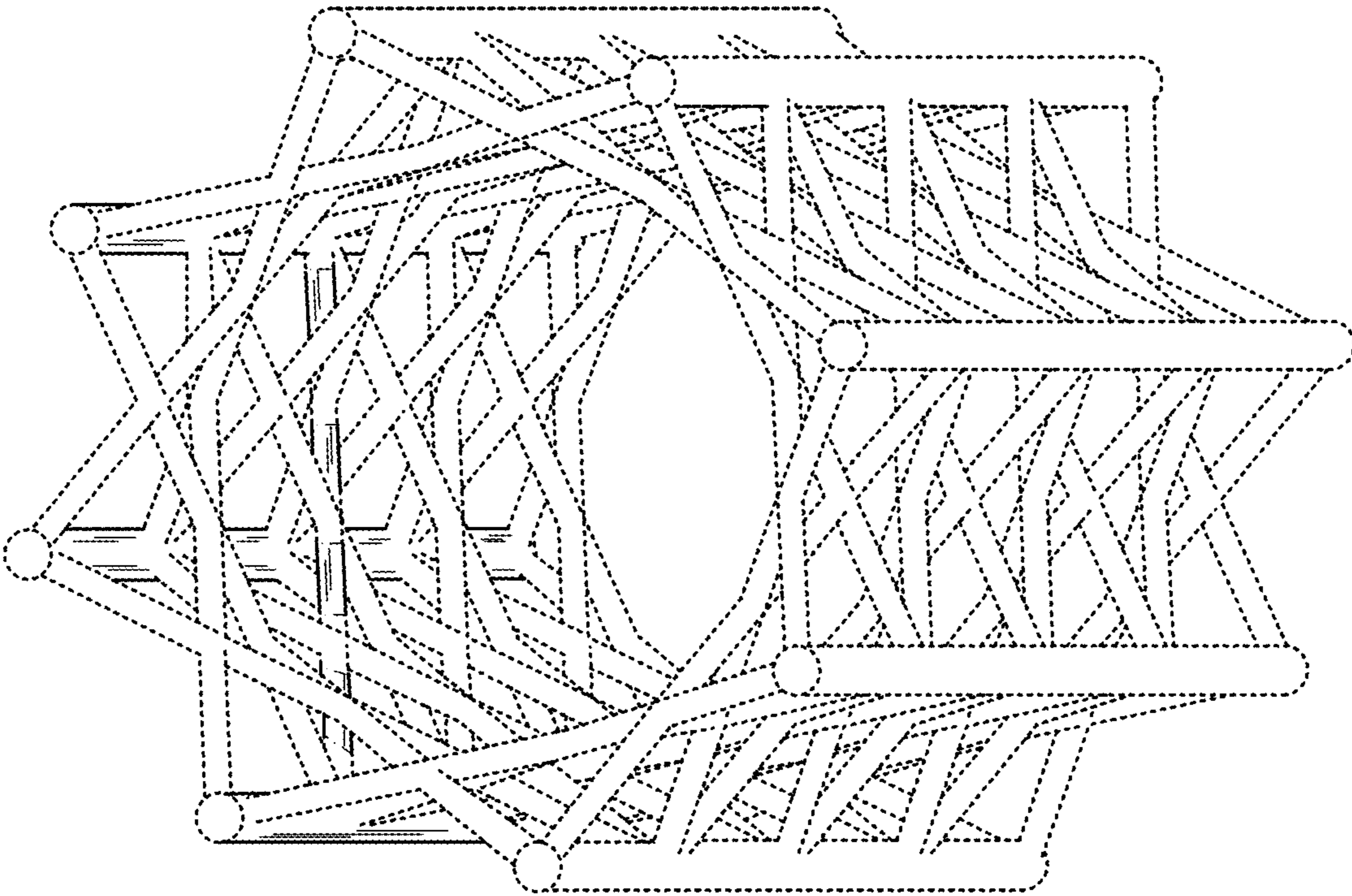

FIG. 4

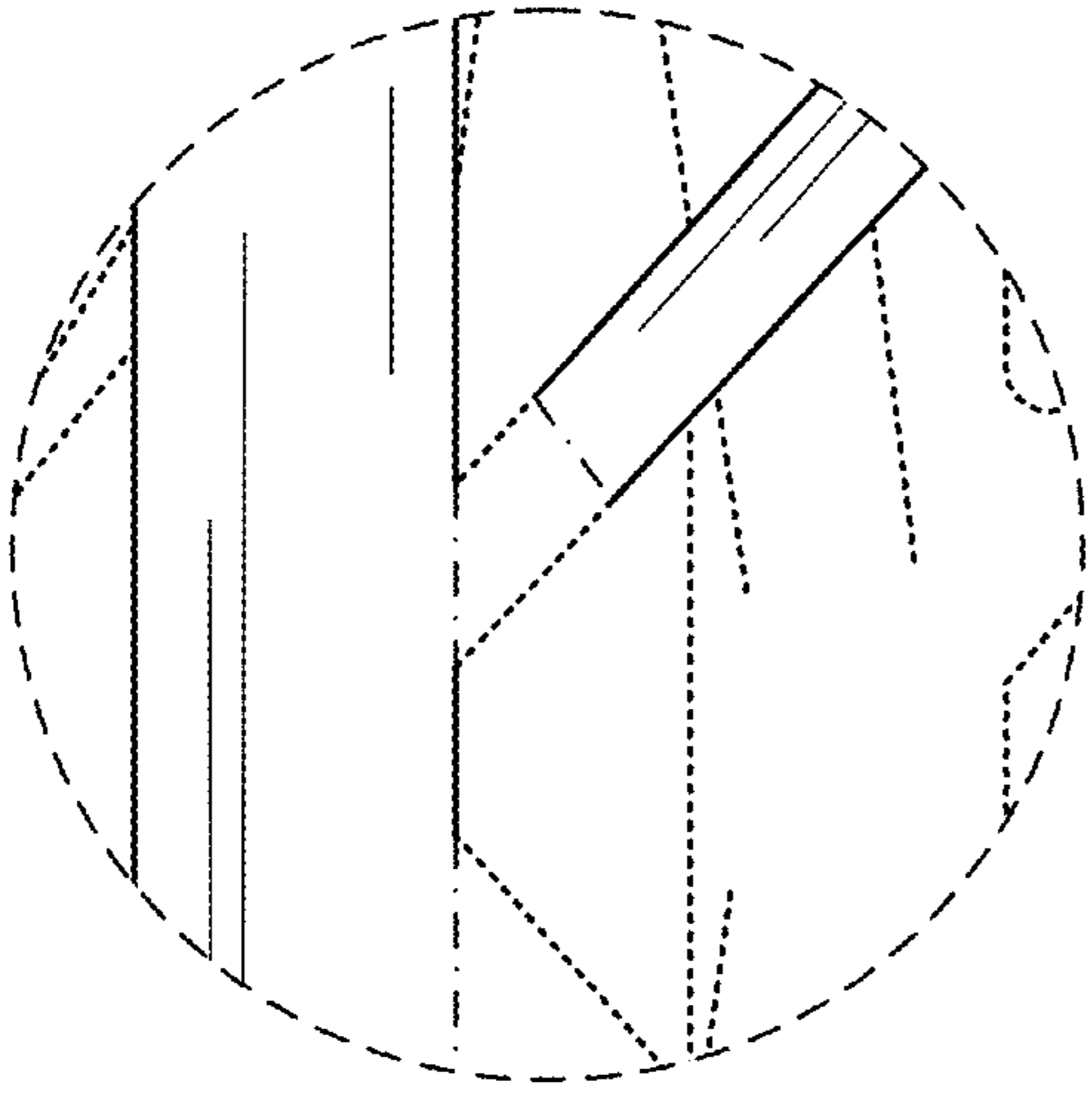

FIG. 5

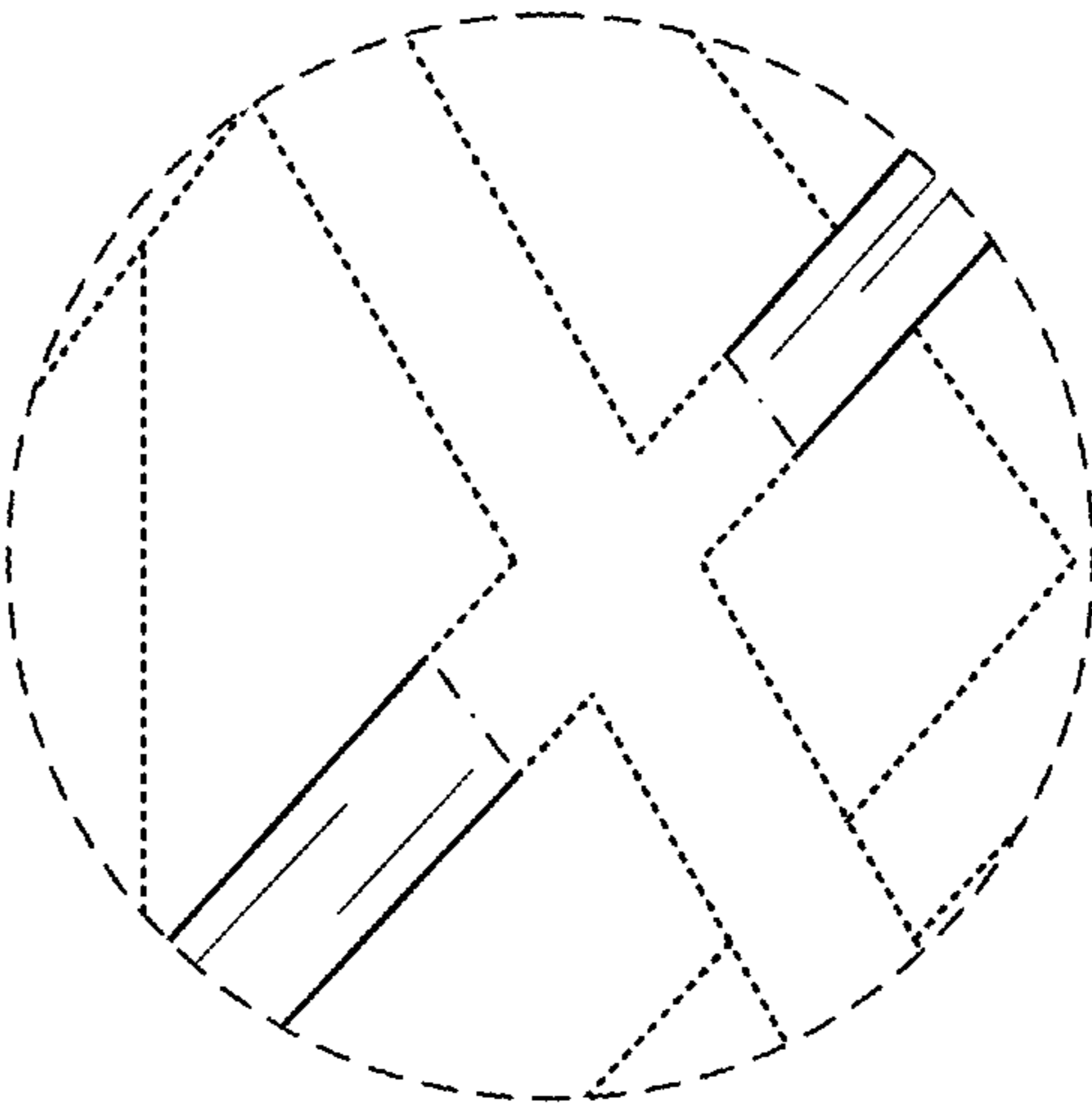

FIG. 6