



US00D895127S

(12) **United States Design Patent**
Carroll et al.

(10) **Patent No.:** **US D895,127 S**
(45) **Date of Patent:** **** Sep. 1, 2020**

(54) **WOUND THERAPY TRAINING DEVICE**

(71) Applicant: **KCI Licensing, Inc.**, San Antonio, TX (US)

(72) Inventors: **Christopher A. Carroll**, San Antonio, TX (US); **Justin Rice**, San Antonio, TX (US); **Shannon C. Ingram**, Bulverde, TX (US); **Victor Clarke**, San Antonio, TX (US)

(73) Assignee: **KCI LICENSING, INC.**, San Antonio, TX (US)

(**) Term: **15 Years**

(21) Appl. No.: **29/670,355**

(22) Filed: **Nov. 15, 2018**

(51) **LOC (12) Cl.** **24-01**

(52) **U.S. Cl.**
USPC **D24/189**

(58) **Field of Classification Search**
USPC D24/127-130, 187-190; D20/42
(Continued)

(56) **References Cited**

U.S. PATENT DOCUMENTS

1,355,846 A 10/1920 Rannells
2,547,758 A 4/1951 Keeling
(Continued)

FOREIGN PATENT DOCUMENTS

AU 550575 B2 3/1986
AU 745271 B2 3/2002
(Continued)

OTHER PUBLICATIONS

Louis C. Argenta, MD and Michael J. Morykwas, PHD; Vacuum-Assisted Closure: A New Method for Wound Control and Treat-

ment: Clinical Experience; Annals of Plastic Surgery; vol. 38, No. 6, Jun. 1997; pp. 563-576.

(Continued)

Primary Examiner — Jennifer L Watkins

(74) *Attorney, Agent, or Firm* — Foley & Lardner LLP

(57) **CLAIM**

We claim the ornamental design for a wound therapy training device, as shown and described.

DESCRIPTION

FIG. 1 is a top perspective view of an embodiment of the claimed design;

FIG. 2 is a bottom perspective view thereof;

FIG. 3 is a top view thereof;

FIG. 4 is a bottom side view thereof;

FIG. 5 is a right side view thereof;

FIG. 6 is a left view thereof; and

FIG. 7 is a front view thereof;

FIG. 8 is a rear view thereof;

FIG. 9 is a cross-sectional view thereof along line 9-9 shown on FIG. 1;

FIG. 10 is a front perspective view thereof in one possible usage environment;

FIG. 11 is a top perspective view of another embodiment of the claimed design;

FIG. 12 is a bottom perspective view thereof;

FIG. 13 is a top view thereof;

FIG. 14 is a bottom side view thereof;

FIG. 15 is a right side view thereof;

FIG. 16 is a left view thereof; and

FIG. 17 is a front view thereof;

FIG. 18 is a rear view thereof;

FIG. 19 is a cross-sectional view thereof along line 19-19 shown on FIG. 11; and,

FIG. 20 is a front perspective view thereof in one possible usage environment.

The broken lines in the FIG. 10 and FIG. 20 depict environment and form no part of the claim.

1 Claim, 12 Drawing Sheets

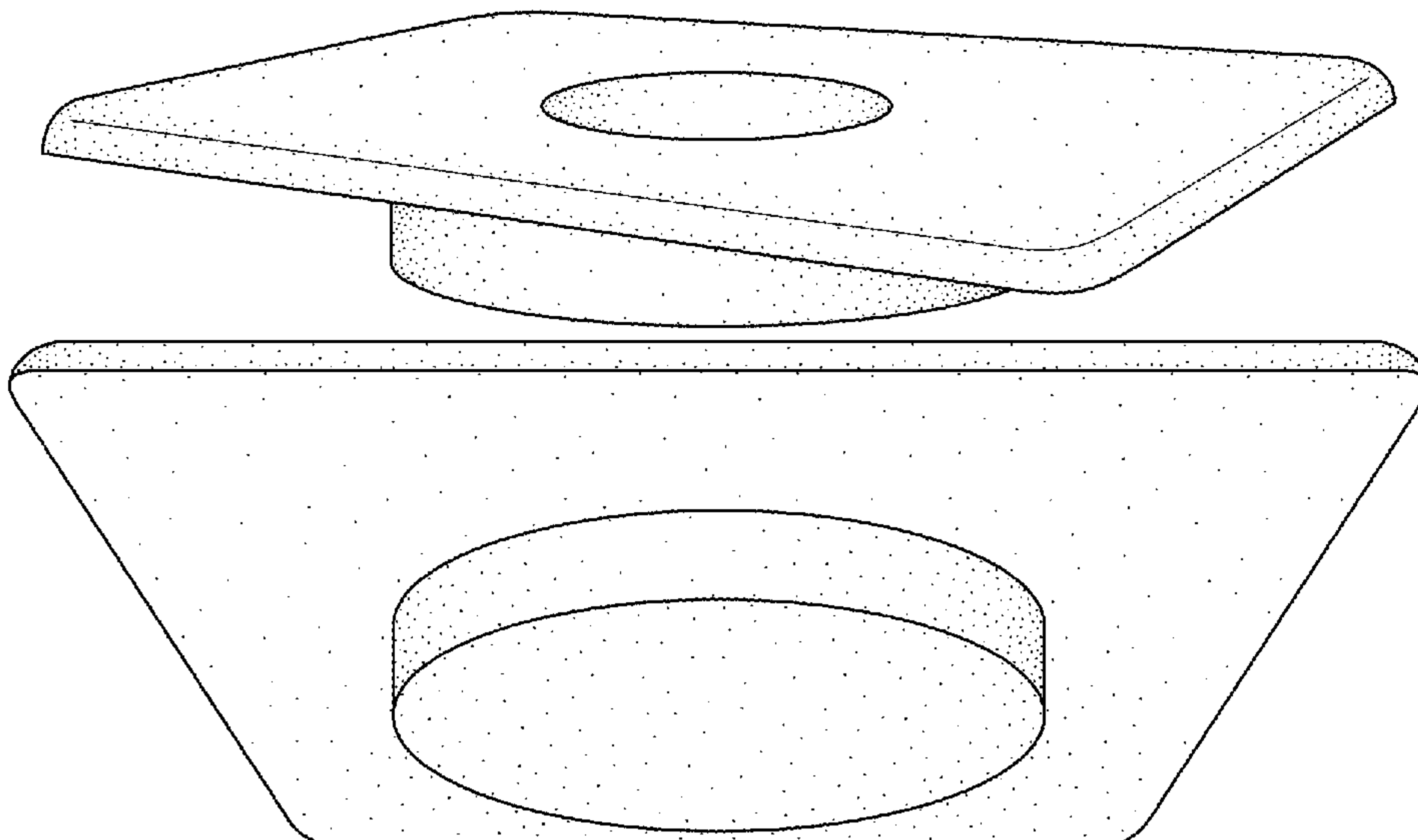

(58) **Field of Classification Search**

CPC A61F 13/023; A61F 13/0259; A61F 2013/00412; A61F 2013/00846; A61F 13/0203; A61B 5/0408; A61N 1/0456; Y10T 428/14; Y10T 428/15; Y10T 428/149; Y10T 428/1495; Y10T 428/1471; Y10T 428/24793; Y10T 428/24802; Y10T 428/1476; Y10T 428/24777; Y10T 428/2848

See application file for complete search history.

4,985,019	A	1/1991	Michelson
5,037,397	A	8/1991	Kalt et al.
5,086,170	A	2/1992	Luheshi et al.
5,092,858	A	3/1992	Benson et al.
5,100,396	A	3/1992	Zamierowski
5,134,994	A	8/1992	Say
5,149,331	A	9/1992	Ferdman et al.
5,167,613	A	12/1992	Karami et al.
5,176,663	A	1/1993	Svedman et al.
5,215,522	A	6/1993	Page et al.
5,232,453	A	8/1993	Plass et al.
5,261,893	A	11/1993	Zamierowski
5,278,100	A	1/1994	Doan et al.
5,279,550	A	1/1994	Habib et al.
5,298,015	A	3/1994	Komatsuzaki et al.
5,342,376	A	8/1994	Ruff
5,344,415	A	9/1994	DeBusk et al.
5,358,494	A	10/1994	Svedman
5,437,622	A	8/1995	Carion
5,437,651	A	8/1995	Todd et al.
5,527,293	A	6/1996	Zamierowski
5,549,584	A	8/1996	Gross
5,556,375	A	9/1996	Ewall
5,607,388	A	3/1997	Ewall
5,636,643	A	6/1997	Argenta et al.
5,645,081	A	7/1997	Argenta et al.
6,071,267	A	6/2000	Zamierowski
6,135,116	A *	10/2000	Vogel A61F 13/069 128/898
6,241,747	B1	6/2001	Ruff
6,287,316	B1	9/2001	Agarwal et al.
6,345,623	B1	2/2002	Heaton et al.
6,488,643	B1 *	12/2002	Tumey A61F 5/0111 601/150
6,493,568	B1 *	12/2002	Bell G16H 10/60 600/323
6,553,998	B2	4/2003	Heaton et al.
6,814,079	B2	11/2004	Heaton et al.
D693,009	S *	11/2013	Green D24/188
D735,346	S *	7/2015	Cotton D24/189
D798,460	S *	9/2017	Farley D24/189
D808,022	S *	1/2018	Ingemarsson-Matzen D24/188
D808,534	S *	1/2018	Brezoczky D24/189
D810,308	S *	2/2018	Lind D24/189
D841,821	S *	2/2019	Sorbel D24/188
D875,954	S *	2/2020	Tarkington D24/189
D878,606	S *	3/2020	Minnelli A61B 17/0218 D24/189
D879,308	S *	3/2020	Park D24/189
2002/0077661	A1	6/2002	Saadat
2002/0115951	A1	8/2002	Norstrem et al.
2002/0120185	A1	8/2002	Johnson
2002/0143286	A1	10/2002	Tumey

(56)

References Cited

U.S. PATENT DOCUMENTS

2,632,443	A	3/1953	Leshner
2,682,873	A	7/1954	Evans et al.
2,910,763	A	11/1959	Lauterbach
2,969,057	A	1/1961	Simmons
3,066,672	A	12/1962	Crosby, Jr. et al.
3,367,332	A	2/1968	Groves
3,520,300	A	7/1970	Flower, Jr.
3,568,675	A	3/1971	Harvey
3,648,692	A	3/1972	Wheeler
3,682,180	A	8/1972	McFarlane
3,826,254	A	7/1974	Mellor
4,080,970	A	3/1978	Miller
4,096,853	A	6/1978	Weigand
4,139,004	A	2/1979	Gonzalez, Jr.
4,165,748	A	8/1979	Johnson
4,184,510	A	1/1980	Murry et al.
4,233,969	A	11/1980	Lock et al.
4,245,630	A	1/1981	Lloyd et al.
4,256,109	A	3/1981	Nichols
4,261,363	A	4/1981	Russo
4,275,721	A	6/1981	Olson
4,284,079	A	8/1981	Adair
4,297,995	A	11/1981	Golub
4,333,468	A	6/1982	Geist
4,373,519	A	2/1983	Errede et al.
4,382,441	A	5/1983	Svedman
4,392,853	A	7/1983	Muto
4,392,858	A	7/1983	George et al.
4,419,097	A	12/1983	Rowland
4,465,485	A	8/1984	Kashmer et al.
4,475,909	A	10/1984	Eisenberg
4,480,638	A	11/1984	Schmid
4,525,166	A	6/1985	Leclerc
4,525,374	A	6/1985	Vaillancourt
4,540,412	A	9/1985	Van Overloop
4,543,100	A	9/1985	Brodsky
4,548,202	A	10/1985	Duncan
4,551,139	A	11/1985	Plaas et al.
4,569,348	A	2/1986	Hasslinger
4,605,399	A	8/1986	Weston et al.
4,608,041	A	8/1986	Nielsen
4,640,688	A	2/1987	Hauser
4,655,754	A	4/1987	Richmond et al.
4,664,662	A	5/1987	Webster
4,710,165	A	12/1987	McNeil et al.
4,733,659	A	3/1988	Edenbaum et al.
4,743,232	A	5/1988	Kruger
4,758,220	A	7/1988	Sundblom et al.
4,787,888	A	11/1988	Fox
4,826,494	A	5/1989	Richmond et al.
4,838,883	A	6/1989	Matsuura
4,840,187	A	6/1989	Brazier
4,863,449	A	9/1989	Therriault et al.
4,872,450	A	10/1989	Austad
4,878,901	A	11/1989	Sachse
4,897,081	A	1/1990	Poirier et al.
4,906,233	A	3/1990	Moriuchi et al.
4,906,240	A	3/1990	Reed et al.
4,919,654	A	4/1990	Kalt
4,941,882	A	7/1990	Ward et al.
4,953,565	A	9/1990	Tachibana et al.
4,969,880	A	11/1990	Zamierowski

FOREIGN PATENT DOCUMENTS

AU	755496	B2	12/2002
CA	2005436	A1	6/1990
DE	26 40 413	A1	3/1978
DE	43 06 478	A1	9/1994
DE	29 504 378	U1	9/1995
EP	0100148	A1	2/1984
EP	0117632	A2	9/1984
EP	0161865	A2	11/1985
EP	0358302	A2	3/1990
EP	1018967	A1	7/2000
GB	692578	A	6/1953
GB	2 195 255	A	4/1988
GB	2 197 789	A	6/1988
GB	2 220 357	A	1/1990
GB	2 235 877	A	3/1991
GB	2 329 127	A	3/1999
GB	2 333 965	A	8/1999
JP	4129536	B2	8/2008
SG	71559		4/2002
WO	80/02182	A1	10/1980
WO	87/04626	A1	8/1987

(56)

References Cited

FOREIGN PATENT DOCUMENTS

WO	90/010424	A1	9/1990
WO	93/009727	A1	5/1993
WO	94/020041	A1	9/1994
WO	96/05873	A1	2/1996
WO	97/18007	A1	5/1997
WO	99/13793	A1	3/1999

OTHER PUBLICATIONS

Susan Mendez-Eatmen, RN; "When wounds Won't Heal" RN Jan. 1998, vol. 61 (1); Medical Economics Company, Inc., Montvale, NJ, USA; pp. 20-24.

James H. Blackburn II, MD et al.: Negative-Pressure Dressings as a Bolster for Skin Grafts; *Annals of Plastic Surgery*, vol. 40, No. 5, May 1998, pp. 453-457; Lippincott Williams & Wilkins, Inc., Philadelphia, PA, USA.

John Masters; "Reliable, Inexpensive and Simple Suction Dressings"; Letter to the Editor, *British Journal of Plastic Surgery*, 1998, vol. 51 (3), p. 267; Elsevier Science/The British Association of Plastic Surgeons, UK.

S.E. Greer, et al. "The Use of Subatmospheric Pressure Dressing Therapy to Close Lymphocutaneous Fistulas of the Groin" *British Journal of Plastic Surgery* (2000), 53, pp. 484-487.

George V. Letsou, MD., et al; "Stimulation of Adenylate Cyclase Activity in Cultured Endothelial Cells Subjected to Cyclic Stretch"; *Journal of Cardiovascular Surgery*, 31, 1990, pp. 634-639.

Orringer, Jay, et al; "Management of Wounds in Patients with Complex Enterocutaneous Fistulas"; *Surgery, Gynecology & Obstetrics*, Jul. 1987, vol. 165, pp. 79-80.

International Search Report for PCT International Application PCT/GB95/01983; dated Nov. 23, 1995.

PCT International Search Report for PCT International Application PCT/GB98/02713; dated Jan. 8, 1999.

PCT Written Opinion; PCT International Application PCT/GB98/02713; dated Jun. 8, 1999.

PCT International Examination and Search Report, PCT International Application PCT/GB96/02802; dated Jan. 15, 1998 & Apr. 29, 1997.

PCT Written Opinion, PCT International Application PCT/GB96/02802; dated Sep. 3, 1997.

Dattilo, Philip P., Jr., et al; "Medical Textiles: Application of an Absorbable Barbed Bi-directional Surgical Suture"; *Journal of Textile and Apparel, Technology and Management*, vol. 2, Issue 2, Spring 2002, pp. 1-5.

Kostyuchenok, B.M., et al; "Vacuum Treatment in the Surgical Management of Purulent Wounds"; *Vestnik Khirurgi*, Sep. 1986, pp. 18-21 and 6 page English translation thereof.

Davydov, Yu. A., et al; "Vacuum Therapy in the Treatment of Purulent Lactation Mastitis"; *Vestnik Khirurgi*, May 14, 1986, pp. 66-70, and 9 page English translation thereof.

Yusupov, Yu.N., et al; "Active Wound Drainage"; *Vestnki Khirurgi*, vol. 138, Issue 4, 1987, and 7 page English translation thereof.

Davydov, Yu.A., et al; "Bacteriological and Cytological Assessment of Vacuum Therapy for Purulent Wounds"; *Vestnik Khirurgi*, Oct. 1988, pp. 48-52, and 8 page English translation thereof.

Davydov, Yu.A., et al; "Concepts for the Clinical-Biological Management of the Wound Process in the Treatment of Purulent Wounds by Means of Vacuum Therapy"; *Vestnik Khirurgi*, Jul. 7, 1980, pp. 132-136, and 8 page English translation thereof.

Chariker, Mark E., M.D., et al; "Effective Management of incisional and cutaneous fistulae with closed suction wound drainage"; *Contemporary Surgery*, vol. 34, Jun. 1989, pp. 59-63.

Egnell Minor, Instruction Book, First Edition, 300 7502, Feb. 1975, pp. 24.

Egnell Minor: Addition to the Users Manual Concerning Overflow Protection—Concerns all Egnell Pumps, Feb. 3, 1983, pp. 2.

Svedman, P.: "Irrigation Treatment of Leg Ulcers", *The Lancet*, Sep. 3, 1983, pp. 532-534.

Chinn, Steven D. et al.: "Closed Wound Suction Drainage", *The Journal of Foot Surgery*, vol. 24, No. 1, 1985, pp. 76-81.

Arnljots, Björn et al.: "Irrigation Treatment in Split-Thickness Skin Grafting of Intractable Leg Ulcers", *Scand J. Plast Reconstr. Surg.*, No. 19, 1985, pp. 211-213.

Svedman, P.: "A Dressing Allowing Continuous Treatment of a Biosurface", *IRCS Medical Science: Biomedical Technology, Clinical Medicine, Surgery and Transplantation*, vol. 7, 1979, p. 221.

Svedman, P. et al: "A Dressing System Providing Fluid Supply and Suction Drainage Used for Continuous or Intermittent Irrigation", *Annals of Plastic Surgery*, vol. 17, No. 2, Aug. 1986, pp. 125-133.

N.A. Bagautdinov, "Variant of External Vacuum Aspiration in the Treatment of Purulent Diseases of Soft Tissues," *Current Problems in Modern Clinical Surgery: Interdepartmental Collection*, edited by V. Ye Volkov et al. (Chuvashia State University, Cheboksary, U.S.S.R. 1986); pp. 94-96 (copy and certified translation).

K.F. Jeter, T.E. Tintle, and M. Chariker, "Managing Draining Wounds and Fistulae: New and Established Methods," *Chronic Wound Care*, edited by D. Krasner (Health Management Publications, Inc., King of Prussia, PA 1990), pp. 240-246.

G. Živadnovi?, V. ?uki?, Ž. Maksimovi?, ?. Radak, and P. Peška, "Vacuum Therapy in the Treatment of Peripheral Blood Vessels," *Timok Medical Journal* 11 (1986), pp. 161-164 (copy and certified translation).

F.E. Johnson, "An Improved Technique for Skin Graft Placement Using a Suction Drain," *Surgery, Gynecology, and Obstetrics* 159 (1984), pp. 584-585.

A.A. Safronov, Dissertation Abstract, Vacuum Therapy of Trophic Ulcers of the Lower Leg with Simultaneous Autoplasty of the Skin (Central Scientific Research Institute of Traumatology and Orthopedics, Moscow, U.S.S.R. 1967) (copy and certified translation).

M. Schein, R. Saadia, J.R. Jamieson, and G.A.G. Decker, "The 'Sandwich Technique' in the Management of the Open Abdomen," *British Journal of Surgery* 73 (1986), pp. 369-370.

D.E. Tribble, An Improved Sump Drain-Irrigation Device of Simple Construction, *Archives of Surgery* 105 (1972) pp. 511-513.

M.J. Morykwas, L.C. Argenta, E.I. Shelton-Brown, and W. McGuirt, "Vacuum-Assisted Closure: A New Method for Wound Control and Treatment: Animal Studies and Basic Foundation," *Annals of Plastic Surgery* 38 (1997), pp. 553-562 (Morykwas I).

C.E. Tennants, "The Use of Hyperemia in the Postoperative Treatment of Lesions of the Extremities and Thorax," *Journal of the American Medical Association* 64 (1915), pp. 1548-1549.

Selections from W. Meyer and V. Schmieden, Bier's Hyperemic Treatment in Surgery, Medicine, and the Specialties: A Manual of Its Practical Application, (W.B. Saunders Co., Philadelphia, PA 1909), pp. 17-25, 44-64, 90-96, 167-170, and 210-211.

V.A. Solovev et al., Guidelines, The Method of Treatment of Immature External Fistulas in the Upper Gastrointestinal Tract, editor-in-chief Prov. V.I. Parahonyak (S.M. Kirov Gorky State Medical Institute, Gorky, U.S.S.R. 1987) ("Solovev Guidelines").

V.A. Kuznetsov & N.a. Bagautdinov, "Vacuum and Vacuum-Sorption Treatment of Open Septic Wounds," in II All-Union Conference on Wounds and Wound Infections: Presentation Abstracts, edited by B.M. Kostyuchenok et al. (Moscow, U.S.S.R. Oct. 28-29, 1986) pp. 91-92 ("Bagautdinov II").

V.A. Solovev, Dissertation Abstract, Treatment and Prevention of Suture Failures after Gastric Resection (S.M. Kirov Gorky State Medical Institute, Gorky, U.S.S.R. 1988) ("Solovev Abstract").

V.A.C.® Therapy Clinical Guidelines: A Reference Source for Clinicians; Jul. 2007.

* cited by examiner

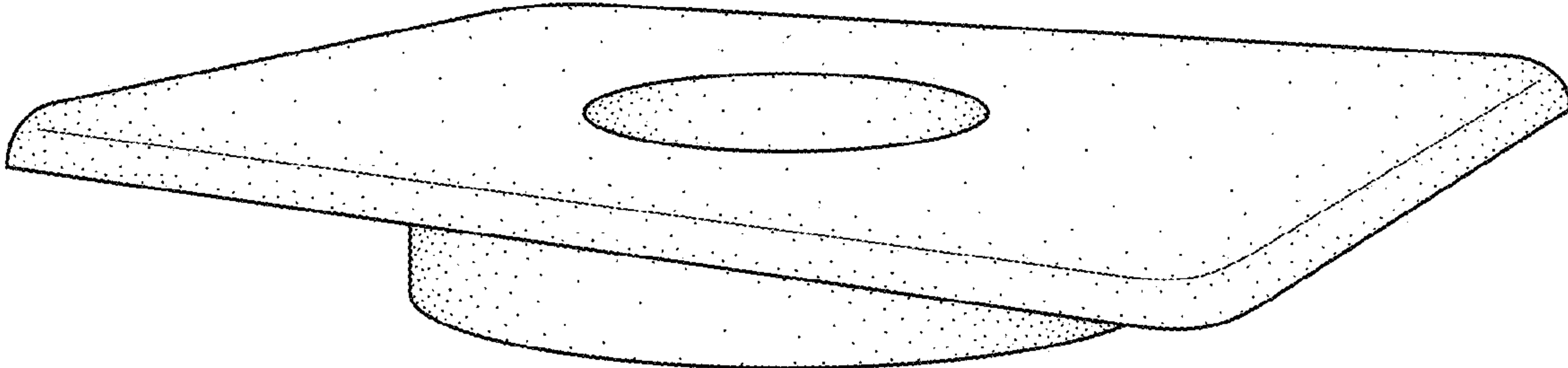

FIG. 1

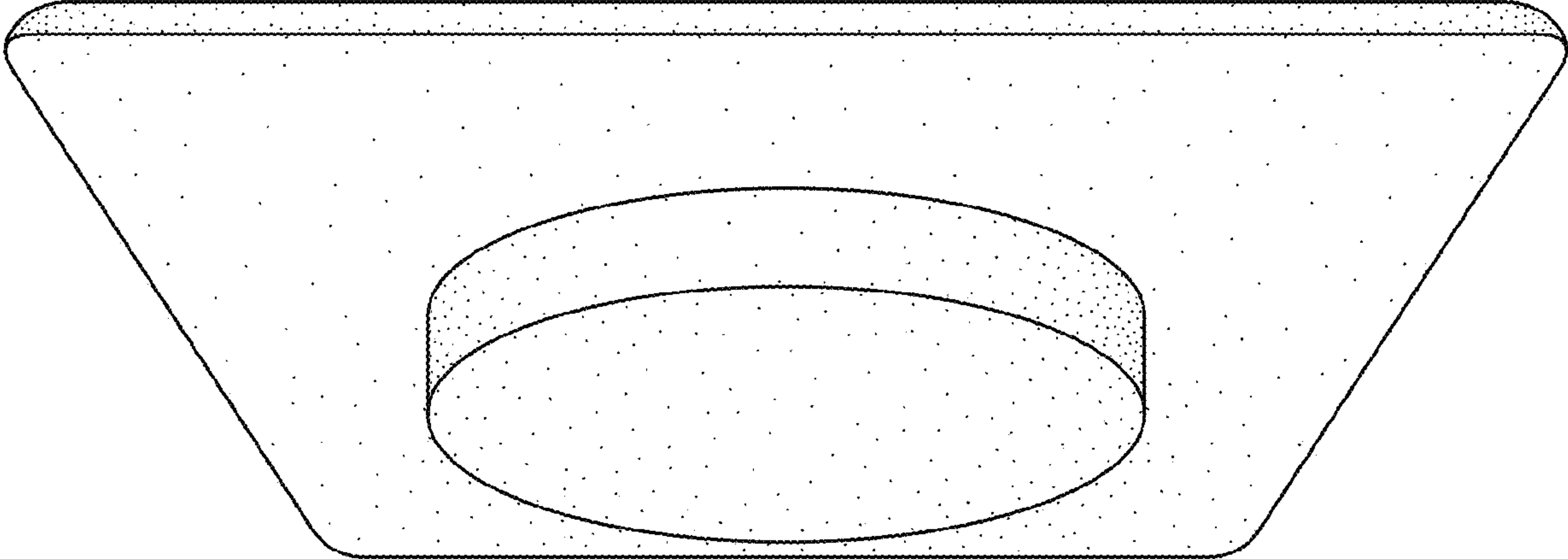

FIG. 2

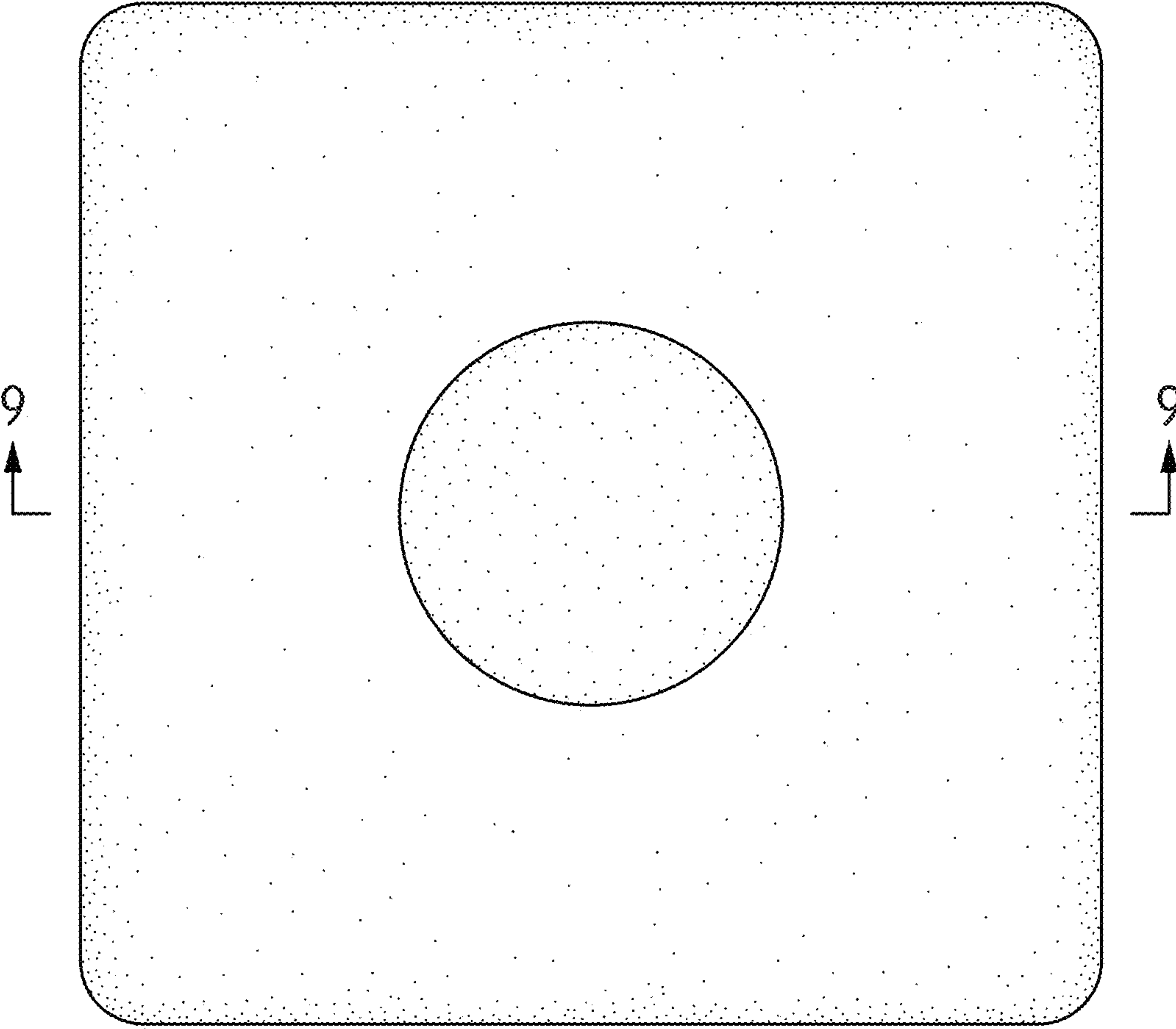

FIG. 3

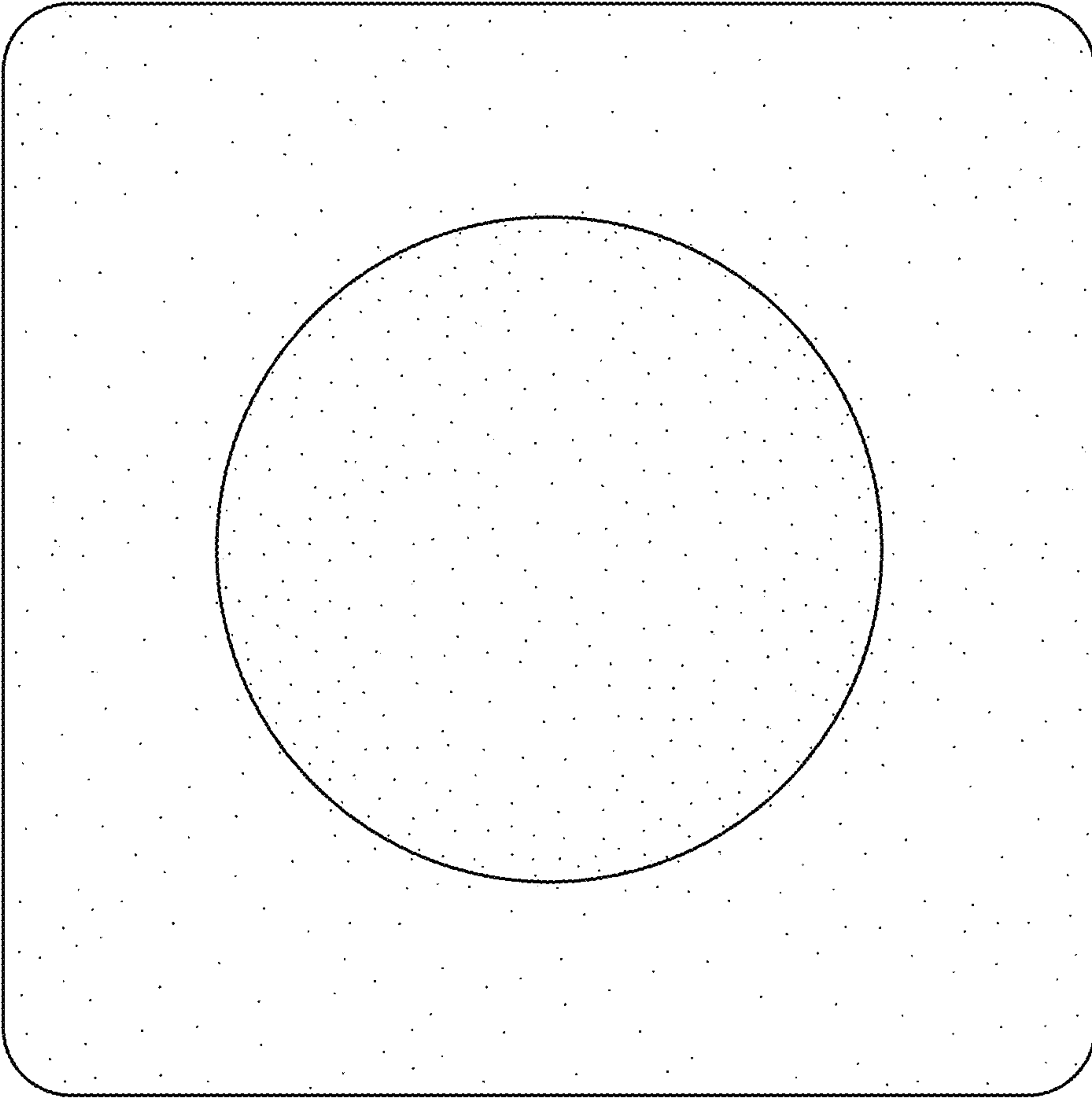

FIG. 4

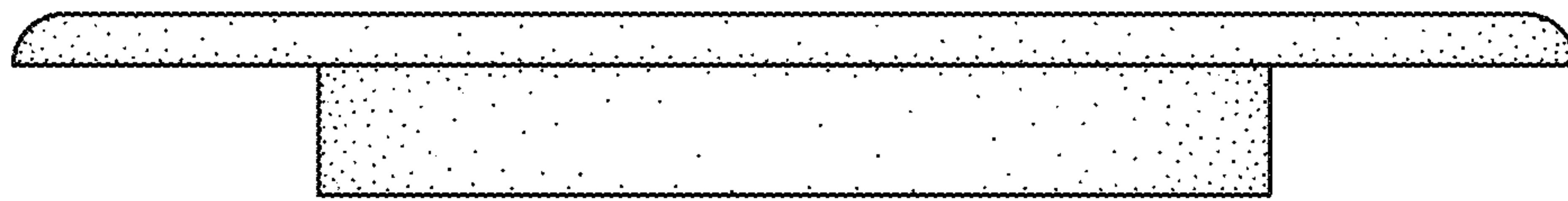

FIG. 5

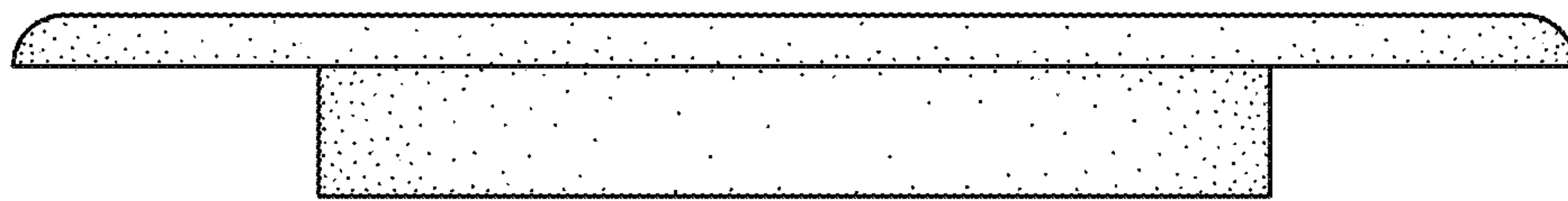

FIG. 6

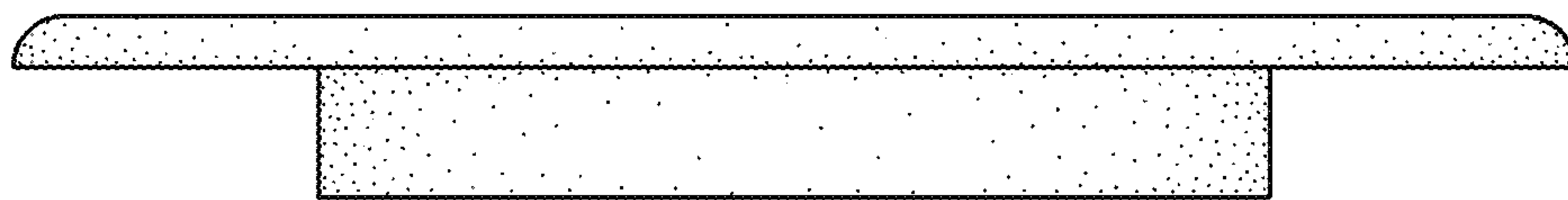

FIG. 7

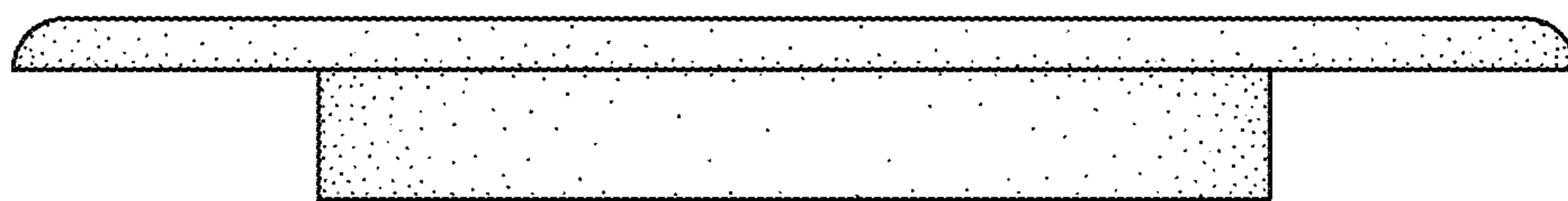

FIG. 8

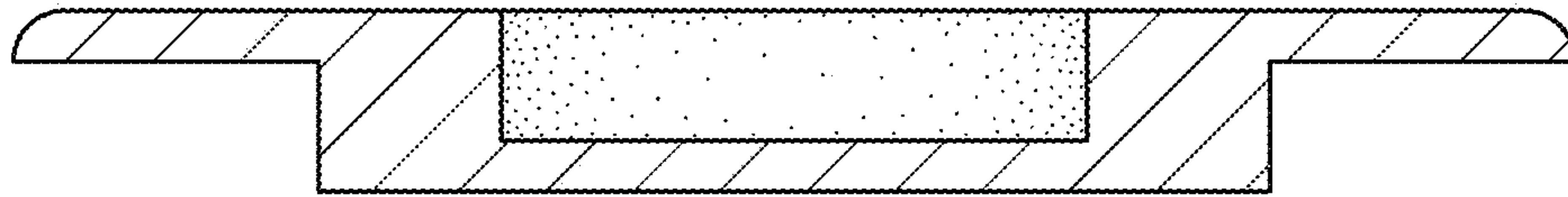

FIG. 9

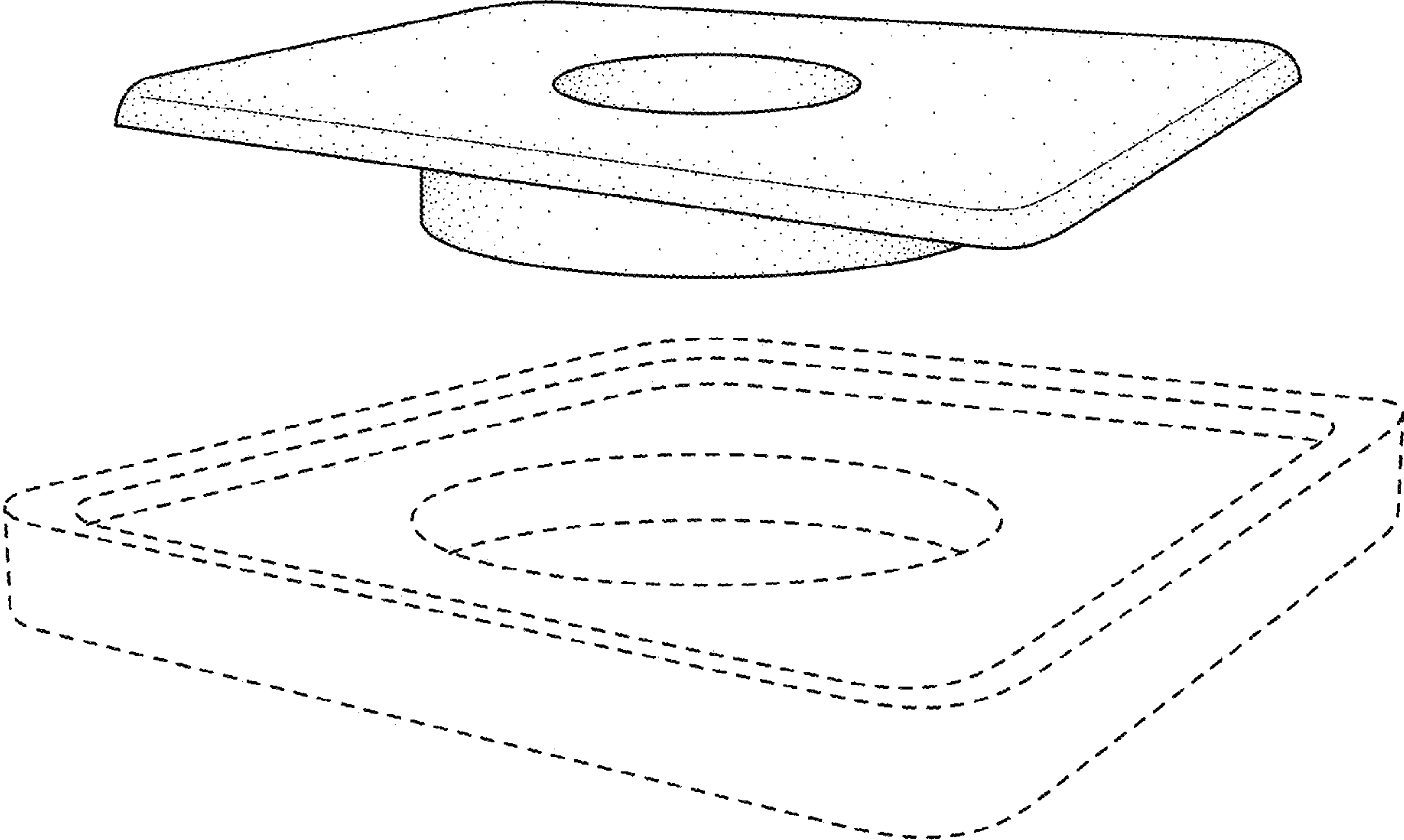

FIG. 10

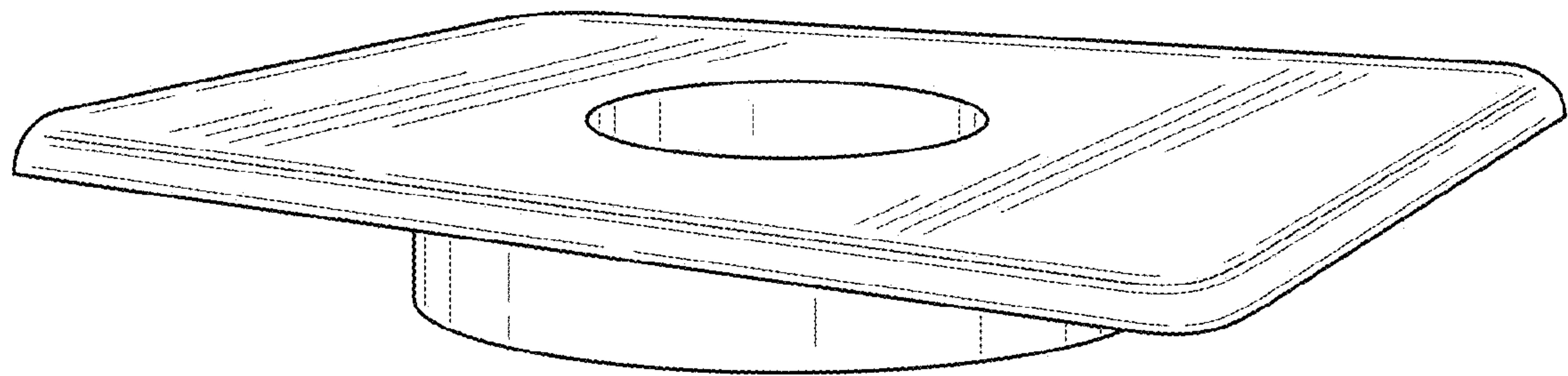

FIG. 11

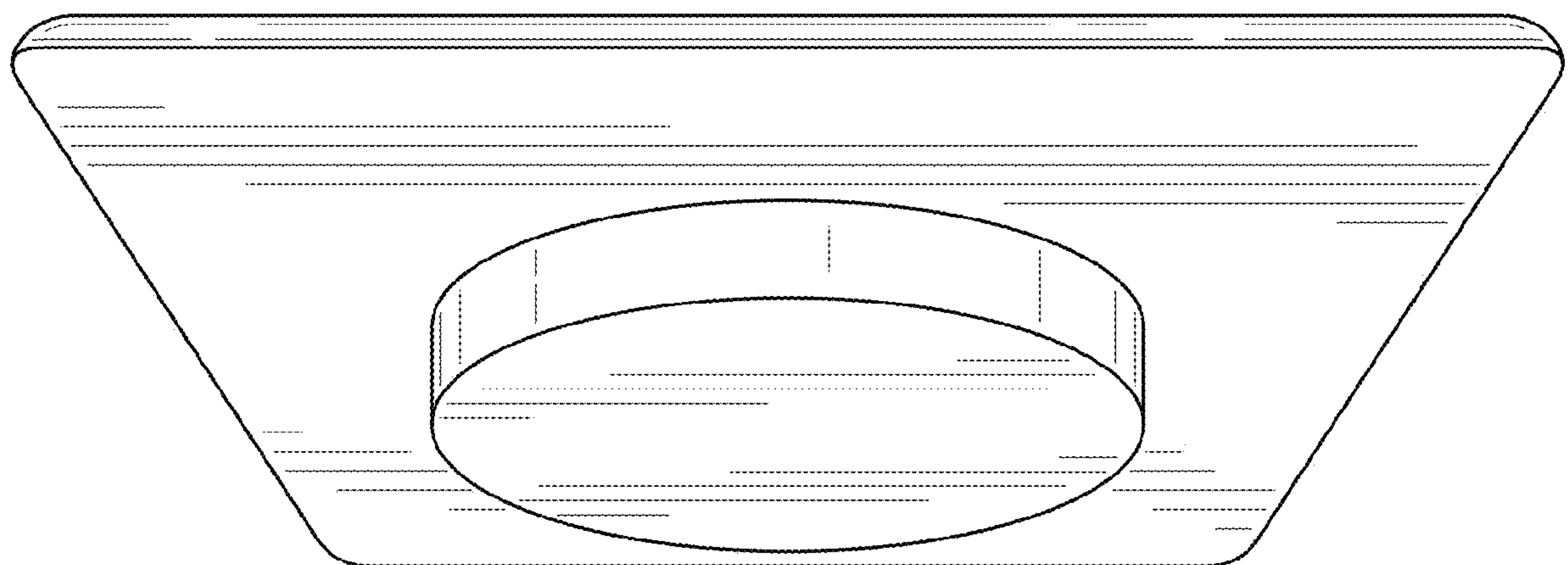

FIG. 12

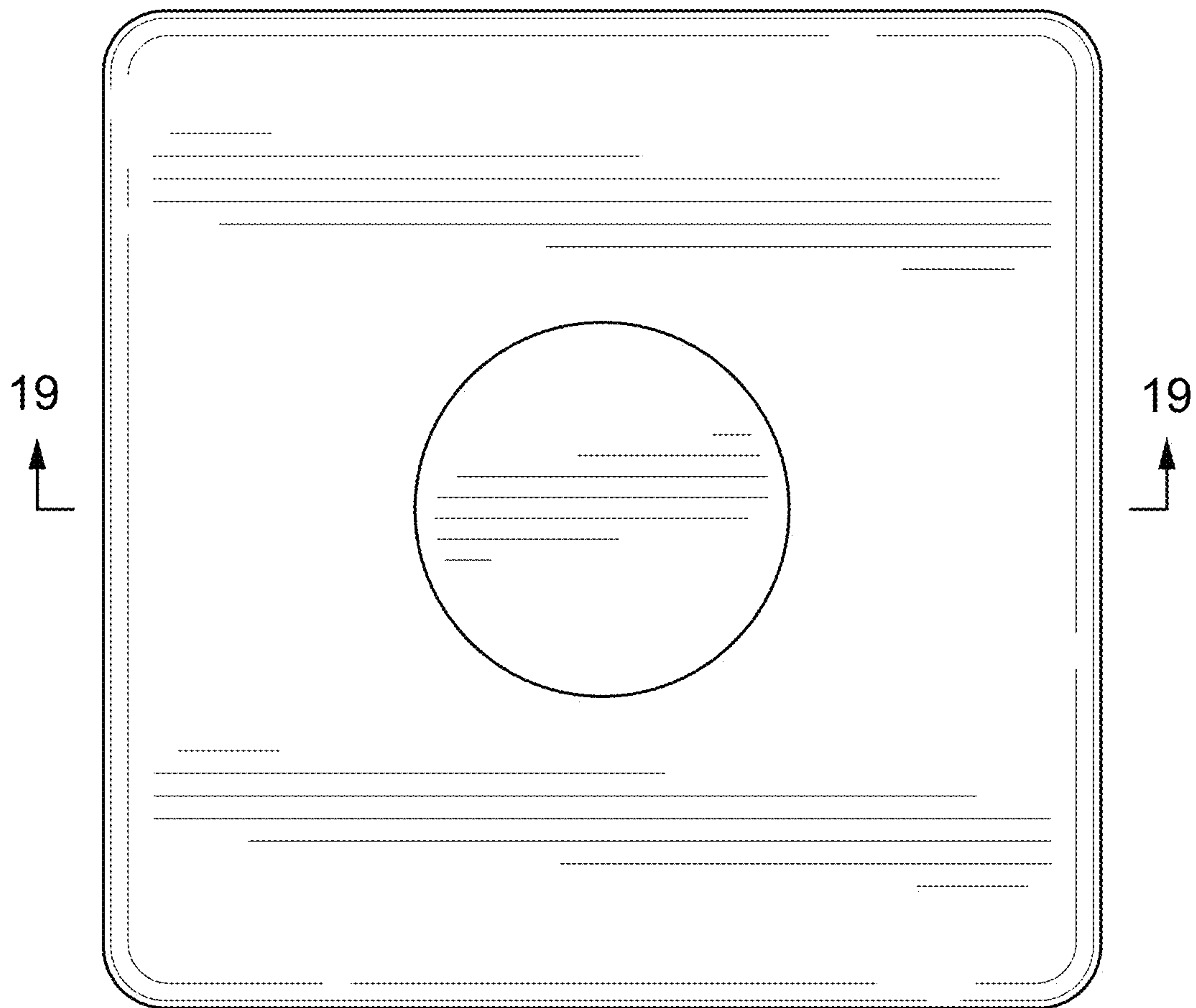

FIG. 13

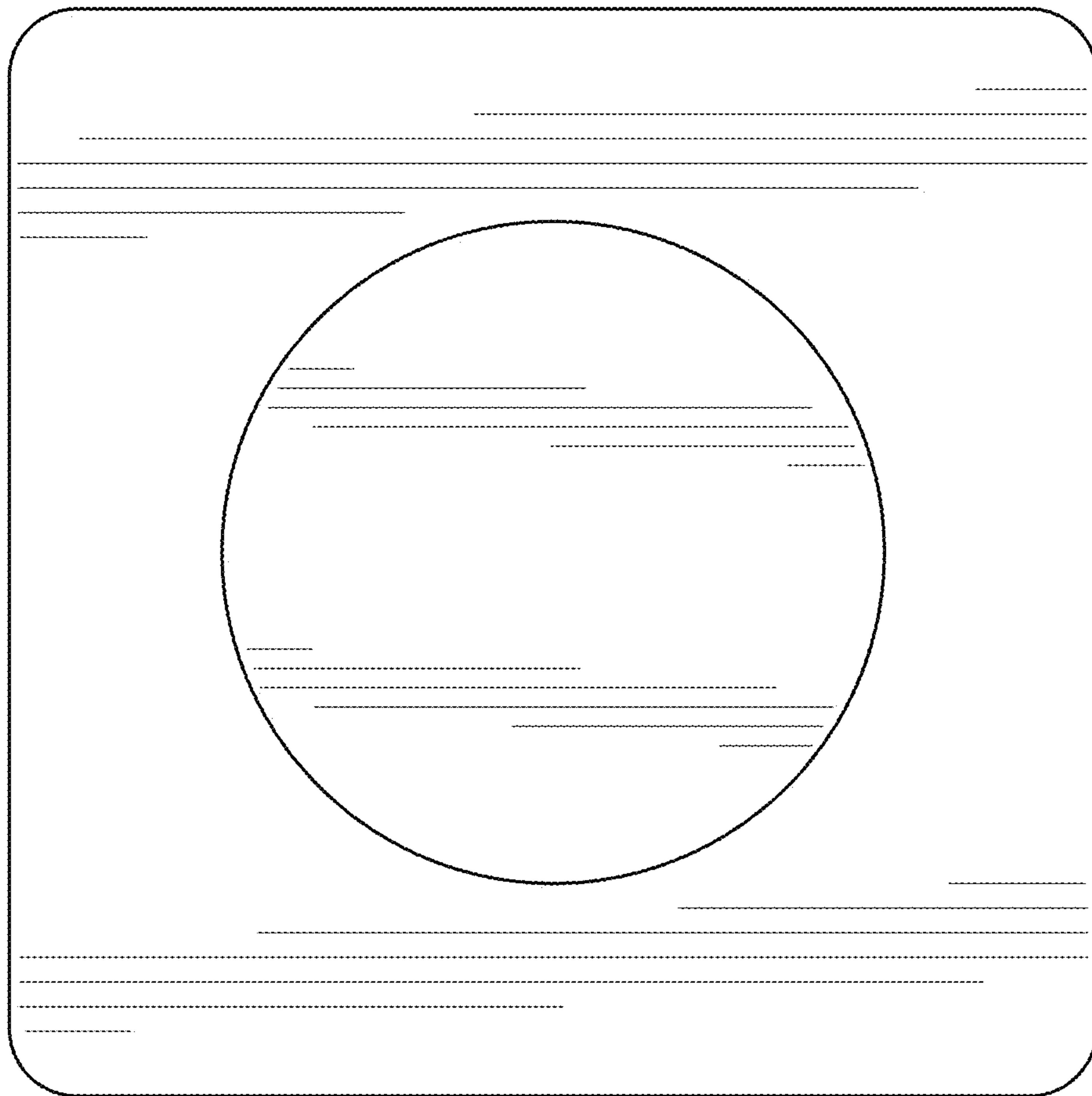

FIG. 14

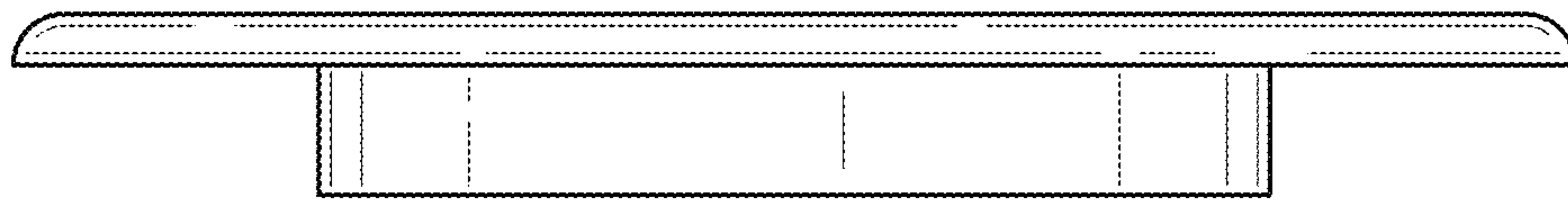

FIG. 15

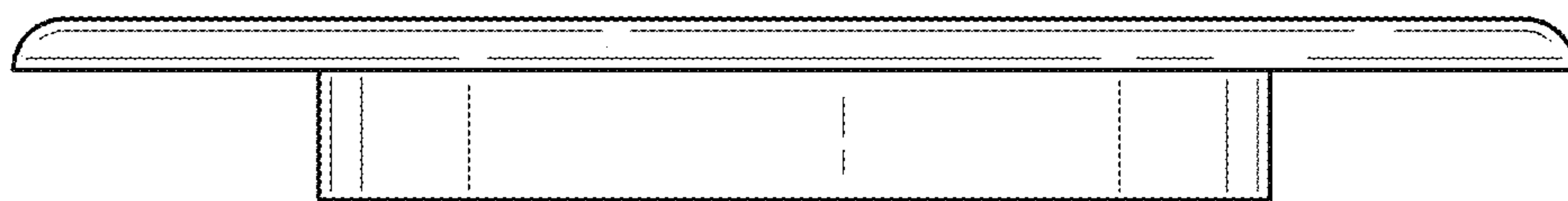

FIG. 16

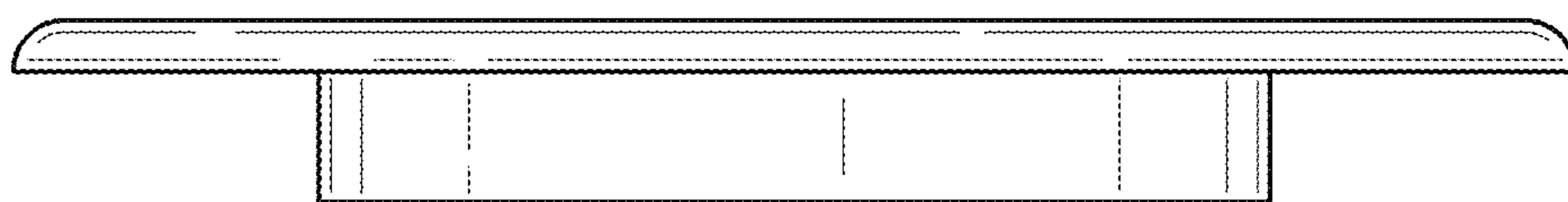

FIG. 17

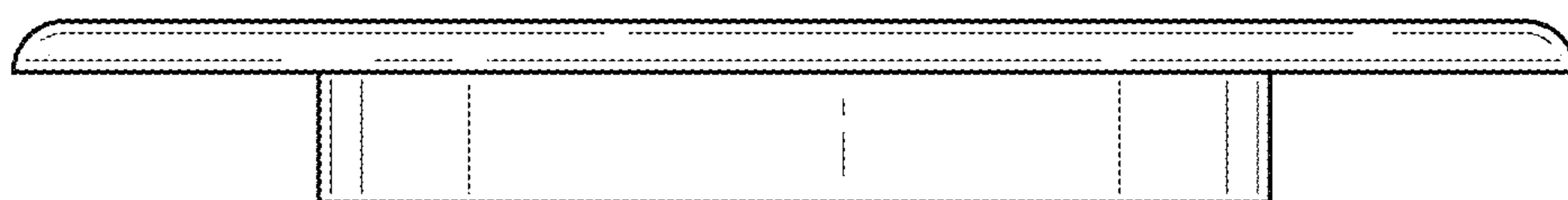

FIG. 18

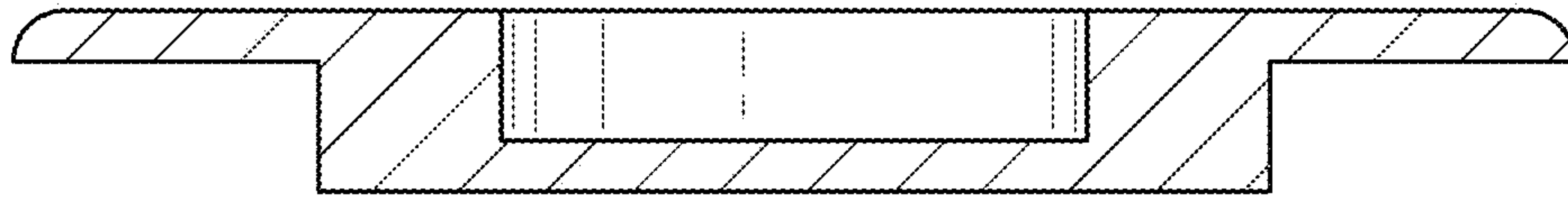

FIG. 19

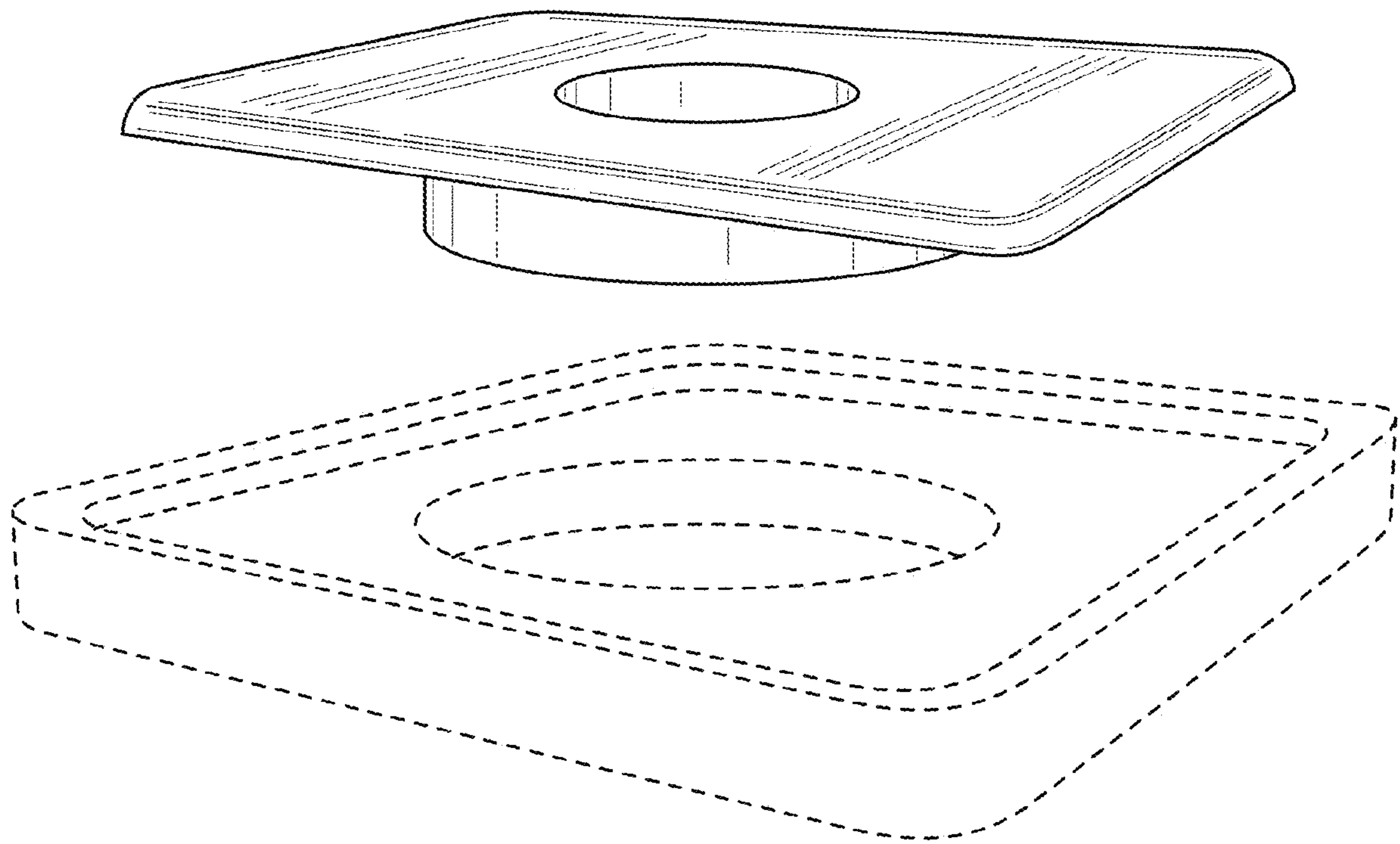

FIG. 20