



US00D894764S

(12) **United States Design Patent** (10) **Patent No.:** **US D894,764 S**  
**Nakamura et al.** (45) **Date of Patent:** **\*\* Sep. 1, 2020**

(54) **HUMIDITY SENSOR**

(56) **References Cited**

(71) Applicant: **MITSUMI ELECTRIC CO., LTD.**,  
Tokyo (JP)

U.S. PATENT DOCUMENTS

(72) Inventors: **Akira Nakamura**, Tama (JP);  
**Taketomo Nakane**, Tama (JP)

D317,876 S *	7/1991	Huen	.....	D10/52
D408,306 S *	4/1999	Cross	.....	D10/103
D456,787 S *	5/2002	Wasada	.....	D13/182
D549,601 S *	8/2007	Chan	.....	D10/52
D675,543 S *	2/2013	Brooking	.....	D10/56
D717,183 S *	11/2014	Herzl	.....	D10/53
D750,992 S *	3/2016	Perez	.....	D10/104.1
D756,248 S *	5/2016	Rosenberg	.....	D10/52
D830,861 S *	10/2018	McNealy	.....	D10/56
D849,570 S *	5/2019	Sakalowsky	.....	D10/52
D860,829 S *	9/2019	Yun	.....	D10/53
D876,249 S *	2/2020	Bee	.....	D10/53

(73) Assignee: **MINEBEA MITSUMI Inc.**, Nagano  
(JP)

(\*\*) Term: **15 Years**

(21) Appl. No.: **35/507,003**

(22) Filed: **Dec. 21, 2018**

\* cited by examiner

(80) **Hague Agreement Data**

*Primary Examiner* — George D. Kirschbaum

Int. Filing Date: **Dec. 21, 2018**

*Assistant Examiner* — Joseph J Kukella

Int. Reg. No.: **DM/201370**

(74) *Attorney, Agent, or Firm* — IPUSA, PLLC

Int. Reg. Date: **Dec. 21, 2018**

Int. Reg. Pub. Date: **Jun. 28, 2019**

(57) **CLAIM**

(30) **Foreign Application Priority Data**

The ornamental design for a humidity sensor, as shown and described.

Jun. 27, 2018 (JP) ..... 2018-014187

Oct. 30, 2018 (JP) ..... 2018-023870

**DESCRIPTION**

(51) **LOC (12) Cl.** ..... **10-05**

(52) **U.S. Cl.**

USPC ..... **D10/56**

(58) **Field of Classification Search**

USPC ..... D10/52-56, 104.1, 104.2, 106.1-106.95,  
D10/108, 121, 123-125

CPC ..... G08B 17/00; G08B 17/06; G08B 17/10;  
G08B 17/11; G08B 17/12; G08B 17/103;  
G08B 17/107; G08B 21/02; G08B  
21/0202; G08B 21/0205; G08B 21/182

See application file for complete search history.

2. Humidity sensor

2.1 : Perspective

2.2 : Top

2.3 : Cross-section view taken along line 2.3-2.3 in Fig. 2.2

2.4 : Cross-section view taken along line 2.4-2.4 in Fig. 2.2.

In the drawings, the broken lines represent portions of the humidity sensor that form no part of the claimed design; all sides not disclosed in the drawings form no part of the claimed design.

**1 Claim, 4 Drawing Sheets**

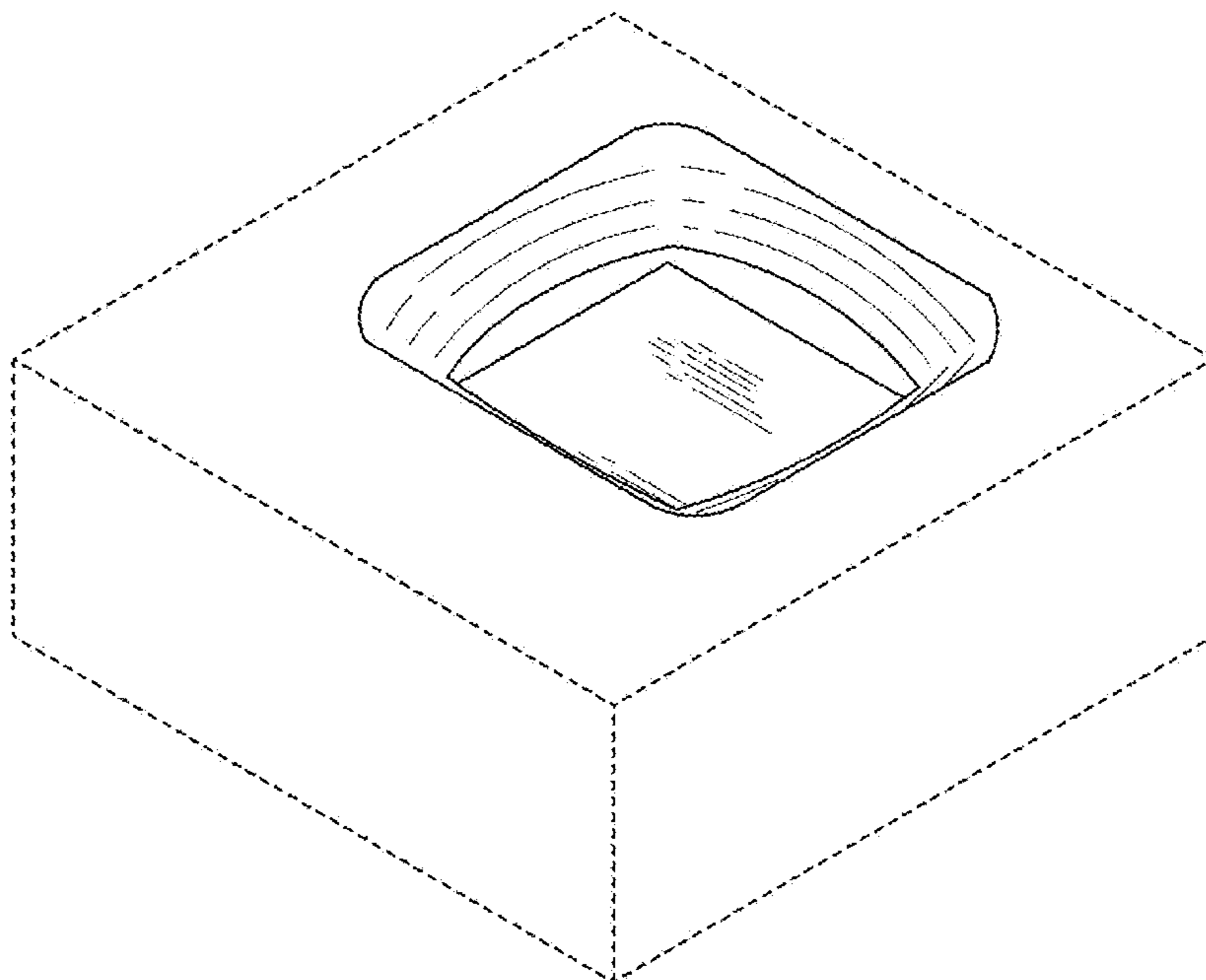

2.1

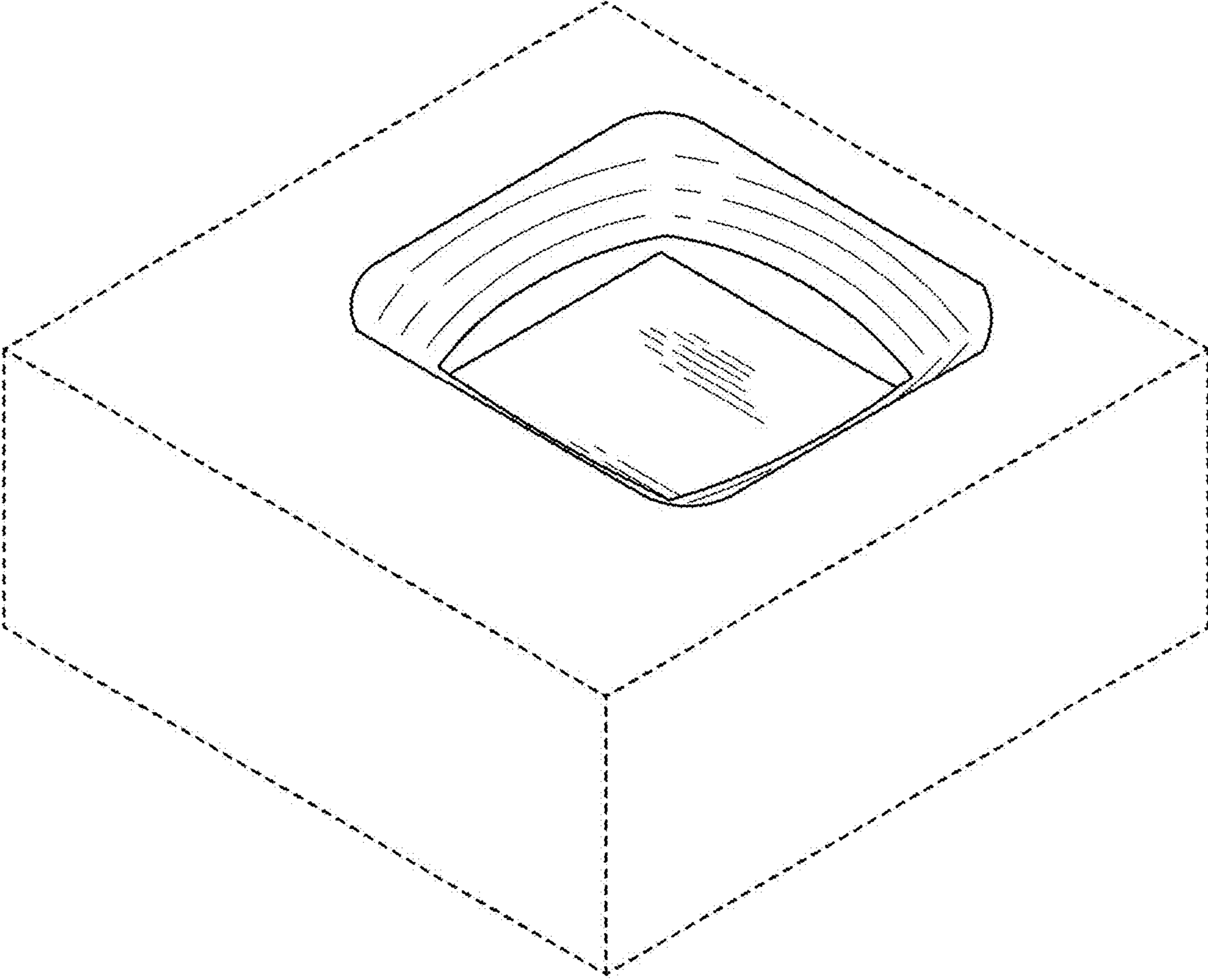

2.2

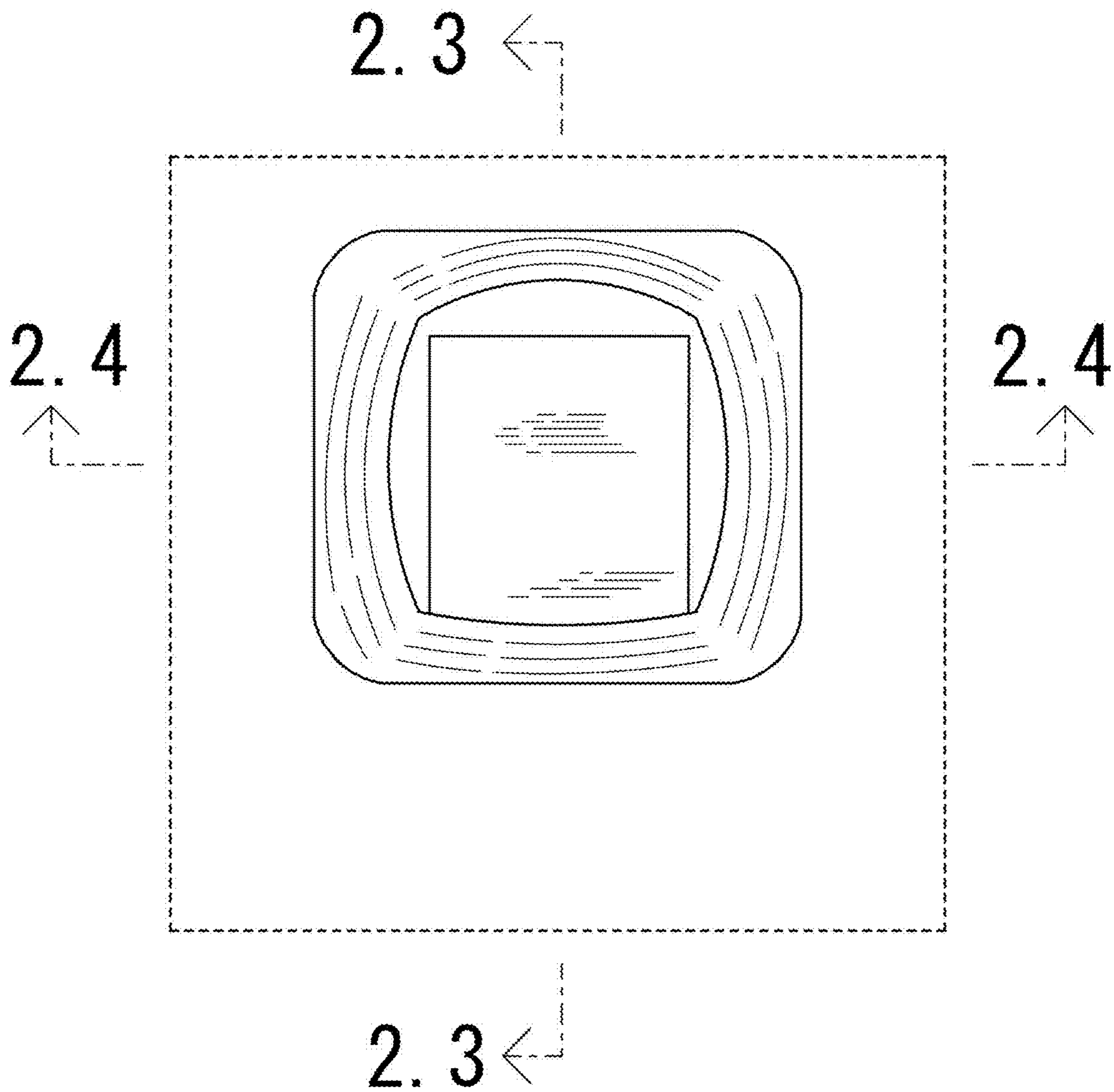

2.3

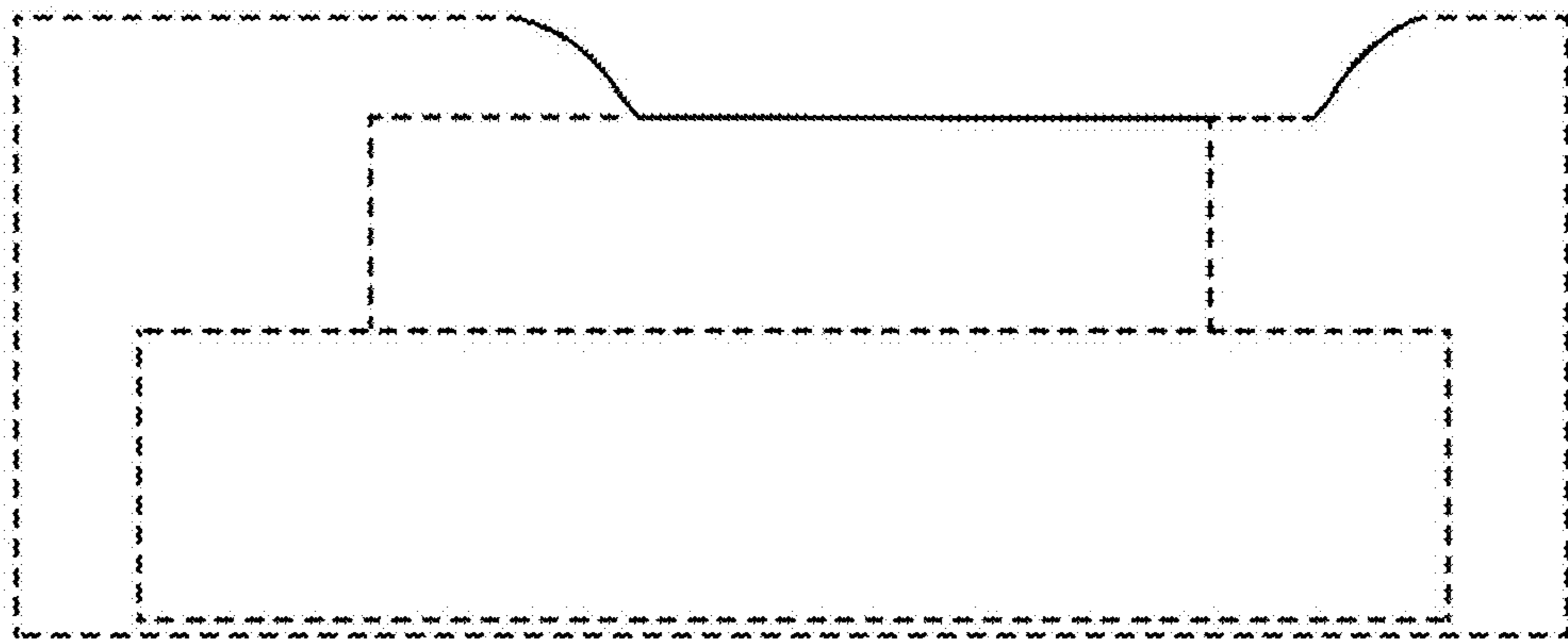

2.4

