



US00D894519S

(12) **United States Design Patent** (10) **Patent No.:** **US D894,519 S**  
**Wenjing et al.** (45) **Date of Patent:** **\*\* Aug. 25, 2020**

(54) **PERSONNEL LIFT VEHICLE** 5,203,425 A 4/1993 Wehmeyer  
5,273,132 A 12/1993 Sasaki et al.  
(71) Applicant: **Big Lift, LLC**, Lombard, IL (US) 5,322,408 A 6/1994 Wooden  
5,425,433 A 6/1995 Huber  
(72) Inventors: **Wu Wenjing**, Hangzhou (CN); **Weng Lijian**, Hangzhou (CN); **Wang Zheng**, Hangzhou (CN); **William John Pedriana**, Elm Grove, WI (US) 5,461,736 A 10/1995 Carpenter et al.  
5,755,306 A 5/1998 Kraemer et al.  
5,803,204 A 9/1998 White et al.  
5,941,341 A 8/1999 Gillis et al.  
6,000,502 A \* 12/1999 Leasor ..... B66F 11/04 187/222

(73) Assignee: **Big Lift, LLC**, Lombard, IL (US) (Continued)

(\*\*) Term: **15 Years**

FOREIGN PATENT DOCUMENTS

(21) Appl. No.: **29/644,775**

DE 102010036409 1/2012  
FR 2717456 A1 9/1995

(22) Filed: **Apr. 20, 2018**

(Continued)

**Related U.S. Application Data**

*Primary Examiner* — Gino Colan

(63) Continuation of application No. 15/933,664, filed on Mar. 23, 2018.

(74) *Attorney, Agent, or Firm* — Cook Alex Ltd.

(51) **LOC (12) Cl.** ..... **12-05**

(57) **CLAIM**

(52) **U.S. Cl.**

We claim the ornamental design for a personnel lift vehicle, as shown and described.

USPC ..... **D34/34**

**DESCRIPTION**

(58) **Field of Classification Search**

USPC ..... D34/34, 28, 31; 187/230, 226, 148; 180/19.3

CPC ..... B66F 11/04; B66F 11/044; B66F 11/046; B66F 17/006; B66F 9/127; B66F 3/24; B66F 1/06; B66F 3/247; B66F 9/22

See application file for complete search history.

FIG. 1 is a right front perspective view of a personnel lift vehicle showing our new design;  
FIG. 2 is a left front perspective view thereof;  
FIG. 3 is a right rear perspective view thereof;  
FIG. 4 is a left rear perspective view thereof;  
FIG. 5 is a front elevational view thereof;  
FIG. 6 is a rear elevational view thereof;  
FIG. 7 is a left side elevational view thereof;  
FIG. 8 is a right side elevational view thereof;  
FIG. 9 is a top plan view thereof; and,  
FIG. 10 is a bottom plan view thereof.

(56) **References Cited**

**U.S. PATENT DOCUMENTS**

1,759,424 A 6/1928 Strauss  
2,762,659 A 9/1956 Harlan et al.  
3,180,450 A 4/1965 Crager et al.  
3,344,885 A 10/1967 Rasmussen  
3,417,841 A 12/1968 Lebre  
3,666,046 A 5/1972 Meinecke et al.  
5,121,816 A 6/1992 Curtin

The broken lines shown in the figures are for the purpose of illustrating portions of the personnel lift device and form no part of the claimed design.

**1 Claim, 10 Drawing Sheets**

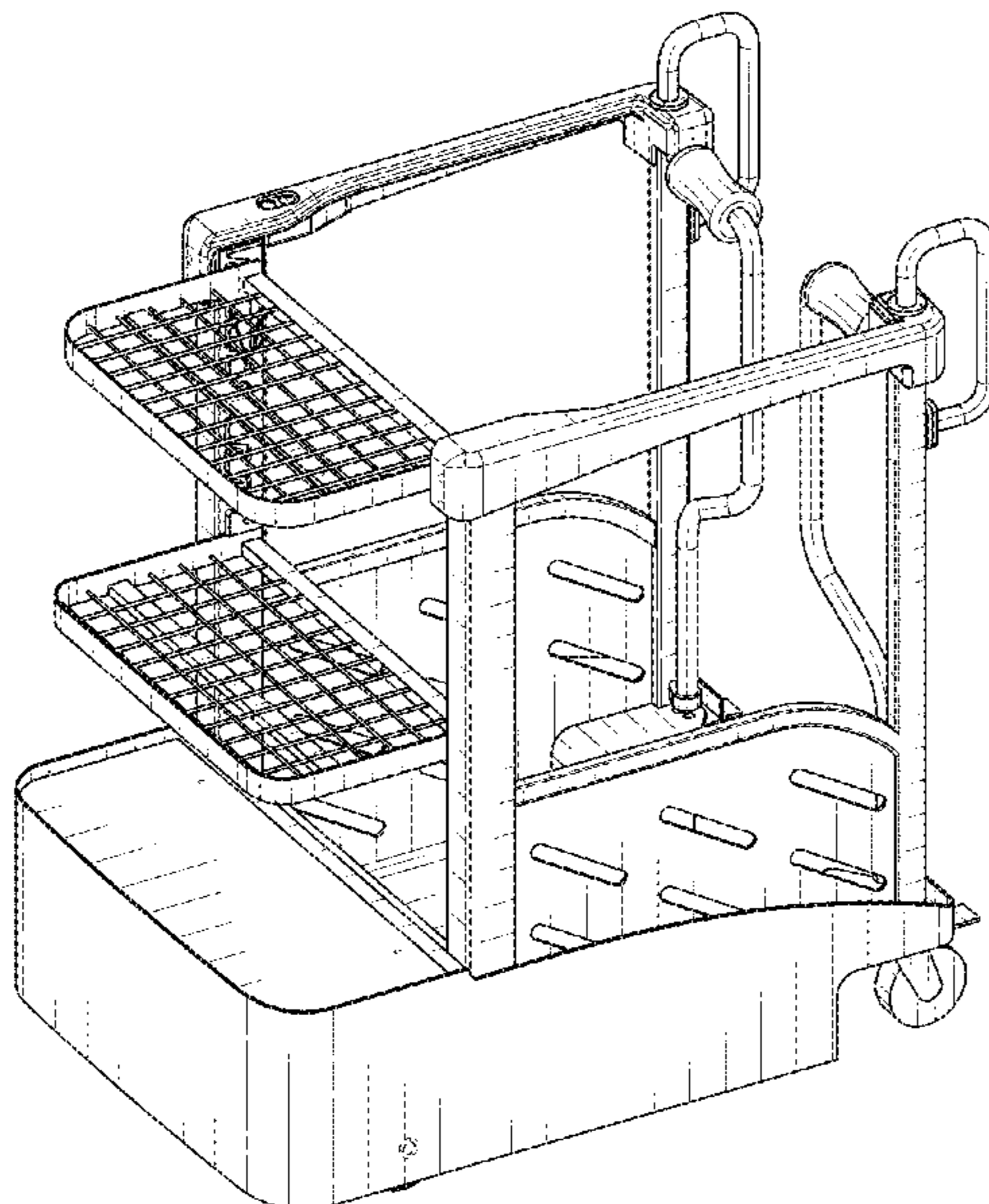

(56)

**References Cited**

U.S. PATENT DOCUMENTS

6,174,124	B1 *	1/2001	Haverfield .....	B66F 9/06 182/148
6,241,047	B1 *	6/2001	Gilliland .....	B66F 9/06 180/19.3
7,140,467	B2	11/2006	Cook	
7,753,169	B1	7/2010	Kurtz	
7,828,115	B2	11/2010	Sayles	
D684,333	S *	6/2013	Knie .....	D34/34
8,863,899	B2	10/2014	Solhjem et al.	
8,985,275	B2	3/2015	Solhjem et al.	
D730,614	S *	5/2015	Wu .....	D34/34
9,108,831	B2 *	8/2015	Beji .....	B66F 11/04
9,212,038	B1	12/2015	Presti	
9,440,830	B2 *	9/2016	Wu .....	B66F 11/04
9,914,626	B2 *	3/2018	Shugen .....	B66F 11/04
10,160,629	B2 *	12/2018	Wenjing .....	B66F 11/04
D882,204	S *	4/2020	Wenjing .....	D34/34
2007/0086880	A1	4/2007	Jordan	
2013/0168185	A1	7/2013	Huang et al.	

FOREIGN PATENT DOCUMENTS

FR	2984292	A1	6/2013
GB	135834	A	7/1920
GB	885824	A	12/1961
GB	2493487	A	2/2013
WO	WO 99/41186		8/1999

\* cited by examiner

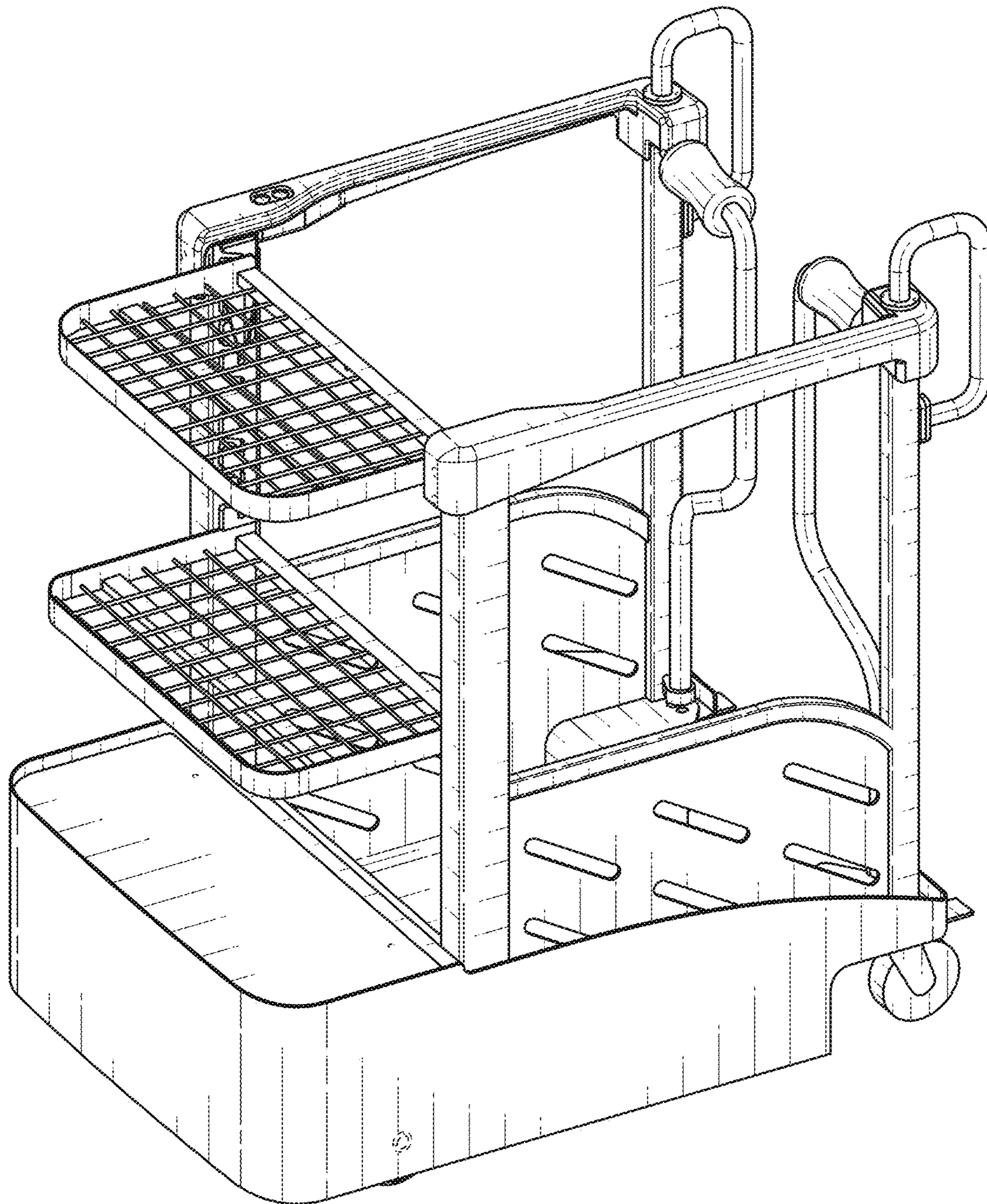

FIG. 1

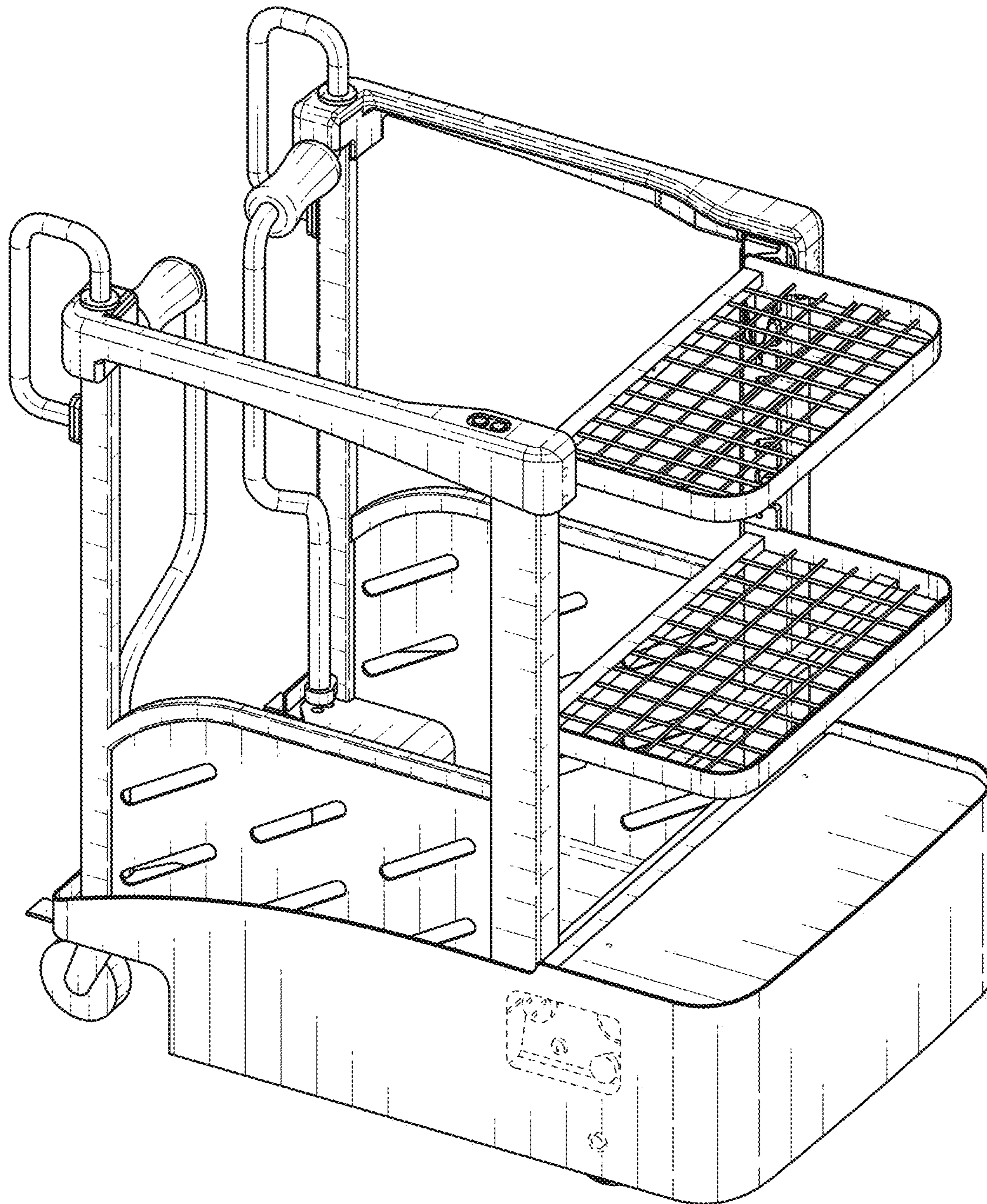

FIG. 2

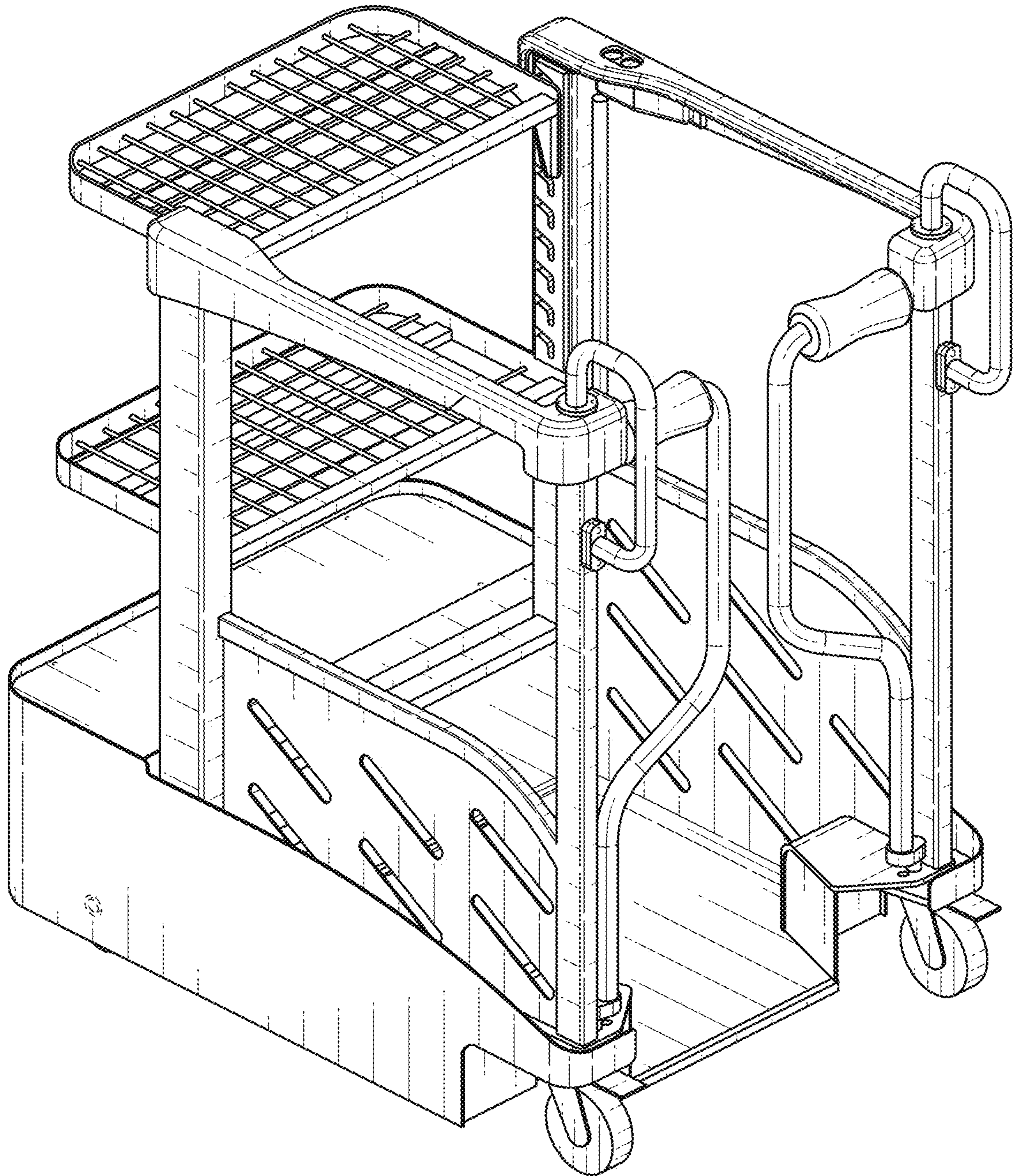

FIG. 3

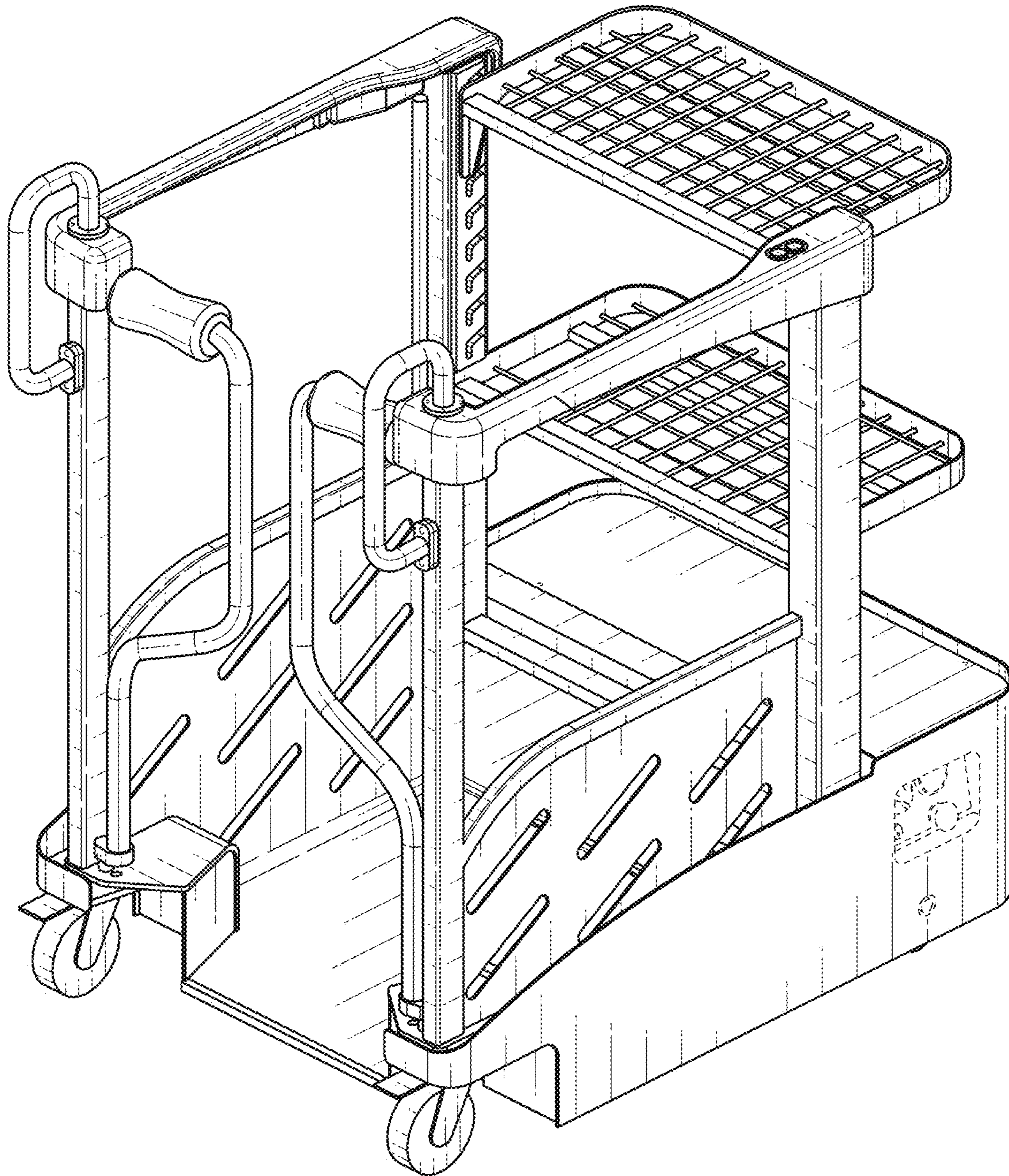

FIG. 4

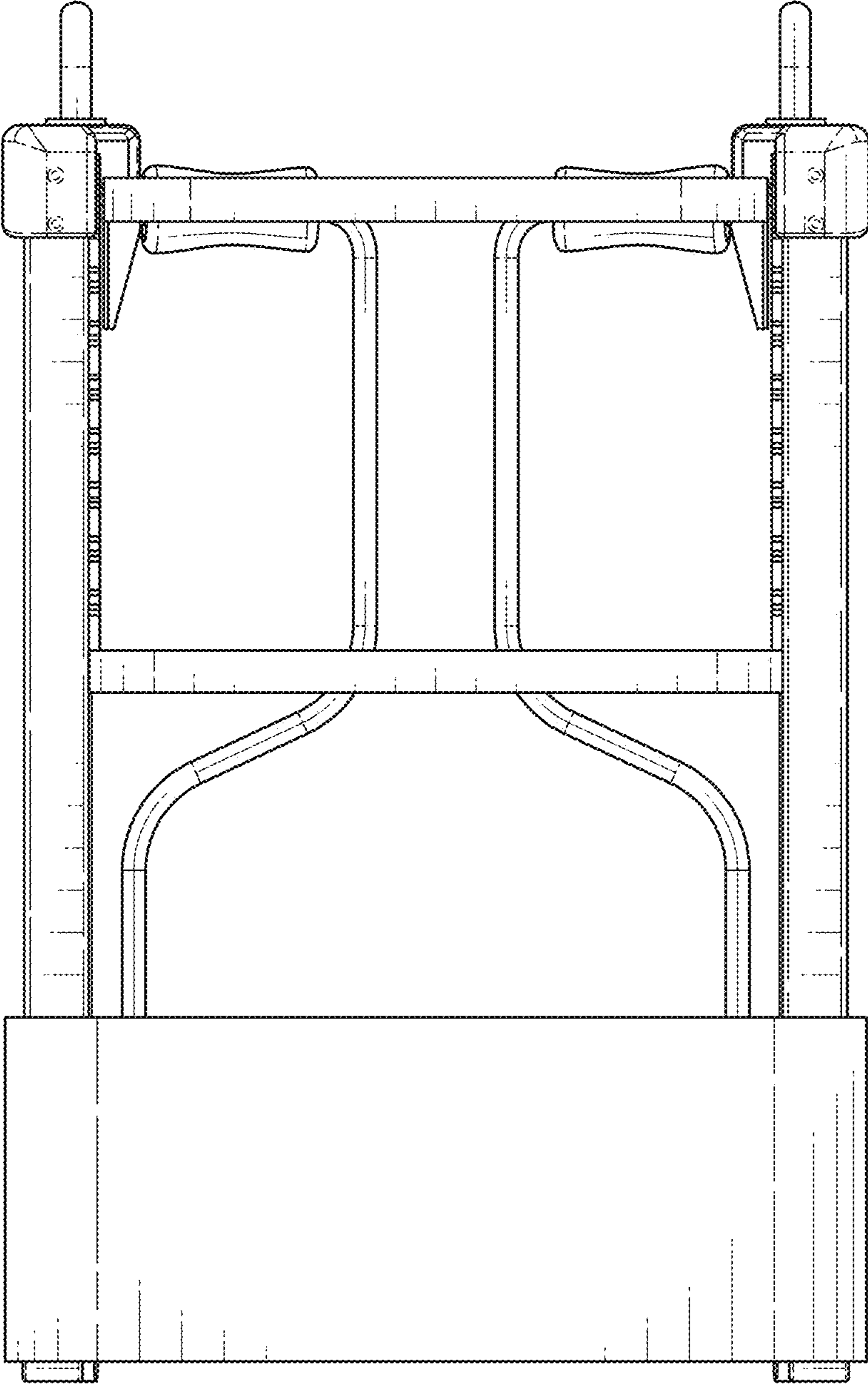

FIG. 5

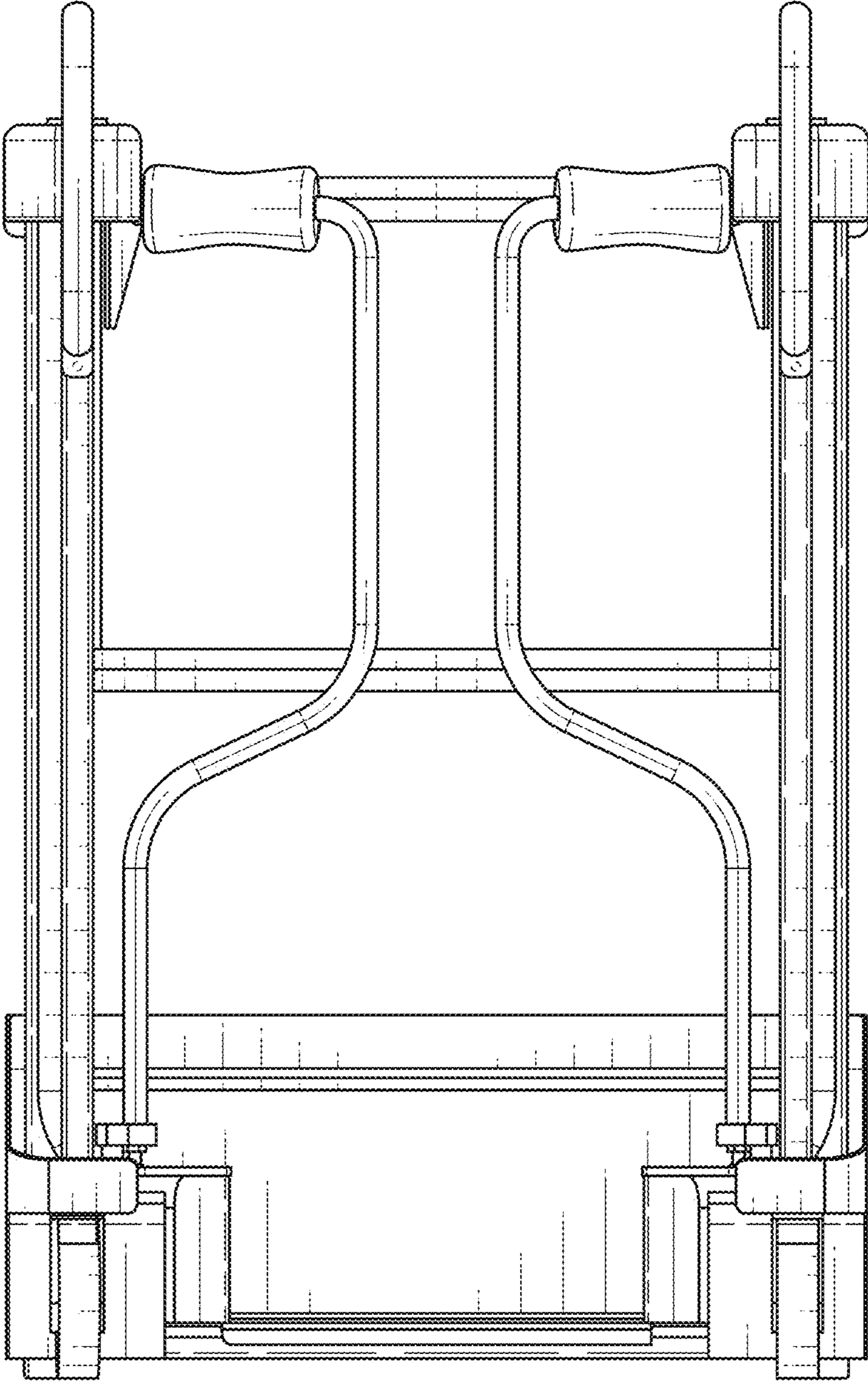

FIG. 6



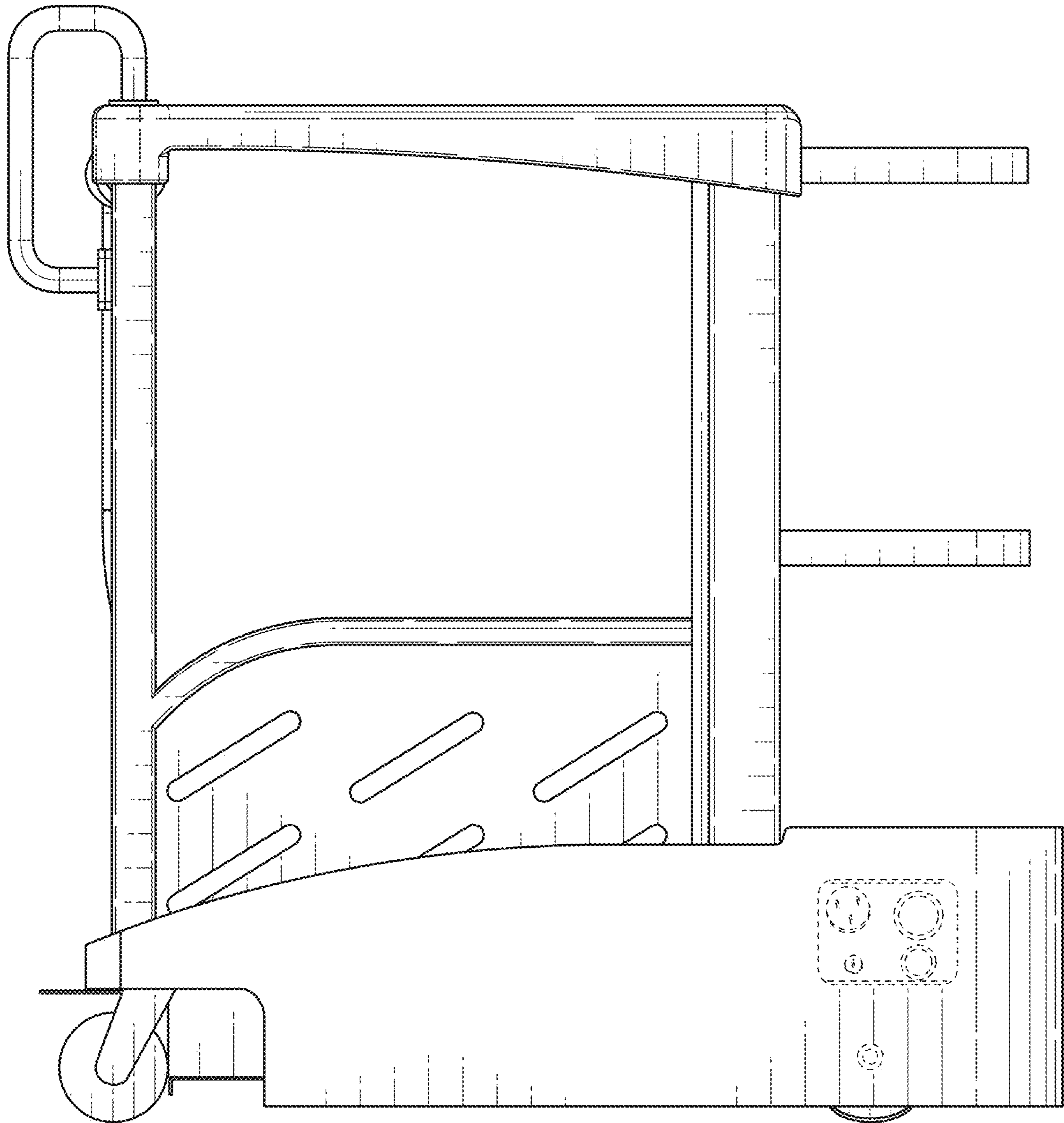

FIG. 7

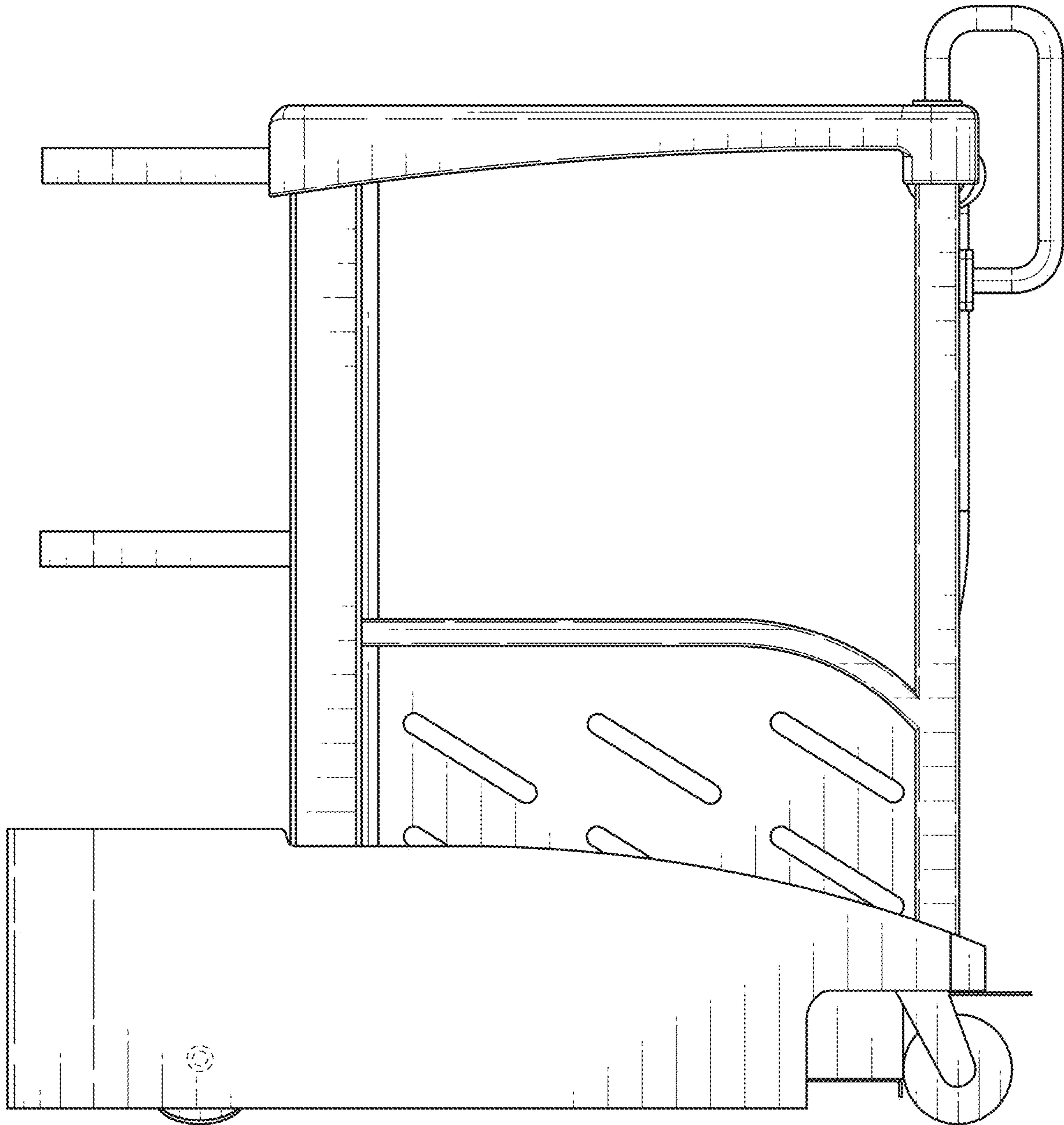

FIG. 8

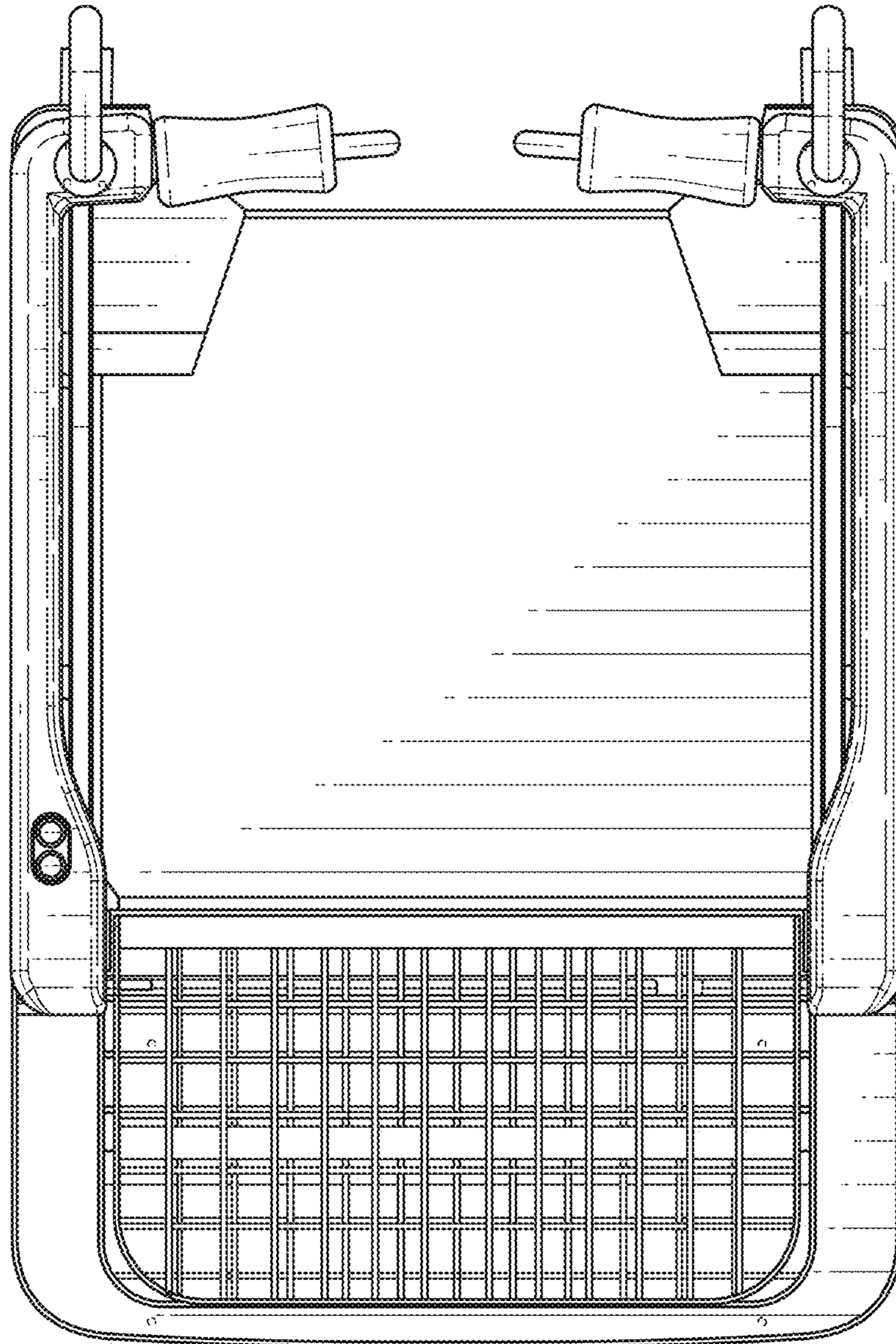

FIG. 9

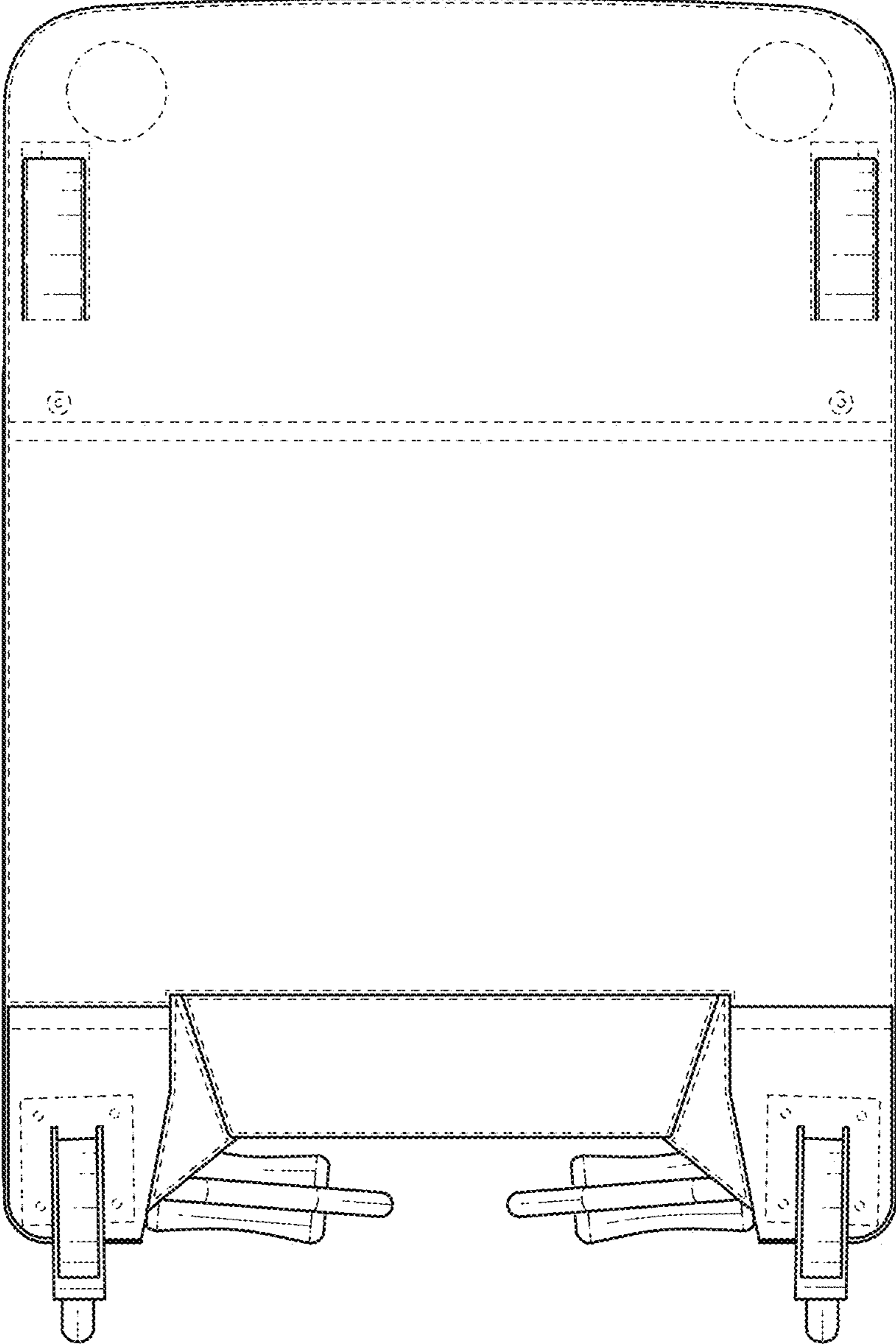

FIG. 10