



US00D894053S

(12) **United States Design Patent** (10) **Patent No.:** **US D894,053 S**
Buell et al. (45) **Date of Patent:** **** Aug. 25, 2020**

(54) **MOTORCYCLE**
(71) Applicant: **FUELL Inc.**, New York, NY (US)
(72) Inventors: **Erik Buell**, Mukwonago, WI (US);
Ryan Hahn, New York, NY (US);
Artem Smirnov, Minskaya Region (BY)
(73) Assignee: **FUELL Inc.**, New York, NY (US)
(**) Term: **15 Years**
(21) Appl. No.: **29/681,949**
(22) Filed: **Feb. 28, 2019**
(51) **LOC (12) Cl.** **12-11**
(52) **U.S. Cl.**
USPC **D12/114**
(58) **Field of Classification Search**
USPC D12/114, 110, 107, 117, 126, 182, 186
CPC ... B62J 17/00; B62J 17/02; B62J 17/04; B62J
23/00; B62J 6/02; B62K 11/00; B62K
11/04
See application file for complete search history.

D683,274 S *	5/2013	Yanagita	D12/126
D689,411 S *	9/2013	Tsukui	D12/126
D689,800 S *	9/2013	Futamata	D12/126
D690,625 S *	10/2013	Futamata	D12/126
D690,627 S *	10/2013	Tsukui	D12/126
D694,157 S *	11/2013	Katagiri	D12/126
D695,157 S *	12/2013	Tsukui	D12/126
D711,291 S *	8/2014	Futamata	D12/114
D712,314 S *	9/2014	Katagiri	D12/114
D733,011 S *	6/2015	Nishimoto	D12/126
D776,017 S *	1/2017	Takigawa	D12/114
D782,369 S *	3/2017	Fujimoto	D12/114
D786,141 S *	5/2017	Tachibana	D12/114
D795,750 S *	8/2017	Futamata	D12/114
D803,107 S *	11/2017	Petersson	D12/126
D826,790 S *	8/2018	Sears, Jr.	D12/126
D840,279 S *	2/2019	Tako	D12/126

* cited by examiner

Primary Examiner — Michelle E. Wilson
Assistant Examiner — Clese Moore, Jr.
(74) *Attorney, Agent, or Firm* — Banner & Witcoff, Ltd.

(57) **CLAIM**

The ornamental design for a motorcycle, as shown and described.

DESCRIPTION

FIG. 1 is a front, right perspective view of a motorcycle showing our new design; and, FIG. 2 is a right side view thereof. The broken lines immediately adjacent to the shaded area define the bounds of the claimed design and form no part thereof. The broken lines depicting the remainder of the motorcycle show features that form no part of the claimed design.

1 Claim, 2 Drawing Sheets

(56) **References Cited**

U.S. PATENT DOCUMENTS

D526,606 S *	8/2006	Ban	D12/182
D538,718 S *	3/2007	Tako	D12/182
D579,834 S *	11/2008	Sawabe	D12/126
D582,822 S *	12/2008	Watanabe	D12/186
D584,662 S *	1/2009	Ichihara	D12/126
D608,260 S *	1/2010	Toriyama	D12/186
D639,218 S *	6/2011	Katagiri	D12/186
D649,915 S *	12/2011	Aiello	D12/110
D674,323 S *	1/2013	Tokumura	D12/126

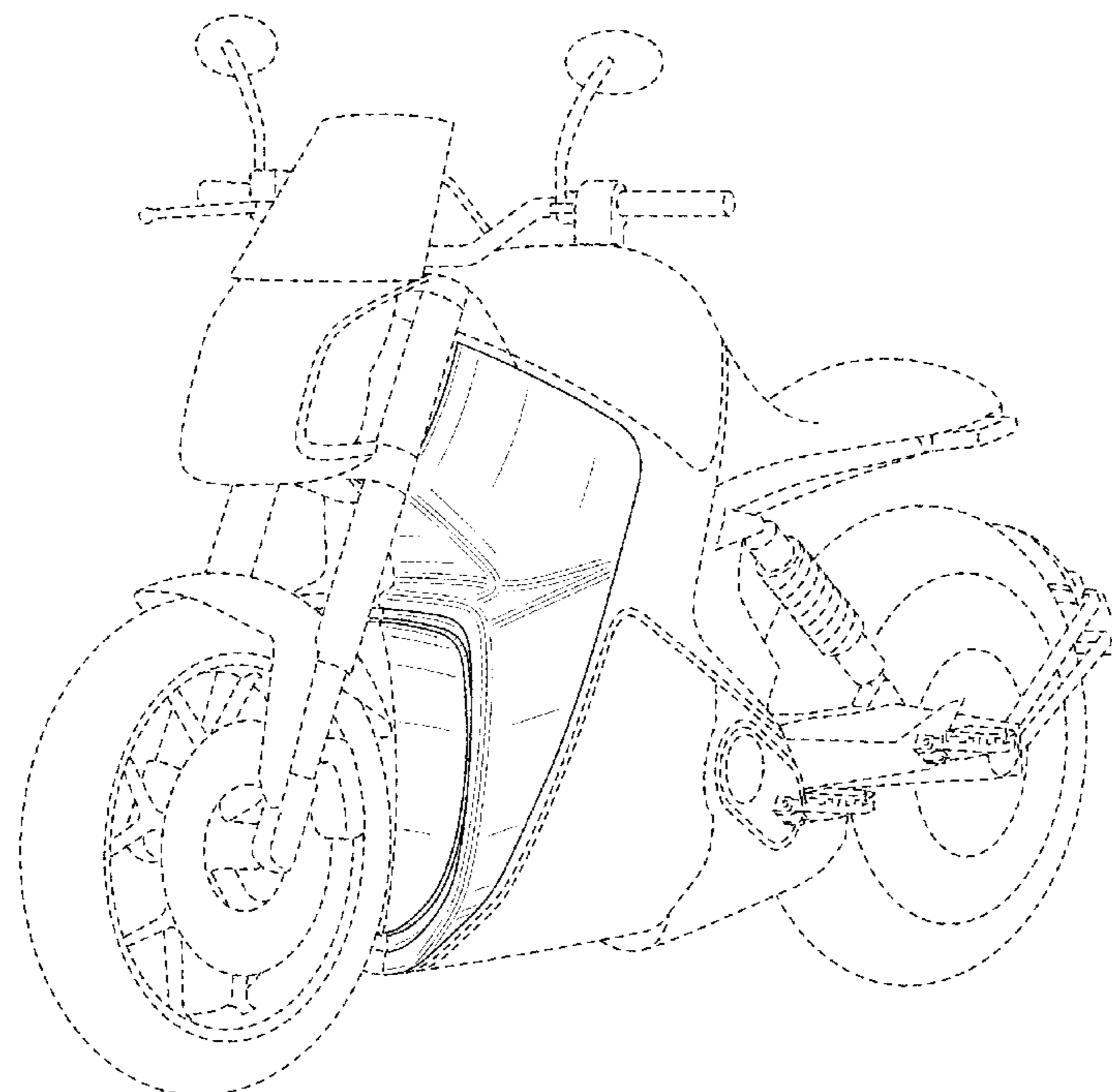

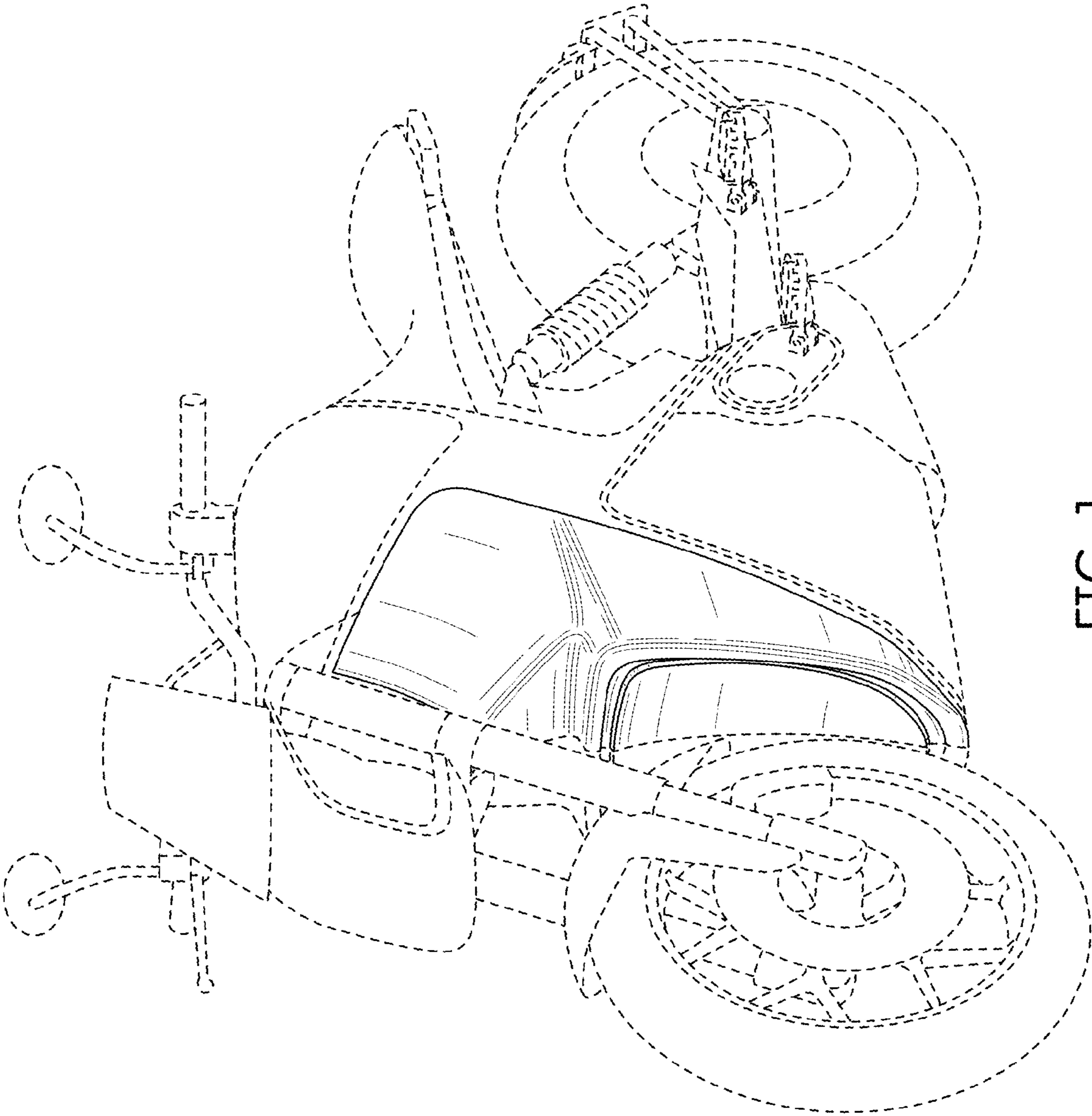

FIG. 1

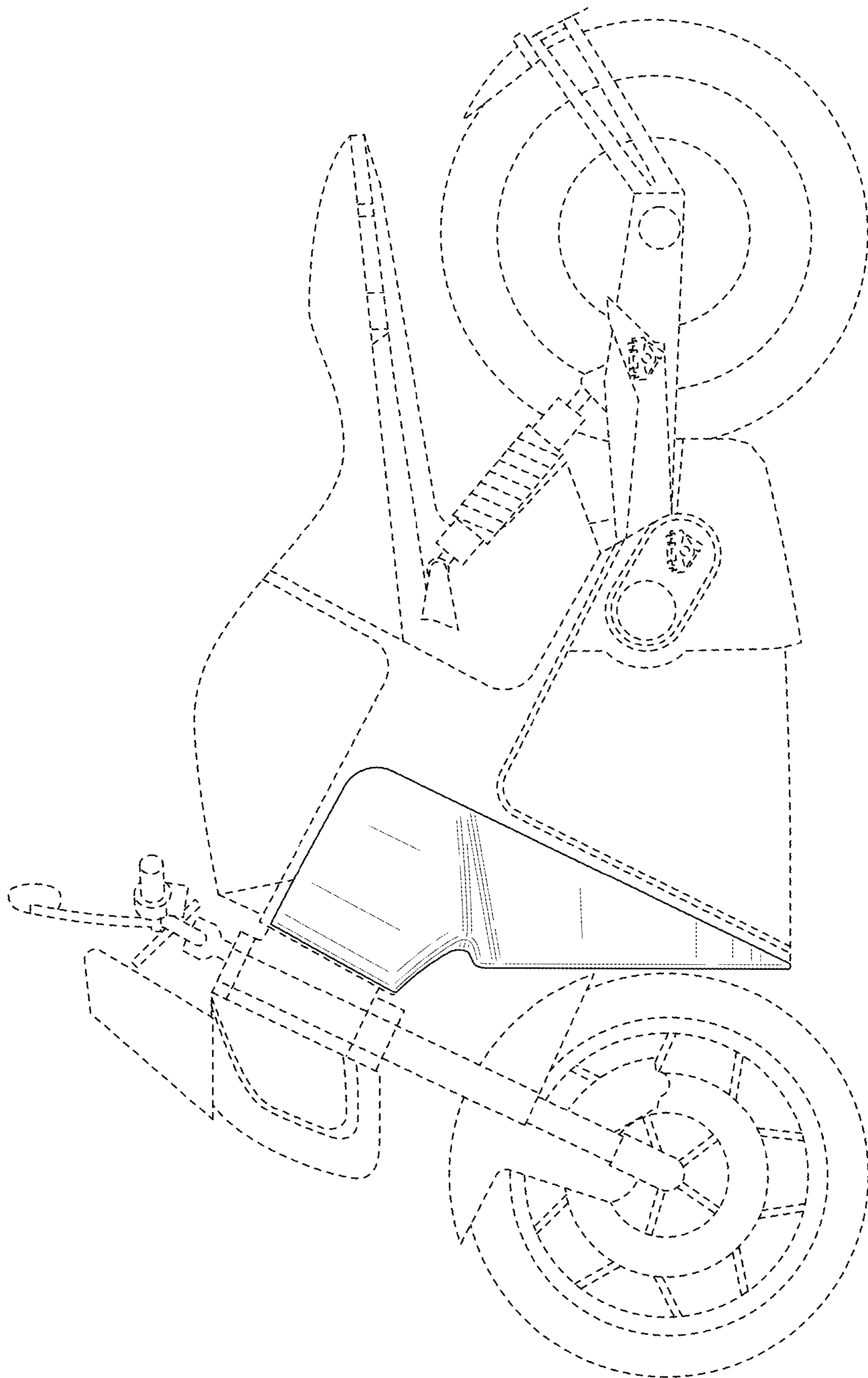

FIG. 2