



US00D894045S

(12) **United States Design Patent**
Frost et al.

(10) **Patent No.:** **US D894,045 S**

(45) **Date of Patent:** **** Aug. 25, 2020**

- (54) **RAIL**
- (71) Applicant: **Conductix, Inc.**, Omaha, NE (US)
- (72) Inventors: **Ryan Frost**, Omaha, NE (US); **Keith Forman**, Troy, IL (US); **Trevor Howe**, Omaha, NE (US)
- (73) Assignee: **Conductix, Inc.**, Omaha, NE (US)
- (**) Term: **15 Years**
- (21) Appl. No.: **29/649,820**
- (22) Filed: **Jun. 1, 2018**
- (51) **LOC (12) Cl.** **13-03**
- (52) **U.S. Cl.**
USPC **D12/50**
- (58) **Field of Classification Search**
USPC D12/49, 50; D13/128; D25/38.1, 41.1, D25/42, 43, 44, 119, 120, 121, 122-126, D25/128, 136, 164, 199; D34/28, 29, 35
CPC B65G 47/52; B65G 47/66; B65G 9/008; B65G 21/2072; B65G 2201/02; B65G 17/08; E04F 11/18; E04F 11/1802; E04F 11/1818; E04F 11/1836; B60M 1/30; B22D 19/04; E01B 5/00; E01B 5/02; E01B 5/04; E01B 5/06; E01B 5/08; E01B 5/10; E01B 5/12; E01B 5/14
See application file for complete search history.

(56) **References Cited**

U.S. PATENT DOCUMENTS

D26,289 S	*	11/1896	Rebmann	D34/35
D27,217 S	*	6/1897	Heinle	D12/50
D32,406 S	*	3/1900	Hazard	D12/50
D33,474 S	*	10/1900	Kofske	D12/50
749,183 A	*	1/1904	Guynan	E01B 31/18 238/148

945,502 A	*	1/1910	Enquist	B60M 1/30 191/22 R
1,395,805 A	*	11/1921	Feibermann	E01B 5/08 238/148
1,463,319 A	*	7/1923	Hohman, Sr.	E01B 5/18 238/21
1,525,355 A	*	2/1925	Anderson	E01B 31/04 33/411
1,666,167 A	*	4/1928	Connolly	E01B 5/10 104/306
1,739,591 A	*	12/1929	Holzel	B60M 1/04 191/30
2,035,445 A	*	3/1936	Banks	B60M 1/307 191/32
2,048,367 A	*	7/1936	Banks	B60M 1/307 191/32

(Continued)

FOREIGN PATENT DOCUMENTS

CN	3605053	*	1/2007
CN	302490453	*	7/2013
JP	D237118	*	4/2005

Primary Examiner — Leanne Was-Englehart

(74) *Attorney, Agent, or Firm* — Ryan T. Grace; Advent, LLP

(57) **CLAIM**

The ornamental design for a rail, as shown and described.

DESCRIPTION

FIG. 1 is an end elevation view of a rail.
 FIG. 2 is a bottom view of the rail of FIG. 1.
 FIG. 3 is an isometric view of the rail of FIG. 1; and
 FIG. 4 is another isometric view of the rail of FIG. 1.
 Portions of FIGS. 1 through 4 are shown in broken and dash-dot-dash boundary lines illustrating portions of the article and environmental subject matter that form no part of the claimed design. The appearance of any portion of the rail between the break lines forms no part of the claimed design.

1 Claim, 4 Drawing Sheets

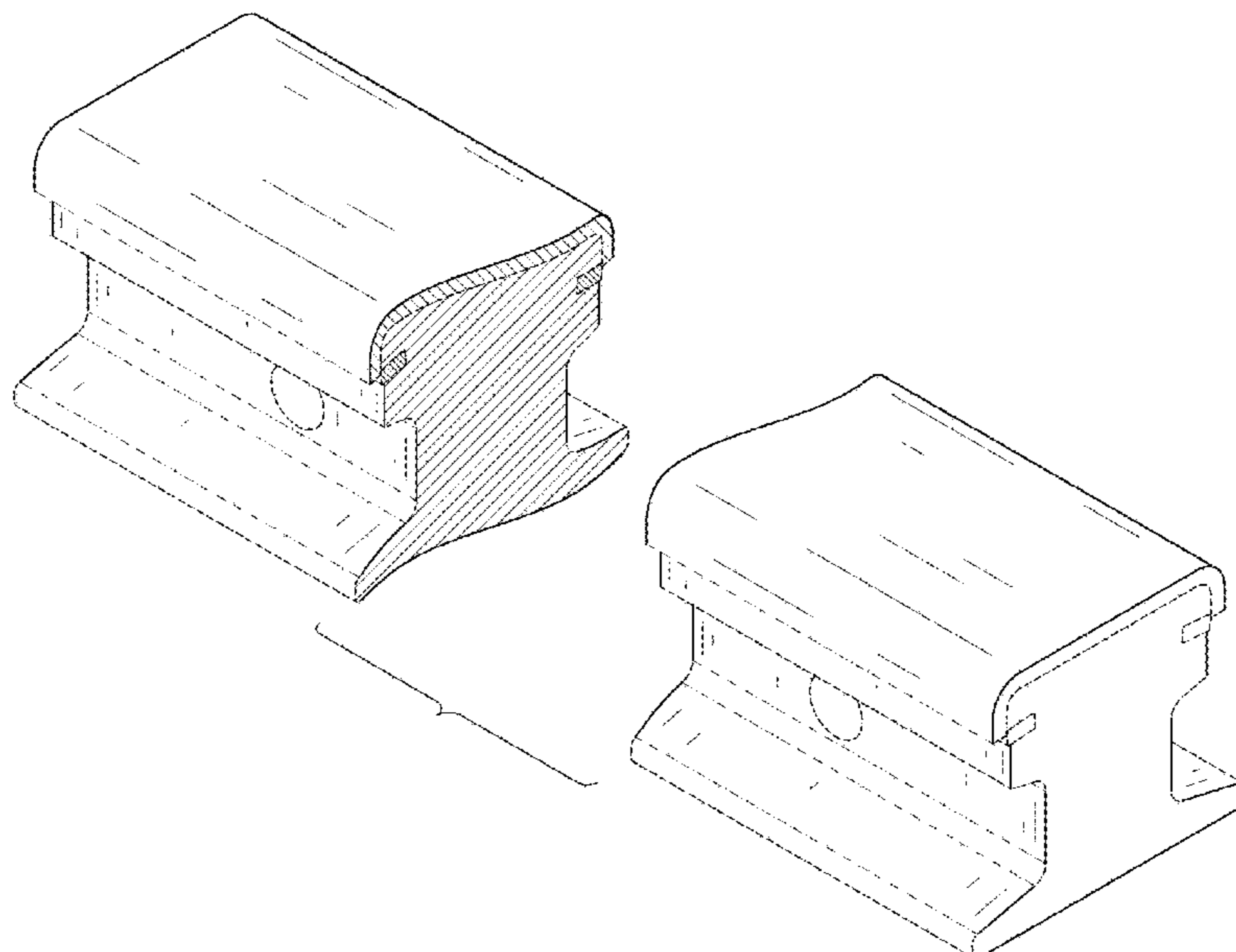

(56)

References Cited

U.S. PATENT DOCUMENTS

2,853,775	A *	9/1958	Drake	E01B 31/12 29/558	7,874,412	B2 *	1/2011	Woempner	B60M 1/302 191/22 DM
3,463,290	A *	8/1969	Tajima	B66B 23/24 198/337	D640,600	S *	6/2011	Kishi	D12/50
3,806,672	A *	4/1974	Landis	B60M 1/04 191/30	7,954,611	B2 *	6/2011	Woempner	B21K 9/00 191/22 DM
3,885,655	A *	5/1975	Corl	B60M 1/302 191/29 R	D642,959	S *	8/2011	Kishi	D12/50
4,042,081	A *	8/1977	Pier	B60L 3/04 191/8	D643,337	S *	8/2011	Kishi	D12/50
4,265,401	A *	5/1981	Jackson	E01B 5/18 238/17	D643,338	S *	8/2011	Kishi	D12/50
4,318,462	A *	3/1982	Weinhaus	B60M 1/30 191/30	D644,959	S *	9/2011	Kishi	D12/50
4,692,039	A *	9/1987	Teramachi	F16C 29/00 384/45	D650,143	S *	12/2011	Bhosale	D34/29
5,176,318	A *	1/1993	Young	E01B 5/18 104/242	8,365,899	B2 *	2/2013	McKee	B65G 47/66 198/539
D336,712	S *	6/1993	Ledingham	D18/15	D681,509	S *	5/2013	Remington	D12/50
5,279,397	A *	1/1994	Hartland	B60M 1/302 191/22 DM	9,566,644	B2 *	2/2017	Patrick	B22D 19/04
D353,791	S *	12/1994	Brandan	D12/50	D789,643	S *	6/2017	Pettinga	D34/29
6,012,845	A *	1/2000	Lyon	F16C 29/025 29/898.02	2003/0103697	A1 *	6/2003	Mochizuki	F16C 29/045 384/44
6,279,833	B1 *	8/2001	Schwiede	E01B 5/18 238/17	2006/0182373	A1 *	8/2006	Kawai	F16J 15/406 384/15
6,364,215	B1 *	4/2002	Andre	E01B 25/28 238/122	2013/0098726	A1 *	4/2013	Ciloglu	B60M 1/302 191/29 DM
6,983,834	B1 *	1/2006	Kraudy	B60M 1/302 191/22 DM	2013/0153671	A1 *	6/2013	Bosterling	E01B 9/30 238/349
7,712,591	B2 *	5/2010	Wompner	B60M 1/302 191/22 DM	2015/0376842	A1 *	12/2015	Ellis	E01B 19/00 238/130
					2016/0159618	A1 *	6/2016	Awi Abalo	E01B 5/08 212/299
					2016/0177513	A1 *	6/2016	Ohata	E01B 19/003 238/148
					2016/0186802	A1 *	6/2016	Hashimoto	F16C 32/0648 384/12
					2016/0361762	A1 *	12/2016	Patrick	E01B 5/08
					2018/0154914	A1 *	6/2018	Carmona	E01B 35/00

* cited by examiner

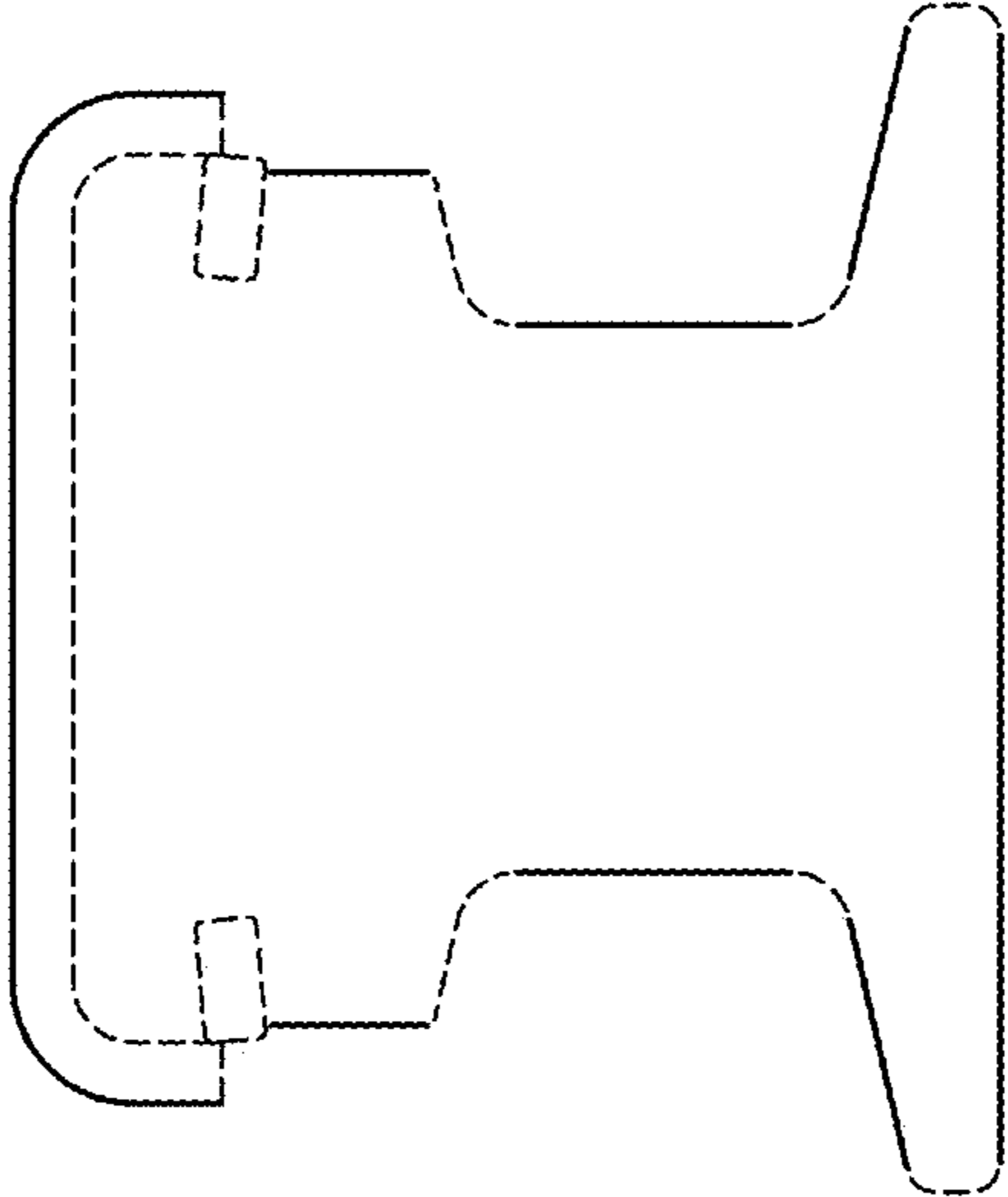

FIG. 1

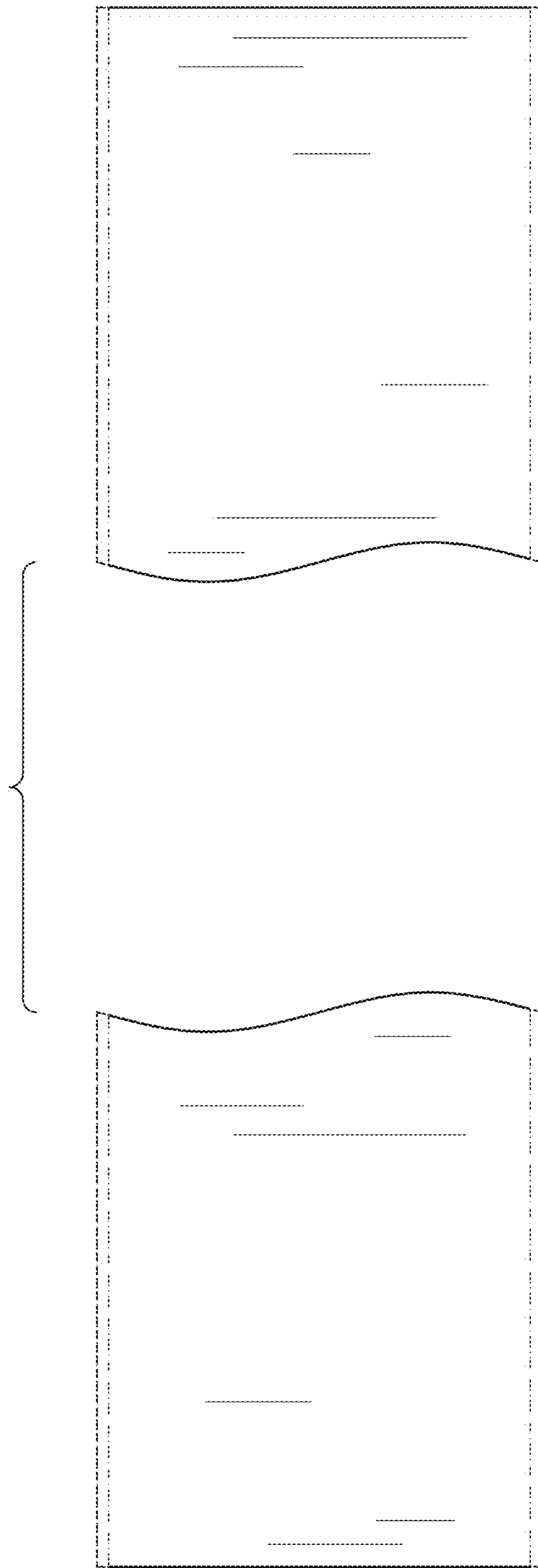

FIG. 2

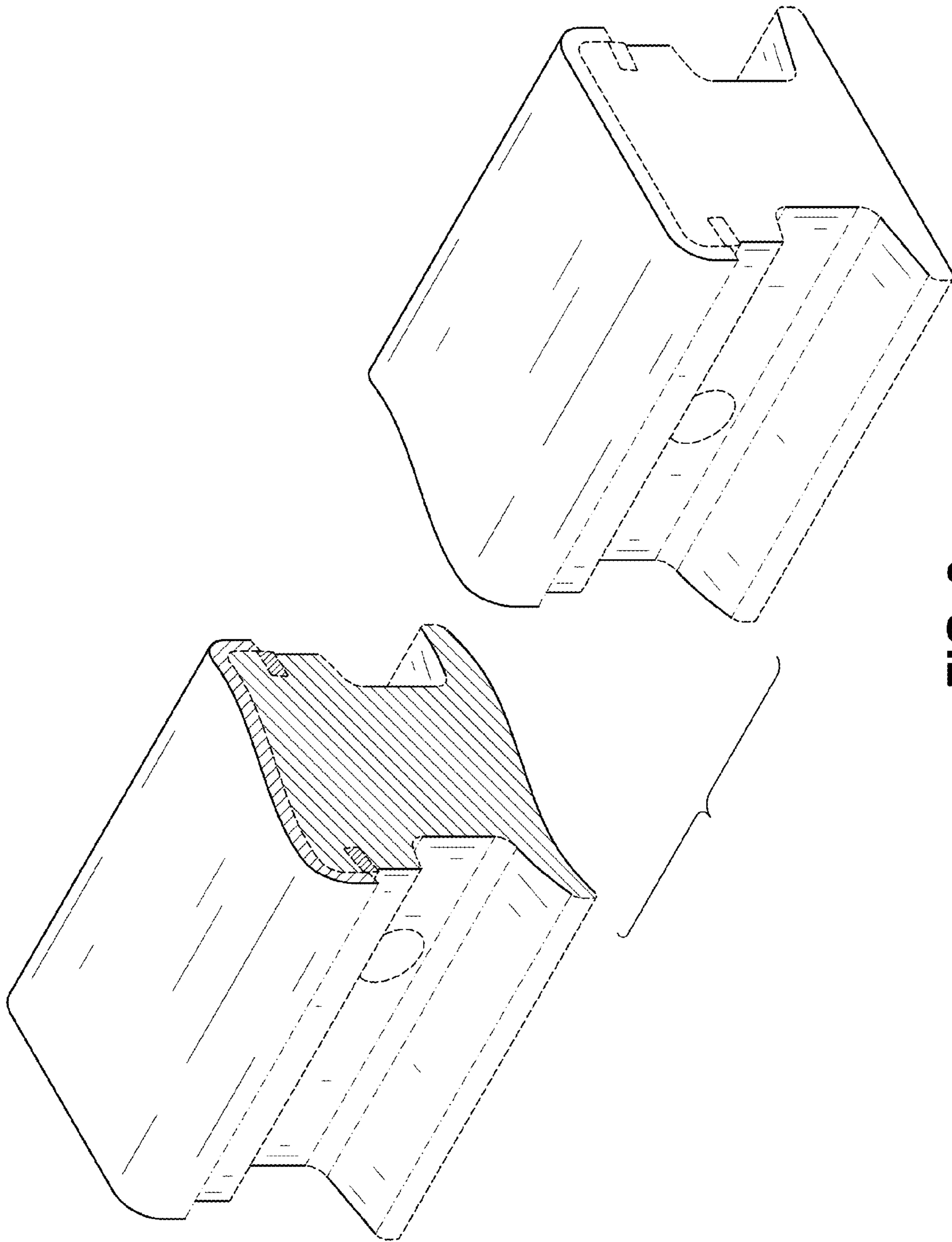

FIG. 3

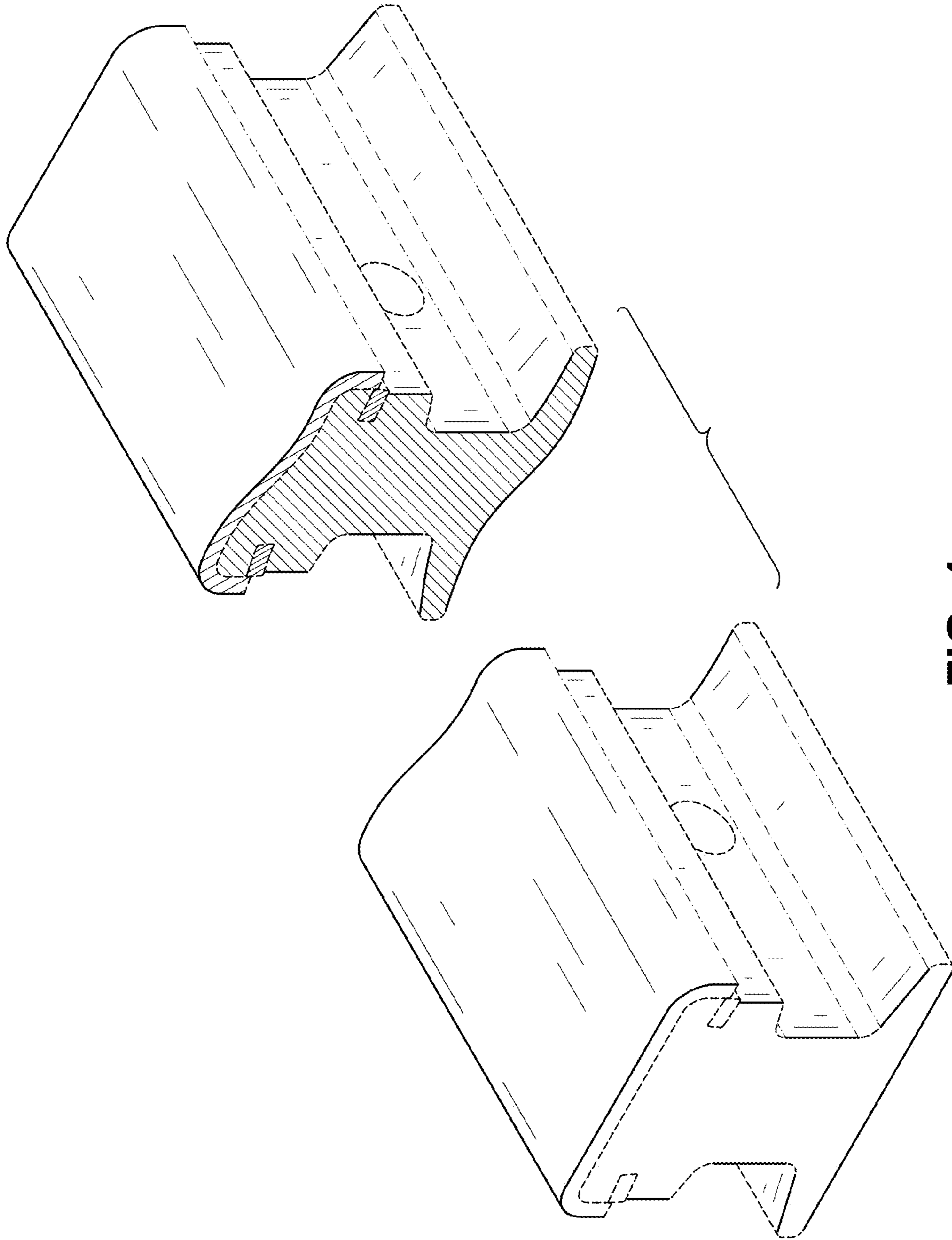

FIG. 4