



US00D893985S

(12) **United States Design Patent** (10) **Patent No.:** **US D893,985 S**
Dankert (45) **Date of Patent:** **** Aug. 25, 2020**

(54) **CARGO HOOK**

(71) Applicant: **Ronald S. Dankert**, Truth or Consequences, NM (US)

(72) Inventor: **Ronald S. Dankert**, Truth or Consequences, NM (US)

(**) Term: **15 Years**

(21) Appl. No.: **29/687,812**

(22) Filed: **Apr. 16, 2019**

(51) **LOC (12) Cl.** **08-05**

(52) **U.S. Cl.**
USPC **D8/367**

(58) **Field of Classification Search**

USPC D08/373, 358, 359, 354, 71, 330, 336, D08/351, 356, 360.1, 363, 364, 367, 370, D08/372, 379, 381, 382, 395, 396; D06/349, 352; D09/426, 502, 750; D10/72, 73, 89; D11/79, 93; D13/103, D13/107; D19/67; D21/673, 674, 675, D21/839, 840; D25/19, 62, 68, 69; D26/40, 49; D29/122, 124; D30/153, D30/155; D12/162; D34/24, 26; D3/10
CPC B65H 75/40; B65H 75/4407; B65H 75/4471; B65H 2701/34; B65H 2701/32; B65H 2511/142; B65H 29/008; B65H 85/66; B65H 85/67; B65H 2701/33; B65H 54/585; B65H 51/22; B65H 75/08; B65H 75/02; B65H 2301/41485; B65H 75/4468; B65H 2301/414323; B65H 2301/414325; B65H 16/02; B65H 2301/4131; B65H 75/403; B65H 75/441; B66D 3/006; B66D 3/18; B66D 3/26; B66D 3/02; B66D 3/14; B63B 21/18; B63B 21/26; B65B 57/005; A61G 7/1051; A61G 7/1061; B66B 11/08; A62C 33/04; B08B 2203/0276; B21C 47/28; H02G 11/02; A01K 89/003; H04M 1/15; A01D 34/822; A47L 9/26; H04R 1/1033; Y10S 24/909; E05C 19/10; E05C 17/50; E05C 3/045; E05C 3/30;

E05C 19/02; E05C 19/026; A47G 25/0614; A47G 25/18; A47G 25/32; A47G 7/047; A47G 7/045; A47G 7/042; A47G 7/044; F16B 12/44; F16B 12/46; F16B 5/0614; F16B 12/02; E04B 1/2612; E04B 2001/2415; E04B 1/5818; E04B 1/5831; A47B 88/0055; E04F 11/1812; F16L 1/0246;

(Continued)

(56) **References Cited**

U.S. PATENT DOCUMENTS

2,636,704 A 4/1953 Norberg
3,974,587 A 8/1976 Levake

(Continued)

OTHER PUBLICATIONS

Pfister BRHMD1C Modern Robe Hook, Polished Chrome, posted May 18, 2017, [retrieved Oct. 15, 2019]. Retrieved from Internet, <URL: <https://www.amazon.ca/Pfister-BRHMD1C-Modern-Polished-Chrome/dp/B07235JYX4> >.*

Primary Examiner — Shannon W Morgan

Assistant Examiner — Kristin E Reed

(74) *Attorney, Agent, or Firm* — Ryan Kromholz & Manion, S.C.

(57) **CLAIM**

I claim the ornamental design for a cargo hook, as shown and described.

DESCRIPTION

FIG. 1 is a front perspective view of a cargo hook; FIG. 2 is a front view of said cargo hook; FIG. 3 is a rear view of said cargo hook; FIG. 4 is a first side view of said cargo hook; FIG. 5 is a second side view of said cargo hook; FIG. 6 is a top view of said cargo hook; and, FIG. 7 is a bottom view of said cargo hook,

1 Claim, 2 Drawing Sheets

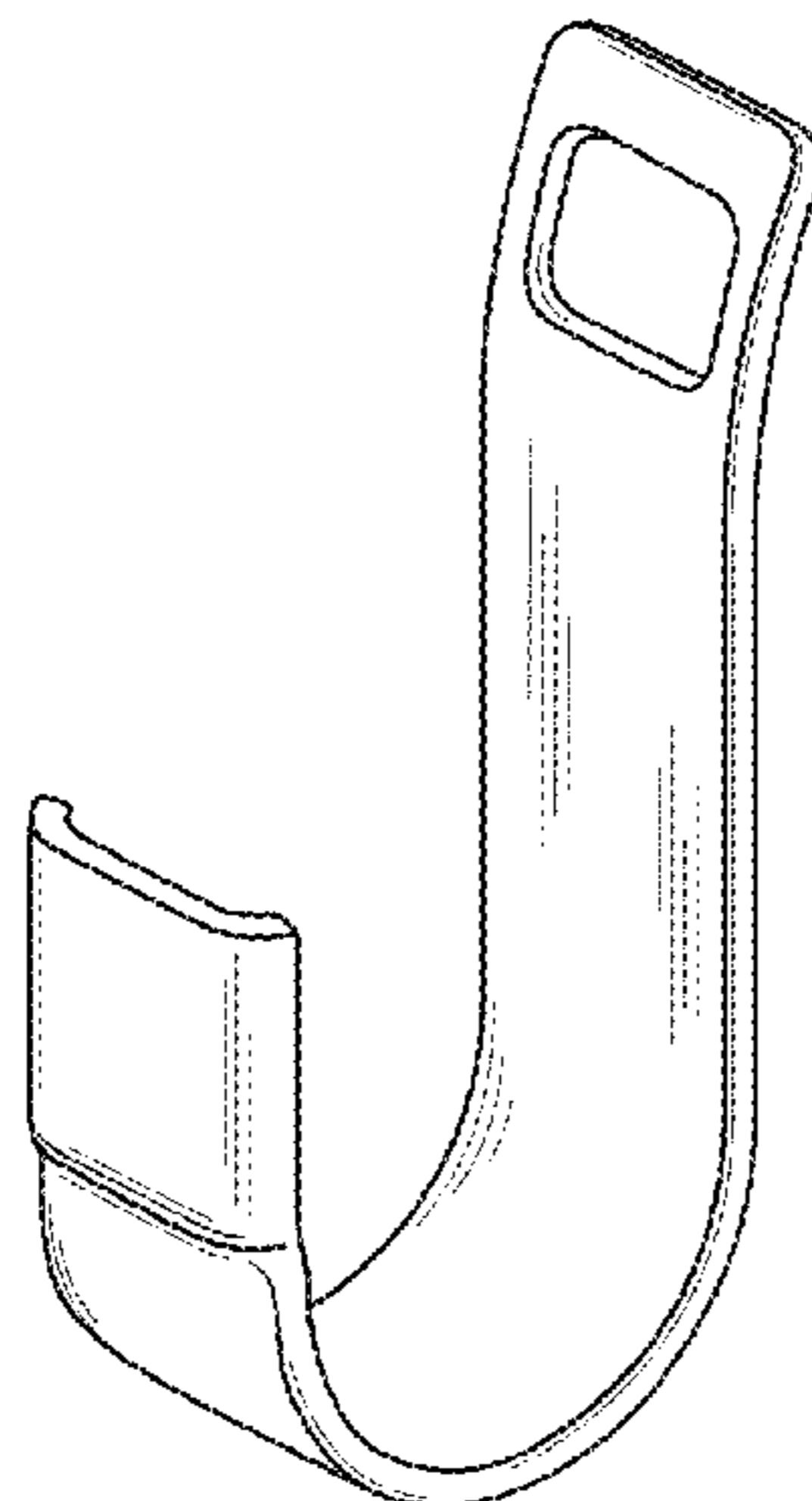

(58) **Field of Classification Search**

CPC A01G 9/024; A01G 25/14; A01G 27/001;
 A01G 9/042; A01G 27/005; A01G
 31/001; A01G 9/02; A01G 9/083; A01G
 9/12; B60D 1/185; B60P 7/083; B60P
 7/0853; B60P 7/0823; Y10T 24/2175;
 Y10T 24/2164

See application file for complete search history.

(56) **References Cited**

U.S. PATENT DOCUMENTS

D258,138 S 2/1981 Wood
 D276,978 S * 1/1985 Fee D8/382
 4,779,293 A 10/1988 Dabney
 4,891,853 A 1/1990 Dabney
 4,932,535 A 6/1990 Dabney
 D353,992 S * 1/1995 Dombrowski D8/373
 D360,355 S * 7/1995 Adams D8/367
 5,497,979 A 3/1996 Schulz, Jr.
 D374,604 S 10/1996 Hnatowicz
 D387,637 S 12/1997 Salgy
 D395,390 S * 6/1998 Etherton D8/367
 D423,916 S 5/2000 Kalat
 D434,310 S 11/2000 Kalat
 D465,724 S * 11/2002 Goodman D8/367
 D465,997 S 11/2002 Kalat
 D466,791 S 12/2002 Kelleghan
 D474,105 S 5/2003 Lee
 D478,499 S * 8/2003 Winig D8/367
 D482,269 S 11/2003 Martello
 D492,188 S 6/2004 Goldberg
 D493,092 S 7/2004 Kalat

7,025,545 B1 4/2006 Robison
 7,100,902 B1 9/2006 Lu
 D540,943 S * 4/2007 Edwards D24/128
 7,353,910 B2 4/2008 Klingler
 D600,101 S 9/2009 Meyers
 D605,497 S * 12/2009 Lulla D8/354
 D639,937 S 6/2011 Gray
 D661,978 S 6/2012 Holechek
 D700,830 S 3/2014 Brockman
 D706,617 S 6/2014 Hendricks
 D712,240 S 9/2014 Bracegirdle
 D721,570 S 1/2015 Caughron
 8,974,158 B1 3/2015 Hatch
 8,985,664 B2 3/2015 Bermes
 D745,378 S 12/2015 Kusmirek
 D755,612 S 5/2016 Cooper
 D765,498 S 9/2016 Dankert
 D767,998 S 10/2016 Peacock
 D791,583 S * 7/2017 Griffin D8/373
 9,725,028 B1 8/2017 Etkorn
 9,827,896 B1 11/2017 Dankert
 9,849,822 B1 12/2017 Dankert
 D870,539 S * 12/2019 Lu D8/373
 2005/0286986 A1 12/2005 Thomson
 2006/0177282 A1 8/2006 Blosser
 2009/0031508 A1 * 2/2009 van der Meijden .. E04H 4/1663
 15/1.7
 2009/0041557 A1 2/2009 Lin
 2013/0001967 A1 1/2013 Root
 2013/0322981 A1 12/2013 Root
 2014/0255120 A1 9/2014 Simmons
 2018/0132610 A1 * 5/2018 Lu A47B 57/42
 2018/0132611 A1 * 5/2018 Lu A47B 61/003
 2018/0135796 A1 * 5/2018 Lu A47F 5/103

* cited by examiner

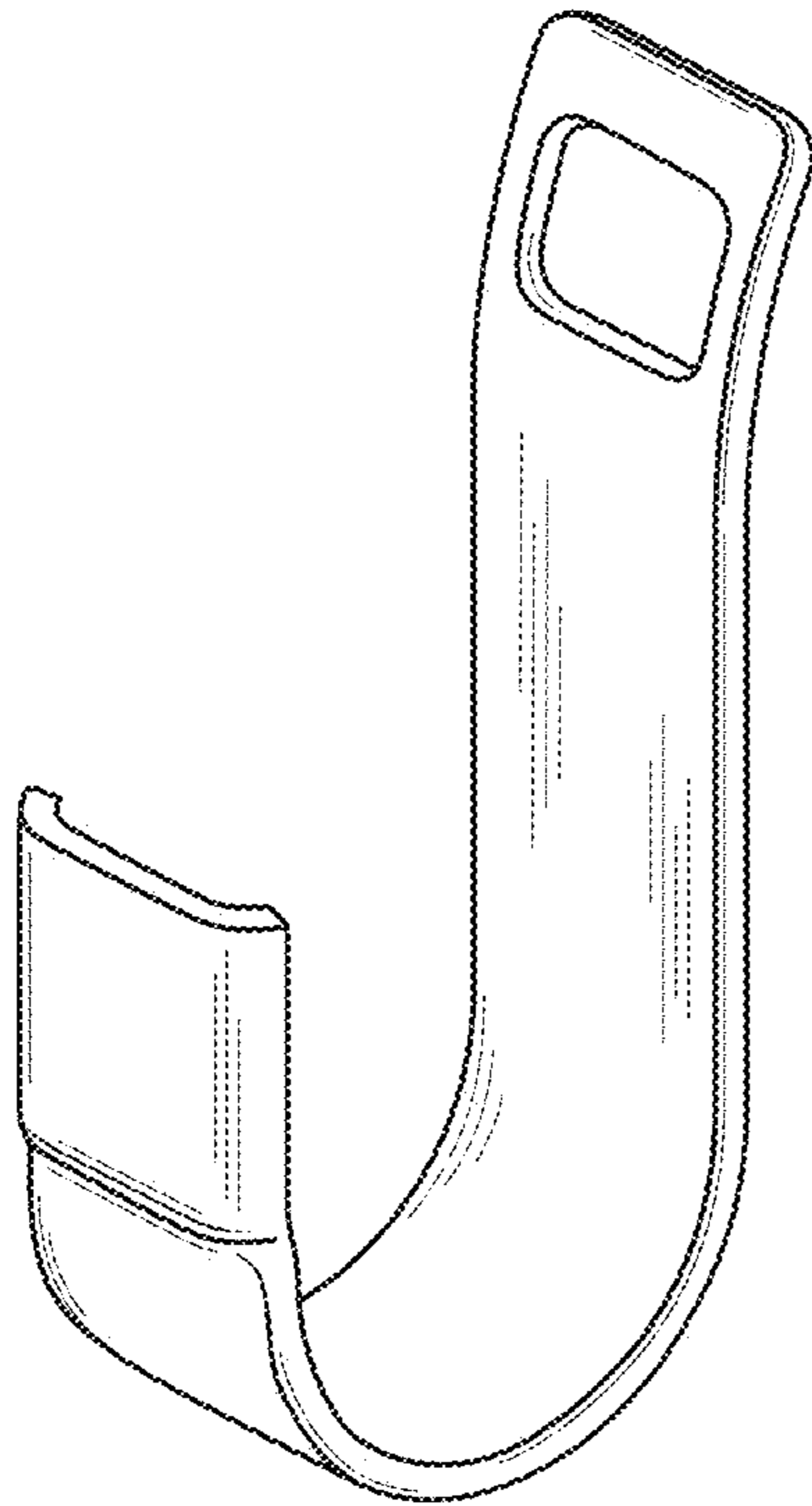

Fig. 1

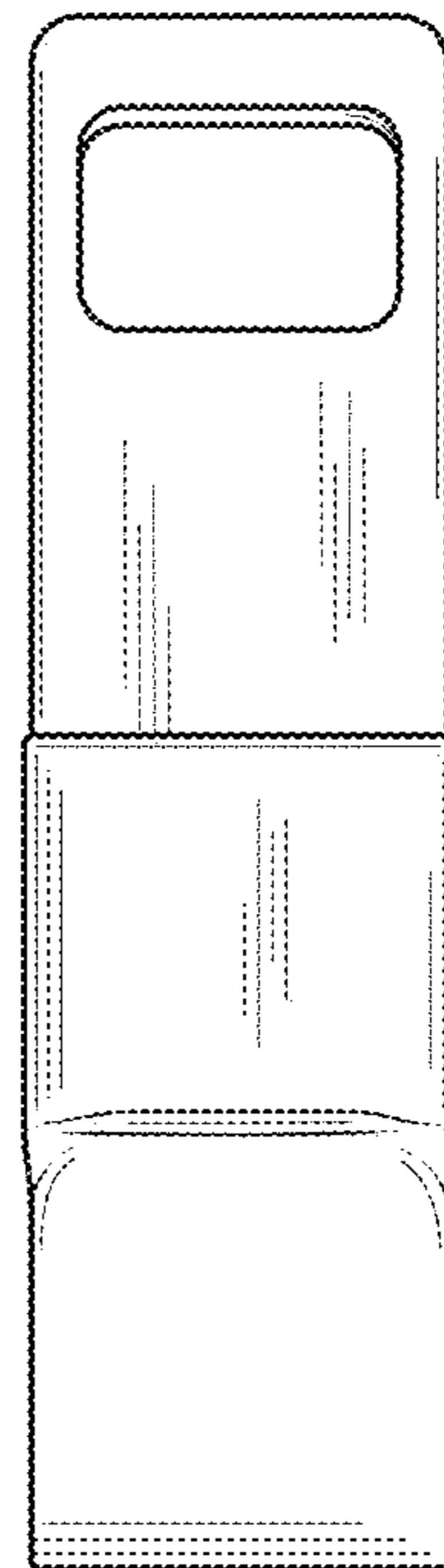
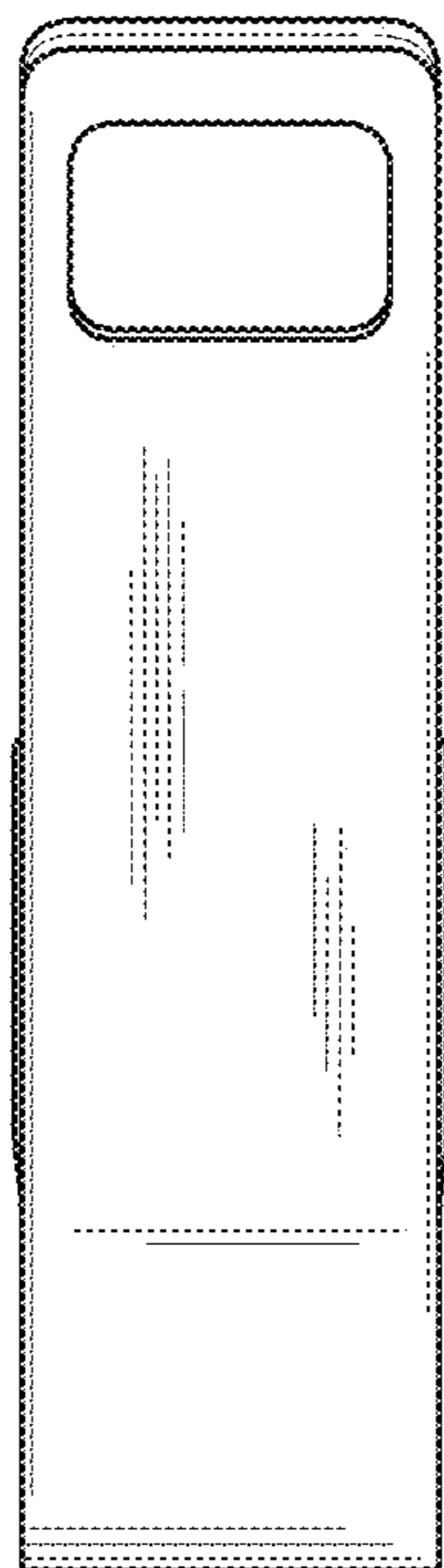

Fig. 2

Fig. 3



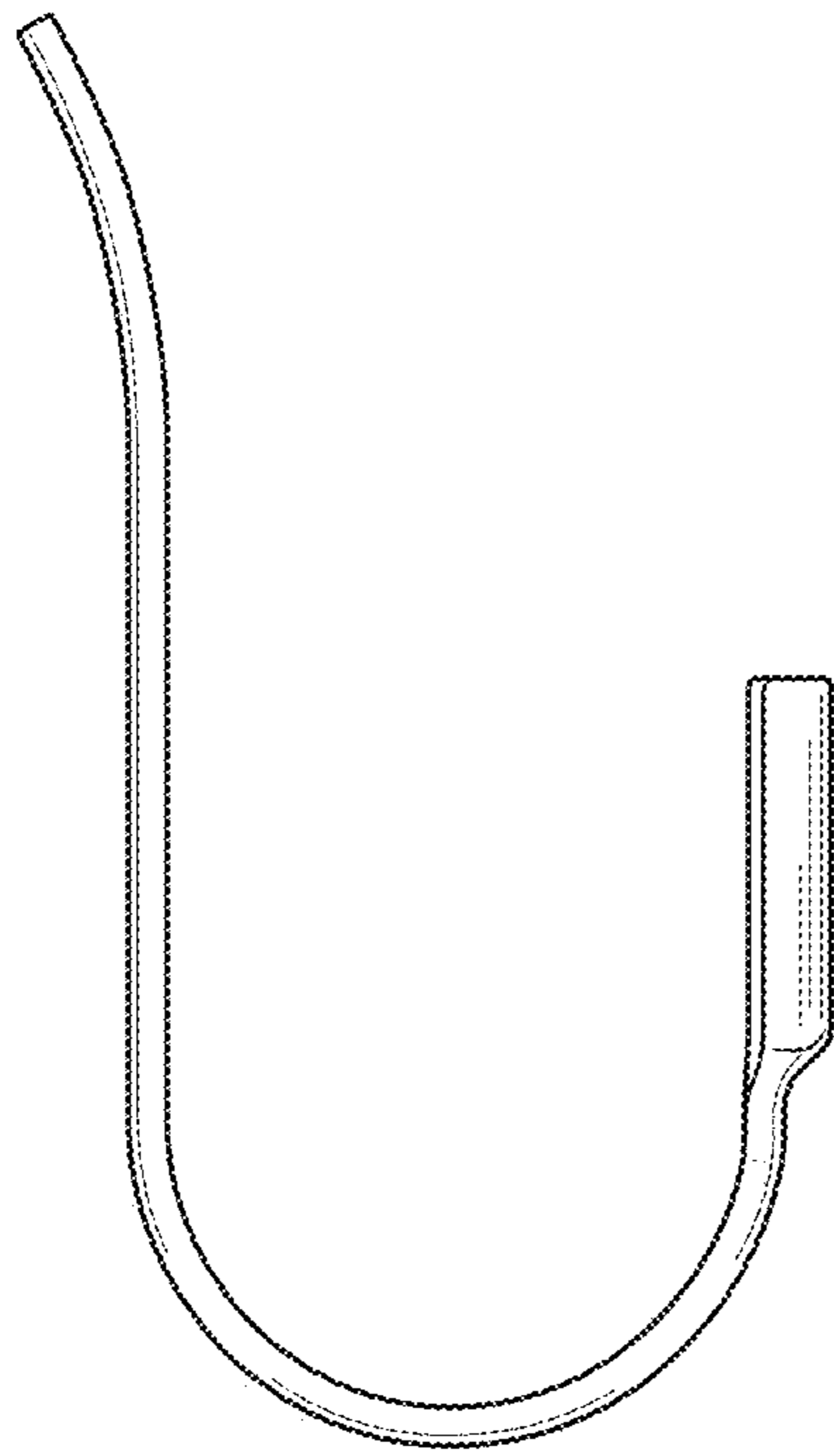

Fig. 4

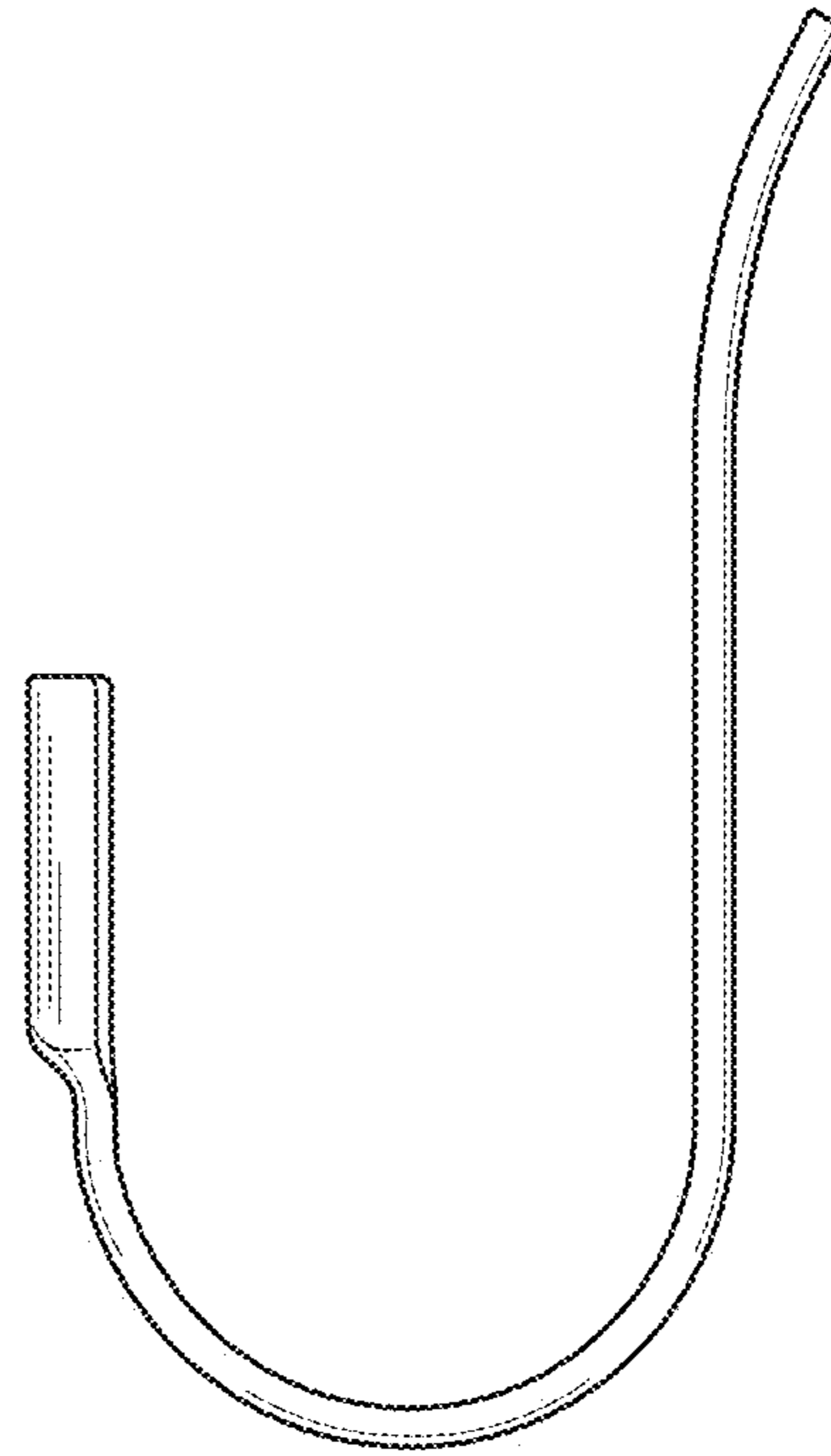

Fig. 5

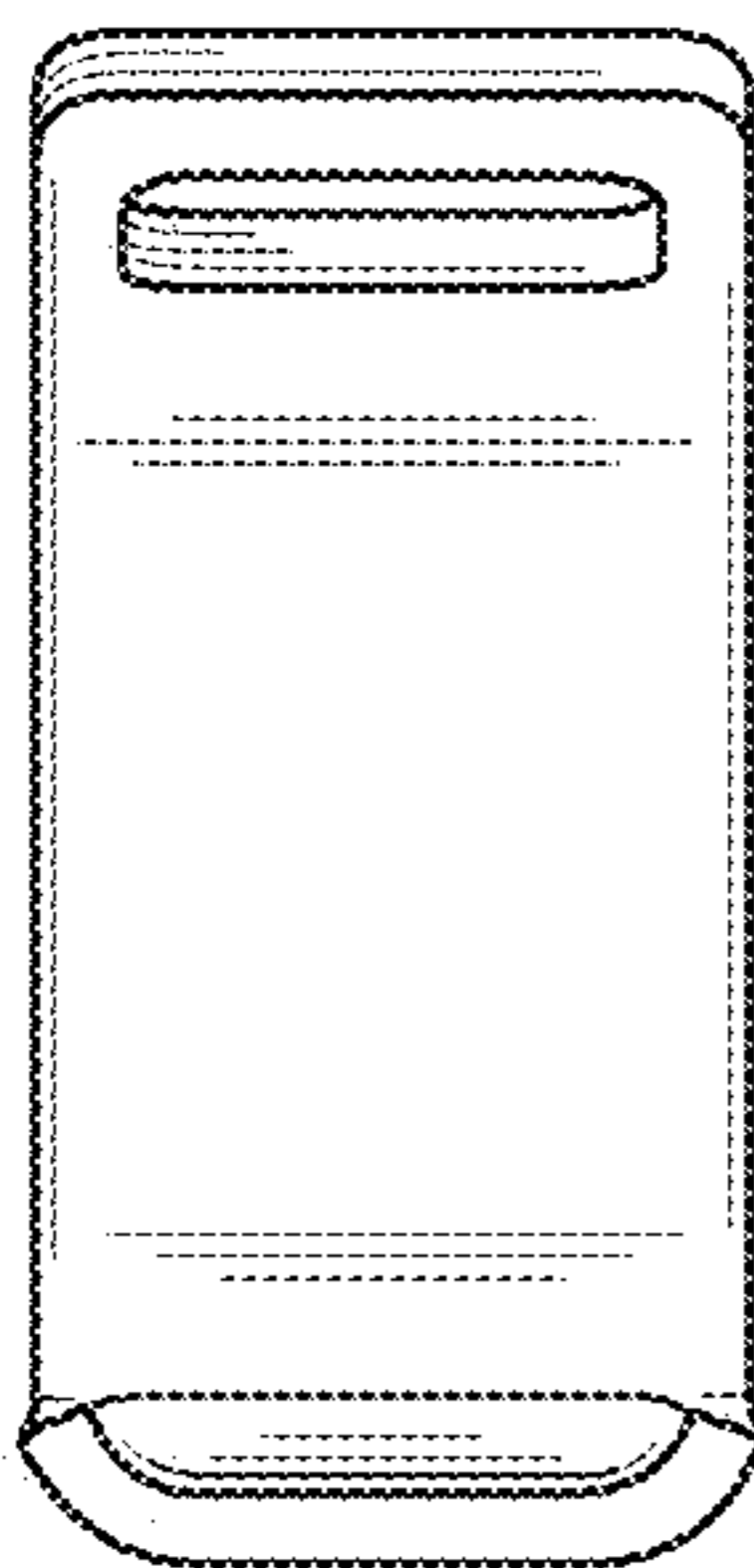

Fig. 6

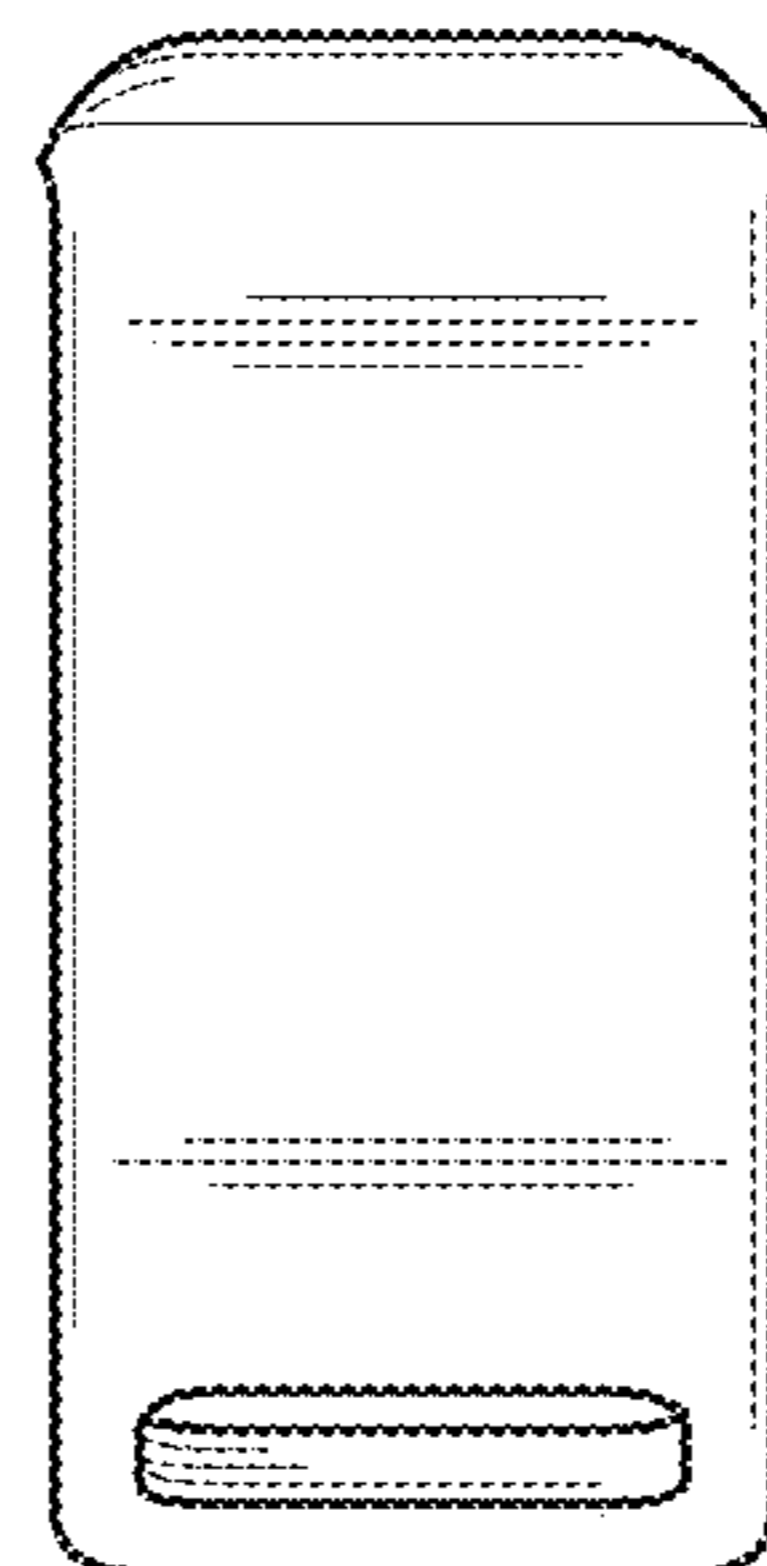

Fig. 7