

US00D893859S

(12) **United States Design Patent** (10) **Patent No.:** **US D893,859 S**  
**Tatsumi** (45) **Date of Patent:** **\*\* Aug. 25, 2020**

(54) **CASE FOR WIND INSTRUMENT**  
(71) Applicant: **YAMAHA CORPORATION**,  
Hamamatsu-shi (JP)  
(72) Inventor: **Keizo Tatsumi**, Hamamatsu (JP)  
(73) Assignee: **YAMAHA CORPORATION**,  
Hamamatsu-shi, Shizuoka (JP)  
(\*\*) Term: **15 Years**  
(21) Appl. No.: **29/610,840**  
(22) Filed: **Jul. 17, 2017**  
(30) **Foreign Application Priority Data**  
Jan. 18, 2017 (JP) ..... 2017-000693  
(51) **LOC (12) Cl.** ..... **03-01**  
(52) **U.S. Cl.**  
USPC ..... **D3/204**  
(58) **Field of Classification Search**  
USPC ..... D3/201, 204, 273, 269, 276, 294;  
D10/10, 13  
CPC ..... G10G 7/005  
See application file for complete search history.

D793,730 S \* 8/2017 Zheng ..... D3/204  
D795,567 S \* 8/2017 Goetz ..... D3/204  
D799,202 S \* 10/2017 Rolfs ..... D3/203.1  
2010/0270187 A1 \* 10/2010 Sonoda ..... G10G 7/005  
206/314

**FOREIGN PATENT DOCUMENTS**

CN 303941651 \* 11/2016  
CN 303941654 \* 11/2016  
EM 004106433-0001 \* 7/2017

**OTHER PUBLICATIONS**

Nouveau Yamaha Venova YVS-100, posted at youtube.com. posted  
May 13, 2017, online, URL: <https://www.youtube.com/watch?v=TSXJgzjipAY> (Year: 2017).\*

\* cited by examiner

*Primary Examiner* — Lilyana Bekic  
*Assistant Examiner* — Mary Shannon Malley  
(74) *Attorney, Agent, or Firm* — Sughrue Mion, PLLC

(57) **CLAIM**

The ornamental design for a case for wind instrument, as  
shown and described.

**DESCRIPTION**

FIG. 1 is a perspective view of the front, bottom and right  
side of a case for wind instrument showing my new design;  
FIG. 2 is a front view thereof;  
FIG. 3 is a rear view thereof;  
FIG. 4 is a left side view thereof;  
FIG. 5 is a right side view thereof;  
FIG. 6 is a top plan view thereof; and,  
FIG. 7 is a bottom view thereof.  
The broken lines show portions of the case for wind instru-  
ment that form no part of the claimed design.

**1 Claim, 4 Drawing Sheets**

(56) **References Cited**  
**U.S. PATENT DOCUMENTS**  
D42,984 S \* 9/1912 Theiss ..... D3/204  
D205,723 S \* 9/1966 Cohen et al. .... D3/204  
D225,033 S \* 10/1972 Hyman ..... D3/204  
D280,359 S \* 9/1985 Bohunsky ..... D3/204  
D380,292 S \* 7/1997 Funk ..... D3/204  
D482,518 S \* 11/2003 Nakajima ..... D3/201  
D489,527 S \* 5/2004 Izen ..... D3/204  
D609,455 S \* 2/2010 Coppiardi ..... D3/204  
D746,047 S \* 12/2015 Hungate ..... D3/204

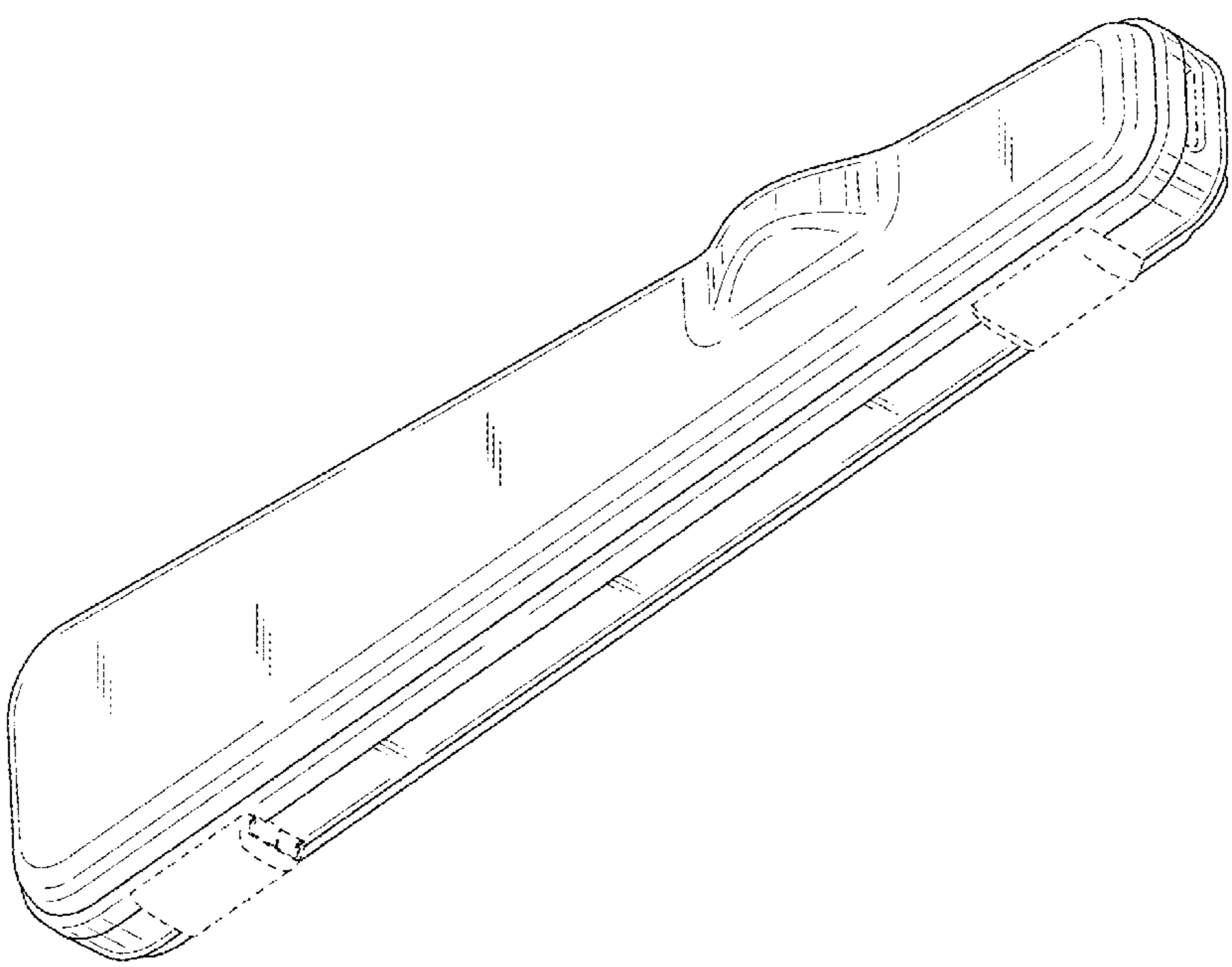

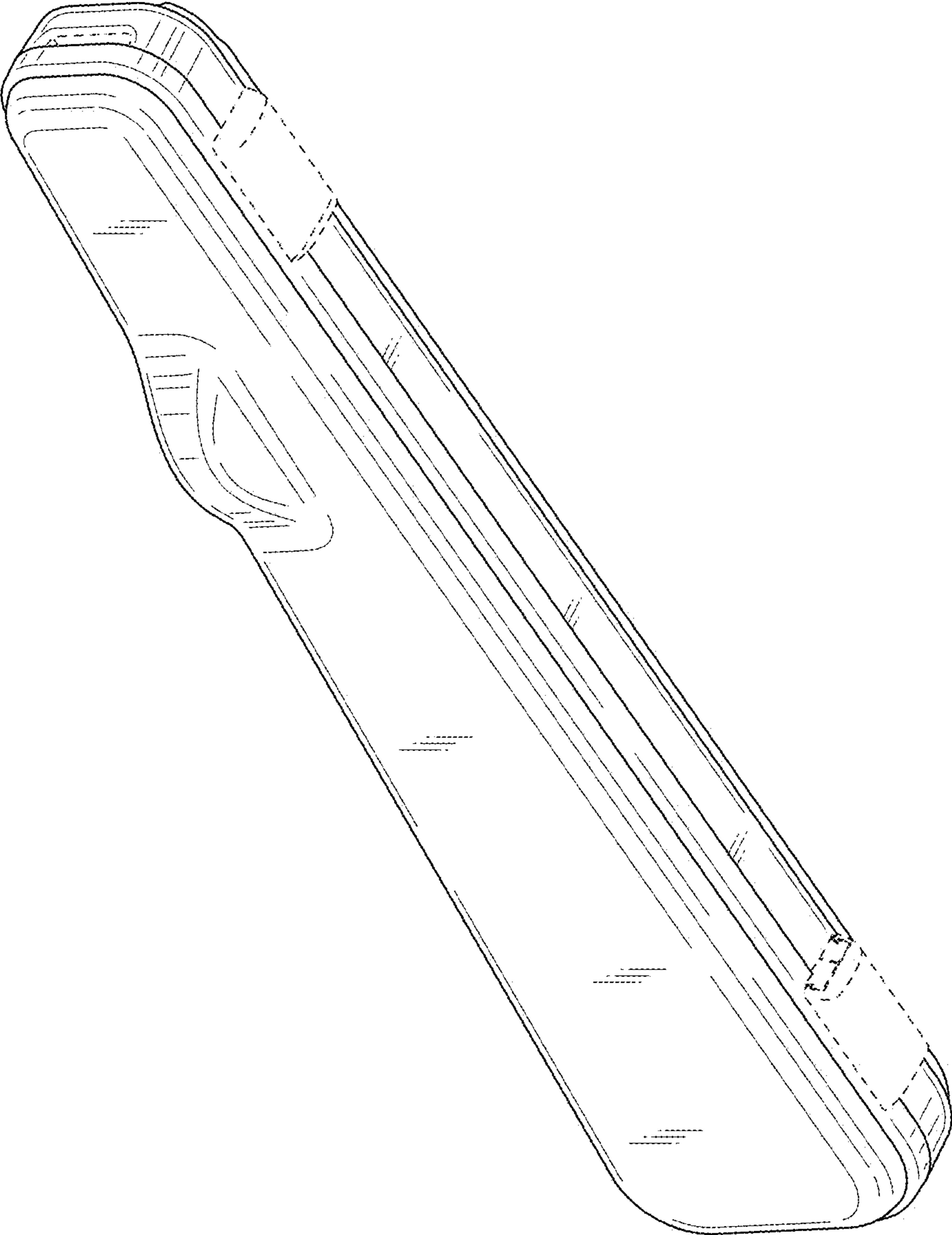

Fig. 1

Fig. 2

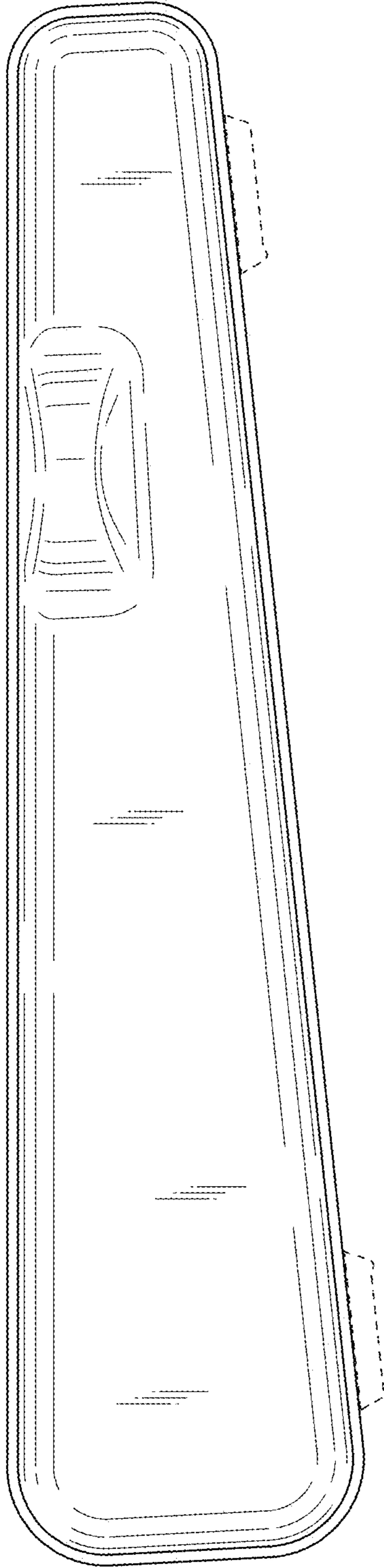

Fig. 3

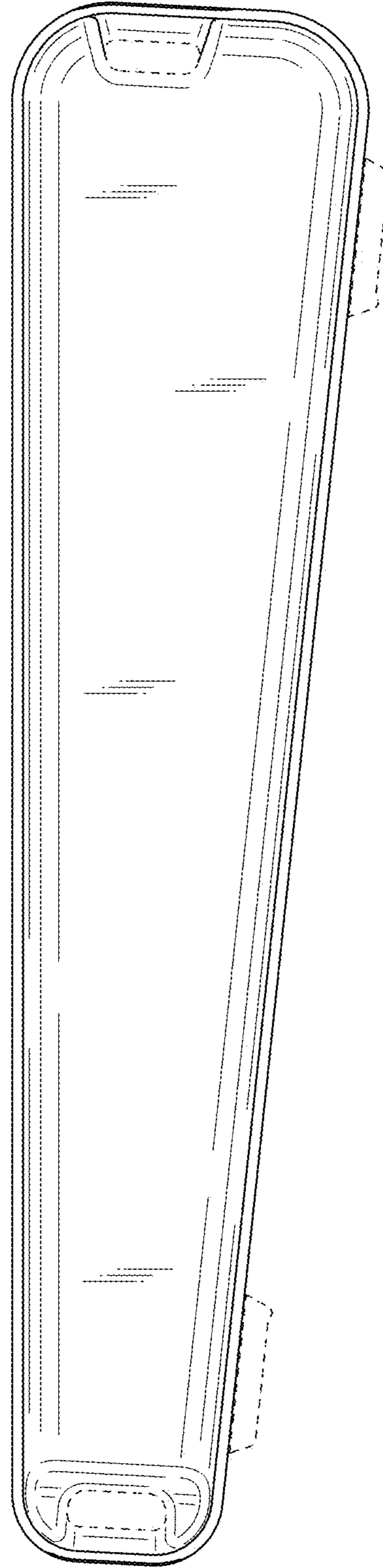

Fig. 5

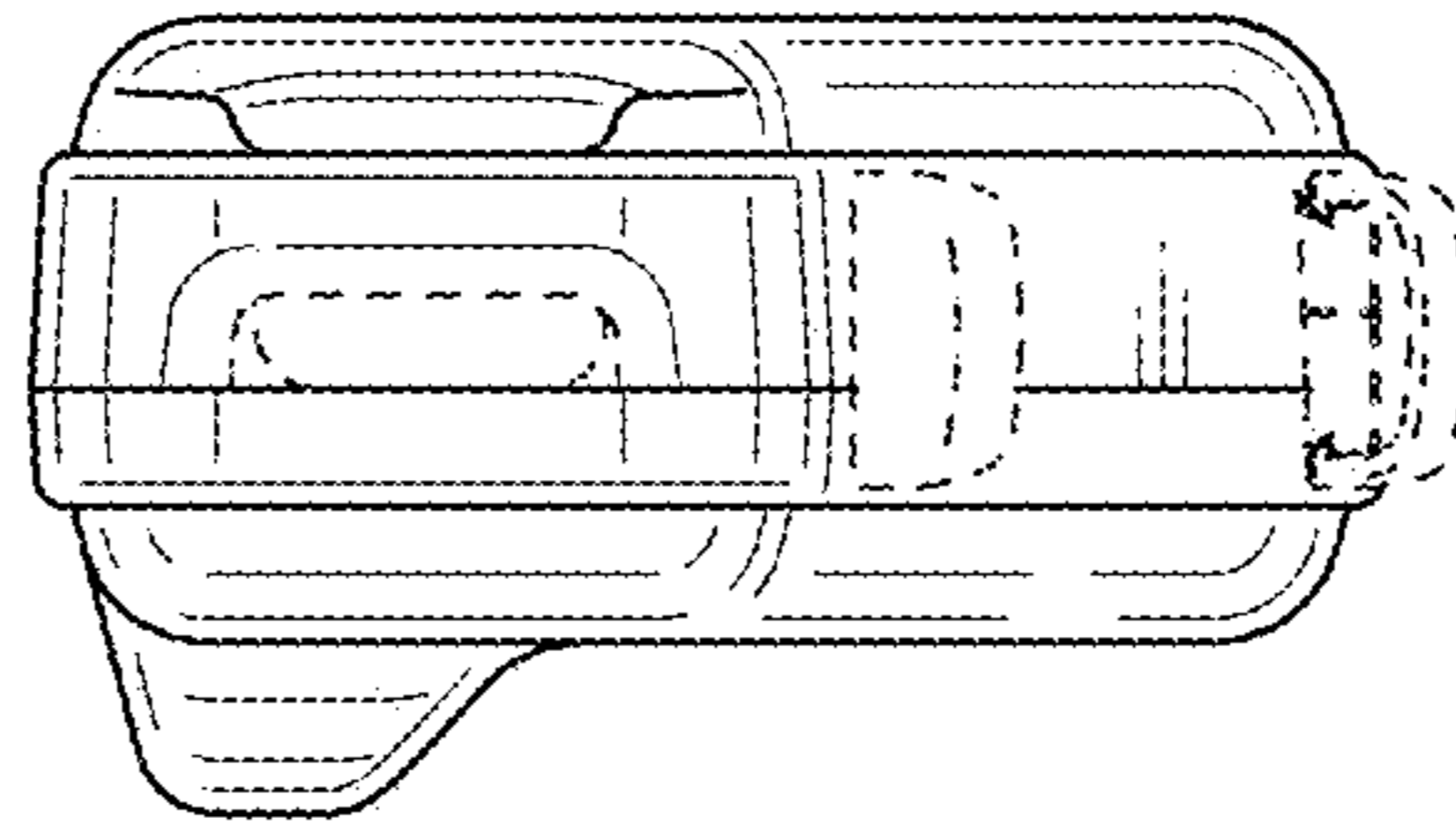

Fig. 4

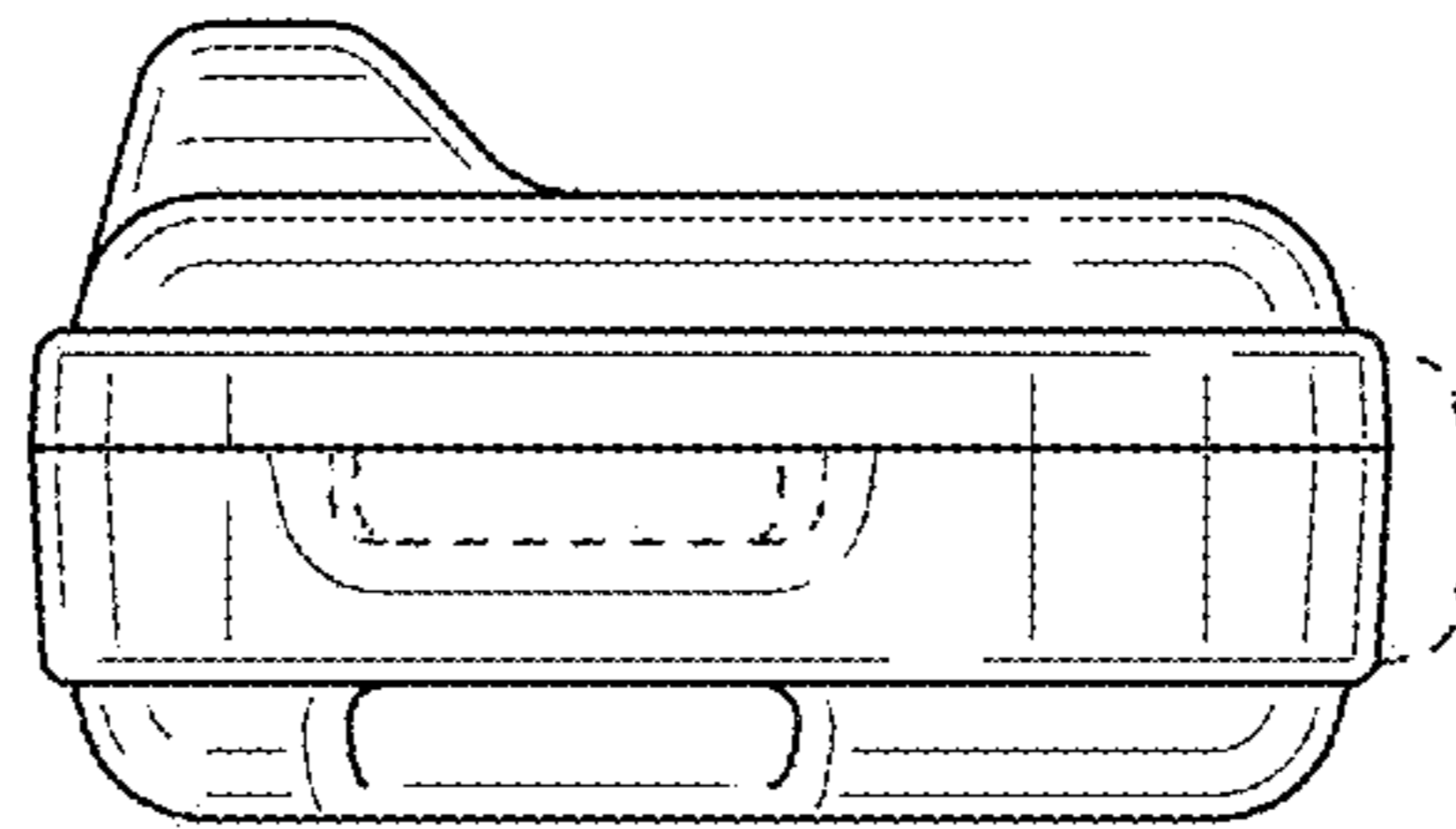



Fig. 6

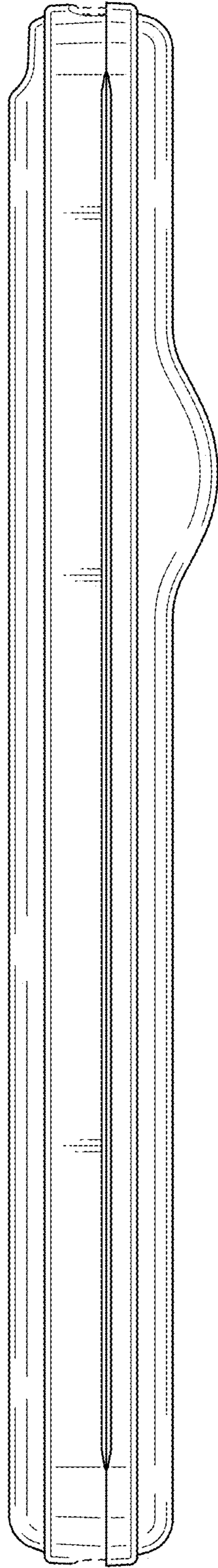

Fig. 7

