



US00D893776S

(12) **United States Design Patent**
Lin

(10) **Patent No.:** **US D893,776 S**

(45) **Date of Patent:** **** Aug. 18, 2020**

(54) **AUTOMOBILE HEADLIGHT**

(71) Applicant: **Chi-Chung Lin**, Hsinchu (TW)

(72) Inventor: **Chi-Chung Lin**, Hsinchu (TW)

(**) Term: **15 Years**

(21) Appl. No.: **29/691,558**

(22) Filed: **May 17, 2019**

(51) **LOC (12) Cl.** **26-06**

(52) **U.S. Cl.**
USPC **D26/28**

(58) **Field of Classification Search**
USPC D26/28, 29, 30, 31, 32, 33, 34, 35, 36
CPC F21S 48/00; F21S 48/10; F21S 48/115;
F21S 48/225; F21S 48/1233; F21S
48/1266; F21S 48/1388; F21S 48/2268;
F21V 21/04; F21W 2103/35; F21W 3/40;
F21W 2102/17; F21W 2102/30; F21W
2103/00; F21W 2103/55; F21W 2104/00;
F21W 2107/17; F21W 2107/13
See application file for complete search history.

(56) **References Cited**

U.S. PATENT DOCUMENTS

D566,307 S * 4/2008 Hsu D26/28
D567,970 S * 4/2008 Hsu D26/28

D582,072 S * 12/2008 Yang D26/28
D737,484 S * 8/2015 Lai D26/28
D744,677 S * 12/2015 Lai D26/28
D747,515 S 1/2016 McMahan et al.
D776,310 S 1/2017 Mackay
D831,245 S * 10/2018 Lin D26/28
D831,246 S * 10/2018 Yang D26/28
D841,207 S * 2/2019 Yang D26/28
D853,000 S * 7/2019 Lin D26/28

* cited by examiner

Primary Examiner — Angela J Lee

(74) *Attorney, Agent, or Firm* — Alexander Chen, Esq.

(57) **CLAIM**

The ornamental design for an automobile headlight, as shown and described.

DESCRIPTION

FIG. 1 is a perspective view of an automobile headlight; FIG. 2 is a front view thereof; and, FIG. 3 is a side view thereof.

The broken lines are included to show environmental structure and form no part of the claimed design. The drawings and descriptions represent the left side embodiment. The claim is also for a mirror image right side embodiment.

1 Claim, 3 Drawing Sheets

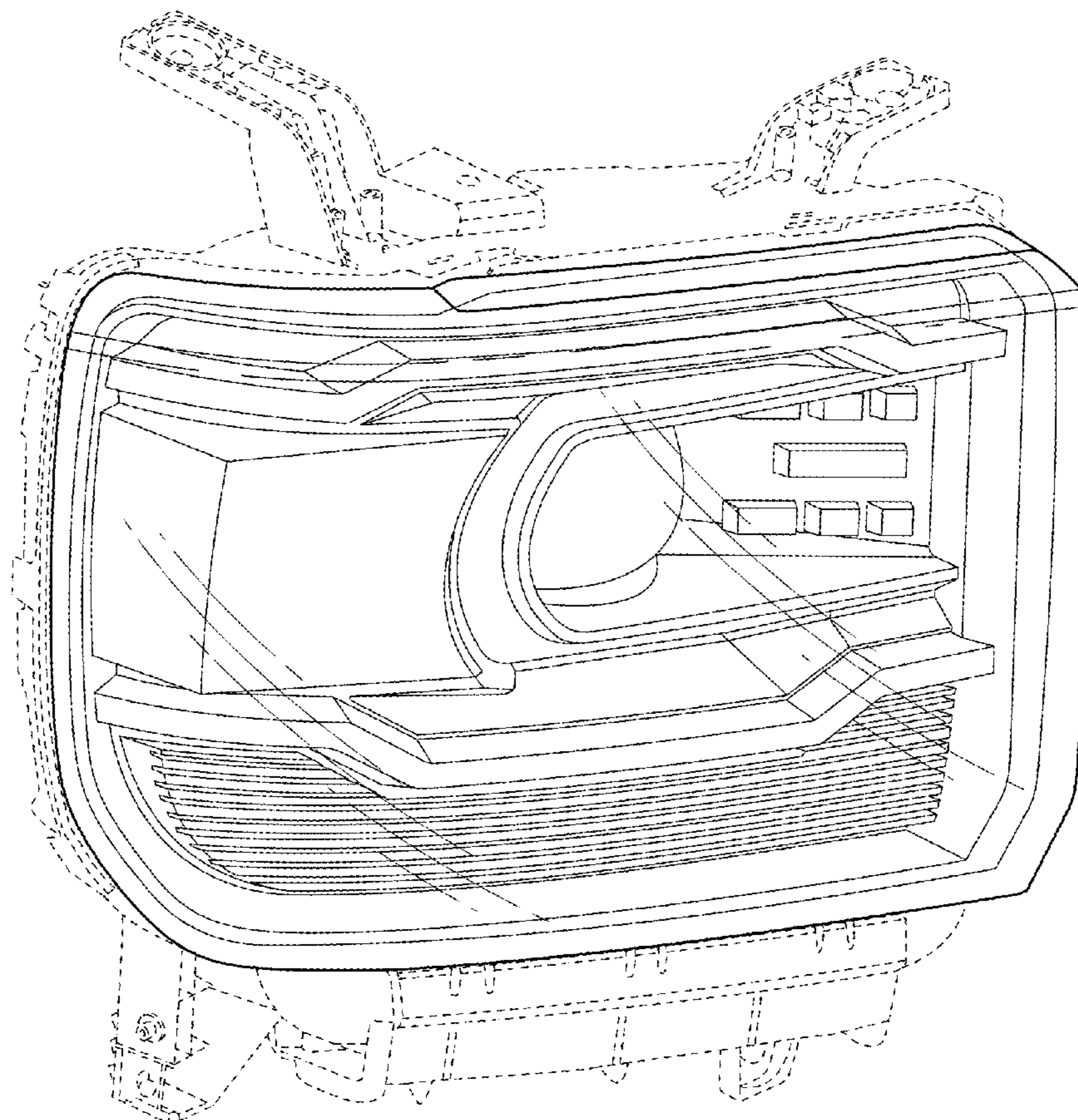

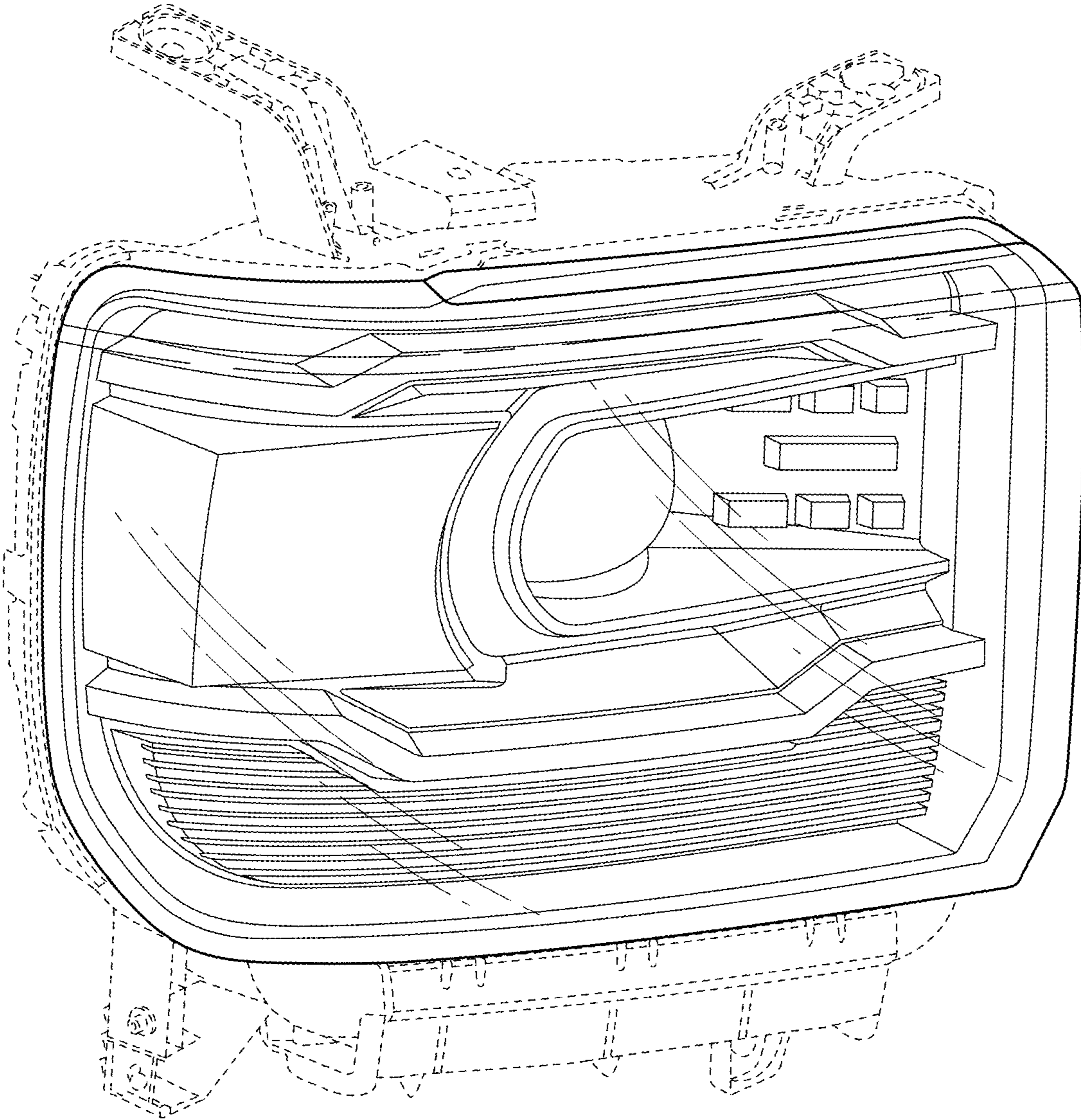

FIG. 1

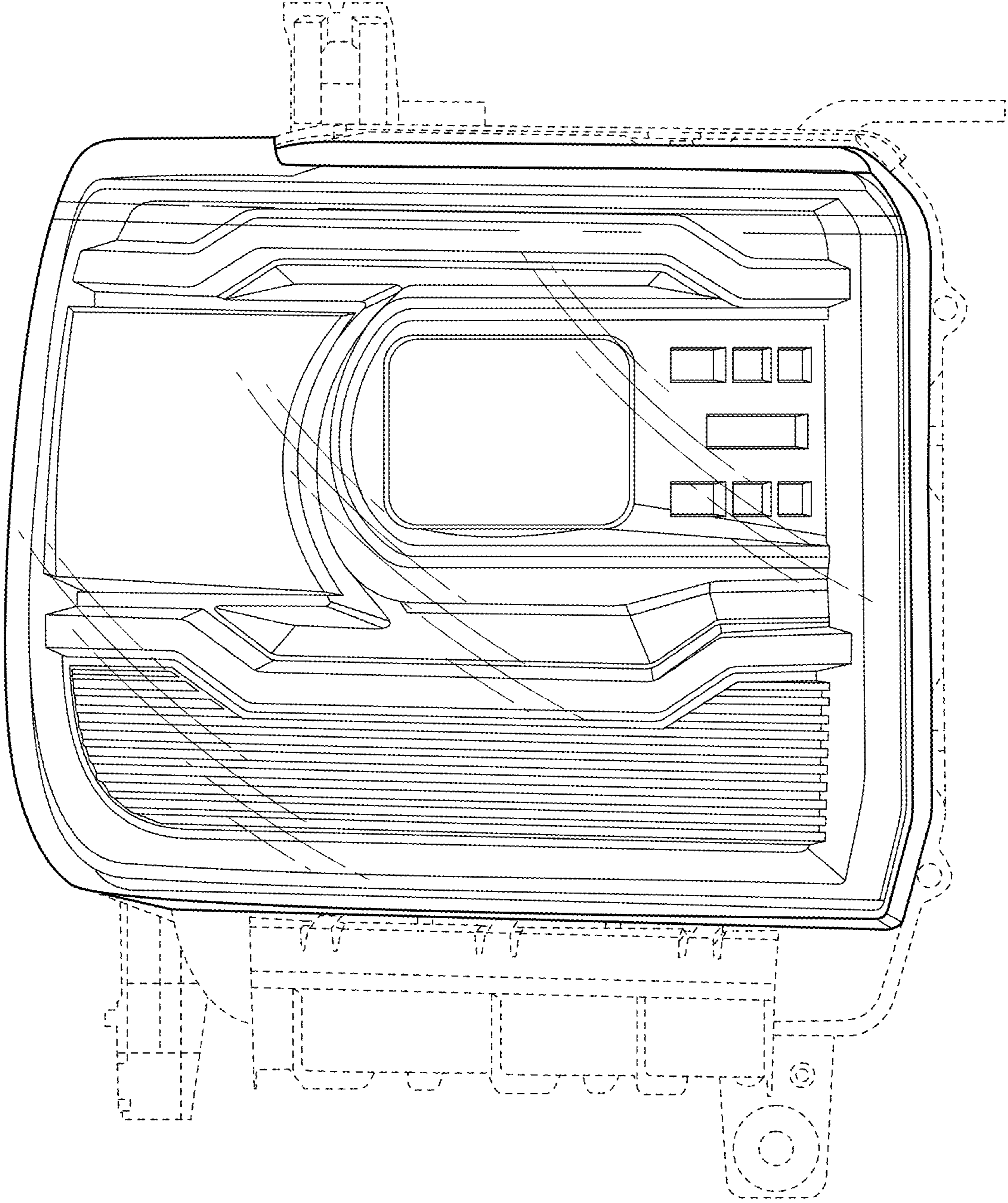

FIG. 2

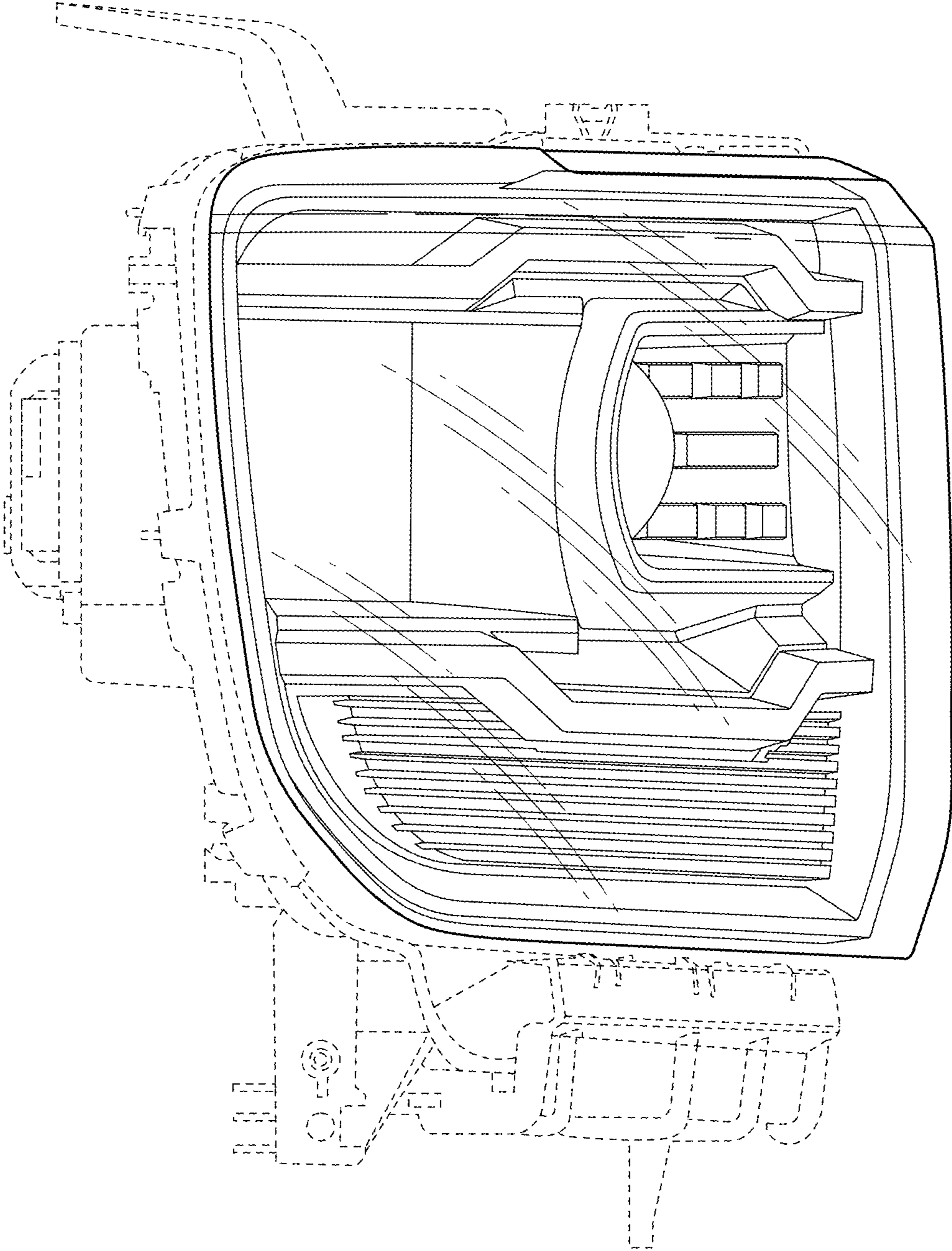

FIG. 3