



US00D893551S

(12) **United States Design Patent** (10) **Patent No.:** **US D893,551 S**
Wei (45) **Date of Patent:** **** Aug. 18, 2020**

(54) **INTAKE MANIFOLD**

FOREIGN PATENT DOCUMENTS

(71) Applicant: **DeepMotor, Inc.**, Rancho Cucamonga, CA (US)

CN 303479863 12/2015
CN 303727690 6/2016

(72) Inventor: **Yong Wei**, Rancho Cucamonga, CA (US)

OTHER PUBLICATIONS

(73) Assignee: **DEEPMOTOR, INC.**, Rancho Cucamong, CA (US)

GT-R Billet Intake Manifold for 08+ 3.8L V6 GTR R35 VR38DETT VR38 3.8 Twin TURBO https://www.amazon.com/Billet-Intake-Manifold-VR38DETT-TURBO/dp/B082XHN4TK/ref=sr_1_1?keywords=billet+VR38+intake+manifold+for+GTR+R35&gid=1582842469&s=automotive&sr=1-1 (Year: 2019).*

(**) Term: **15 Years**

(21) Appl. No.: **29/691,756**

Primary Examiner — T Chase Nelson

(22) Filed: **May 19, 2019**

Assistant Examiner — Ania Aman

(51) **LOC (12) Cl.** **15-01**

(74) *Attorney, Agent, or Firm* — Loza & Loza, LLP; Heidi L. Eisenhut

(52) **U.S. Cl.**

USPC **D15/5**

(57) **CLAIM**

(58) **Field of Classification Search**

USPC D15/1-5

CPC F02M 35/10091; F02M 35/10222; F02M 35/10295; F02M 35/10321; F02M 35/10262; F02M 35/104; F02M 35/10354; F02M 35/116; F02M 35/10052; F02M 35/10078; F02M 35/112; F02M 35/10085; F02M 31/00; F02M 31/04; F02M 31/042; F02M 31/045; F02M 31/047; F02M 31/093; F02M 35/10144; F02M 35/10039; F02M 35/10347; F02M 35/10334

The ornamental design for an intake manifold, as shown and described.

See application file for complete search history.

DESCRIPTION

(56) **References Cited**

U.S. PATENT DOCUMENTS

4,957,071 A * 9/1990 Matsuo F02M 35/116 123/184.36

D364,628 S 11/1995 Haller

5,494,011 A 2/1996 Haller

6,581,561 B1 * 6/2003 Brodesser F02M 35/10085 123/184.34

D654,094 S 2/2012 Dralle

8,122,864 B2 2/2012 Randall et al.

(Continued)

FIG. 1 is a front, right, top perspective view of an intake manifold;
FIG. 2 is a rear, left, bottom perspective view of the intake manifold of FIG. 1;
FIG. 3 is a right side elevation view of the intake manifold of FIG. 1;
FIG. 4 is a left side elevation view of the intake manifold of FIG. 1;
FIG. 5 is a front elevation view of the intake manifold of FIG. 1;
FIG. 6 is a rear elevation view of the intake manifold of FIG. 1;
FIG. 7 is a top plan view of the intake manifold of FIG. 1; and,
FIG. 8 is a bottom plan view of the intake manifold of FIG. 1.

The broken lines show features of the intake manifold that form no part of the claimed design.

1 Claim, 8 Drawing Sheets

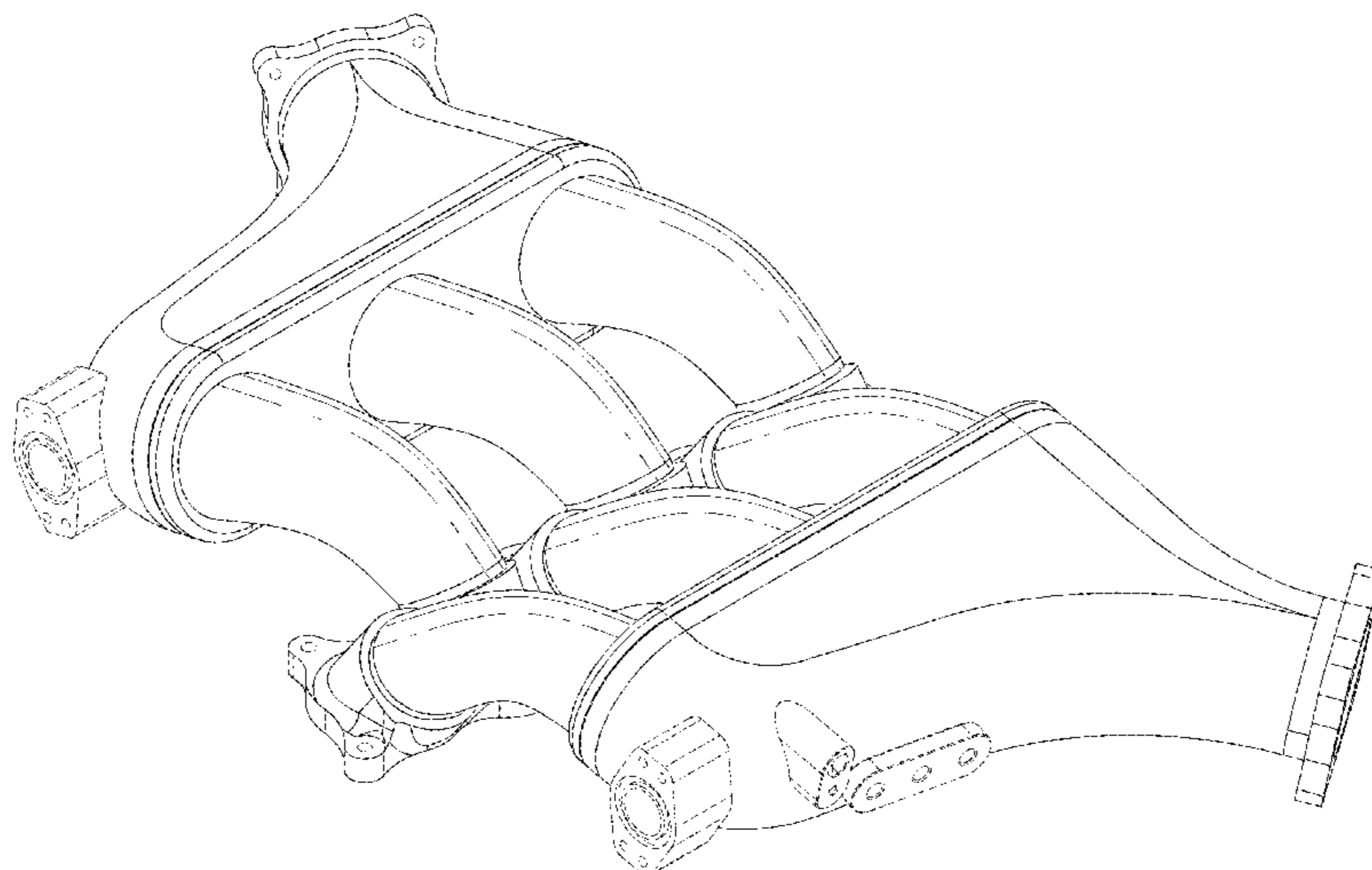

(56)

References Cited

U.S. PATENT DOCUMENTS

8,220,430	B2	7/2012	Gupta	
D673,979	S	1/2013	Finnican	
D677,699	S	3/2013	Finnican	
D680,132	S	4/2013	Finnican	
D737,862	S	9/2015	Finnican	
9,273,653	B2	3/2016	Wilson	
9,617,957	B2	4/2017	Shinkai et al.	
D802,628	S	11/2017	Fischetto	
D814,523	S	4/2018	Vaninetti et al.	
2009/0101100	A1*	4/2009	Ichikawa B60T 17/04 123/184.53
2009/0272589	A1*	11/2009	Ballard F02M 35/116 180/68.3
2017/0067421	A1*	3/2017	Hamzeh F02M 35/104

* cited by examiner

FIG. 1

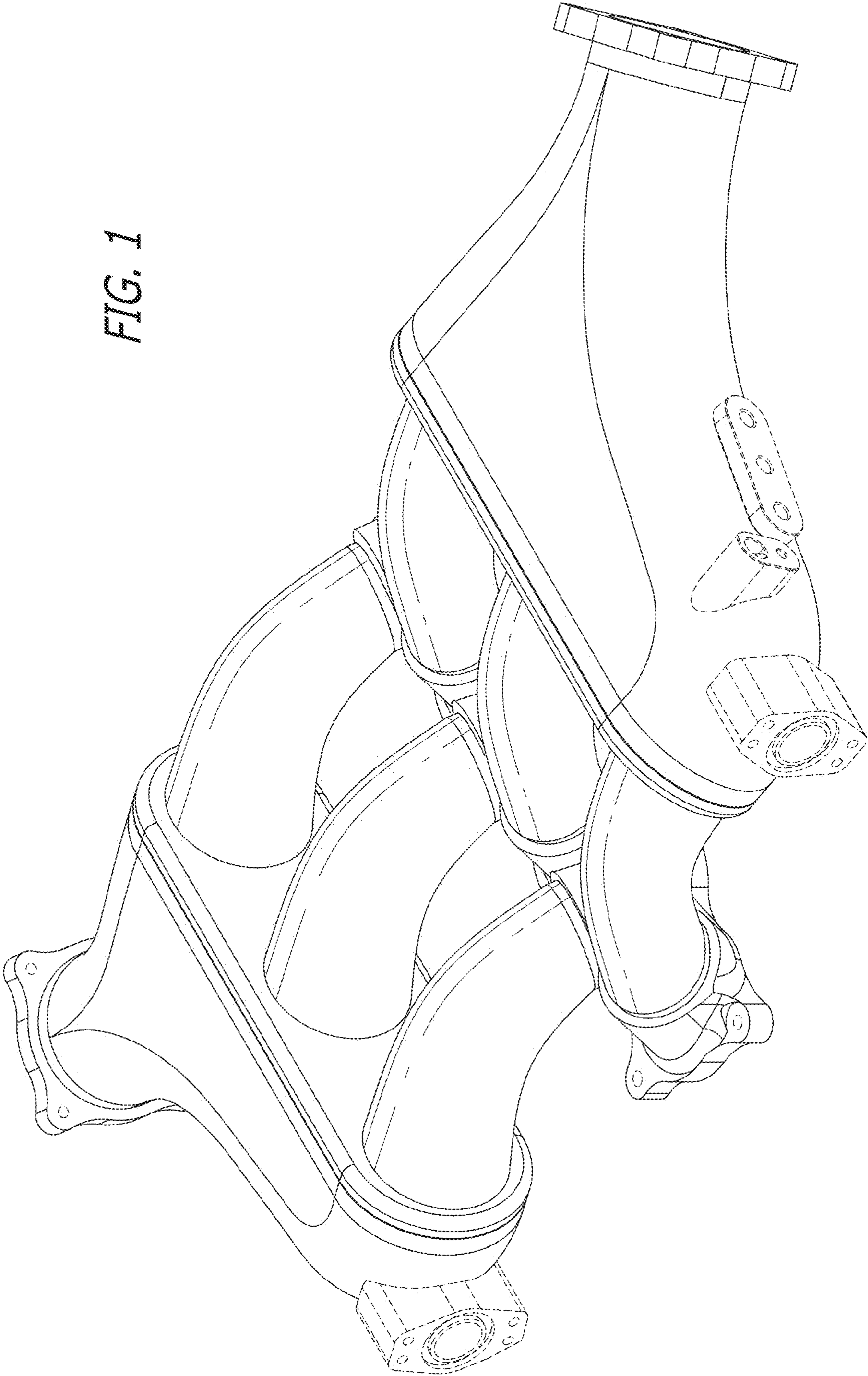
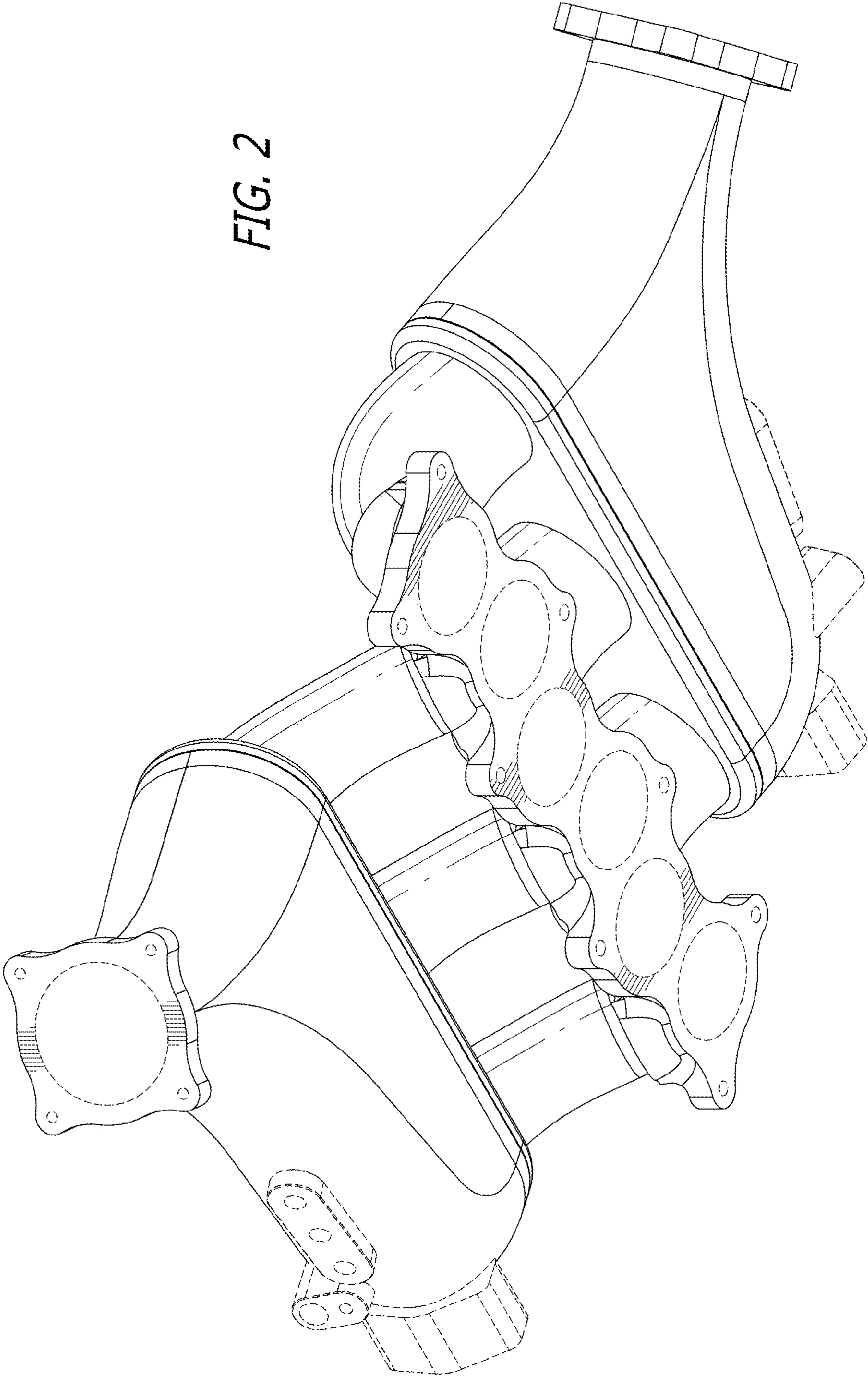

FIG. 2



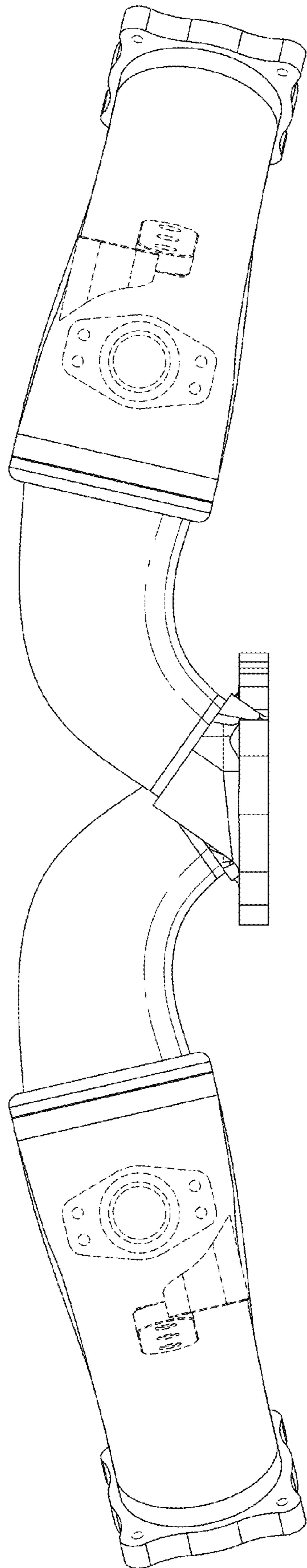

FIG. 3

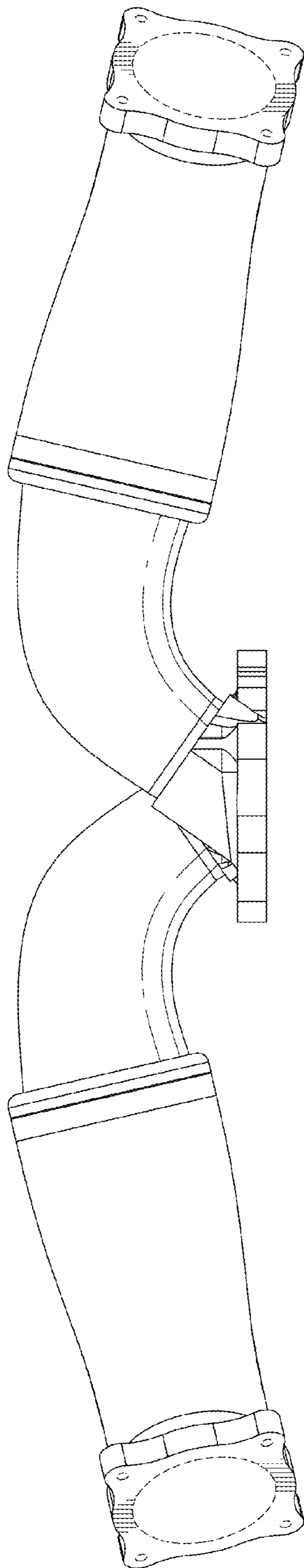

FIG. 4

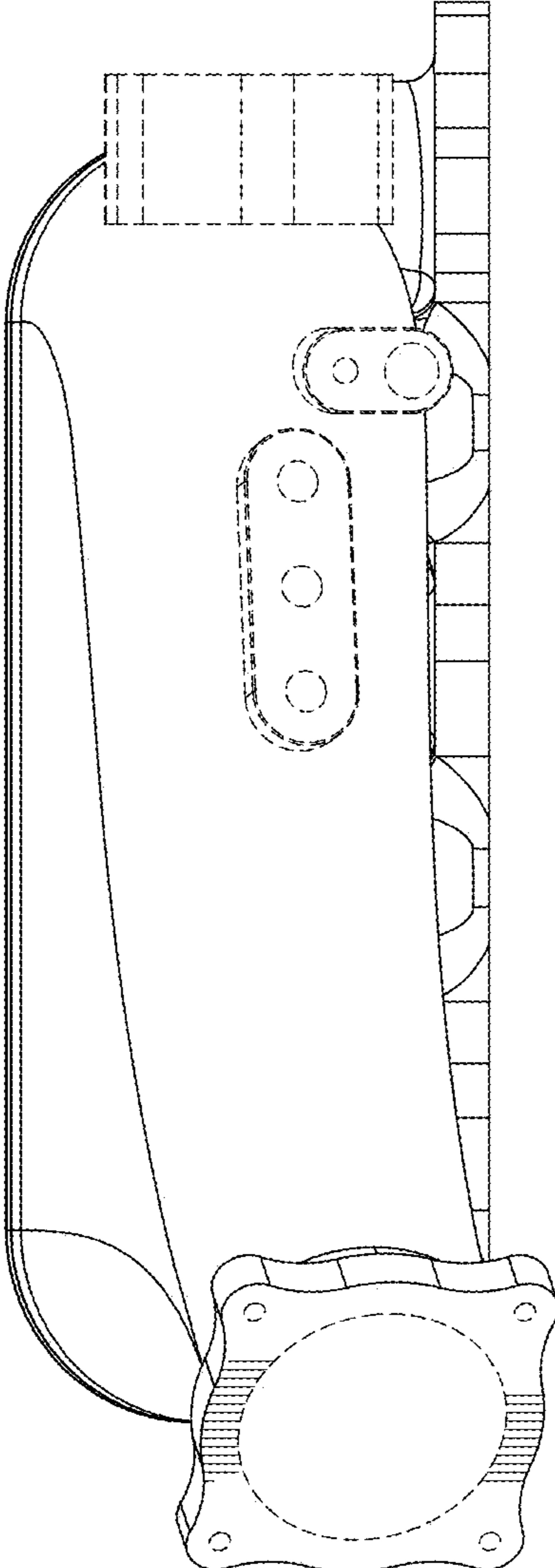

FIG. 5

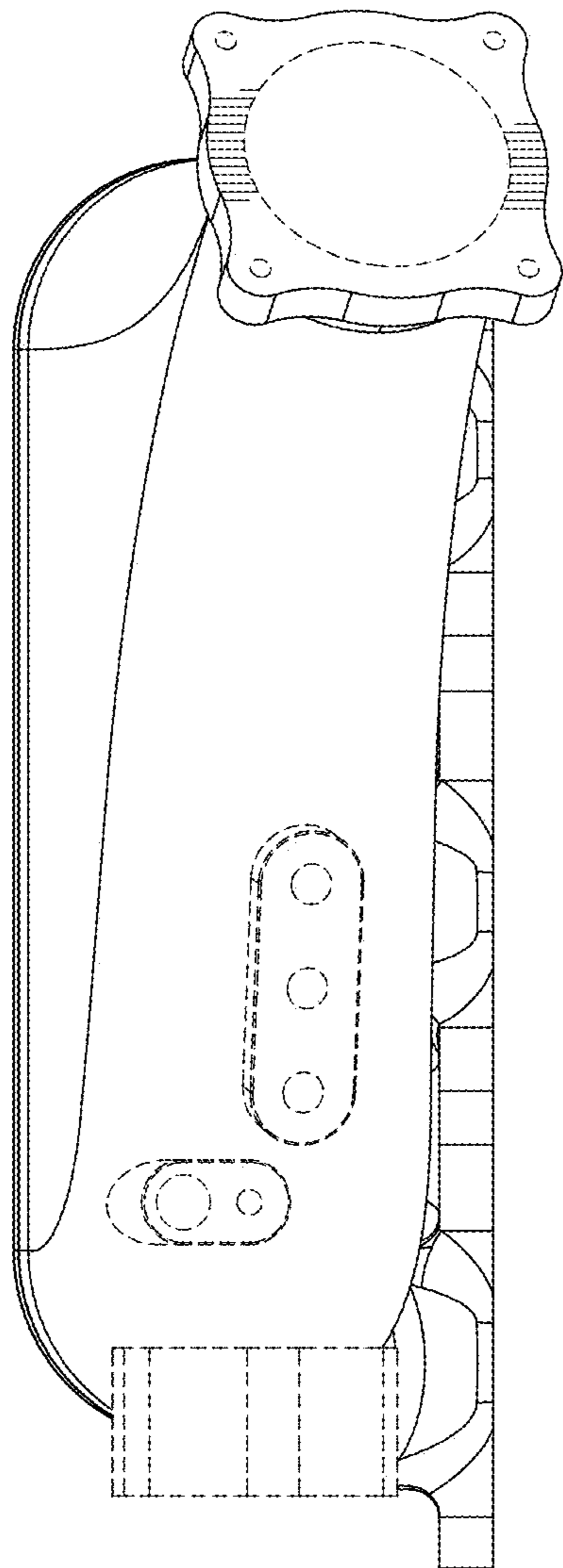

FIG. 6

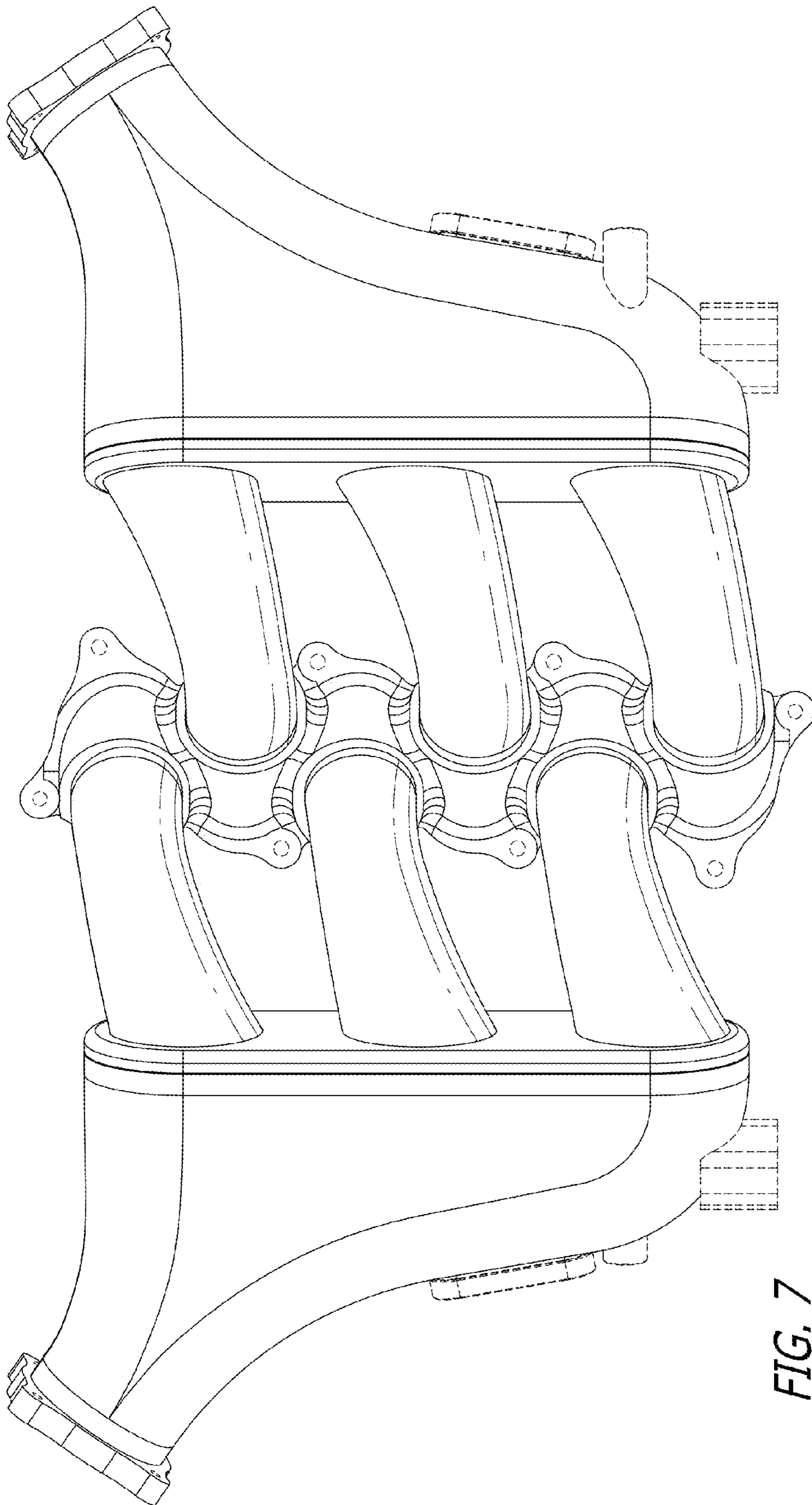

FIG. 7

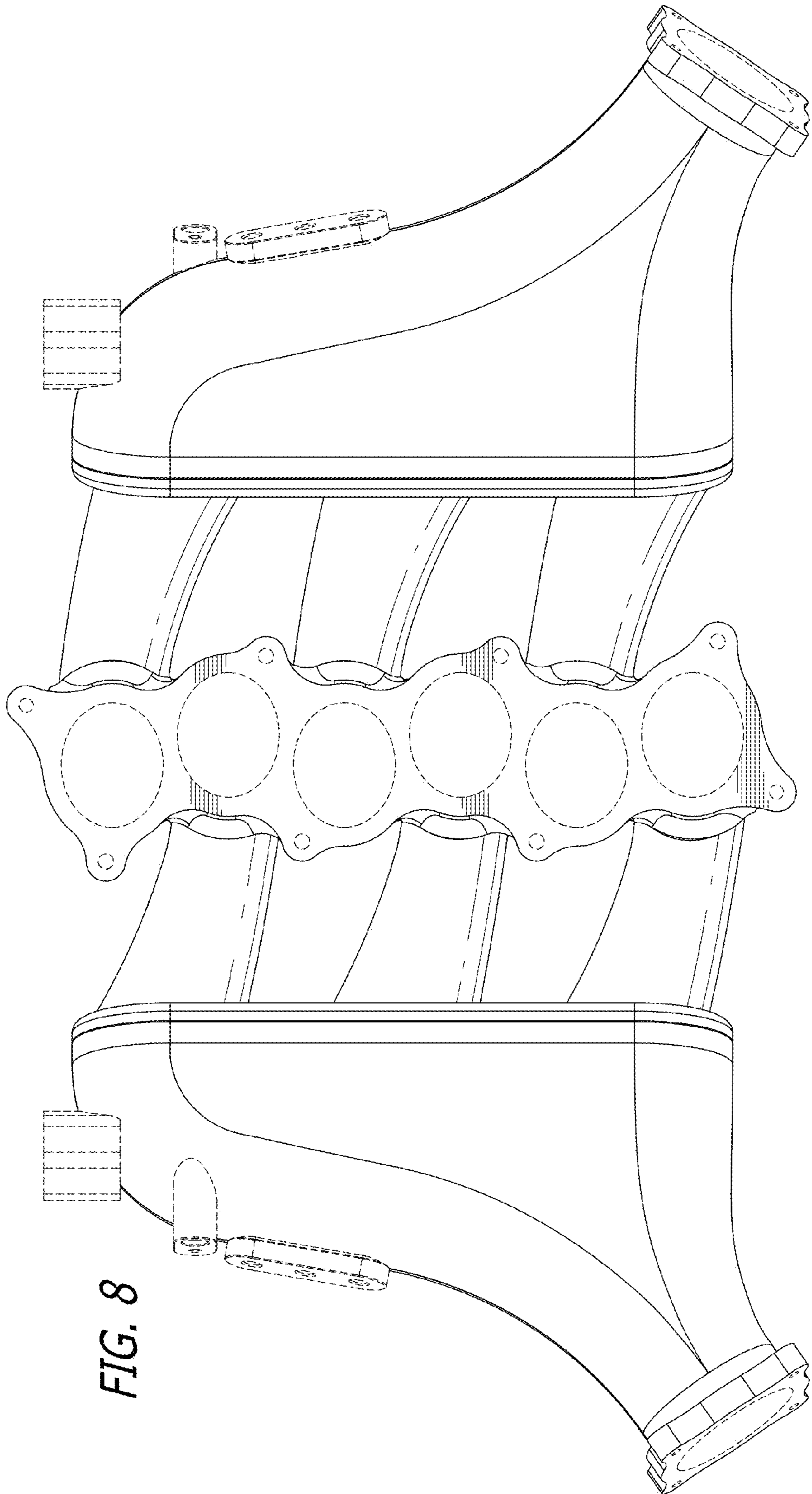

FIG. 8