



US00D892971S

(12) **United States Design Patent** (10) **Patent No.:** **US D892,971 S**
Wettig et al. (45) **Date of Patent:** **** Aug. 11, 2020**

(54) **EXPANSION TANK SPLIT FOR AUTOMOTIVE APPLICATIONS**

(71) Applicant: **RESOURCE INTERNATIONAL INC.**, New Castle, DE (US)

(72) Inventors: **Jason Wettig**, Abingdon, MD (US);
Steve Wiley, Bear, DE (US)

(**) Term: **15 Years**

(21) Appl. No.: **29/666,414**

(22) Filed: **Oct. 12, 2018**

(51) **LOC (12) Cl.** **23-01**

(52) **U.S. Cl.**
USPC **D23/202; D15/5**

(58) **Field of Classification Search**
USPC D23/201, 202, 206, 211.1, 223-227, 247;
D30/121, 132
CPC A01K 7/00; B05B 9/08; B05B 9/0805;
B05B 9/0811; B05B 9/0816; B05B
9/0822

See application file for complete search history.

(56) **References Cited**

U.S. PATENT DOCUMENTS

D208,539 S *	9/1967	Miller	D12/218
D250,948 S *	1/1979	Pickering	D12/218
D358,194 S *	5/1995	Schroeder	D23/200
D378,950 S *	4/1997	McKee	D12/218
D445,477 S *	7/2001	Pomier	D23/207
D628,672 S *	12/2010	Kendall	D23/202
D647,168 S *	10/2011	Lerner	D23/202
D701,814 S *	4/2014	Merchant	F01P 11/029
				D12/218
2018/0283261 A1 *	10/2018	Morishita	F01P 11/029
2019/0170053 A1 *	6/2019	Mark	F01P 7/165

OTHER PUBLICATIONS

Summitracing.com, Canton Racing Coolant Expansion and Recovery Tank 80-240SBLK, undated online product page, retrieved Feb. 13, 2020 from <URL:https://www.summitracing.com/parts/ctr-80-240sblk> (Year: 2020).*

Summitracing.com, Moroso Cooling System Expansion tanks 63783, undated online product page, retrieved Feb. 13, 2020 from <URL:https://www.summitracing.com/parts/mor-63783> (Year: 2020).*

* cited by examiner

Primary Examiner — Sheryl Lane

Assistant Examiner — Calvin E Vansant

(74) *Attorney, Agent, or Firm* — Cozen O'Connor

(57) **CLAIM**

The ornamental design for an expansion tank split for automotive applications, as shown and described.

DESCRIPTION

FIG. 1 is a front view of an expansion tank split for automotive applications showing our new design; FIG. 2 is a back view thereof; FIG. 3 is a right view thereof; FIG. 4 is a left view thereof; FIG. 5 is a top view thereof; FIG. 6 is bottom view thereof; and, FIG. 7 is a perspective view thereof.

The broken lines in the drawing figures show portions of the expansion tank split for automotive applications which form no part of the claimed design.

The shade lines in the figures show contour and not surface ornamentation.

1 Claim, 7 Drawing Sheets

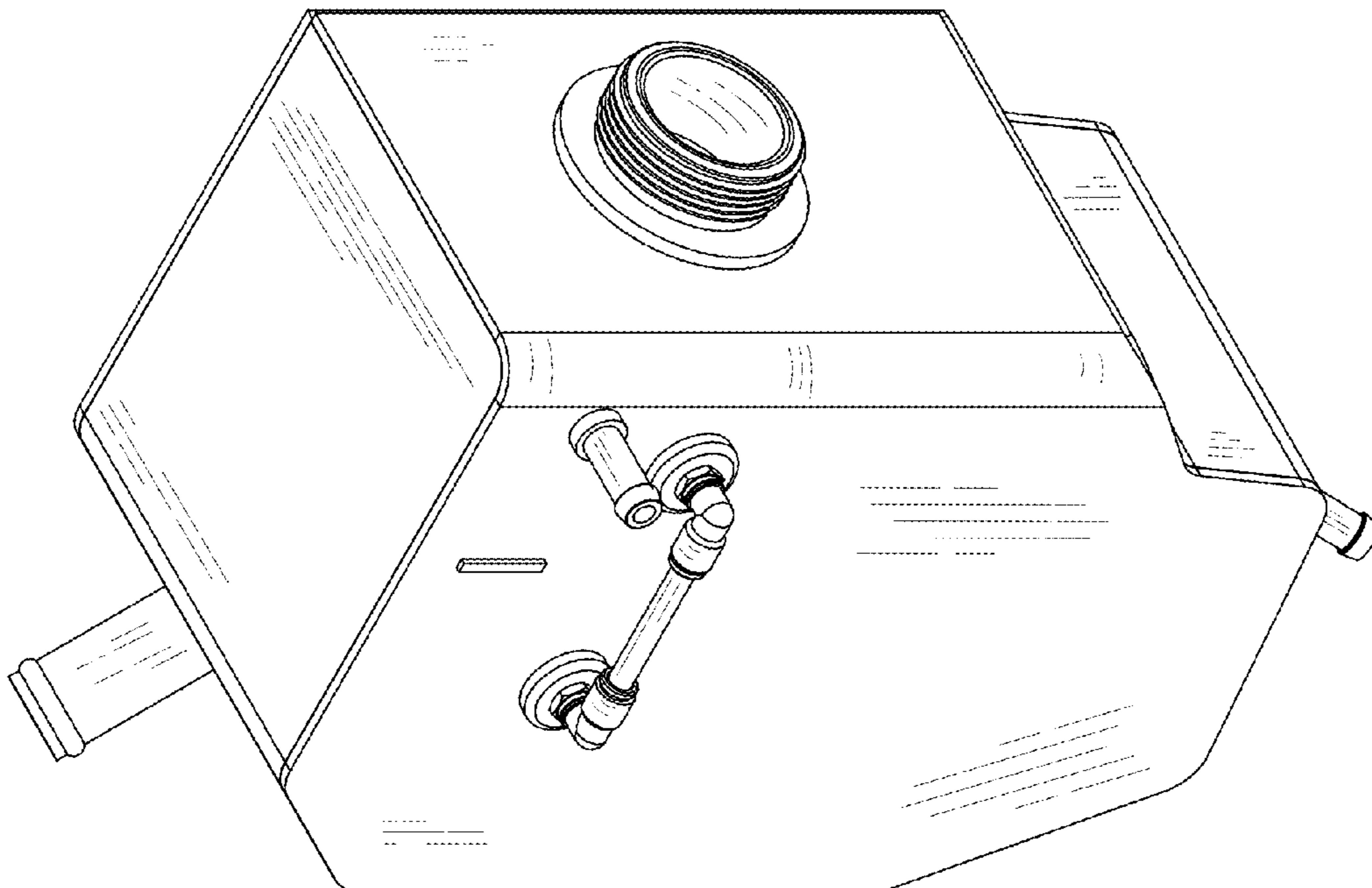

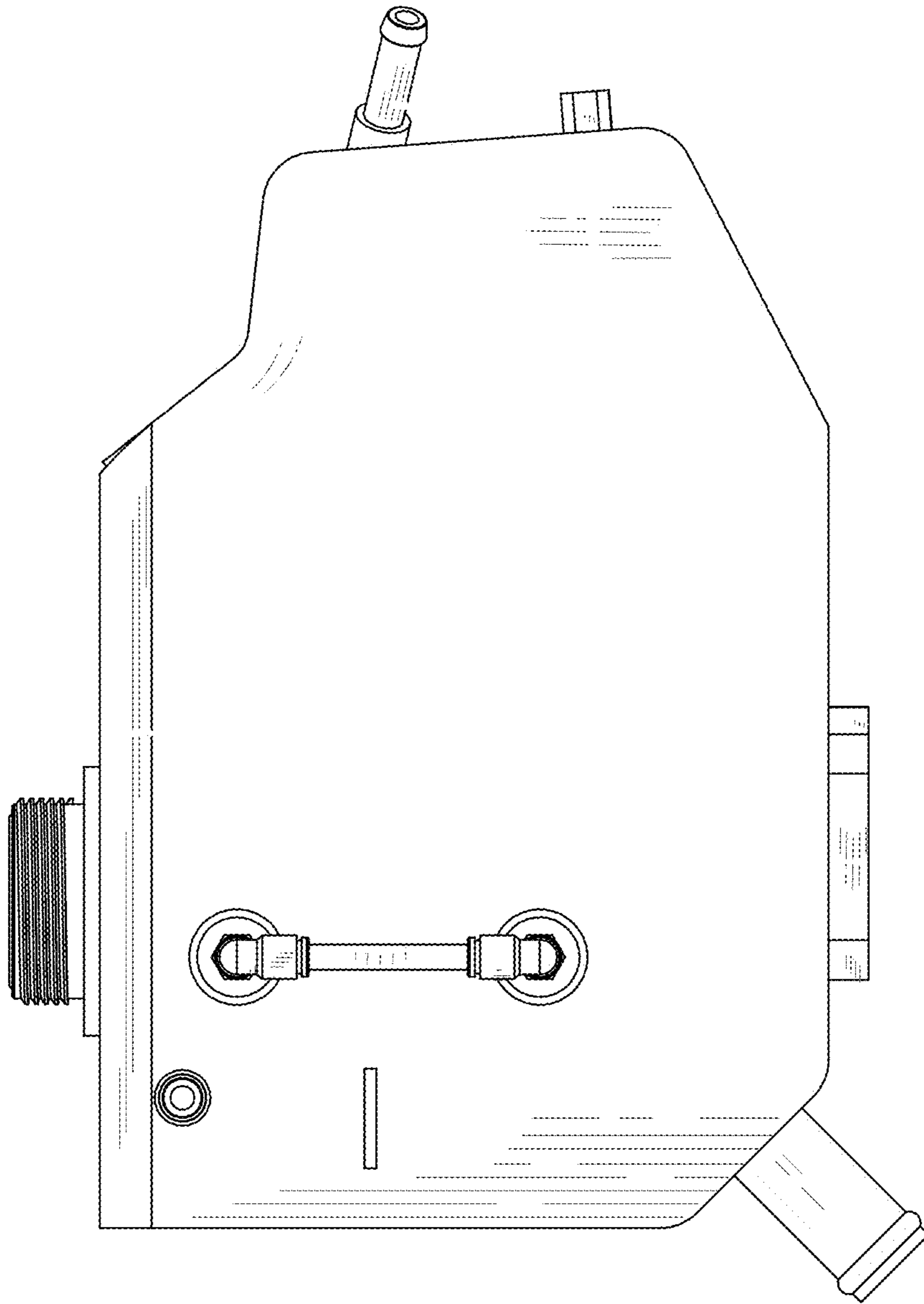

FIGURE 1

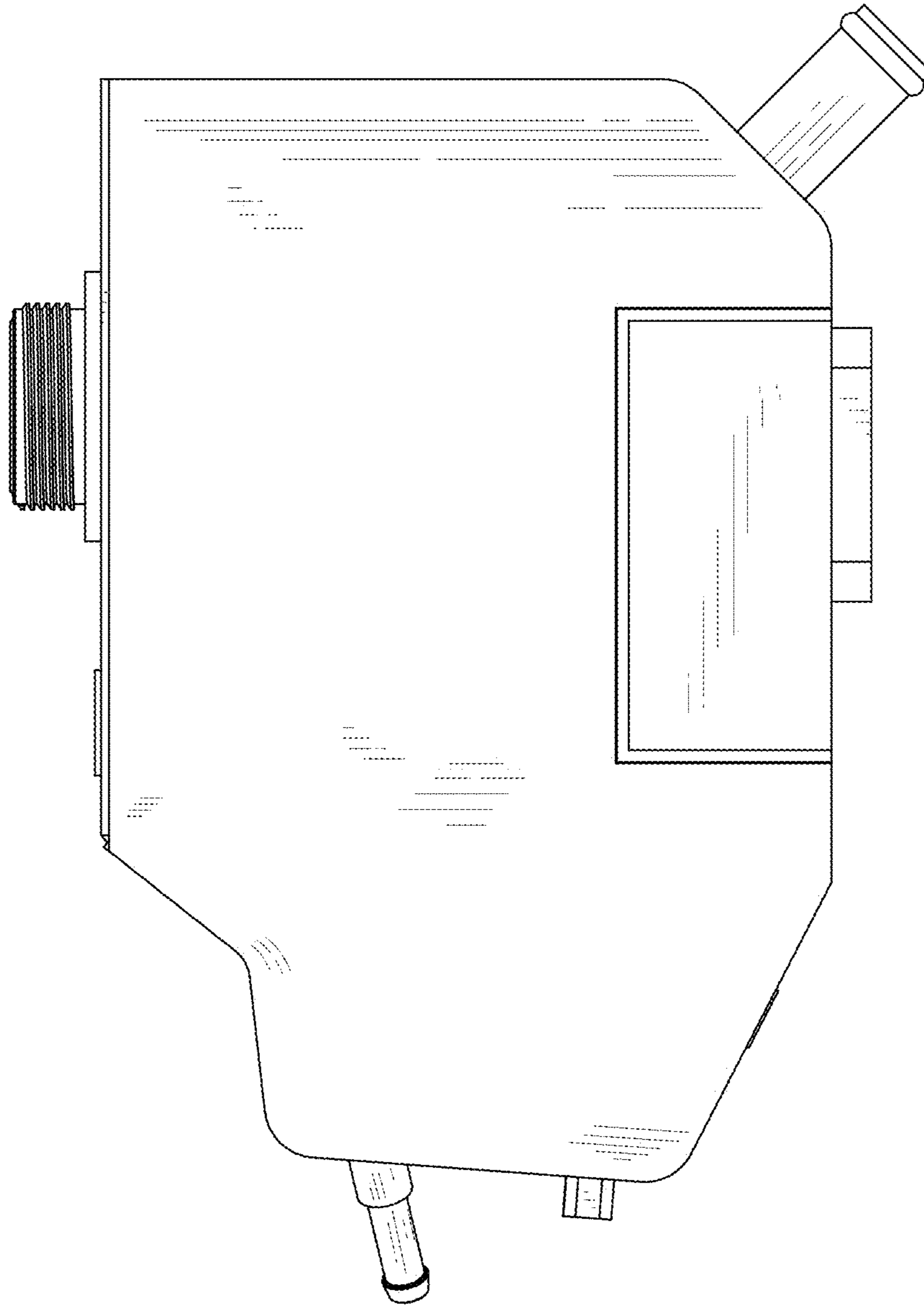

FIGURE 2

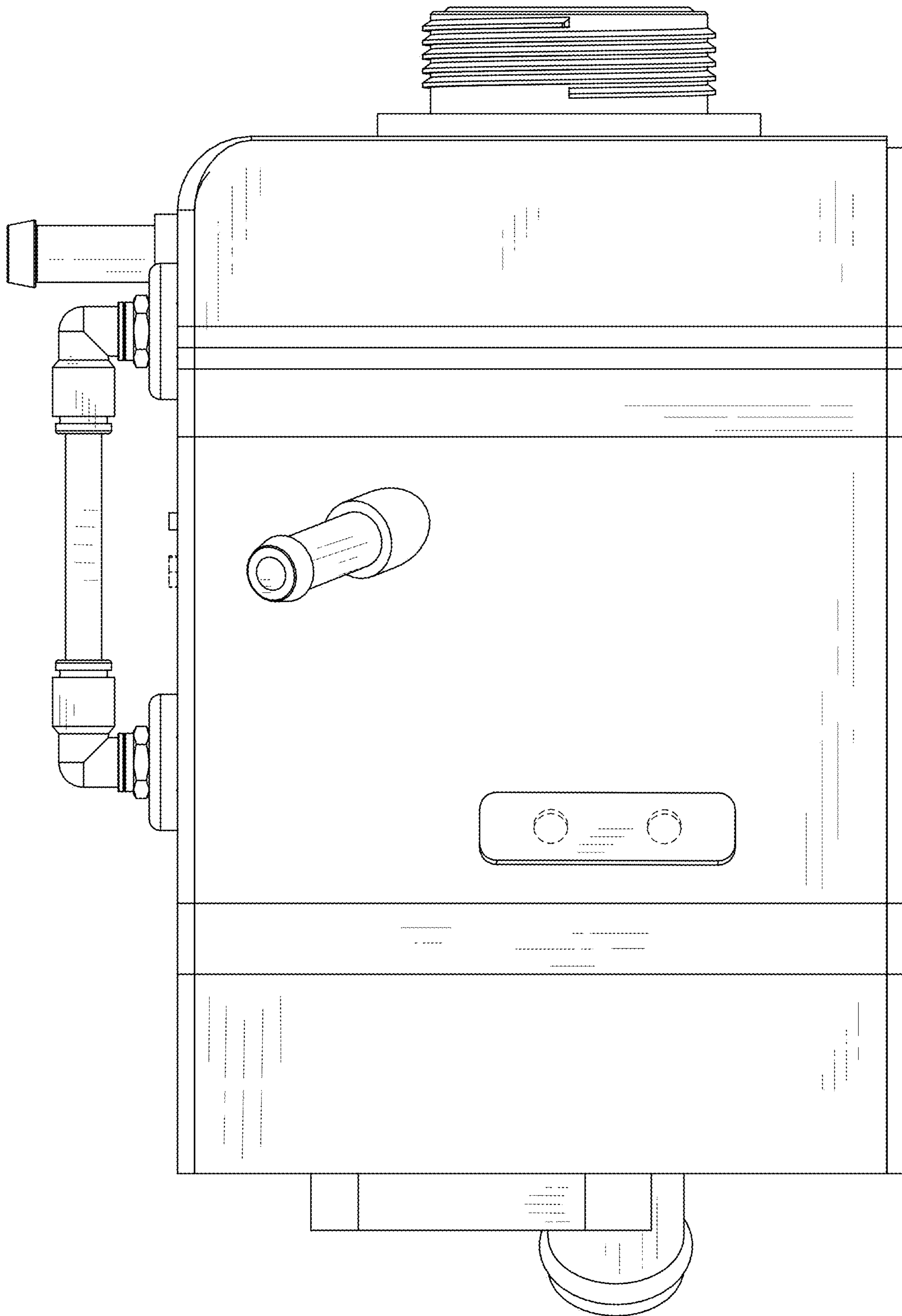

FIGURE 3

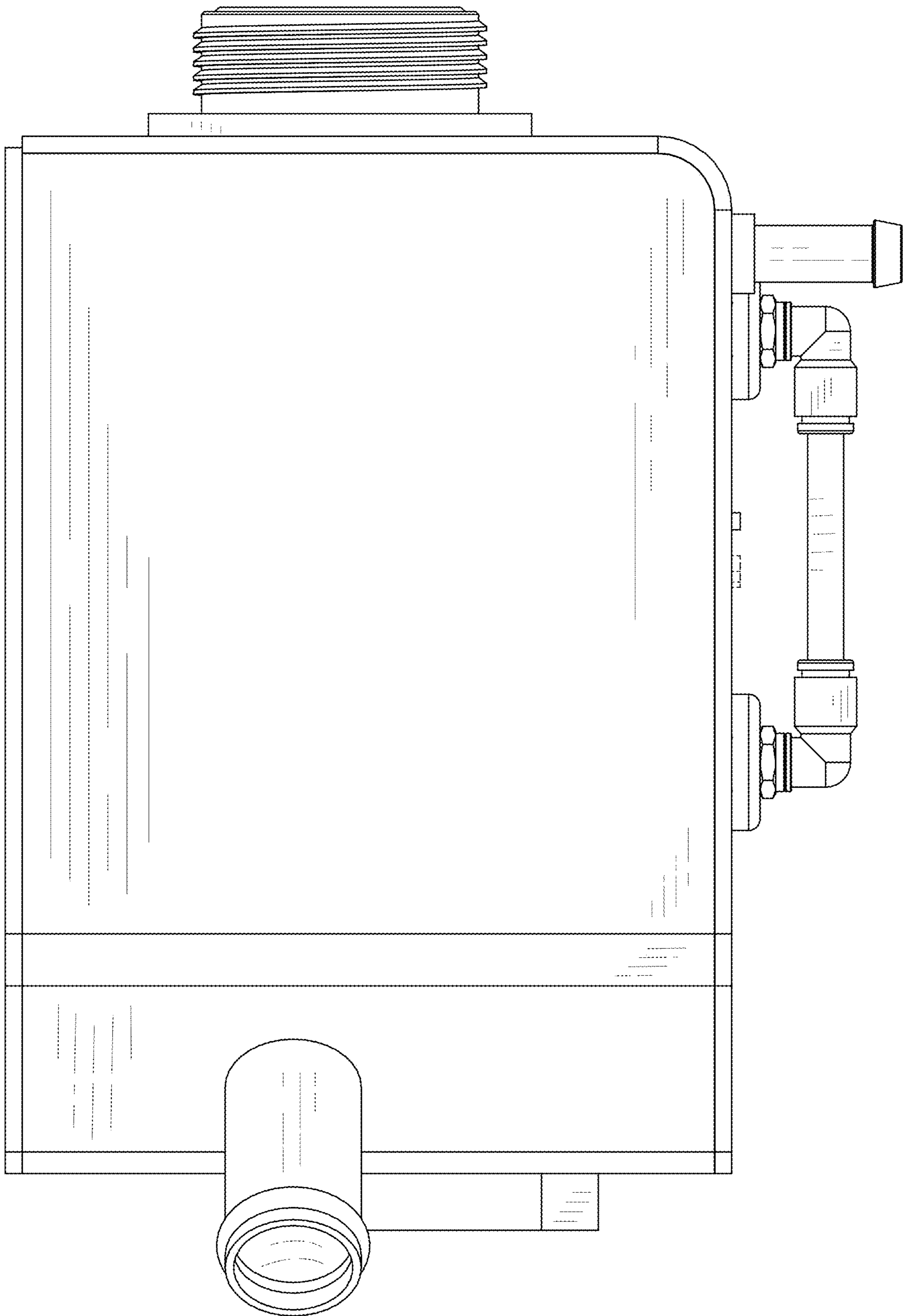

FIGURE 4

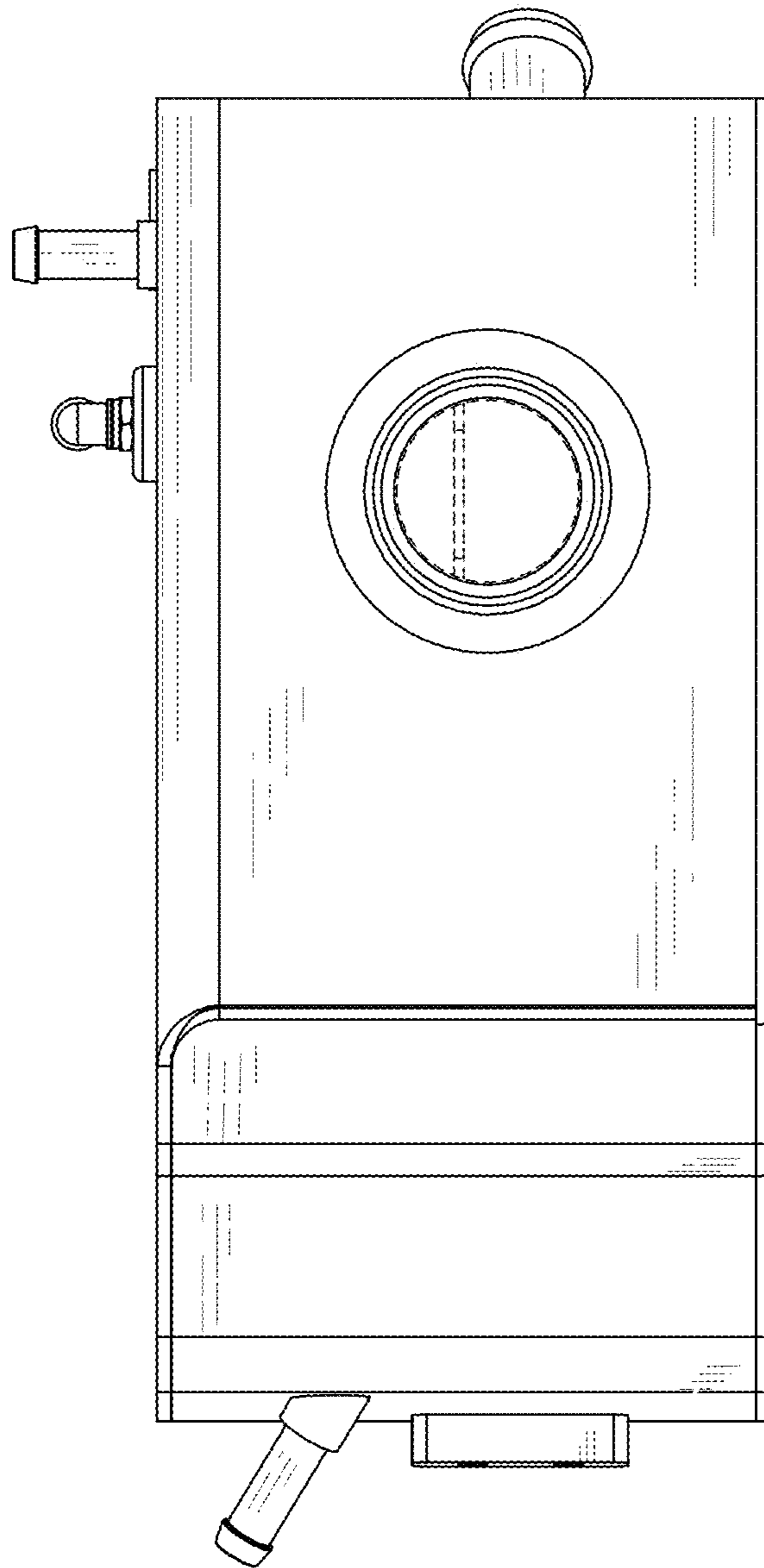

FIGURE 5

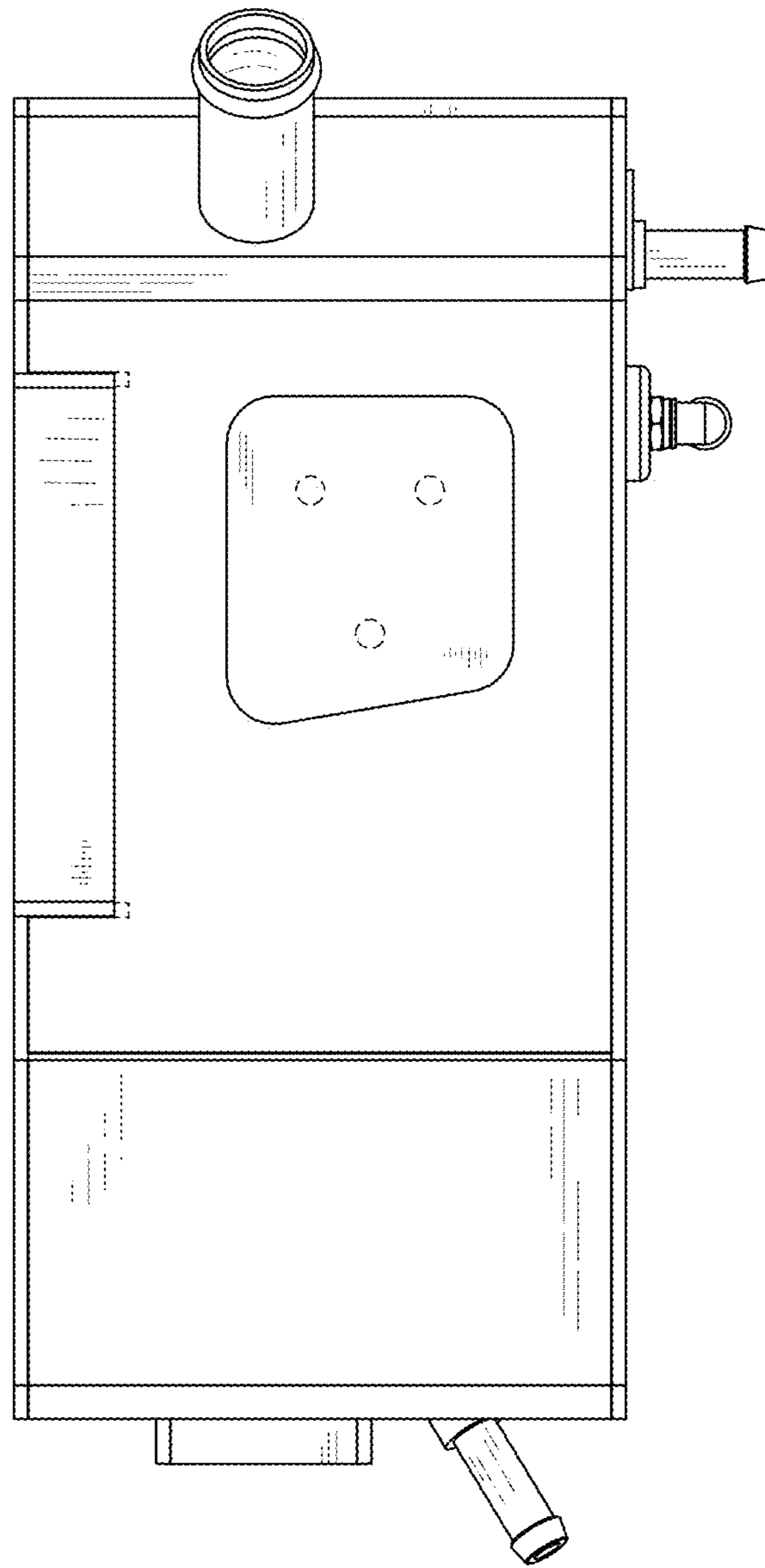

FIGURE 6

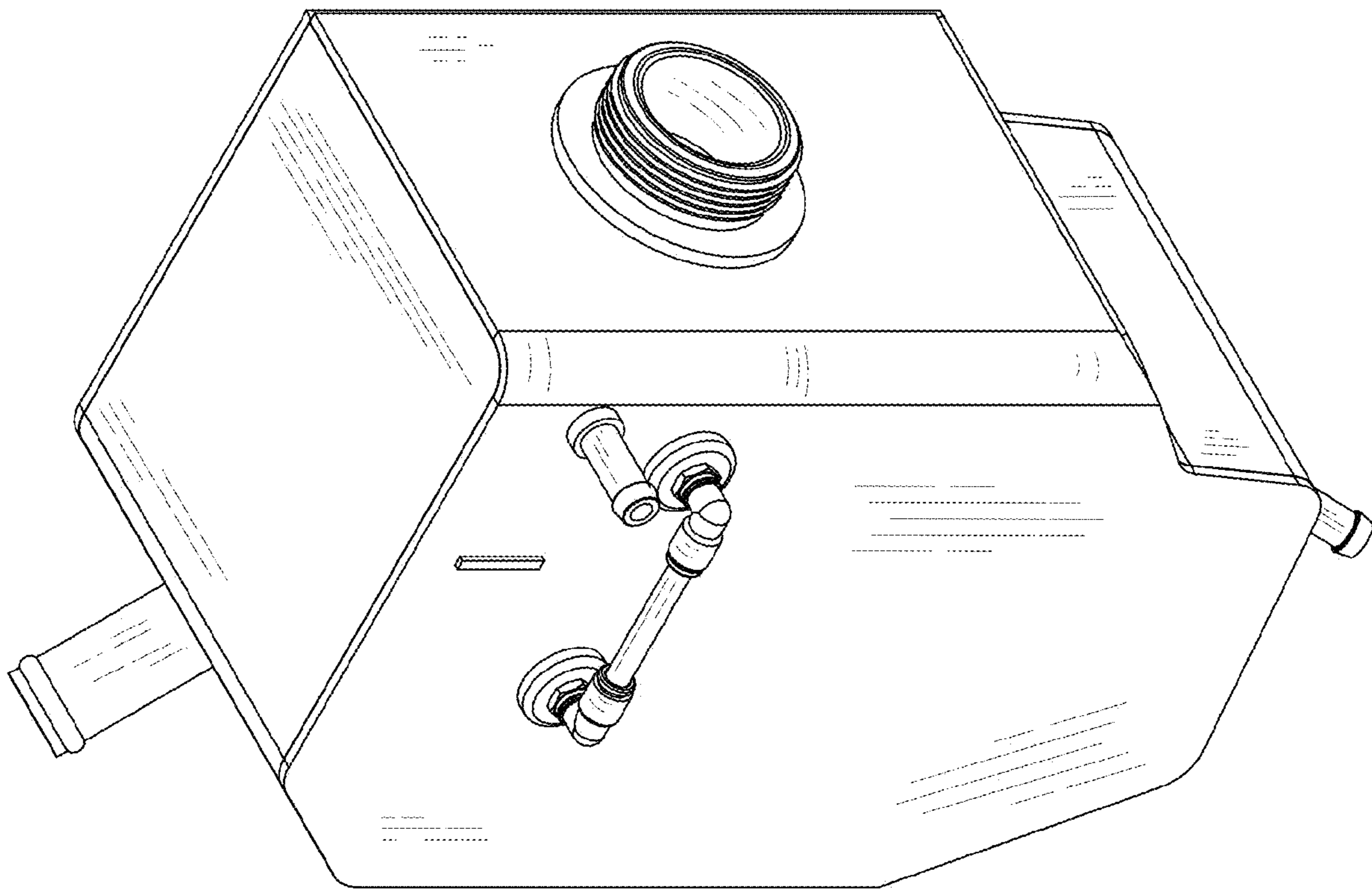

FIGURE 7