



US00D892773S

(12) **United States Design Patent** (10) **Patent No.:** **US D892,773 S**
McGee (45) **Date of Patent:** **** Aug. 11, 2020**

(54) **SECURE MICROPHONE LOCK CLIP**
(71) Applicant: **Michael Dale McGee**, Lake Havasu City, AZ (US)
(72) Inventor: **Michael Dale McGee**, Lake Havasu City, AZ (US)
(**) Term: **15 Years**
(21) Appl. No.: **29/675,011**
(22) Filed: **Dec. 27, 2018**
(51) **LOC (12) Cl.** **14-01**
(52) **U.S. Cl.**
USPC **D14/229**; D14/225
(58) **Field of Classification Search**
USPC D14/229, 225, 228, 432, 217; D17/99; D8/394, 373, 382, 395; D6/682, 552, D6/392, 566; 181/242; 379/451, 431, 379/433, 438, 424; 381/363, 359, 368, 381/361, 412, 386, 169, 168, 189, 355, 381/362; 84/421; 248/604, 634, 312.1, 248/311.2, 231.81, 301, 314, 229, 231, 248/16, 382, 316.7; 211/89.01, 69.8; 455/90.3, 575.1, 569.1; D11/148; 206/338; 439/246, 248, 188, 63, 578
CPC H04R 25/00; H04R 9/08; H04R 11/04; H04R 17/02; H04R 19/04; H04R 1/02; H04R 9/04; F16M 13/02; G10D 9/00; G10D 13/02; H04M 1/04; A47F 5/00; B65D 25/00; E04G 5/06
See application file for complete search history.

(56) **References Cited**
U.S. PATENT DOCUMENTS
1,403,707 A * 1/1922 Quarnstrom F21L 15/08 362/396
1,540,291 A * 6/1925 Sessions A47L 13/512 248/113

1,601,054 A * 9/1926 Wilson A47G 25/10 211/32
2,009,991 A * 8/1935 Anderson D06F 55/00 24/485
2,628,054 A * 2/1953 Fazakerley B60N 3/103 248/311.2
D181,851 S * 1/1958 Hendrickson D7/620
3,024,511 A * 3/1962 Schlueter F16B 5/0635 24/569
D201,468 S * 6/1965 Schwartz D16/242
D213,567 S * 3/1969 Kahn D14/228
3,433,905 A * 3/1969 Pless G11B 5/00 381/366
3,452,955 A * 7/1969 Hartwig H04R 1/08 248/229.26
3,521,332 A * 7/1970 Kramer F16B 2/22 403/188
3,566,047 A * 2/1971 Weingartner H04R 1/08 381/170
D223,579 S * 5/1972 Plice D14/229
D228,304 S * 9/1973 Lerew D7/620
D228,877 S * 10/1973 Hirt D8/394
3,907,239 A * 9/1975 Ehrlich F16B 2/245 248/229.26
3,928,734 A * 12/1975 Noury, Jr. H04R 1/08 381/364

(Continued)

Primary Examiner — Paula Allen Greene

(57) **CLAIM**

The ornamental design for a secure microphone lock clip, as shown and described.

DESCRIPTION

FIG. 1 is a front perspective view of a secure microphone lock clip showing my new design; FIG. 2 is a rear perspective view thereof; FIG. 3 is a left side perspective view thereof; FIG. 4 is a right side perspective view thereof; FIG. 5 is a bottom perspective view thereof; and, FIG. 6 is a bottom perspective view thereof.

1 Claim, 6 Drawing Sheets

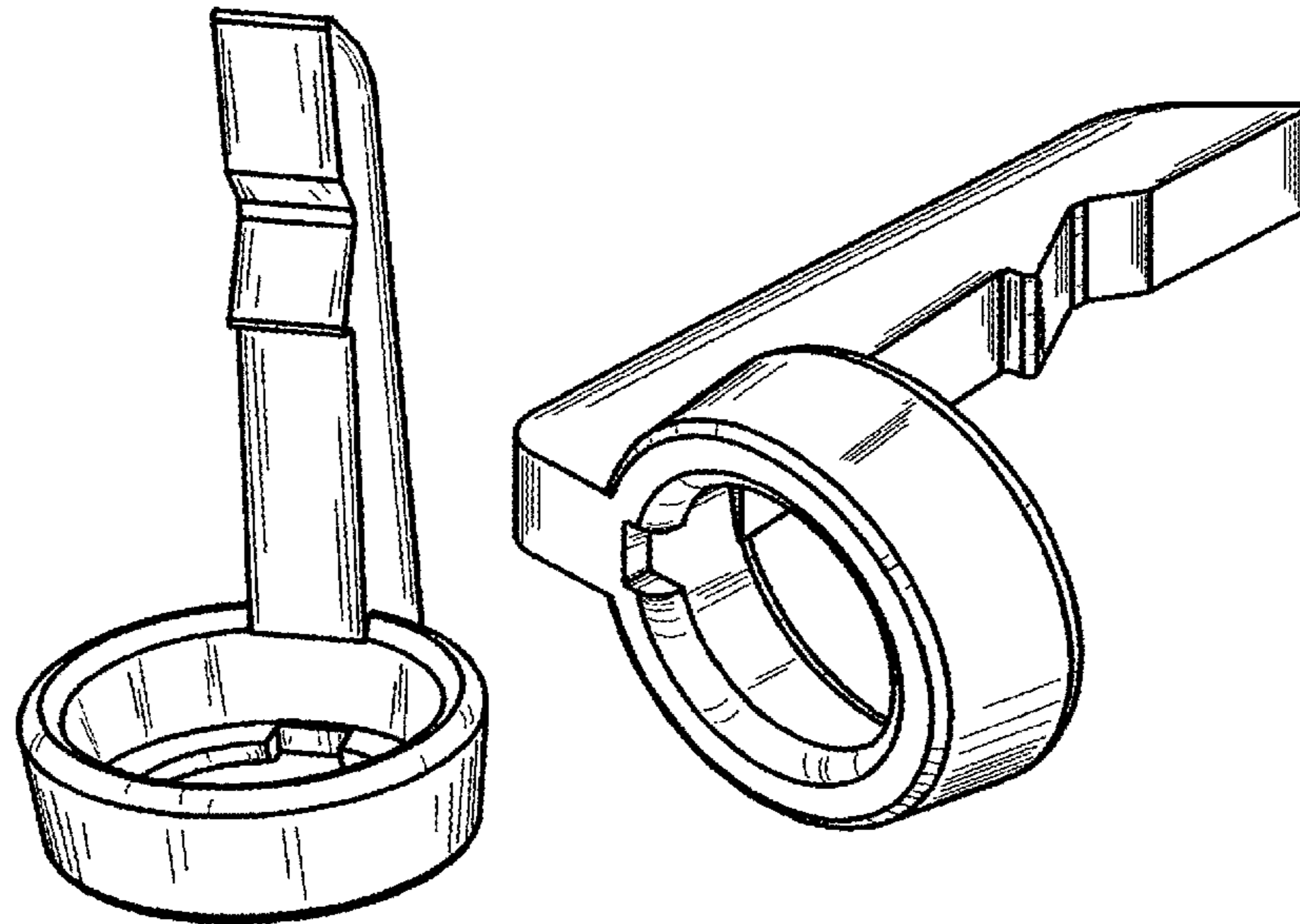

(56)

References Cited

U.S. PATENT DOCUMENTS

D243,441 S *	2/1977	Podd	D8/367
D244,551 S *	5/1977	Weiss	D14/225
4,040,547 A *	8/1977	Dickey	F16M 13/04 224/247
D246,899 S *	1/1978	Bruce	D14/229
4,295,009 A *	10/1981	Weidler	H04R 17/00 310/324
4,312,487 A *	1/1982	Kimura	F16L 3/1236 206/338
4,370,800 A *	2/1983	Kuzmin	H02K 9/19 29/598
4,429,247 A *	1/1984	Feldman	H04R 17/00 310/322
4,546,950 A *	10/1985	Cech	F16F 1/46 211/60.1
D282,704 S *	2/1986	Burnett	D30/133
4,577,070 A *	3/1986	Shulman	H04R 1/08 248/104
D291,650 S *	9/1987	Monzen	D24/128
4,811,405 A *	3/1989	Peiker	H04R 1/08 381/365
D301,545 S *	6/1989	Wrigley	D13/129
4,844,400 A *	7/1989	Jasmagy, Jr.	B60N 3/103 248/311.2
4,991,220 A *	2/1991	Wolf	H04R 1/08 381/361
4,993,675 A *	2/1991	Walker	A47G 23/0266 220/737
D330,850 S *	11/1992	Roick	D8/367
D342,537 S *	12/1993	Olson	D16/132
D358,679 S *	5/1995	Garrity	D26/138
D389,050 S *	1/1998	Li	D8/395
5,761,299 A *	6/1998	Patterson	H01R 13/66 379/433.03
D422,045 S *	3/2000	Fell	D22/100
D467,160 S *	12/2002	Roick	D8/367
D478,738 S *	8/2003	Workman	D6/552
6,751,317 B2 *	6/2004	Shima	H01R 13/7033 379/438
D531,891 S *	11/2006	Nawrocki	D8/395
D538,794 S *	3/2007	Ho	D14/225
D541,636 S *	5/2007	Walker	D8/373
D554,927 S *	11/2007	Smith	D6/513
D605,639 S *	12/2009	Lee	D14/225
D608,189 S *	1/2010	Jackson	D8/395
D620,785 S *	8/2010	St. Germaine	D8/395
D623,631 S *	9/2010	Kung	D14/228
D669,773 S *	10/2012	Colasse	D8/395
D672,225 S *	12/2012	Virnig	D8/373
D710,831 S *	8/2014	Cooper	D14/229
D730,225 S *	5/2015	Behar	D10/103
D737,804 S *	9/2015	Fereday	D14/229
D739,223 S *	9/2015	Paik	D8/396
D751,558 S *	3/2016	Lee	D10/103
D754,778 S *	4/2016	Terashita	D16/242
D769,959 S *	10/2016	Jia	D14/228
D828,746 S *	9/2018	Barnes	D8/382
D834,932 S *	12/2018	Babbage	D8/394
D859,971 S *	9/2019	Tenander	D8/394
D873,651 S *	1/2020	Bancroft	D8/395

* cited by examiner

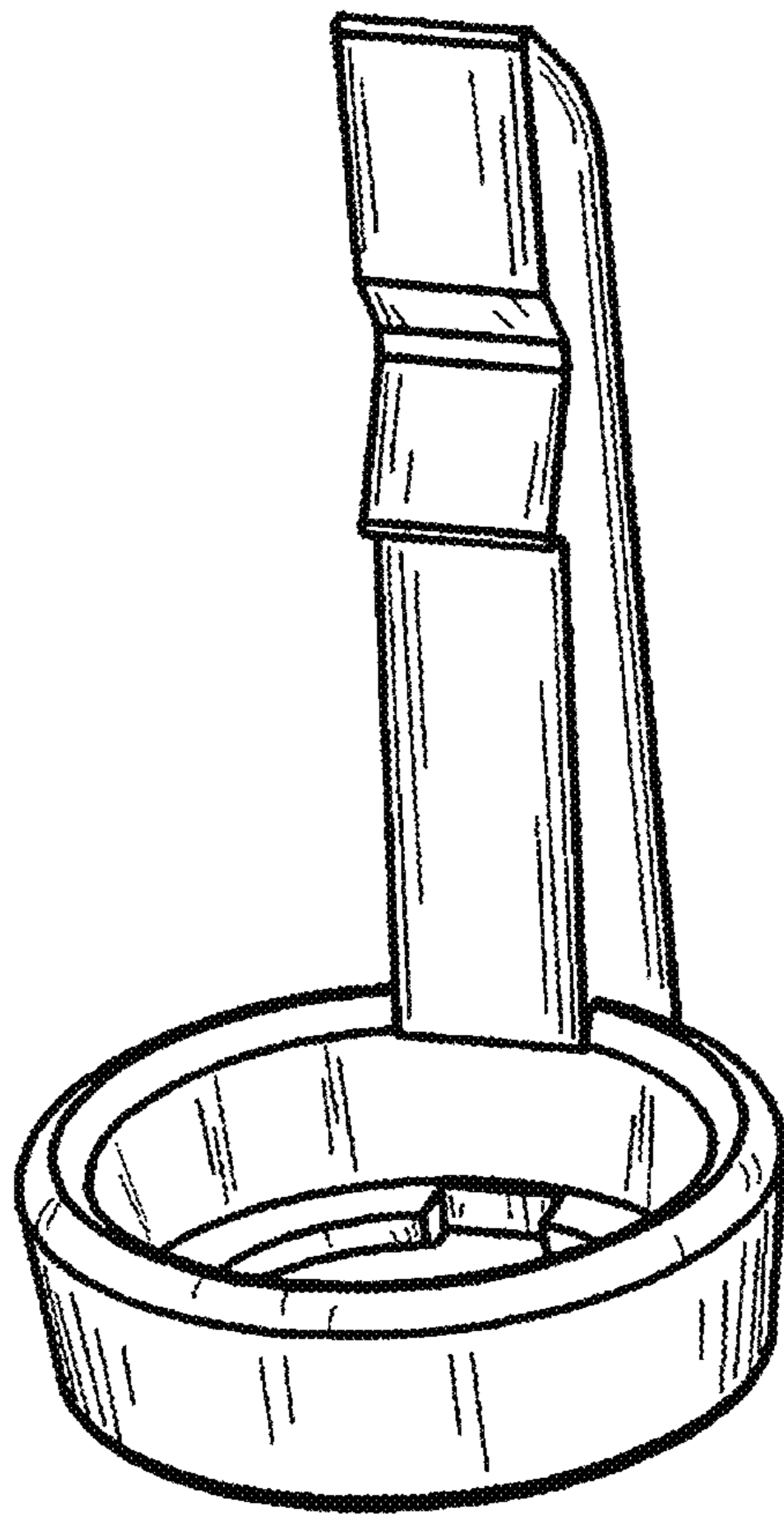

Fig. 1

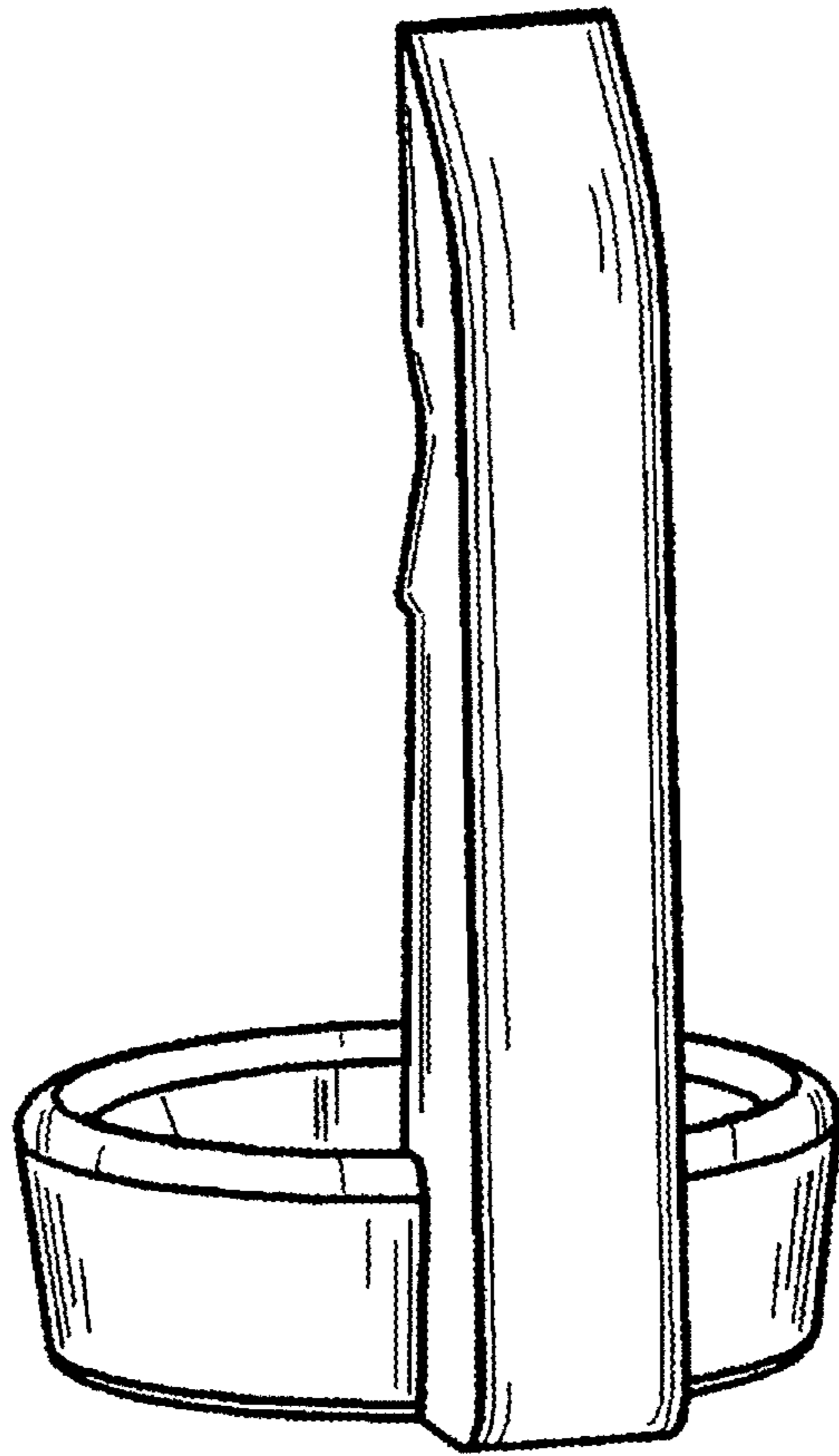

Fig. 2

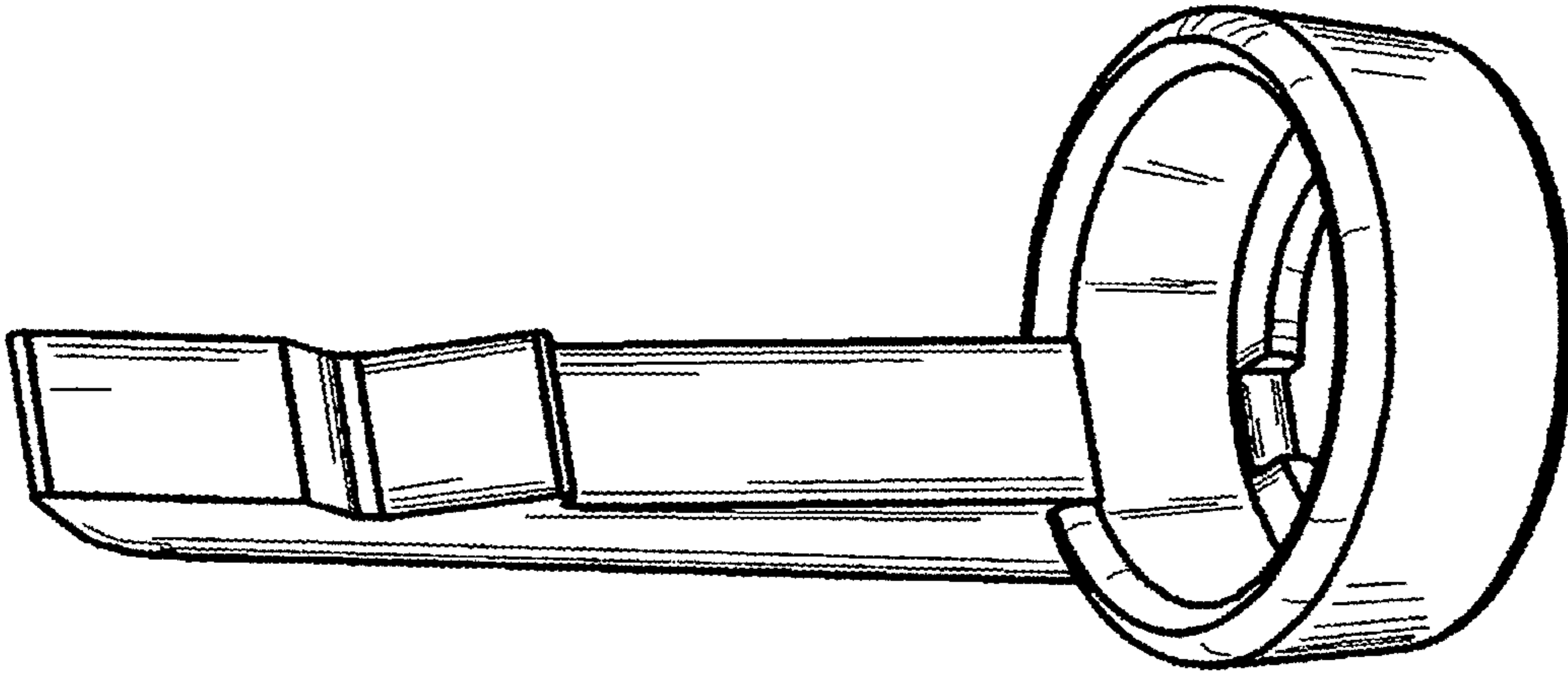

Fig. 3

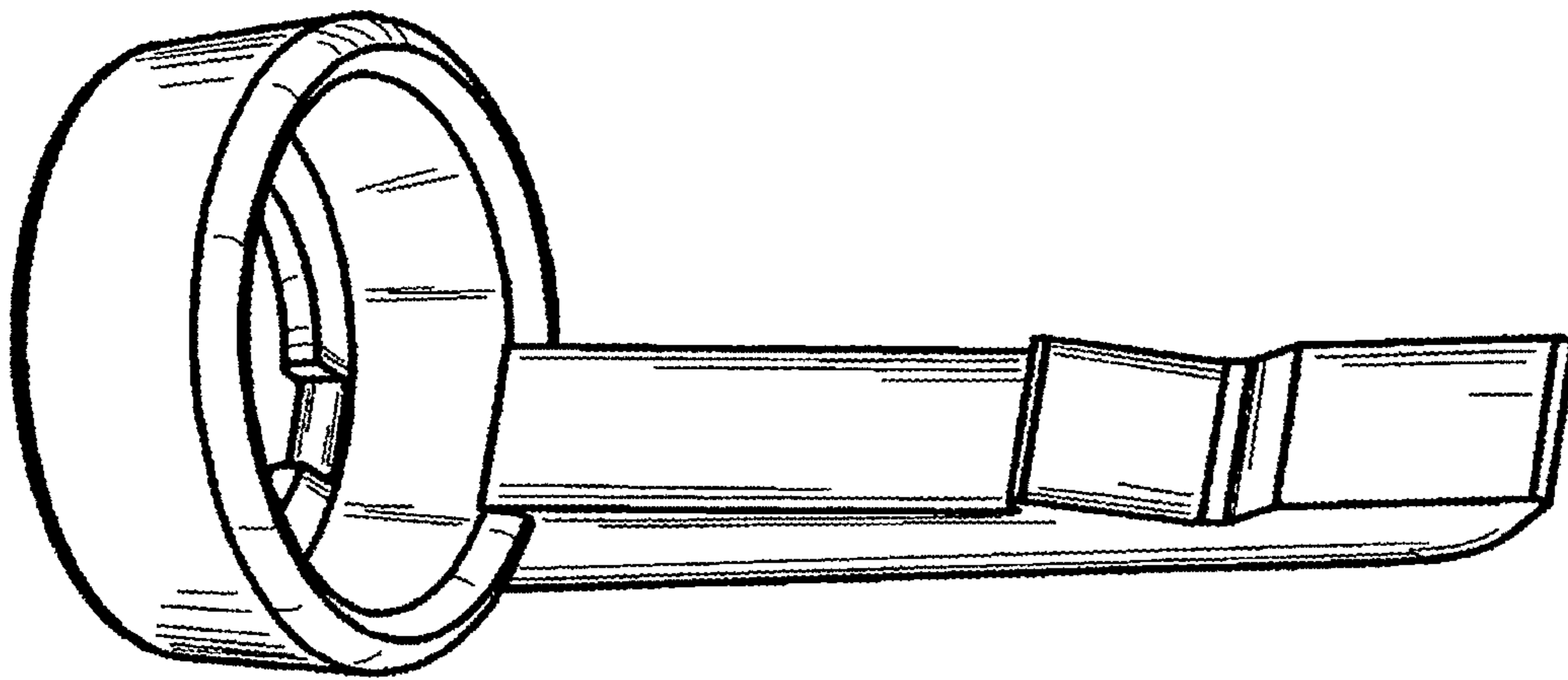

Fig. 4

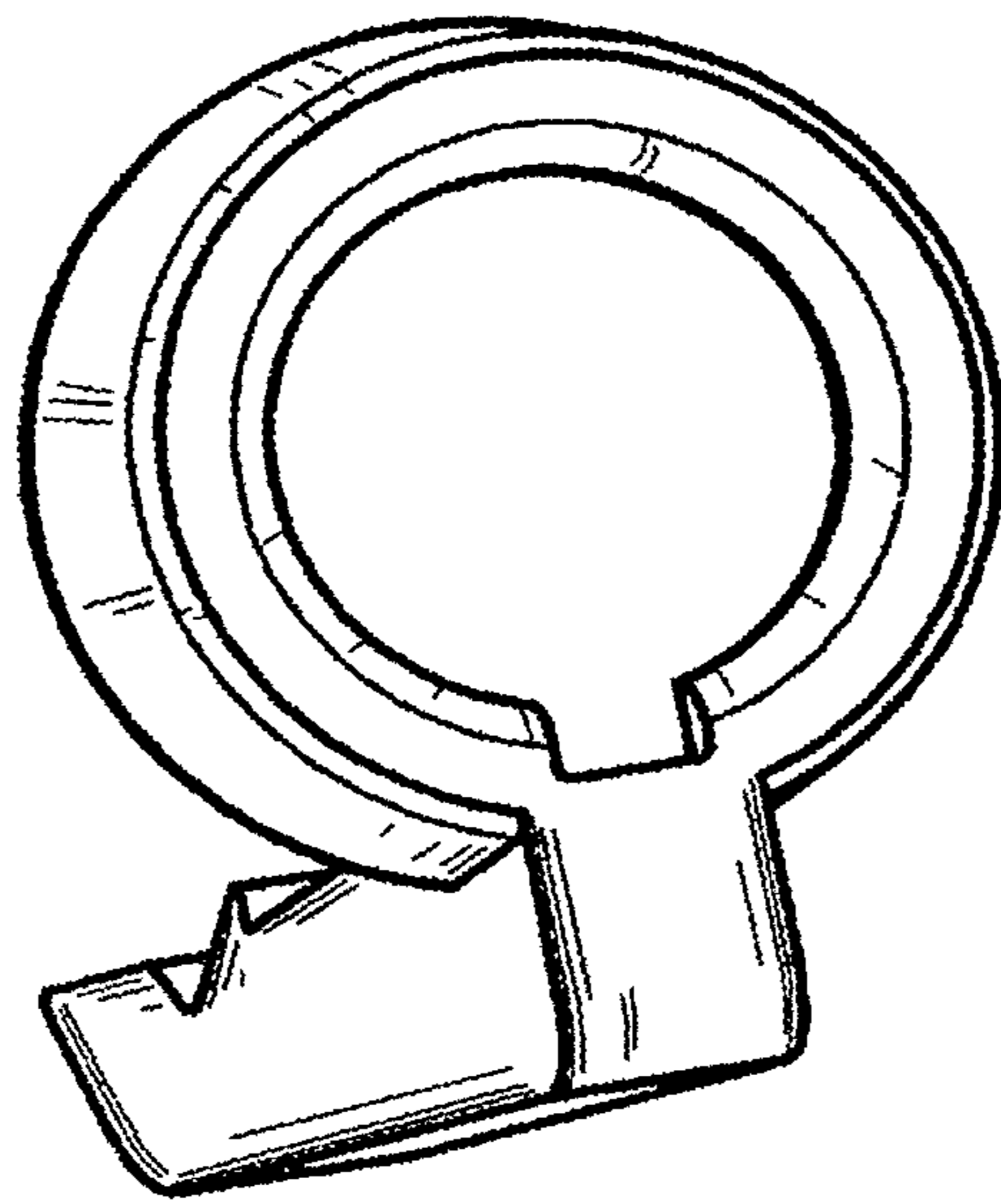

Fig. 5

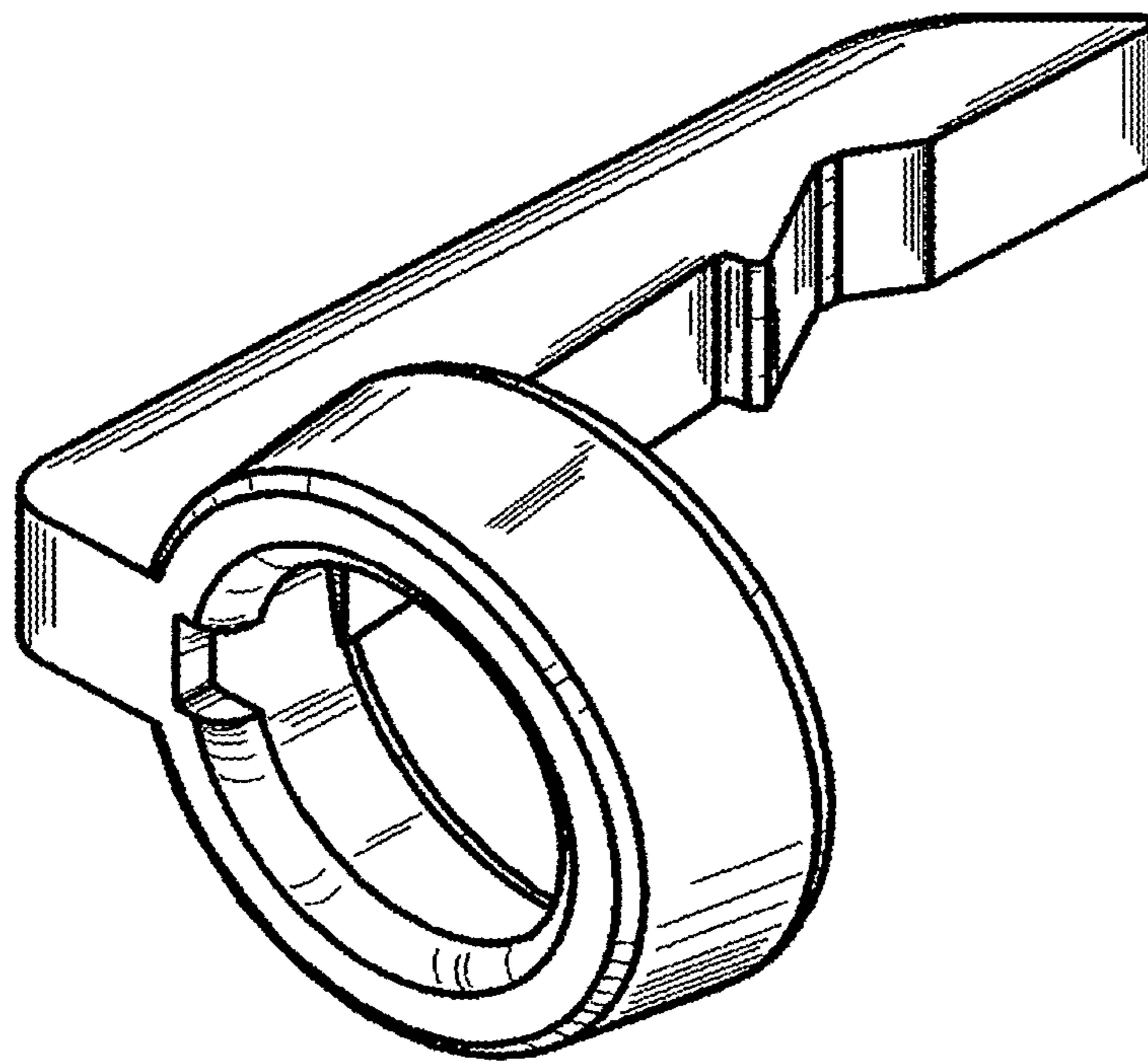

Fig. 6