



US00D892760S

(12) **United States Design Patent**
Aaron et al.

(10) **Patent No.:** **US D892,760 S**
(45) **Date of Patent:** **** Aug. 11, 2020**

(54) **WIRELESS NETWORKING CELL FOR MOUNTING ON AN AERIAL LIGHTING FIXTURE**

84/042; H04W 84/045; H04W 84/047;
H04M 1/72522; H04M 1/72525
See application file for complete search history.

(71) Applicant: **Ubicquia LLC**, Wellington, FL (US)

(56)

References Cited

(72) Inventors: **Ian B. Aaron**, Wellington, FL (US);
Ronald B. Zimmerman, III,
Wellington, FL (US); **Bradford Brian
Hutson**, Wellington, FL (US)

U.S. PATENT DOCUMENTS

(73) Assignee: **UBICQUIA LLC**, Fort Lauderdale, FL (US)

D201,825 S	8/1965	Heenan	
D214,706 S	7/1969	Kauffman	
D227,785 S	7/1973	Kaysen	
D237,369 S	10/1975	Lowndes	
D239,517 S	4/1976	Lowndes	
D242,778 S	12/1976	Goble et al.	
D242,779 S	12/1976	Goble et al.	
D242,942 S	1/1977	Brudy et al.	
4,503,360 A	3/1985	Bedel	
D286,988 S	12/1986	Akiyama et al.	
4,731,551 A *	3/1988	Gibbs	H05B 47/16 307/141

(**) Term: **15 Years**

(21) Appl. No.: **29/710,329**

(22) Filed: **Oct. 22, 2019**

Related U.S. Application Data

(62) Division of application No. 29/662,091, filed on Aug. 31, 2018, now Pat. No. Des. 871,361.

(51) **LOC (12) Cl.** **14-03**

(52) **U.S. Cl.**
USPC **D14/140.6**

(58) **Field of Classification Search**

USPC D14/140, 140.1, 140.2, 140.3, 140.4,
D14/140.5, 140.6, 142, 155, 168, 230,
D14/233, 240, 242, 243, 255, 299, 496,
D14/356, 358, 236; D13/123, 152, 154,
D13/158, 184, 199, 101, 110, 111, 112,
D13/114, 160; D10/46, 75, 103, 104.1,
D10/121, 106.1, 106.6, 106.3, 109.1,
D10/109.2, 111, 114.1, 114.2, 114.6,
D10/114.8; D26/72, 80, 81, 85, 88, 67,
D26/68-71, 113, 138

CPC F21S 8/006; F21S 8/08; F21S 8/081; F21S
8/032; F21S 8/085; F21S 8/086; F21S
8/088; F21S 9/03; F21S 9/032; F21S
9/035; F21S 9/037; F21V 23/04; F21V
23/0435; F21W 2131/109; H04W 88/08;
H04W 16/24; H04W 8/245; H04W

4,804,972 A	2/1989	Schudel	
D310,064 S	8/1990	Cheng	
D311,540 S	10/1990	Wickrema et al.	
D327,691 S	7/1992	Ogawa et al.	
D333,661 S	3/1993	Elliott et al.	
D336,864 S	6/1993	Gottlieb	
D346,170 S	4/1994	Tang	
D347,436 S	5/1994	Tang	
D349,256 S	8/1994	Bellinger et al.	
D390,566 S	2/1998	Martek et al.	
D401,175 S	11/1998	Bender et al.	
D402,991 S	12/1998	Mosser	
D404,326 S	1/1999	Bender et al.	
D411,640 S	6/1999	Lueken et al.	
D412,676 S	8/1999	Layes	
D424,028 S	5/2000	Vaiani	
D436,101 S	1/2001	McGovern et al.	
D437,243 S	2/2001	Cessac	
D440,890 S	4/2001	Warner et al.	
D442,947 S	5/2001	Warner et al.	
D453,329 S	2/2002	Muramatsu	
D455,735 S	4/2002	Winslow	
D457,518 S	5/2002	Wilson	
D462,070 S	8/2002	Wilson	
D462,675 S	9/2002	Kusz et al.	
D466,496 S	12/2002	McDonald et al.	
D467,242 S	12/2002	Warner et al.	
D468,731 S	1/2003	Wilson	
D486,146 S	2/2004	Dearnley	
D493,169 S	7/2004	Cheng	
D493,447 S	7/2004	Noro et al.	
D513,477 S	1/2006	Heftman	
D519,860 S	5/2006	Bugbee	

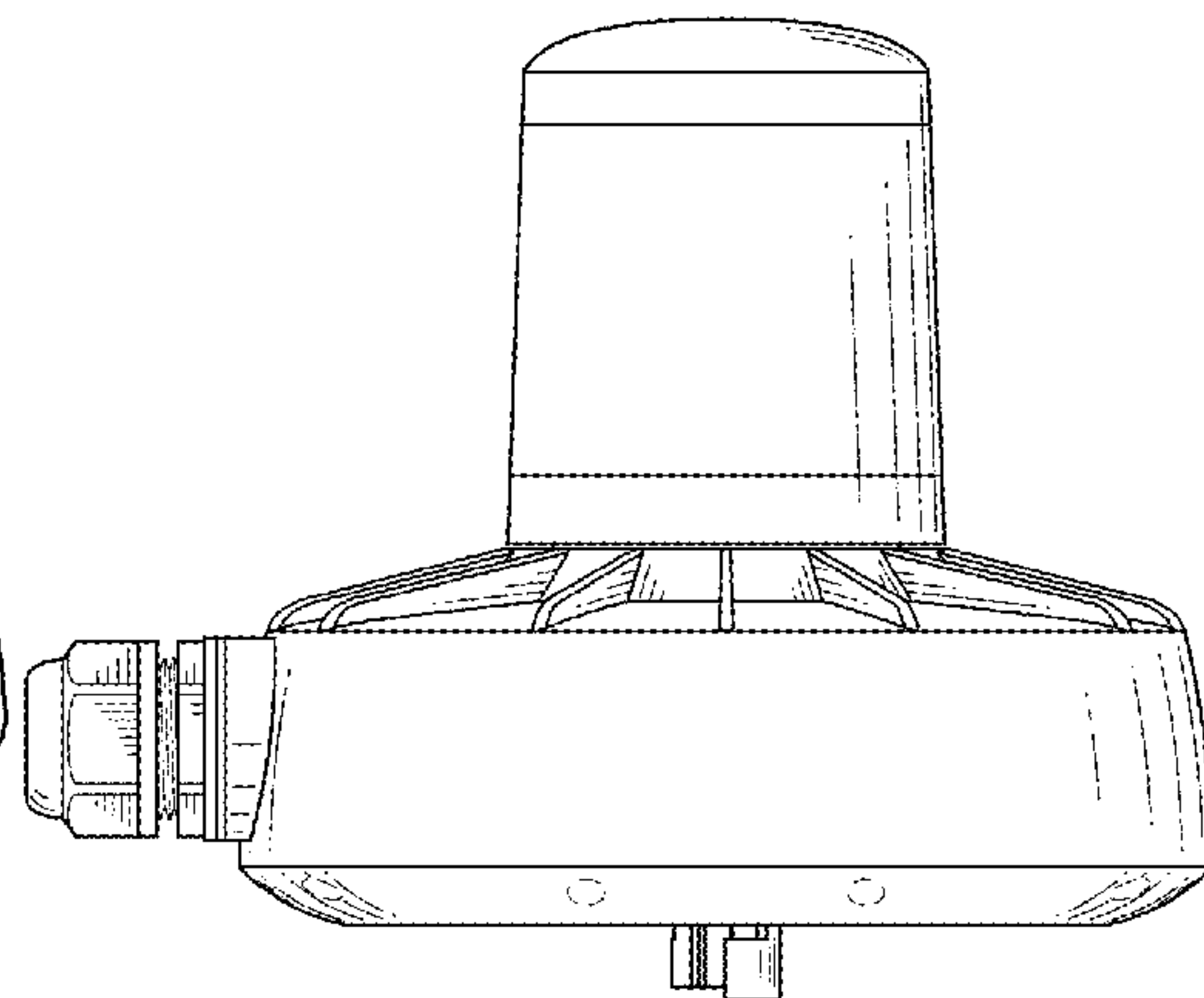
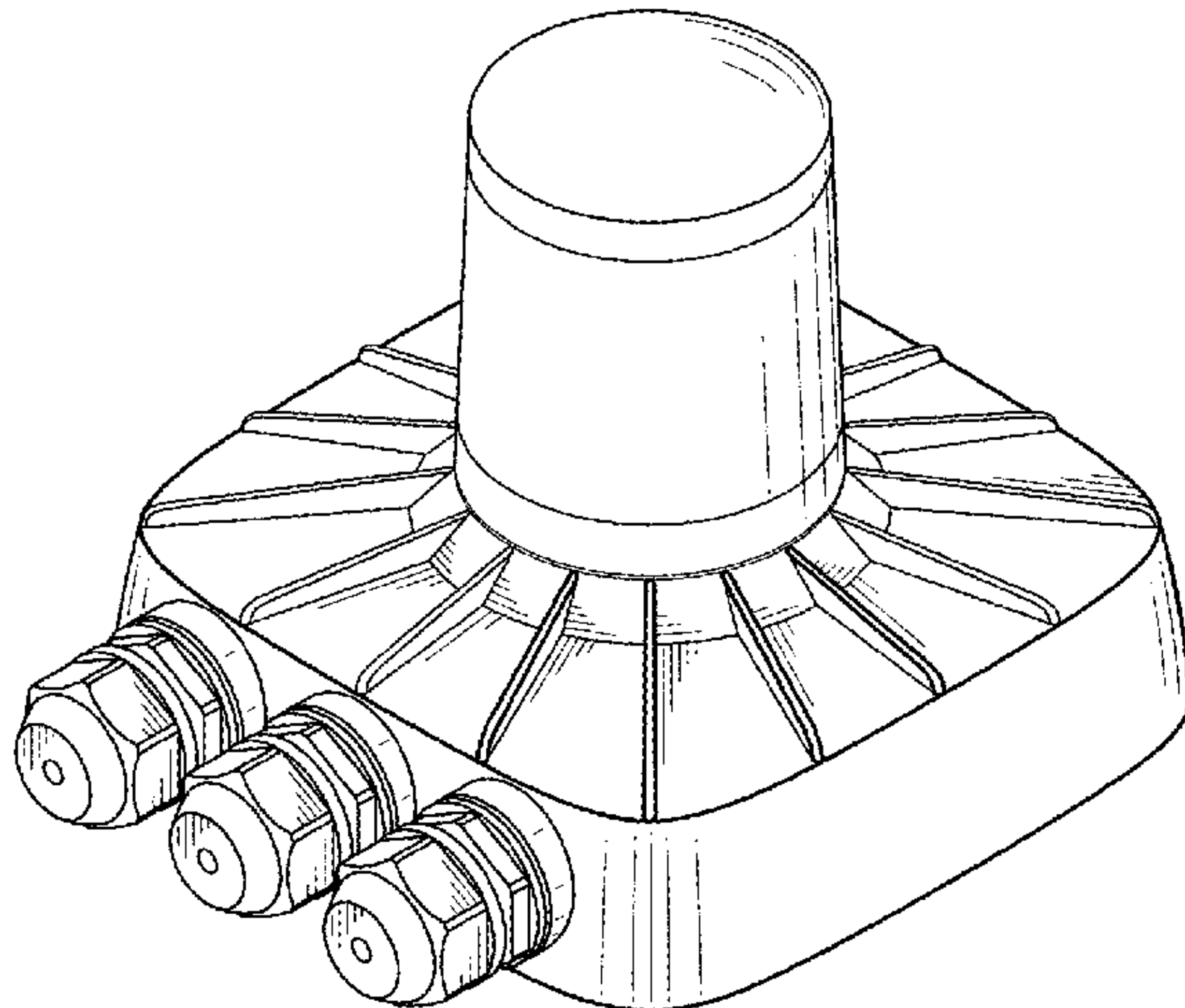

D525,231 S 7/2006 McMillen et al.
D531,626 S 11/2006 Agrawal et al.
D543,540 S 5/2007 Westerling et al.
D543,975 S 6/2007 McCown
D544,805 S 6/2007 Corrigan et al.
D550,659 S 9/2007 Noro
D557,260 S 12/2007 Westerling et al.
D560,533 S 1/2008 Dueker et al.
D566,698 S 4/2008 Choi et al.
D570,722 S 6/2008 Taylor
7,406,298 B2* 7/2008 Luglio H04B 1/38
340/500
D591,888 S 5/2009 Gill
D591,889 S 5/2009 Gill
D591,890 S 5/2009 Gill
D591,891 S 5/2009 Gill
D591,892 S 5/2009 Gill
D592,088 S 5/2009 Miller
D592,345 S 5/2009 Gill
D592,346 S 5/2009 Gill
D592,650 S 5/2009 Tsang et al.
D598,316 S 8/2009 Kuwano
D601,053 S 9/2009 Ferrie et al.
D604,279 S 11/2009 Chen et al.
D605,965 S 12/2009 Jackson
D608,232 S 1/2010 Duran Neira et al.
D608,673 S 1/2010 Arosio
D612,760 S 3/2010 Chen et al.
D616,777 S 6/2010 Jackson
D619,992 S 7/2010 Wayman
D621,812 S 8/2010 Wayman
D622,709 S 8/2010 Hem et al.
D623,633 S 9/2010 Bliss et al.
D624,448 S 9/2010 Jackson
D626,442 S 11/2010 Jackson
D627,911 S 11/2010 Mo et al.
D634,308 S 3/2011 Bliss et al.
D638,001 S 5/2011 Nakhjiri et al.
D641,647 S 7/2011 Wu
D647,812 S 11/2011 Kuwano et al.
D648,241 S 11/2011 Kuwano et al.
D650,115 S 12/2011 Kim et al.
D650,513 S 12/2011 Blincoe et al.
D651,110 S 12/2011 Kuwano
D651,111 S 12/2011 Kuwano
D651,112 S 12/2011 Kuwano
D651,113 S 12/2011 Kuwano et al.
D652,334 S 1/2012 Kuwano et al.
D666,583 S 9/2012 Le et al.
D668,981 S 10/2012 Hsiao
D668,982 S 10/2012 Hsiao
D674,787 S 1/2013 Tsuda et al.
D674,788 S 1/2013 Tsuda et al.
D680,893 S 4/2013 Adams
D684,078 S 6/2013 Clifford et al.
D690,450 S 9/2013 Guercio et al.
D694,740 S 12/2013 Apostolakis
D696,642 S 12/2013 Jia et al.
D701,466 S 3/2014 Clifford et al.
D706,152 S 6/2014 Ni et al.
D709,782 S 7/2014 Stuffle
D713,092 S 9/2014 Smith et al.
D713,816 S 9/2014 Fleetwood et al.
D720,247 S 12/2014 Covelli et al.
D729,214 S 5/2015 Beaudoin
D730,333 S 5/2015 Matsumoto
D733,107 S 6/2015 Porter
D744,985 S 12/2015 Schulz et al.
D744,986 S 12/2015 Huerta et al.
D749,974 S 2/2016 Hoßbach et al.
D751,534 S 3/2016 Lenz et al.
D757,588 S 5/2016 Stuffle
9,362,629 B2 6/2016 Hinman et al.
D772,206 S 11/2016 Lasier et al.
D772,850 S 11/2016 Söfström
D789,360 S 6/2017 Moon et al.
D790,514 S 6/2017 Woodward et al.
D791,109 S 7/2017 Wallace et al.
D794,635 S 8/2017 Nimre

D806,691 S 1/2018 Andersson
9,930,668 B2 3/2018 Barzegar et al.
D814,450 S 4/2018 Kumazawa et al.
D817,914 S 5/2018 Britz et al.
D823,839 S 7/2018 Emery
D829,696 S 10/2018 Wallace et al.
D833,312 S 11/2018 Alonso
D844,581 S 4/2019 Zhou
10,312,650 B2* 6/2019 Siacotos H01R 33/96
D856,962 S * 8/2019 Hart D14/155
D867,319 S * 11/2019 Aaron D14/140.6
D867,320 S * 11/2019 Aaron D14/140.6
D867,321 S * 11/2019 Zimmerman, III D14/140.6
D868,015 S * 11/2019 Zimmerman, III D14/140.6
D868,016 S * 11/2019 Zimmerman, III D14/140.6
D868,017 S * 11/2019 Aaron D14/140.6
D868,722 S * 12/2019 Zimmerman, III D14/140.6
D871,361 S * 12/2019 Aaron D14/140.6
D875,705 S * 2/2020 Zimmerman, III D14/140.6
2014/0155054 A1 6/2014 Henry et al.
2015/0124100 A1 5/2015 McRory
2018/0045388 A1 2/2018 McDowell et al.
2018/0172229 A1 6/2018 Lockwood et al.
2018/0172243 A1 6/2018 Clynne et al.
2018/0279445 A1 9/2018 Harwood
2018/0292056 A1 11/2018 Kim
2018/0323503 A1 11/2018 Bouchard
2020/0088390 A1* 3/2020 Stegeman F21S 8/086

OTHER PUBLICATIONS

Mucci, "Top 3 wireless infrastructure service company trends," RCR Wireless News, Sep. 10, 2015. Retrieved on Oct. 23, 2019 from <https://www.rerwireless.com/20150910/workforce/top-3-wireless-infrastructure-service-company-trends-inside-telecom-careers-episode-12-tag1>.
"Smart Lighting—Ubicell" Ubicquia, Retrieved Jun. 14, 2019 from http://www.ubicquia.com/wp-content/uploads/2019/01/word_press_product_ubicell.png.
"Smart Connectivity—Ubicell" Ubicquia retrieved on Jun. 14, 2019 from http://www.ubicquia.com/wp-content/upioads/2019/01/_/word_press_product_ubihub.png.
"UbicellL-ubihub—ubimetro" Facebook, Uploaded Feb. 26, 2018. retrieved on Jun. 14, 2019 <https://www.facebook.com/ubicquia/photos/a.367486246971918/542412166145991/?type=3&theater>.

* cited by examiner

Primary Examiner — Marie D. Fast Horse
(74) Attorney, Agent, or Firm — Seed IP Law Group LLP

(57) CLAIM

The ornamental design for a wireless networking cell for mounting on an aerial lighting fixture, as shown and described.

DESCRIPTION

FIG. 1 is a perspective view of a wireless networking cell for mounting on an aerial lighting fixture showing a first embodiment of our new design.
FIG. 2 is a top plan view thereof.
FIG. 3 is a bottom plan view thereof.
FIG. 4 is an enlarged scale partial cross-sectional view thereof taken along line 4-4 of FIG. 3.
FIG. 5 is a front elevational view thereof.
FIG. 6 is a rear elevational view thereof.
FIG. 7 is a left side elevational view thereof.
FIG. 8 is a right side elevational view thereof.

FIG. **9** is a perspective view of a wireless networking cell for mounting on an aerial lighting fixture showing a second embodiment of our new design.

FIG. **10** is a top plan view thereof.

FIG. **11** is a bottom plan view thereof.

FIG. **12** is an enlarged scale partial cross-sectional view thereof taken along line **12-12** of FIG. **11**.

FIG. **13** is a front elevational view thereof.

FIG. **14** is a rear elevational view thereof.

FIG. **15** is a left side elevational view thereof; and,

FIG. **16** is a right side elevational view thereof.

The dot-dash broken lines in FIGS. **3** and **11** define the boundary of the claim, which extends to the boundary but does not include the boundary; while all other broken lines depict portions of the wireless networking cell for mounting on an aerial lighting fixture that form no part of the claimed design.

1 Claim, 8 Drawing Sheets

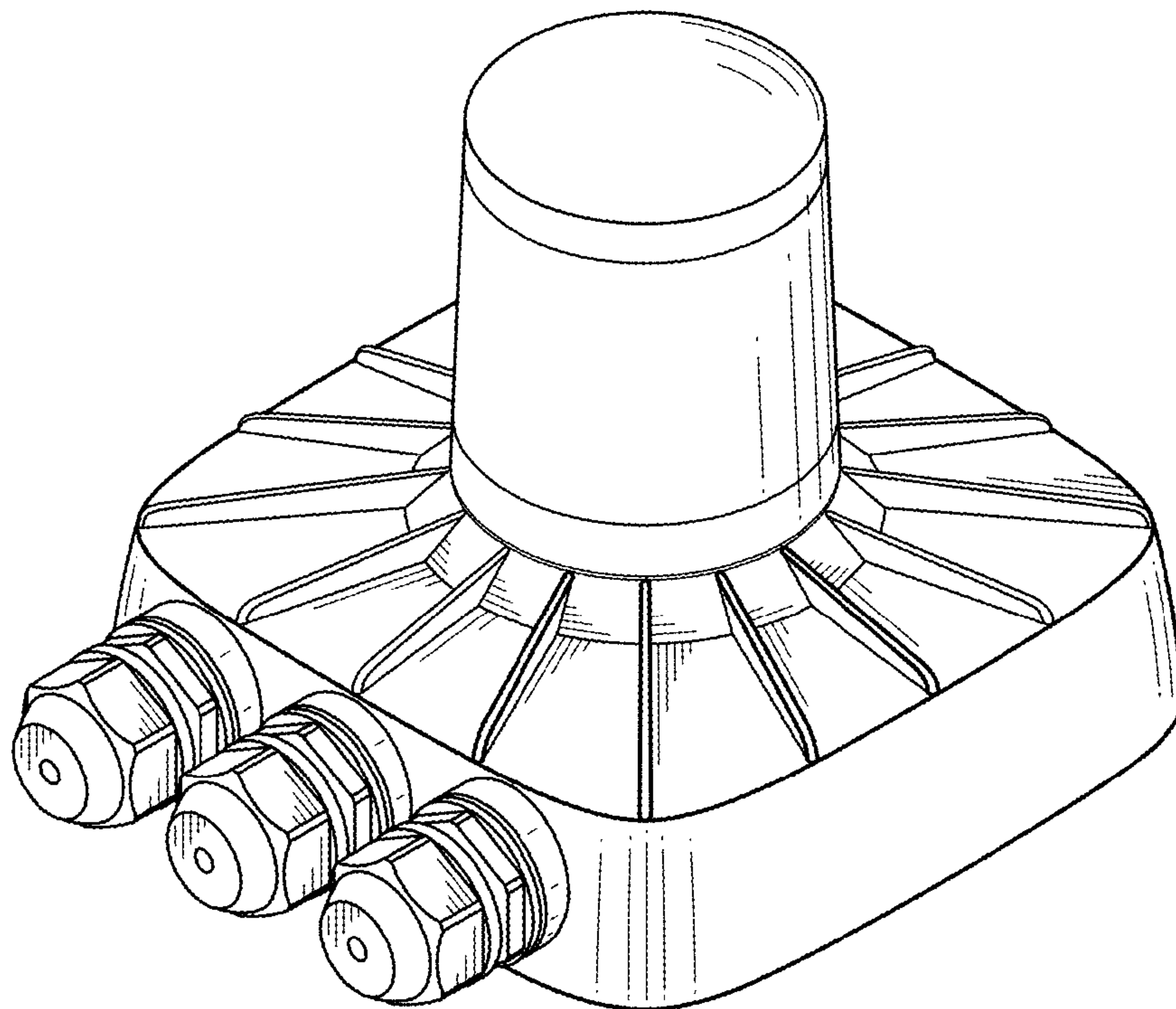

FIG. 1

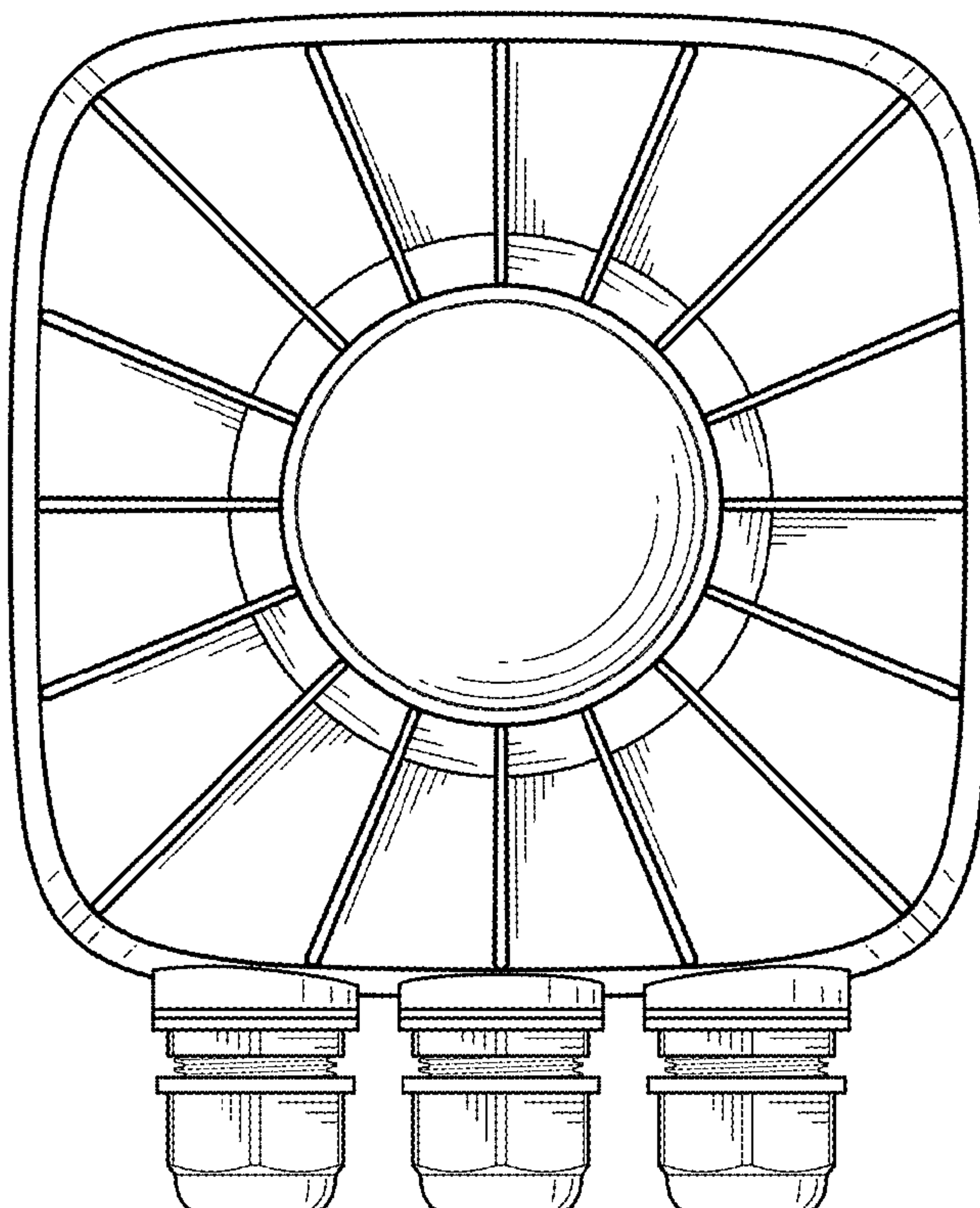

FIG. 2

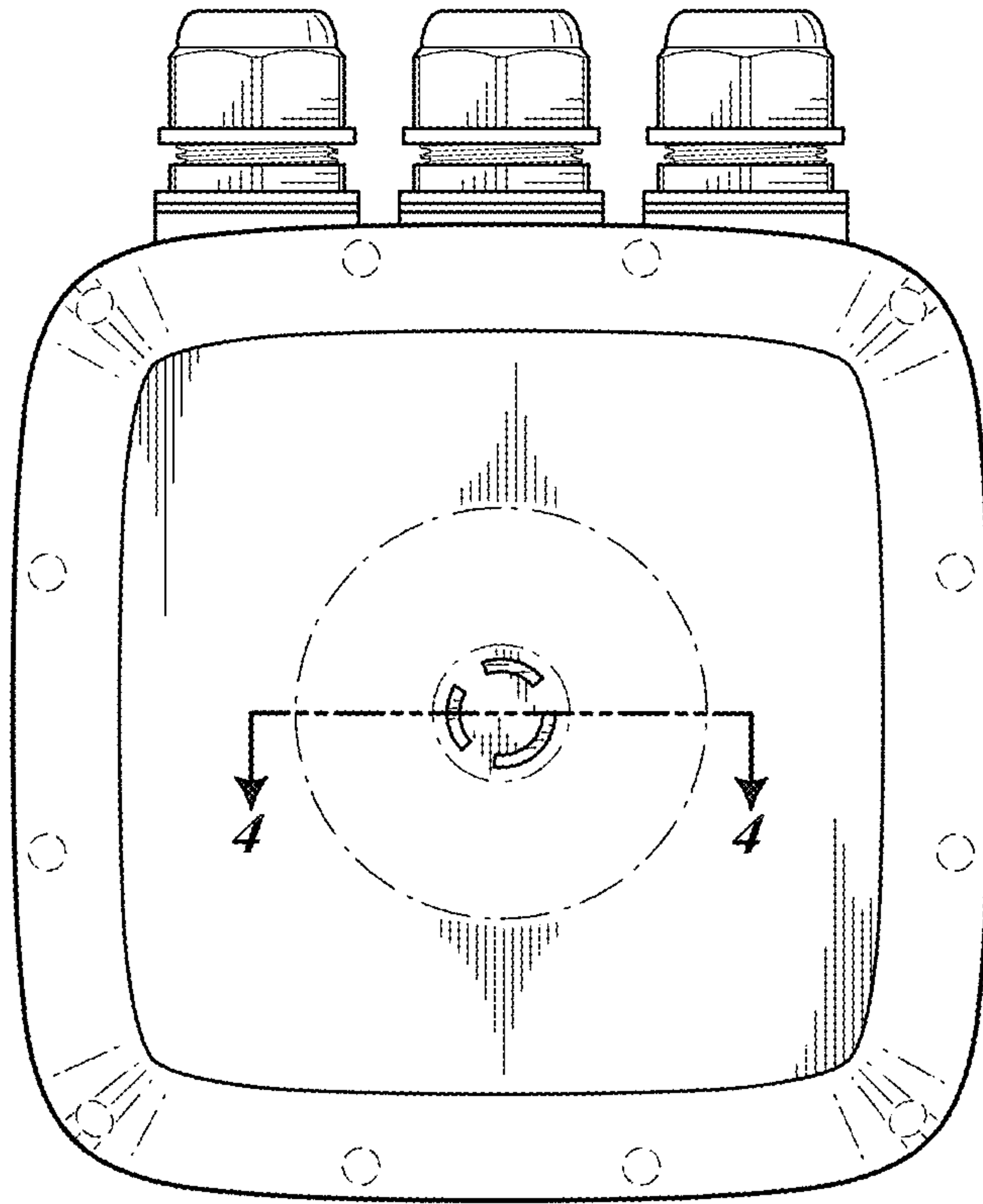

FIG. 3

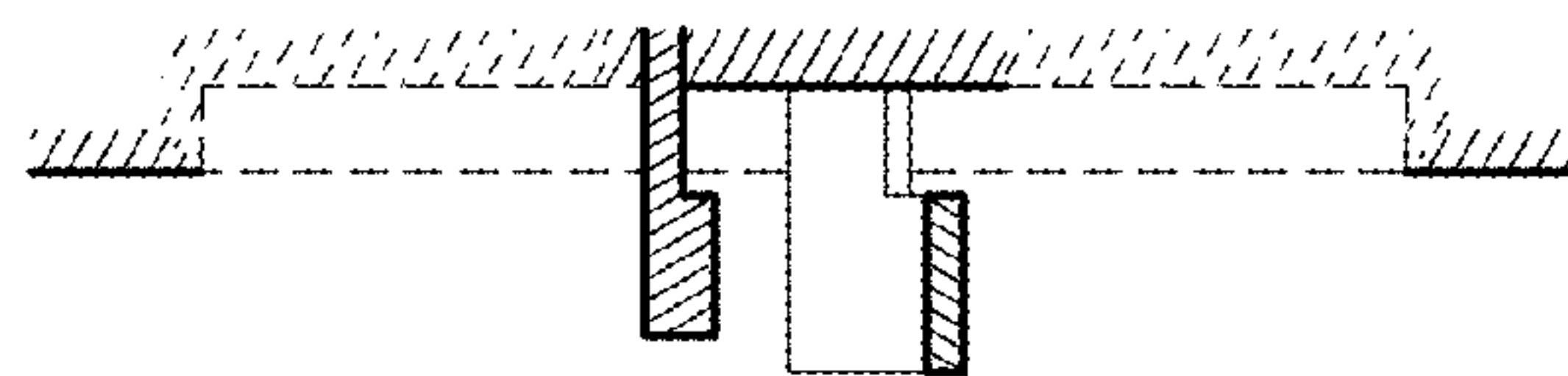

FIG. 4

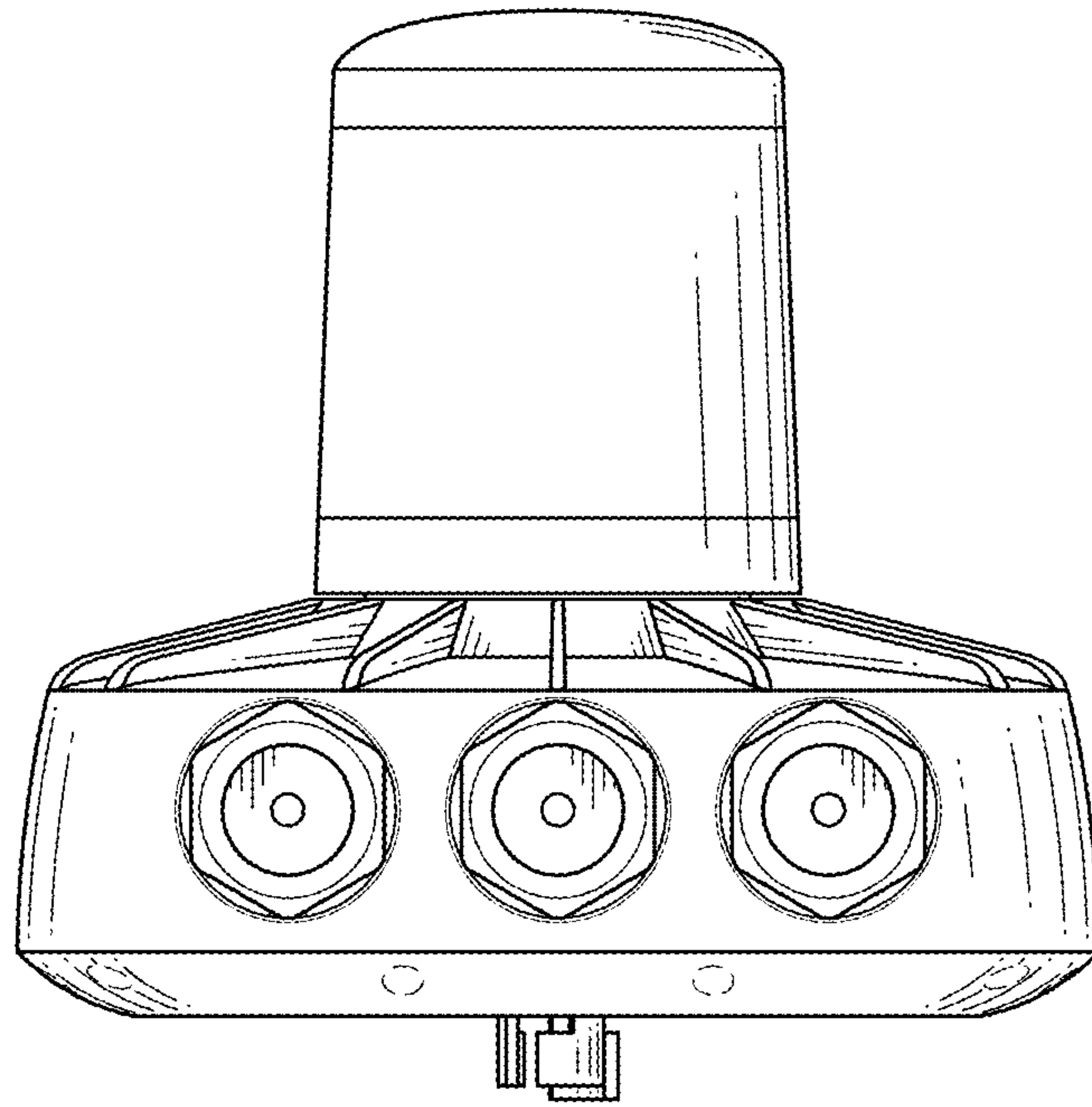

FIG. 5

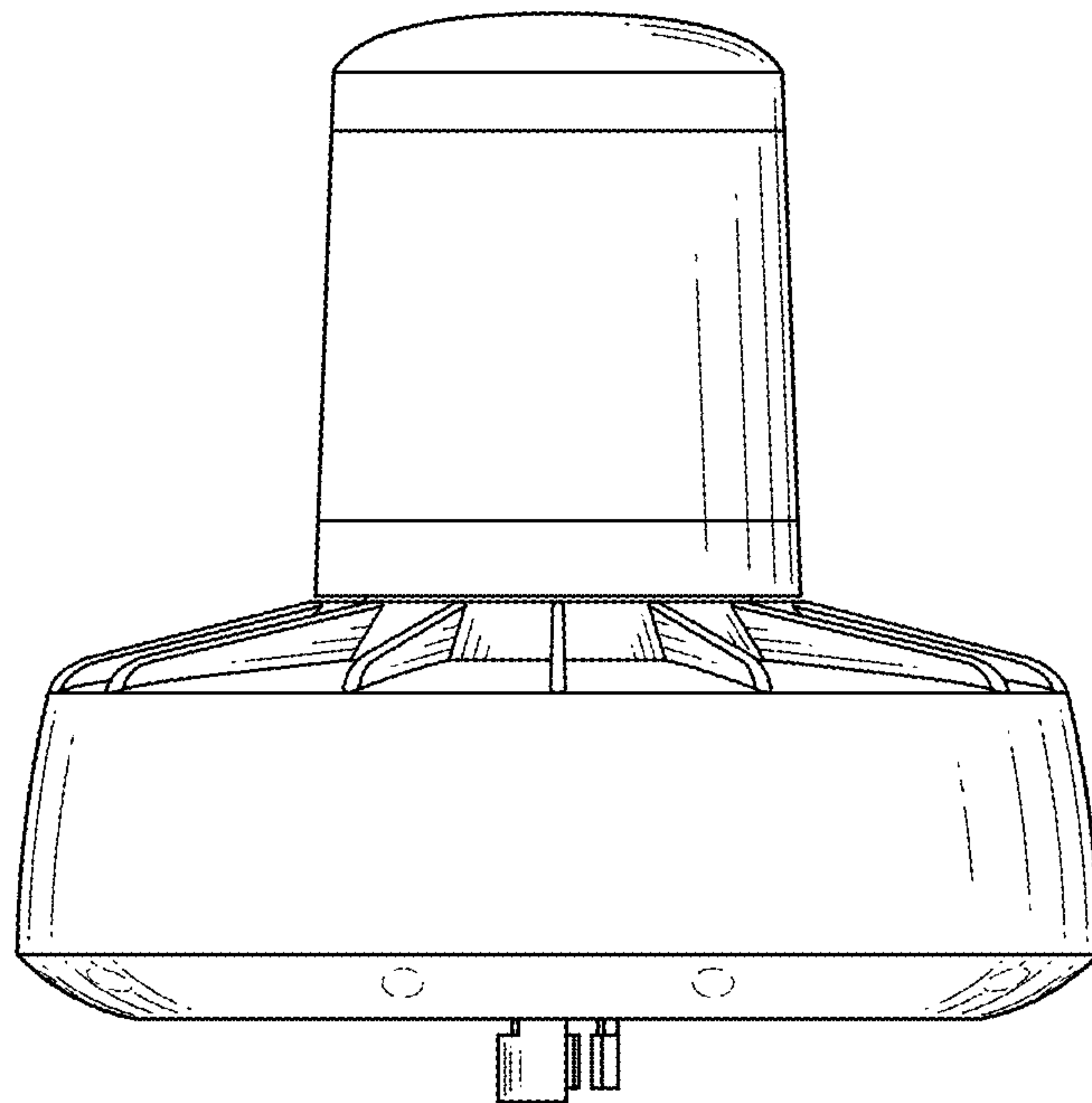

FIG. 6

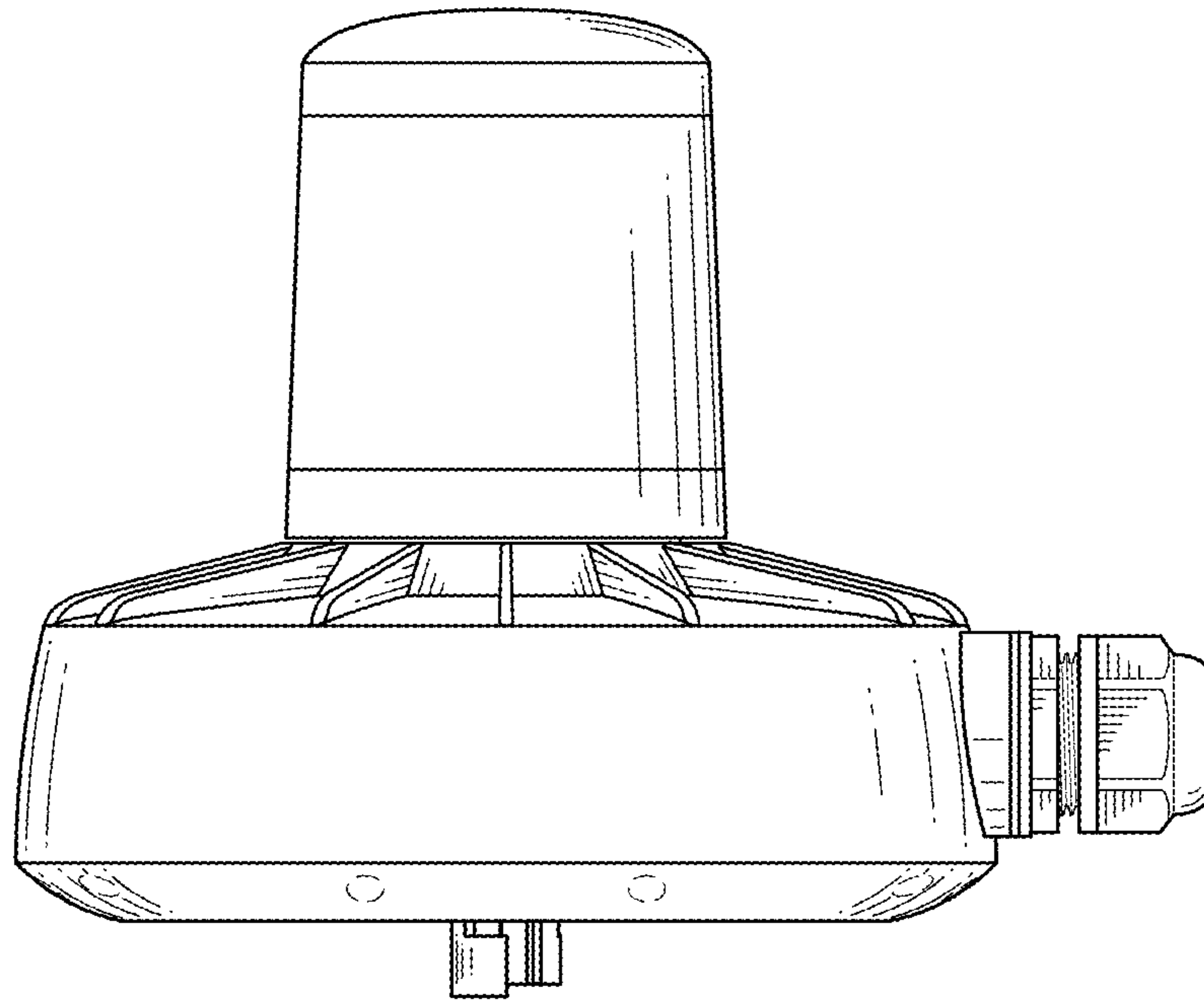

FIG. 7

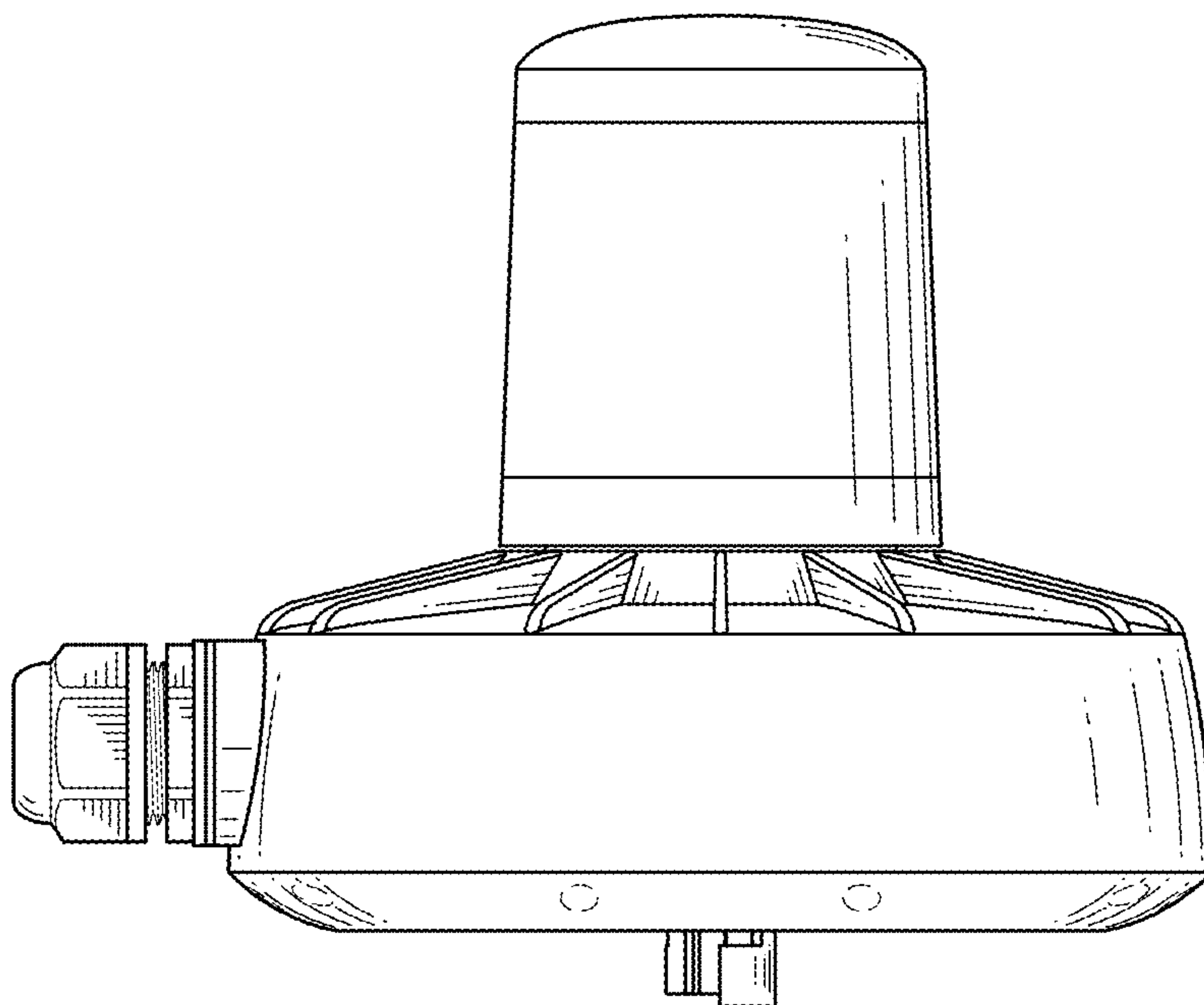

FIG. 8

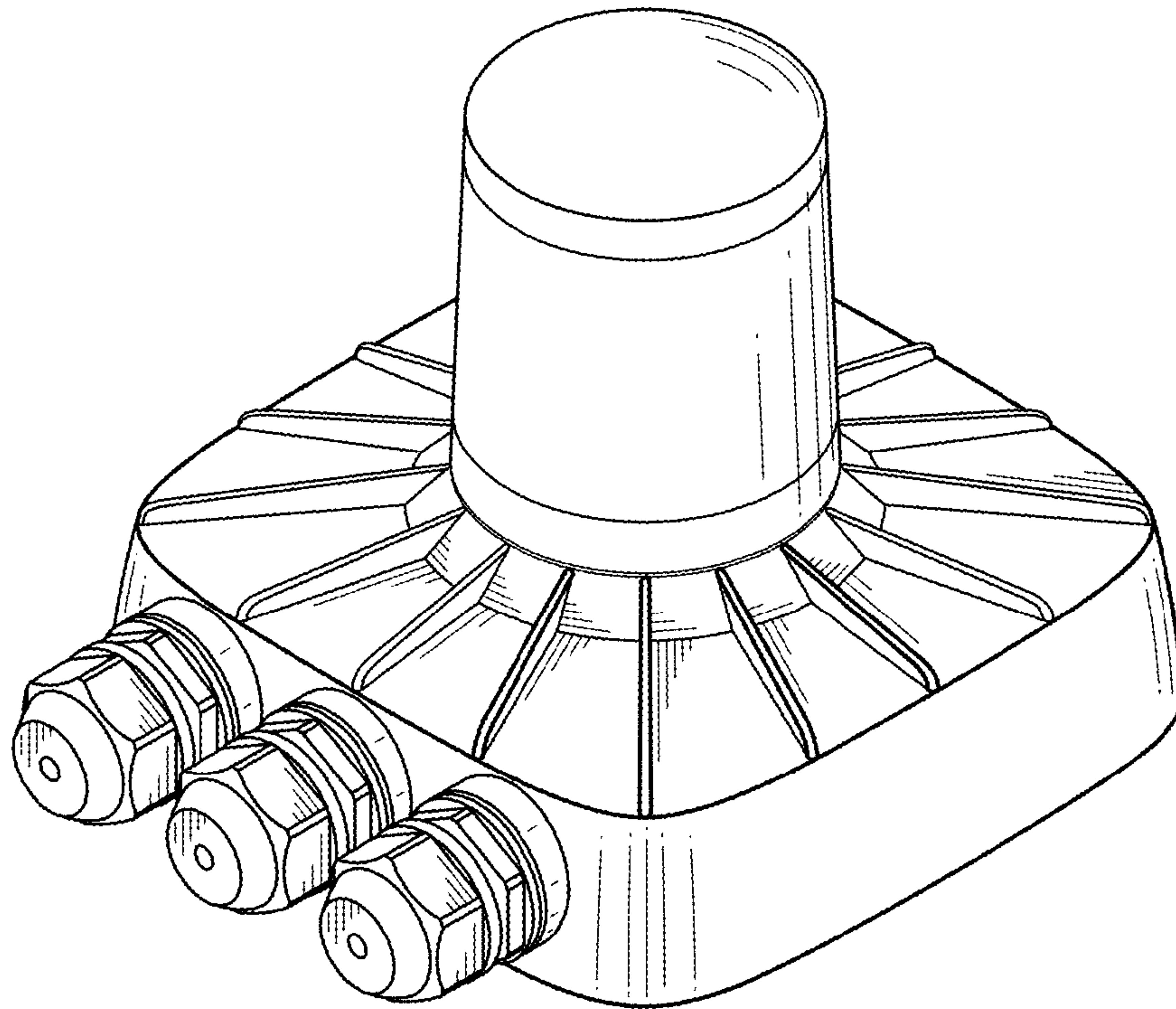

FIG. 9

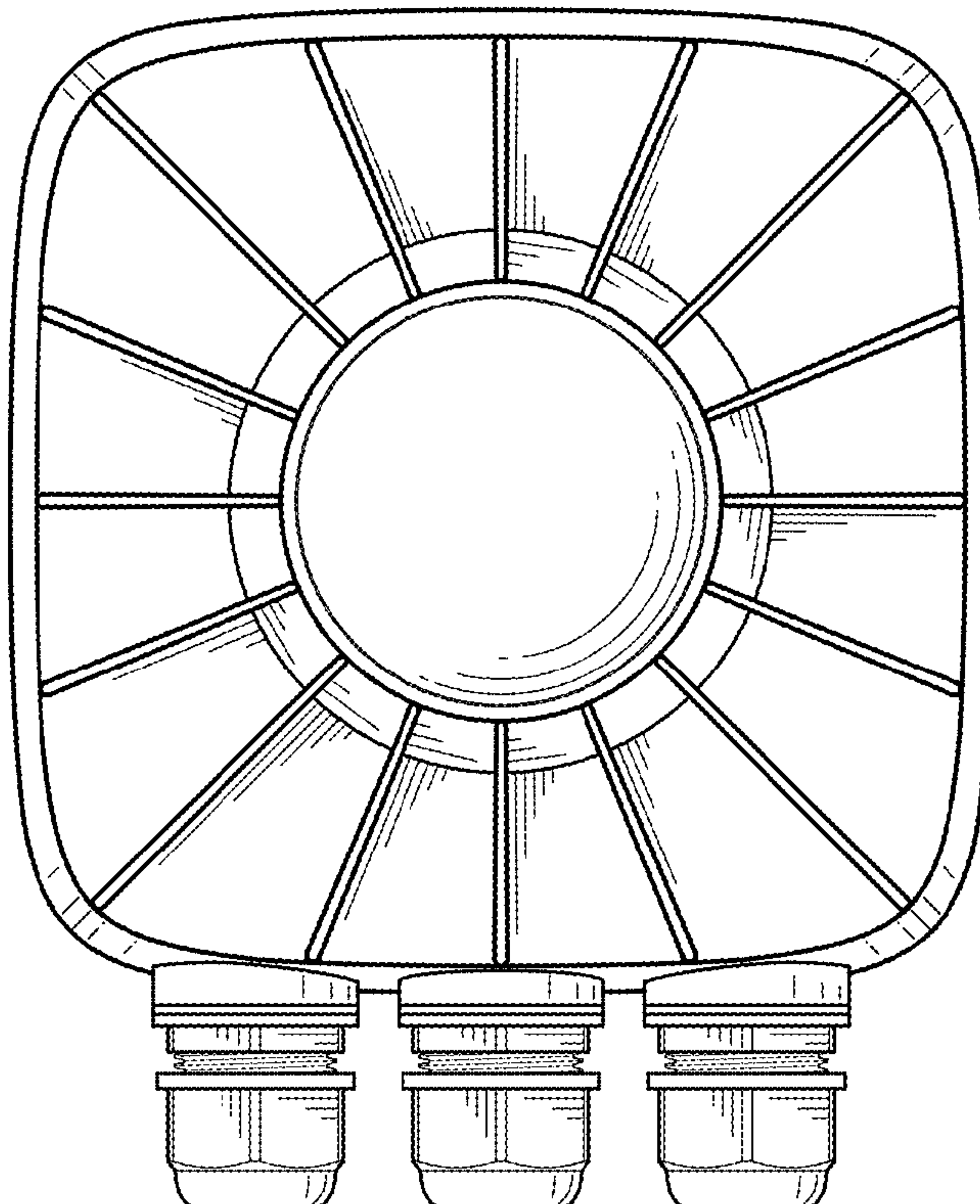

FIG. 10

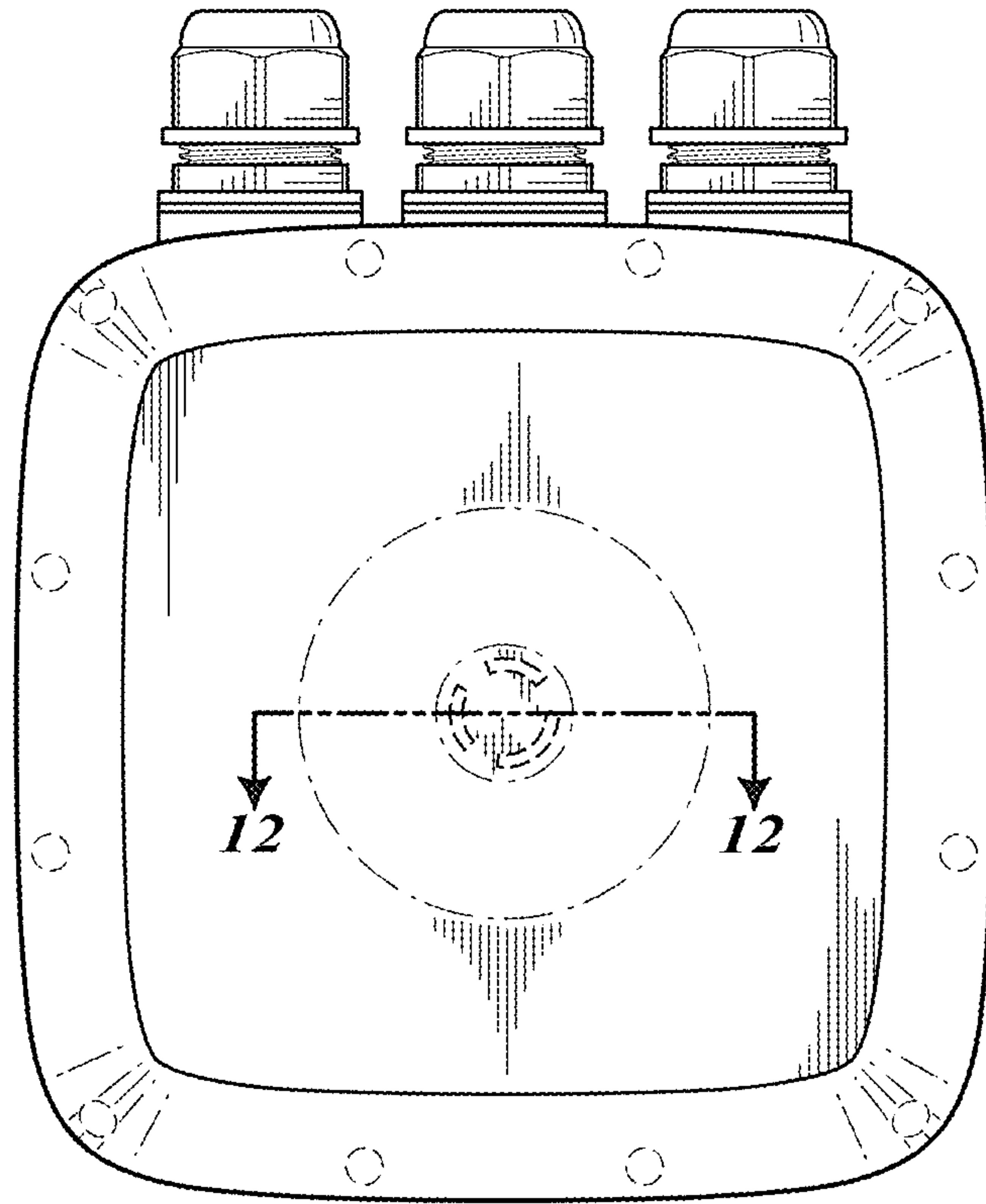

FIG. 11

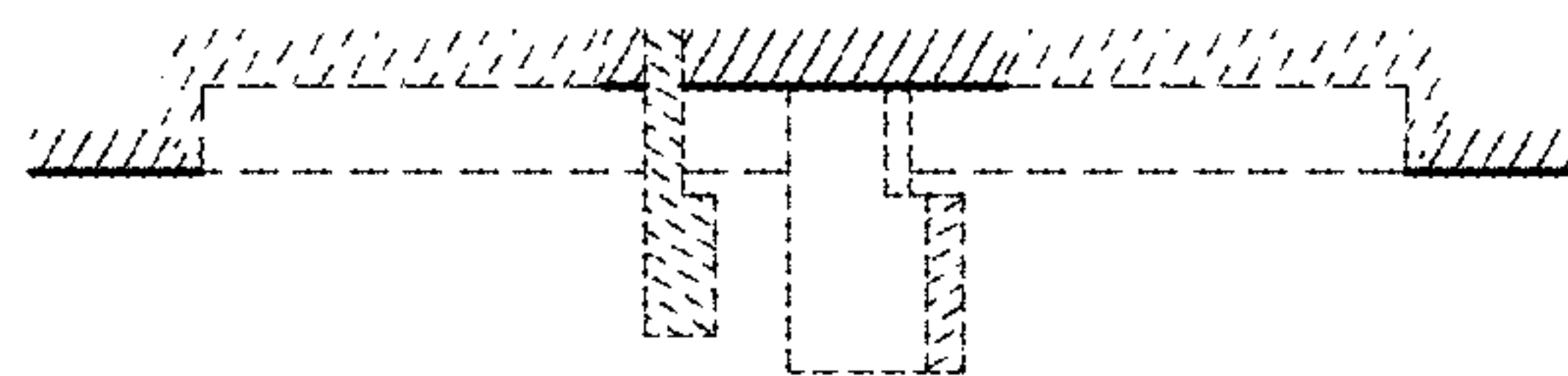

FIG. 12

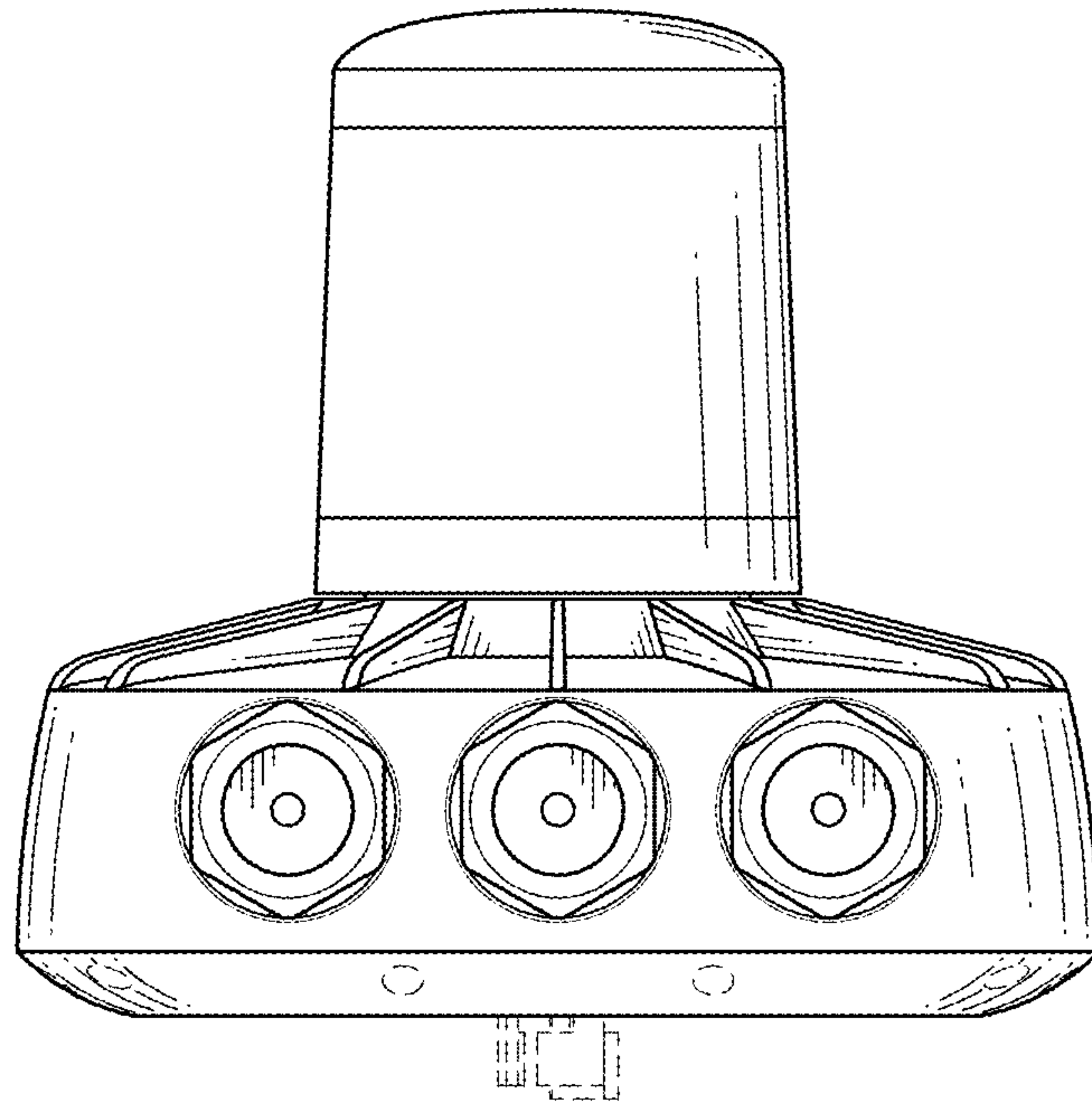

FIG. 13

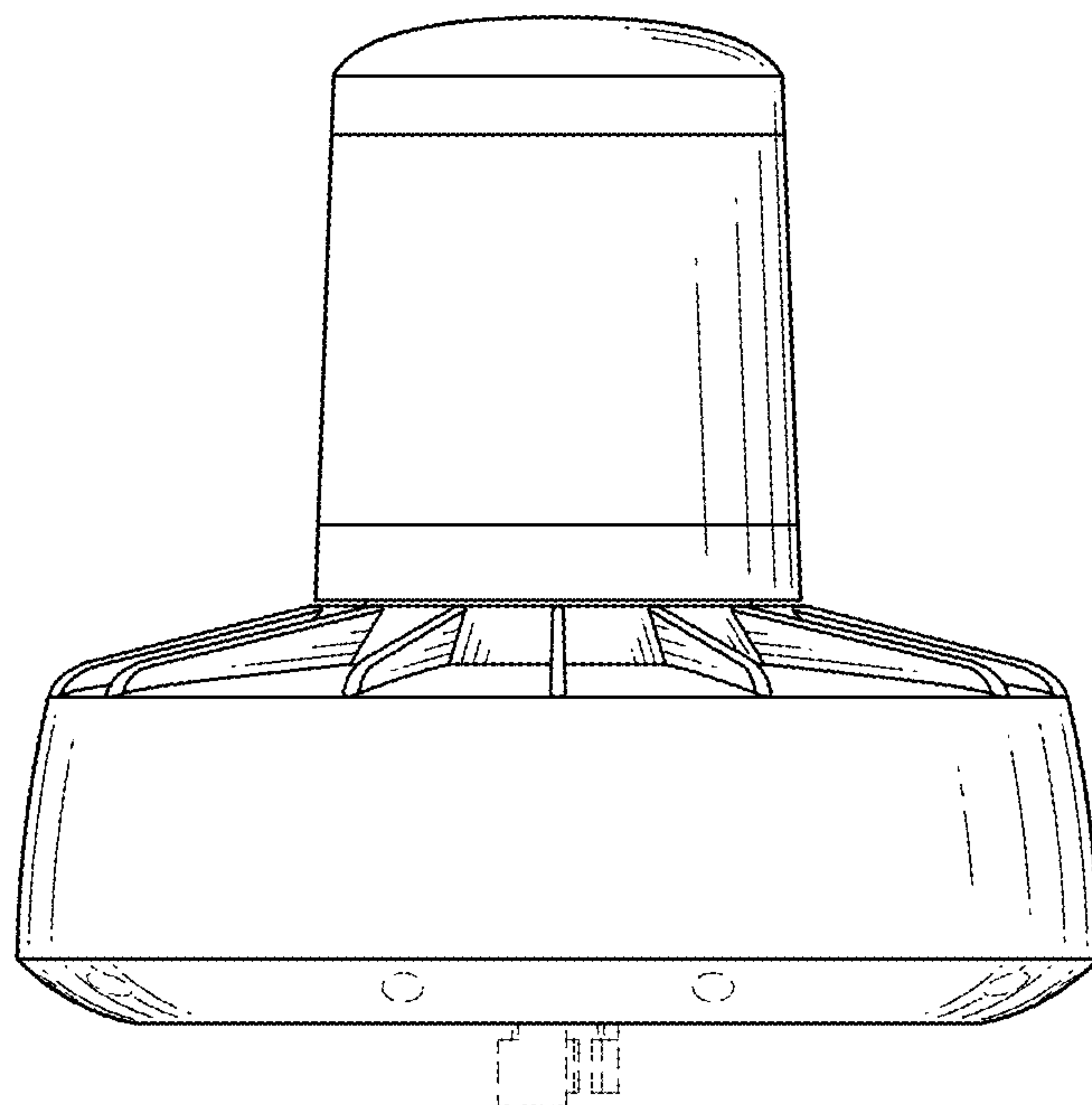

FIG. 14

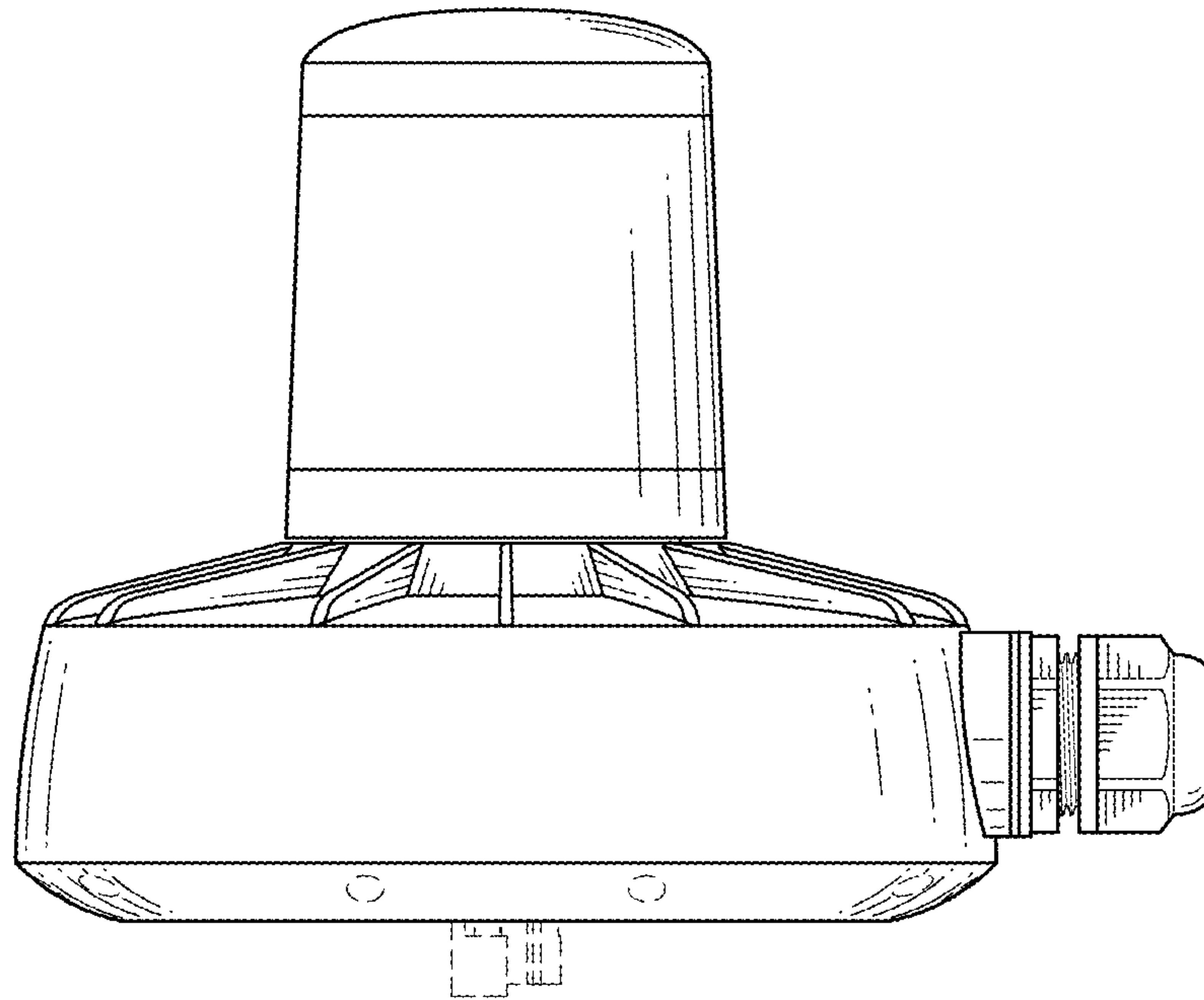

FIG. 15

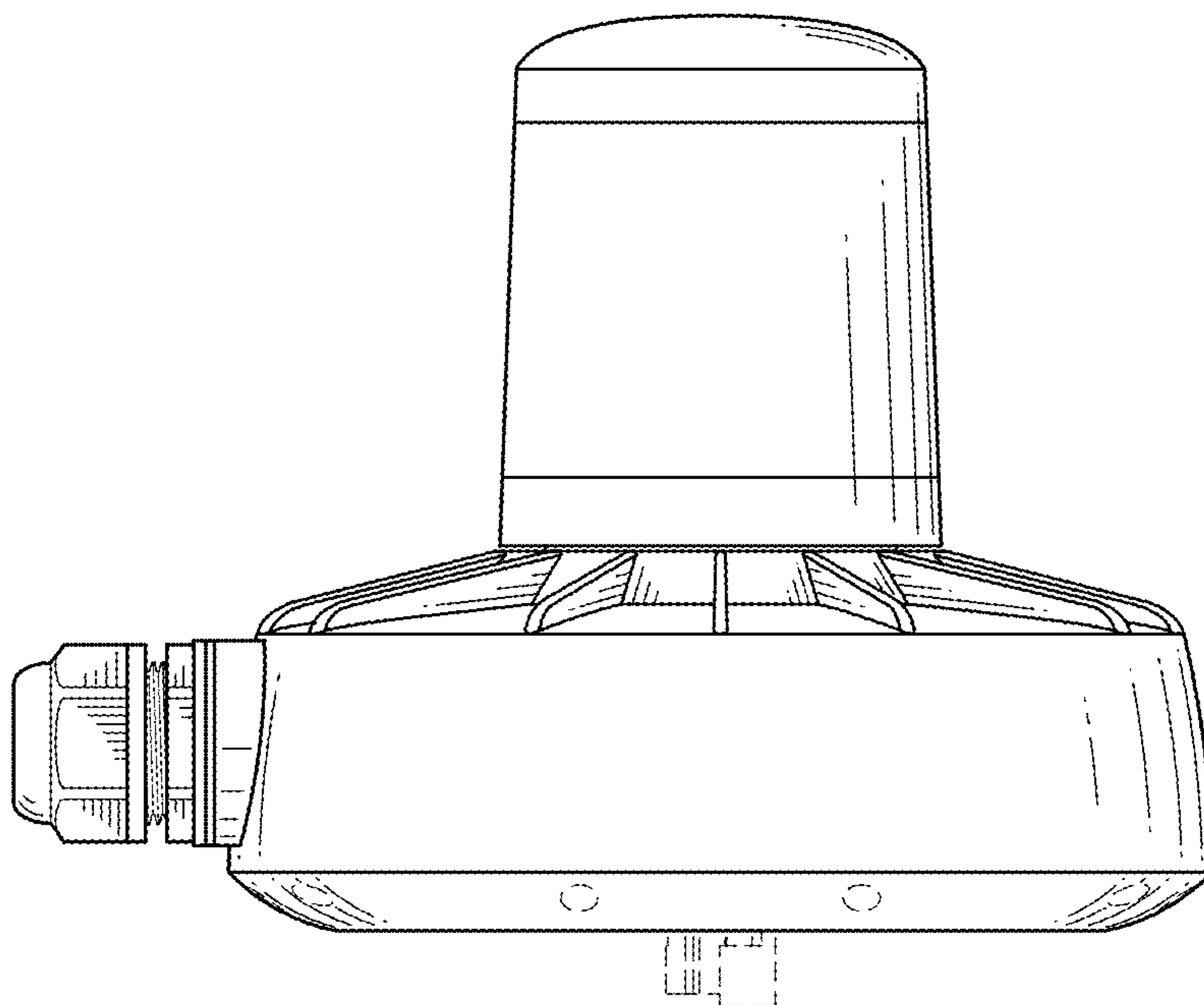

FIG. 16