



US00D892701S

(12) **United States Design Patent**
Cox et al.

(10) **Patent No.:** **US D892,701 S**

(45) **Date of Patent:** **** Aug. 11, 2020**

(54) **VEHICLE WHEEL**

(71) Applicant: **MF IP Holding, LLC**, West Jordan, UT (US)

(72) Inventors: **Christopher Paul Cox**, West Jordan, UT (US); **Sean J. Kleinschuster**, Menifee, CA (US)

(73) Assignee: **MF IP Holding, LLC**, West Jordan, UT (US)

(**) Term: **15 Years**

(21) Appl. No.: **29/689,098**

(22) Filed: **Apr. 26, 2019**

(51) **LOC (12) Cl.** **12-16**

(52) **U.S. Cl.**
USPC **D12/209**

(58) **Field of Classification Search**
USPC D12/204–213; D21/563
CPC B60B 7/00; B60B 7/02; B60B 7/04; B60B 7/01; B60B 7/06; B60B 3/02; B60B 3/04; B60B 3/06; B60B 3/10; B60B 1/00; B60B 1/08; B60B 1/10; B60B 1/12
See application file for complete search history.

(56) **References Cited**

U.S. PATENT DOCUMENTS

D391,216 S *	2/1998	Bollmann	D12/209
D455,692 S *	4/2002	Iguchi	D12/209
D465,184 S *	11/2002	Chung	D12/211
D470,812 S *	2/2003	Chu	D12/211
D498,195 S *	11/2004	Guevara	D12/211
D522,429 S *	6/2006	Ishiwata	D12/209
D578,458 S *	10/2008	Cortes	D12/211
D579,848 S *	11/2008	Kim	D12/211
D620,421 S *	7/2010	Lamm	D12/209

D624,863 S *	10/2010	Zhao	D12/211
D668,195 S *	10/2012	Tant	D12/209
D678,159 S *	3/2013	Hale, Jr.	D12/209
D686,959 S *	7/2013	Hale	D12/209
D688,187 S *	8/2013	McMath	D12/209
D734,702 S *	7/2015	Hale	D12/209
D748,029 S *	1/2016	Kermelk	D12/209
D782,950 S *	4/2017	Hatton	D12/209
D800,628 S *	10/2017	Tran	D12/209
D802,509 S *	11/2017	Tran	D12/209
D817,844 S *	5/2018	Hale, Jr.	D12/209
D849,653 S *	5/2019	Chung	D12/209
D852,111 S *	6/2019	Kong	D12/211
D853,933 S *	7/2019	Henderson	D12/211
D856,245 S *	8/2019	Hale, Jr.	D12/209
D856,892 S *	8/2019	Zhao	D12/209
D865,625 S *	11/2019	Chiu	D12/209

* cited by examiner

Primary Examiner — Stacia A Cadmus

(74) *Attorney, Agent, or Firm* — Christensen O'Connor Johnson Kindness PLLC

(57) **CLAIM**

The ornamental design for the vehicle wheel, as shown and described.

DESCRIPTION

FIG. 1 is a perspective view of a vehicle wheel, showing our new design;
FIG. 2 is a front view thereof;
FIG. 3 is a top plan view thereof;
FIG. 4 is a perspective view of a second embodiment of a vehicle wheel, showing our new design;
FIG. 5 is a front view of FIG. 4; and,
FIG. 6 is a top plan view of FIG. 4.
The broken lines show portions of the vehicle wheel which form no part of the claimed design.

1 Claim, 6 Drawing Sheets

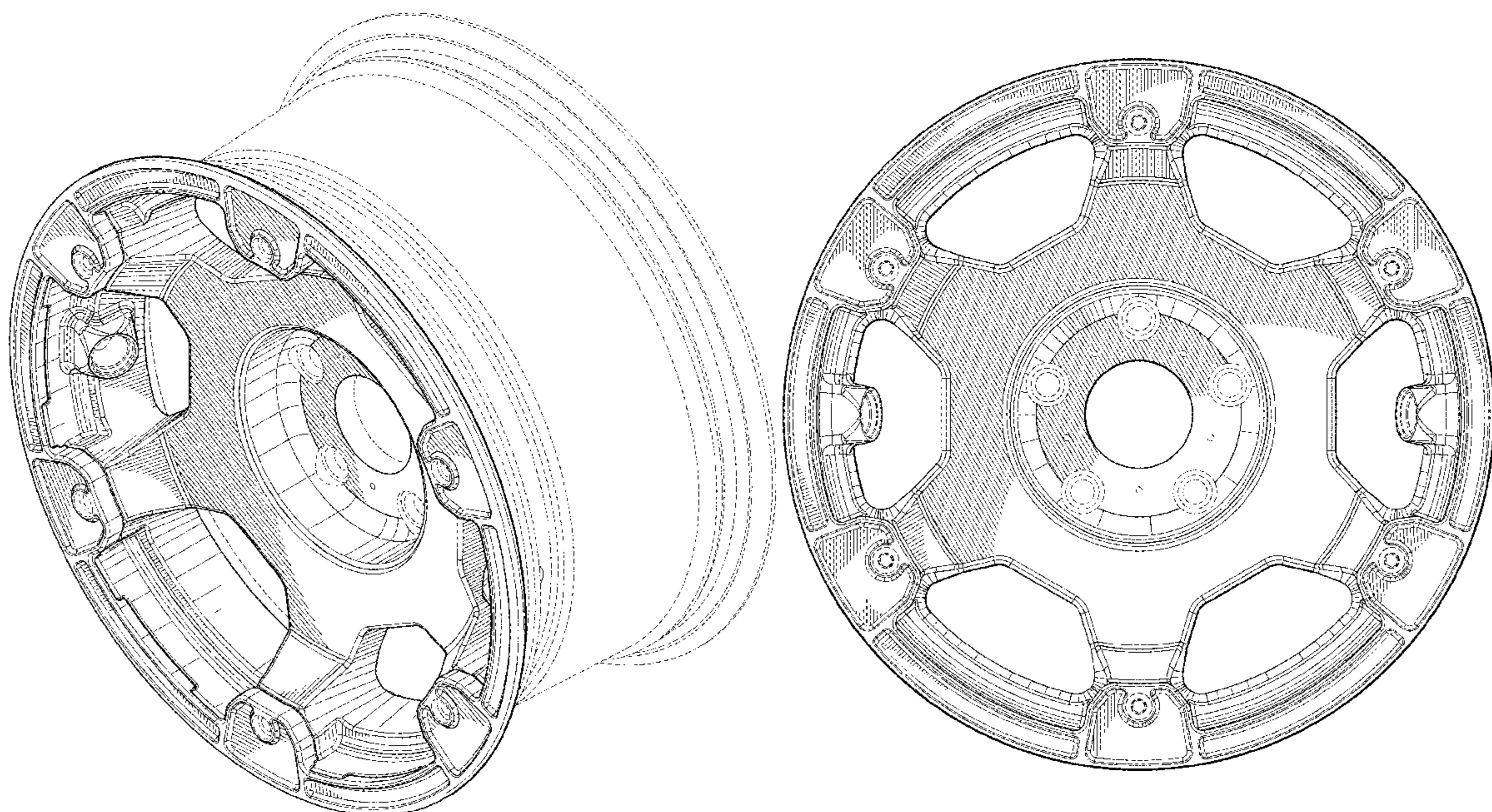

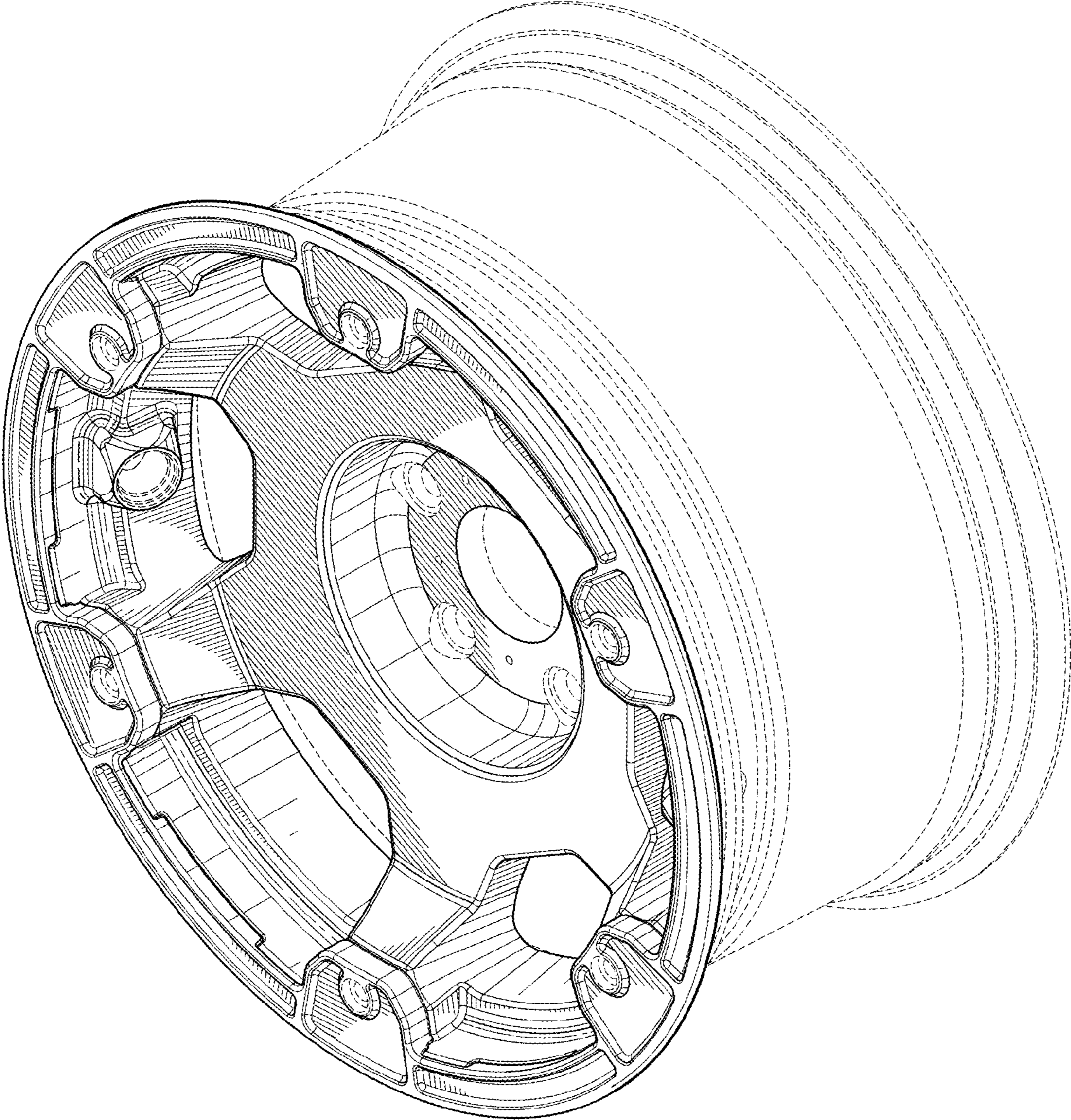

Fig. 1

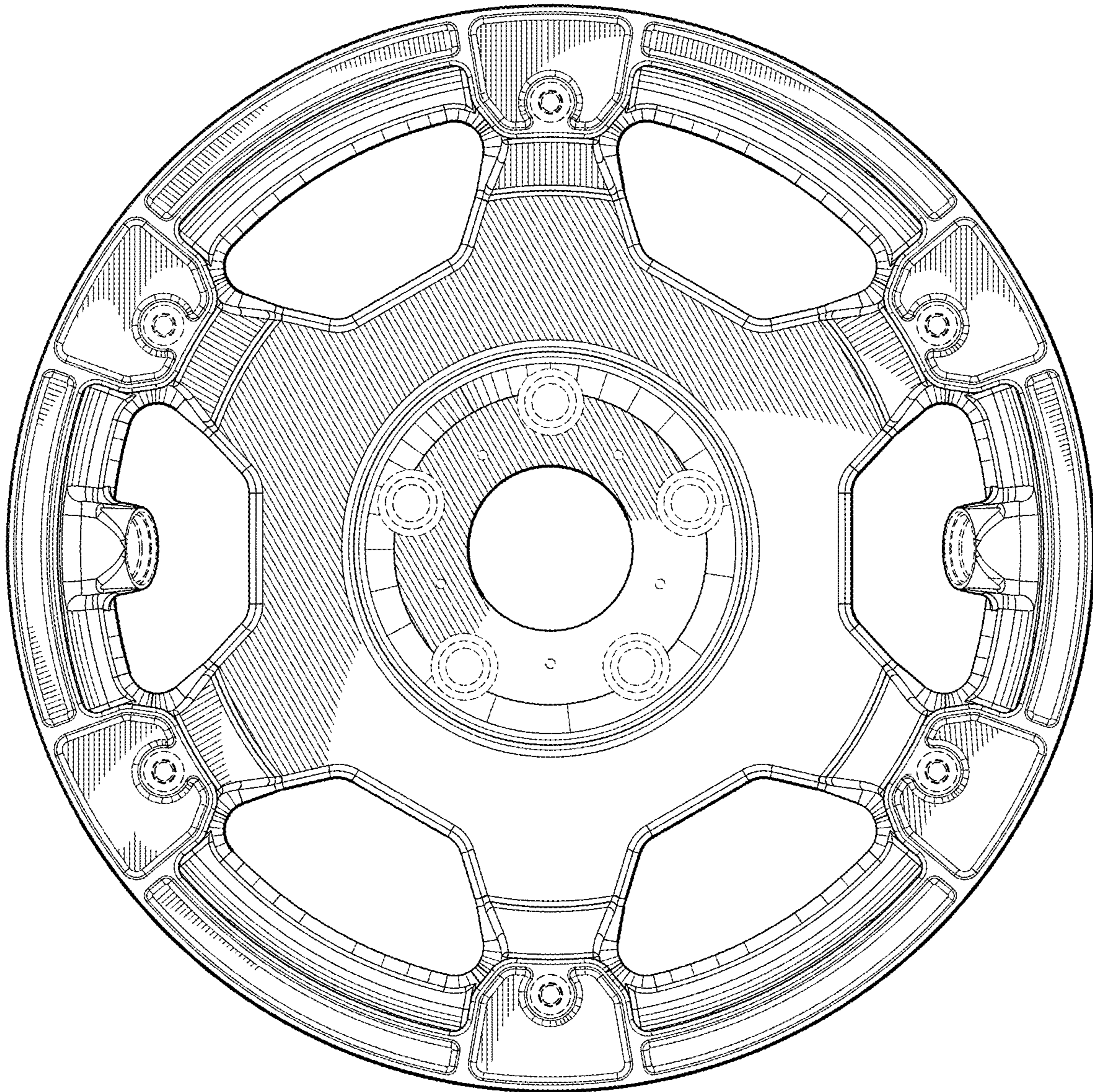

Fig. 2

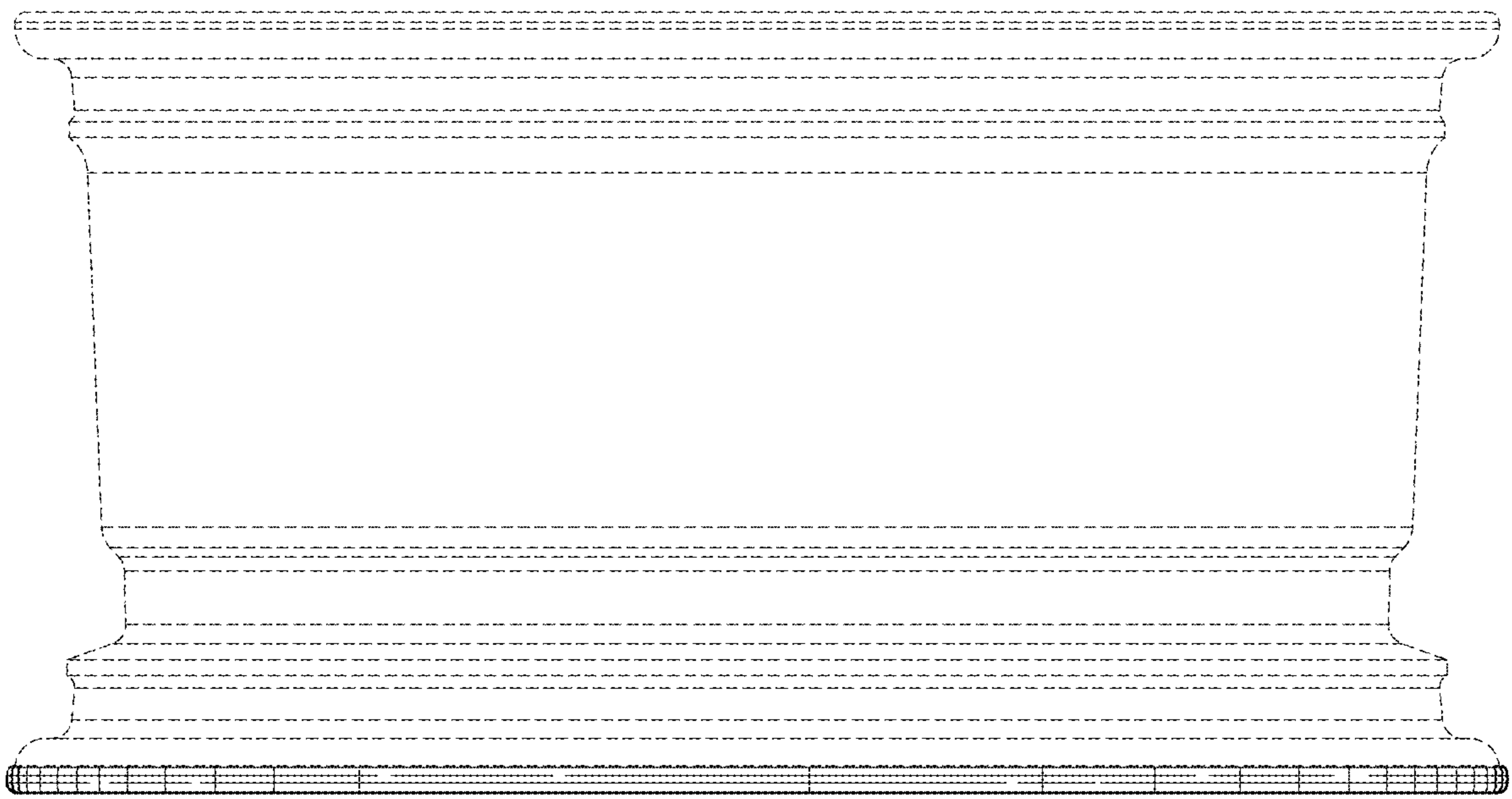

Fig. 3

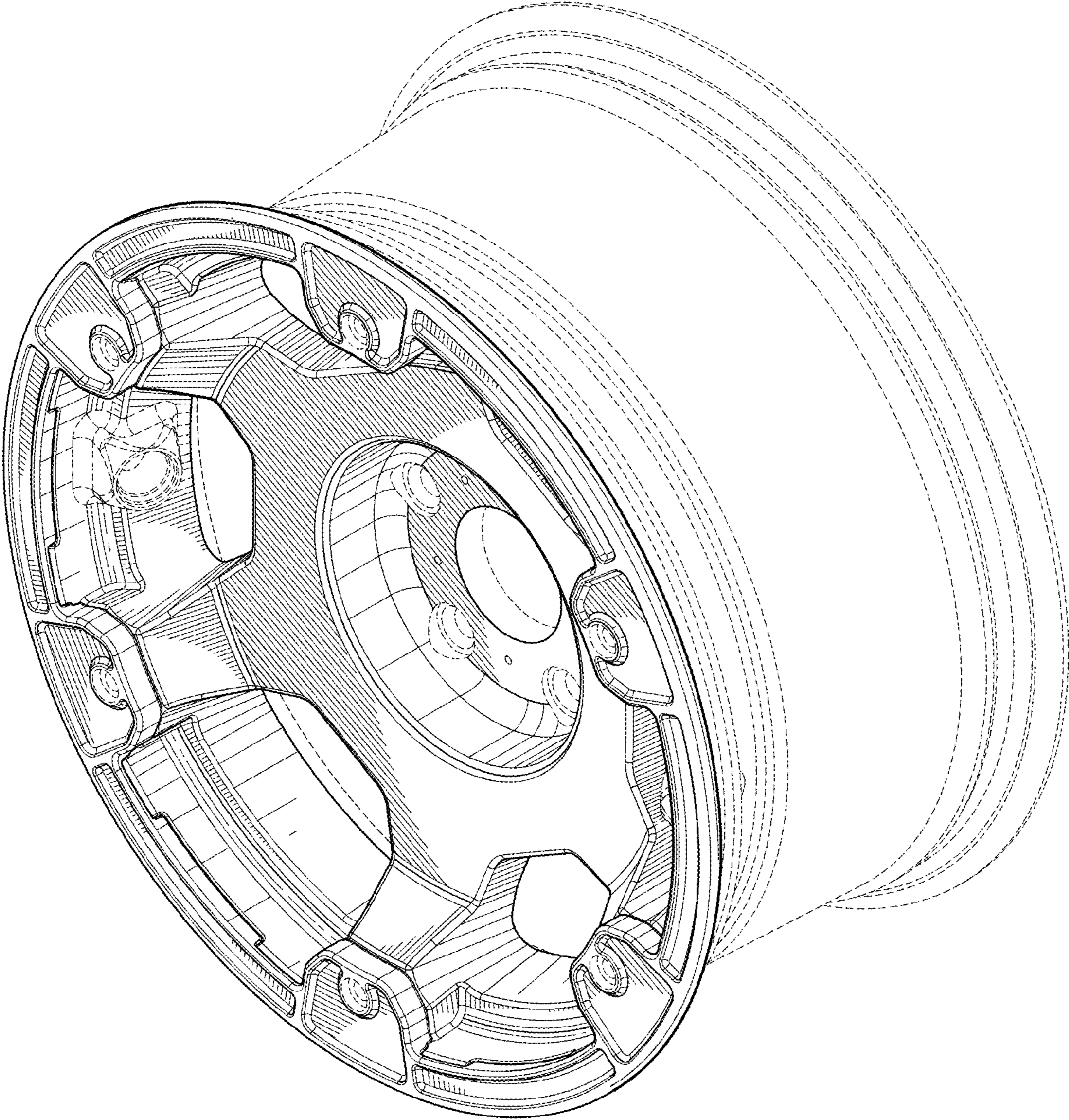

Fig. 4

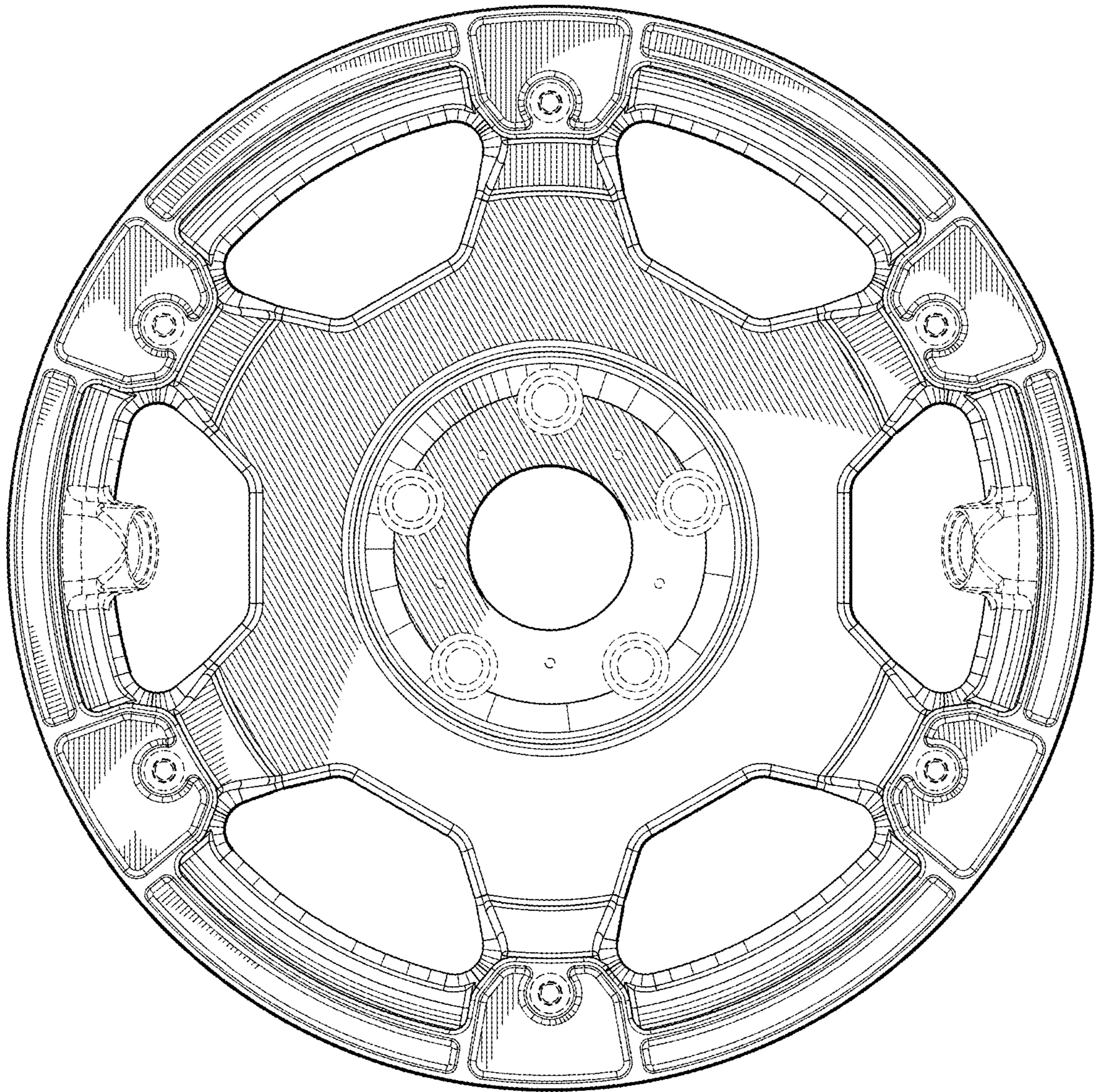

Fig. 5

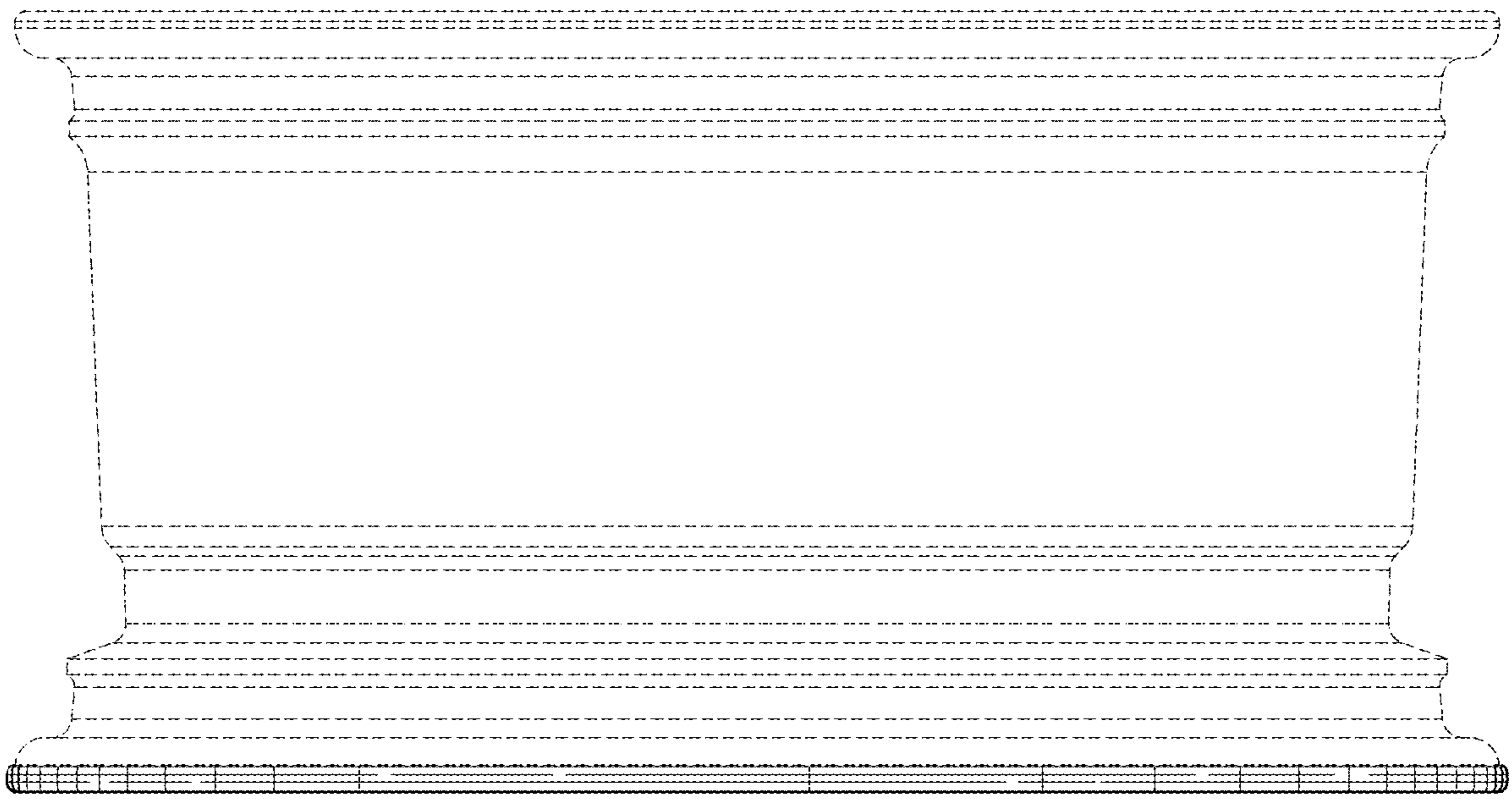

Fig. 6