



US00D891995S

(12) **United States Design Patent**  
**Campbell**

(10) **Patent No.:** **US D891,995 S**

(45) **Date of Patent:** **\*\* Aug. 4, 2020**

(54) **PERSONAL ELECTRIC VEHICLE**

7,182,356 B1 \* 2/2007 Haase ..... A61G 5/00  
280/250.1

(71) Applicant: **Centaur Robotics Limited**, London  
(GB)

D565,474 S \* 4/2008 Webster ..... D12/128

D565,475 S \* 4/2008 Webster ..... D12/128

D642,962 S \* 8/2011 Morris ..... D12/128

(72) Inventor: **Paul Campbell**, London (GB)

D648,093 S \* 11/2011 Woodhams ..... D34/35

D730,250 S \* 5/2015 Lodato ..... D12/128

(73) Assignee: **Centaur Robotics Limited**, London  
(GB)

\* cited by examiner

(\*\*) Term: **15 Years**

*Primary Examiner* — Charles D Hanson

(74) *Attorney, Agent, or Firm* — Ziegler IP Law Group  
LLC.

(21) Appl. No.: **29/646,923**

(22) Filed: **May 8, 2018**

(57) **CLAIM**

(30) **Foreign Application Priority Data**

The ornamental design for a personal electric vehicle, as  
shown and described.

May 8, 2018 (EM) ..... 005262417

(51) **LOC (12) Cl.** ..... **12-12**

(52) **U.S. Cl.**

USPC ..... **D12/131**

(58) **Field of Classification Search**

USPC ..... D12/128–133

CPC ..... A61G 5/00–14

See application file for complete search history.

**DESCRIPTION**

(56) **References Cited**

**U.S. PATENT DOCUMENTS**

D305,318 S \* 1/1990 Danecker ..... D12/131

7,156,208 B2 \* 1/2007 Rickaby ..... B66B 9/0838

104/288

FIG. 1 is a front perspective view of a personal electric  
vehicle showing the new design;  
FIG. 2 is a rear perspective view thereof;  
FIG. 3 is a front view thereof;  
FIG. 4 is a rear view thereof;  
FIG. 5 is a right side view thereof;  
FIG. 6 is a left side view thereof;  
FIG. 7 is a top view thereof; and,  
FIG. 8 is a bottom view thereof.

**1 Claim, 8 Drawing Sheets**

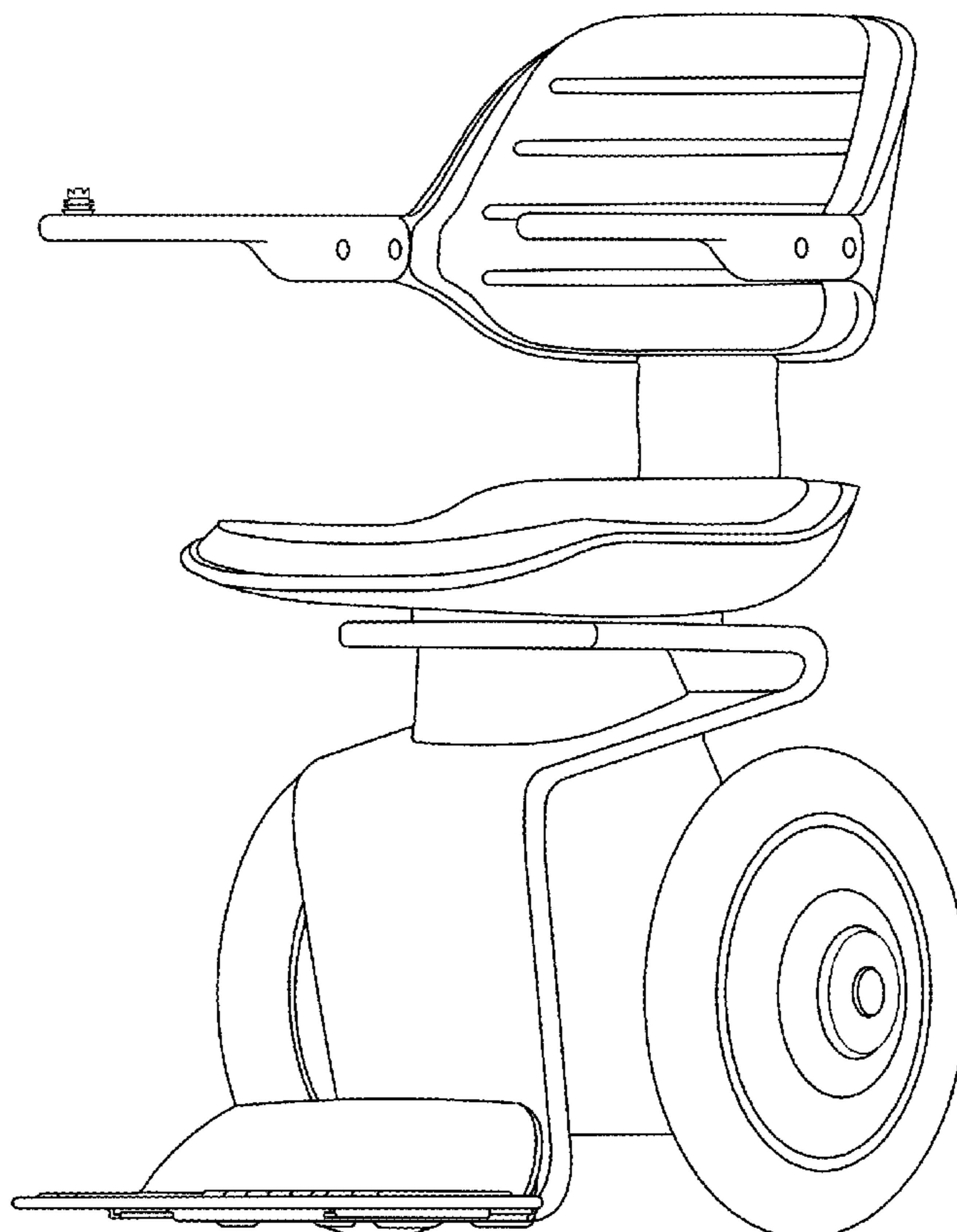

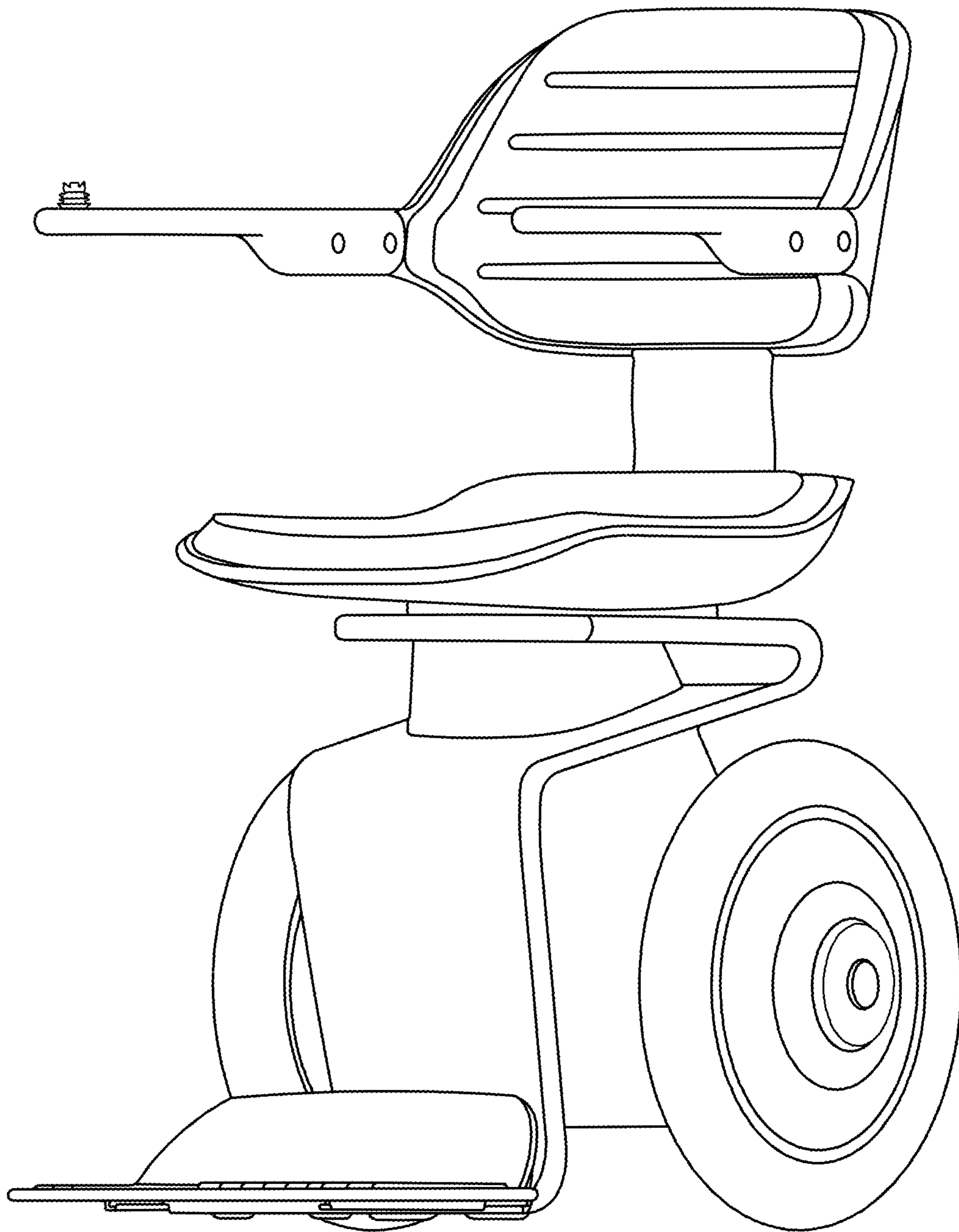

FIG. 1

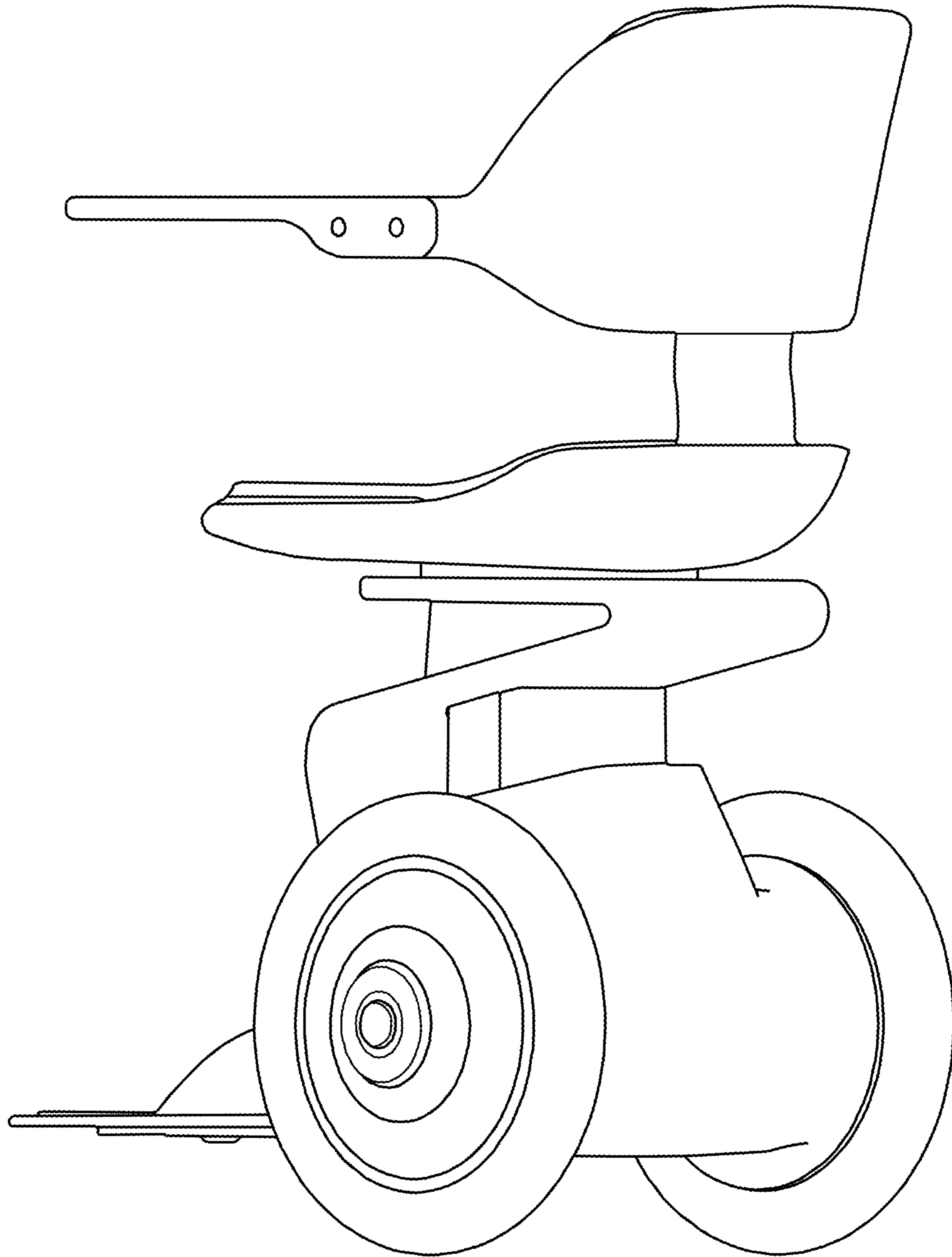

FIG. 2

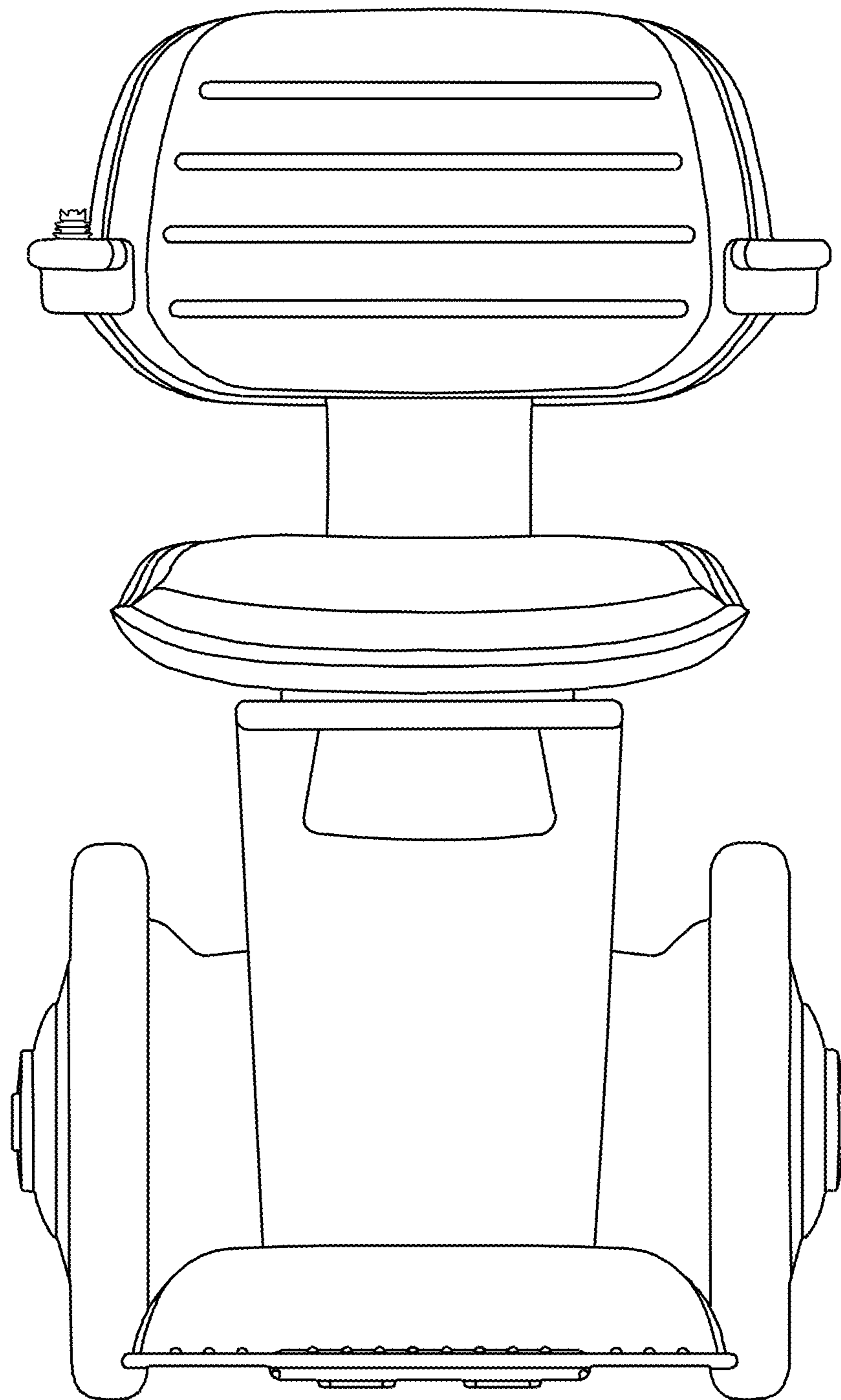

FIG. 3

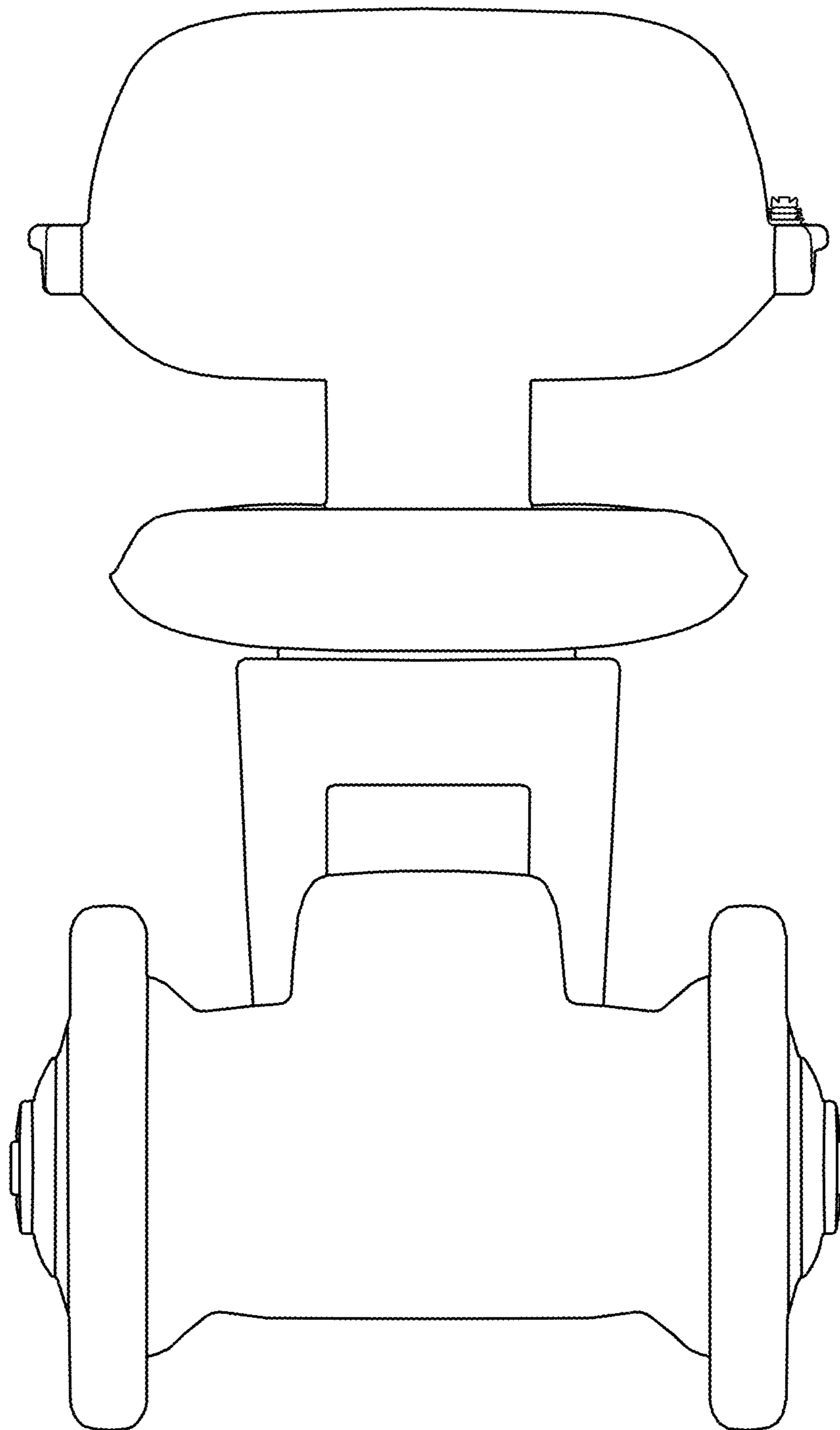

FIG. 4

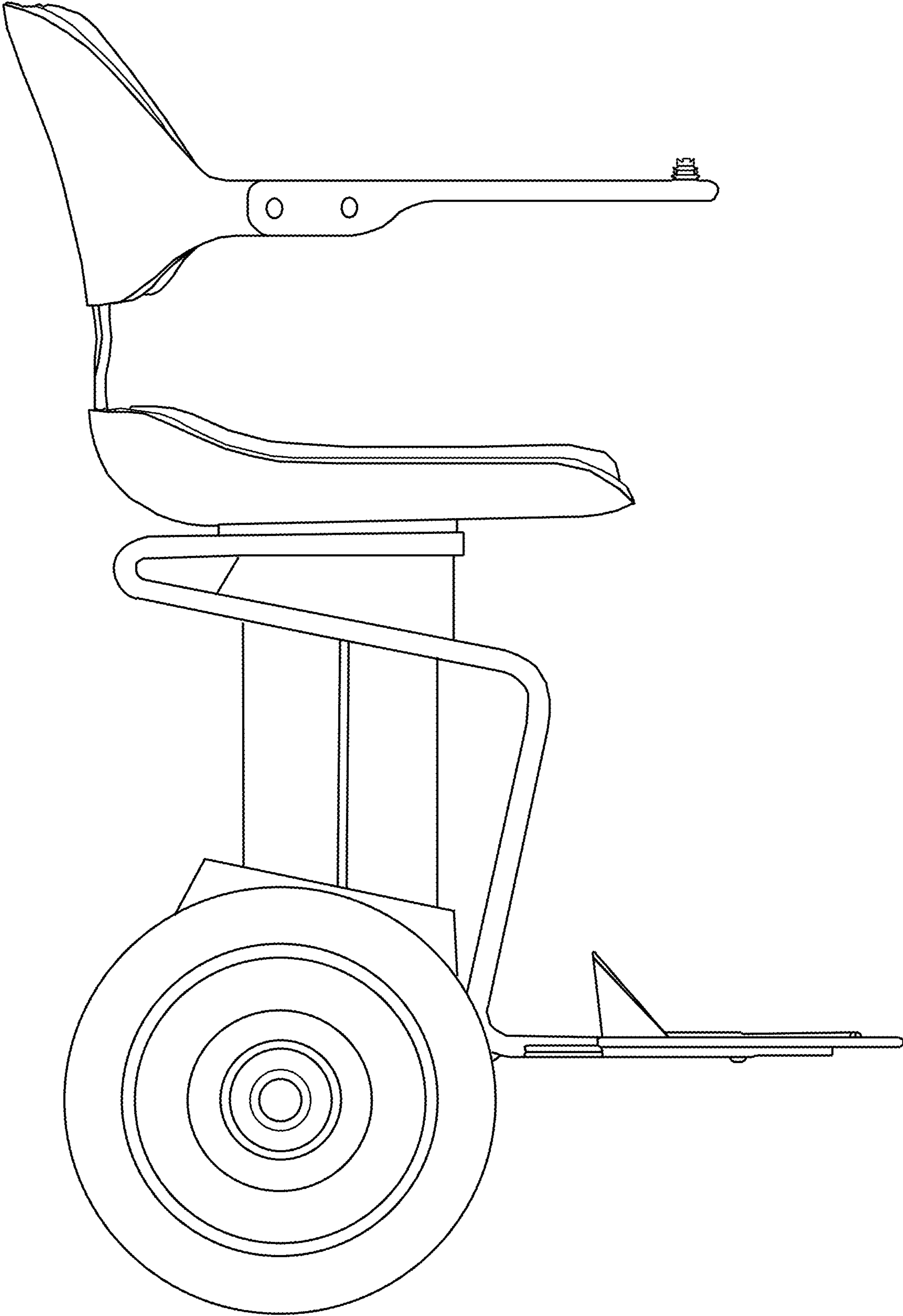

FIG. 5

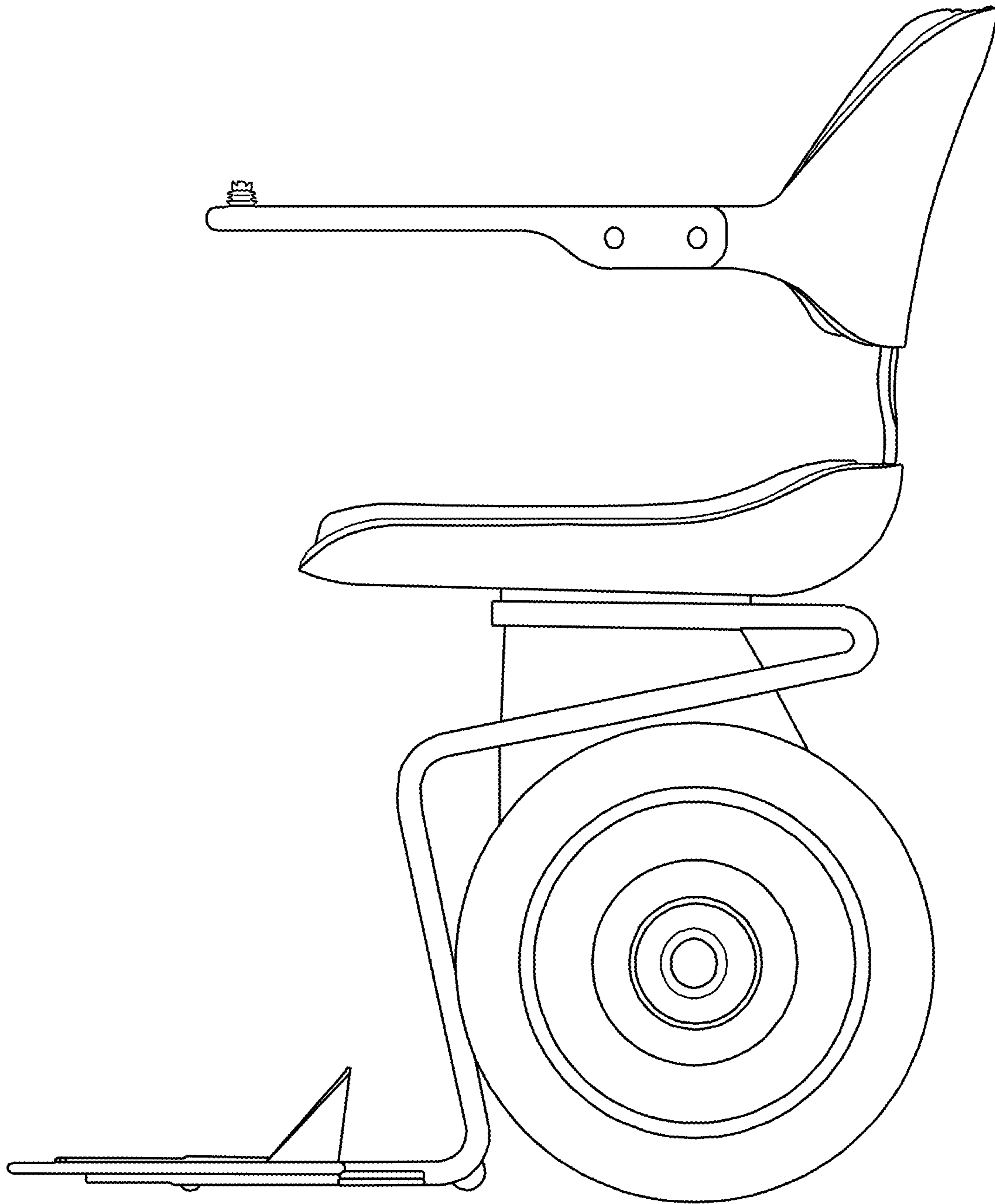

FIG. 6

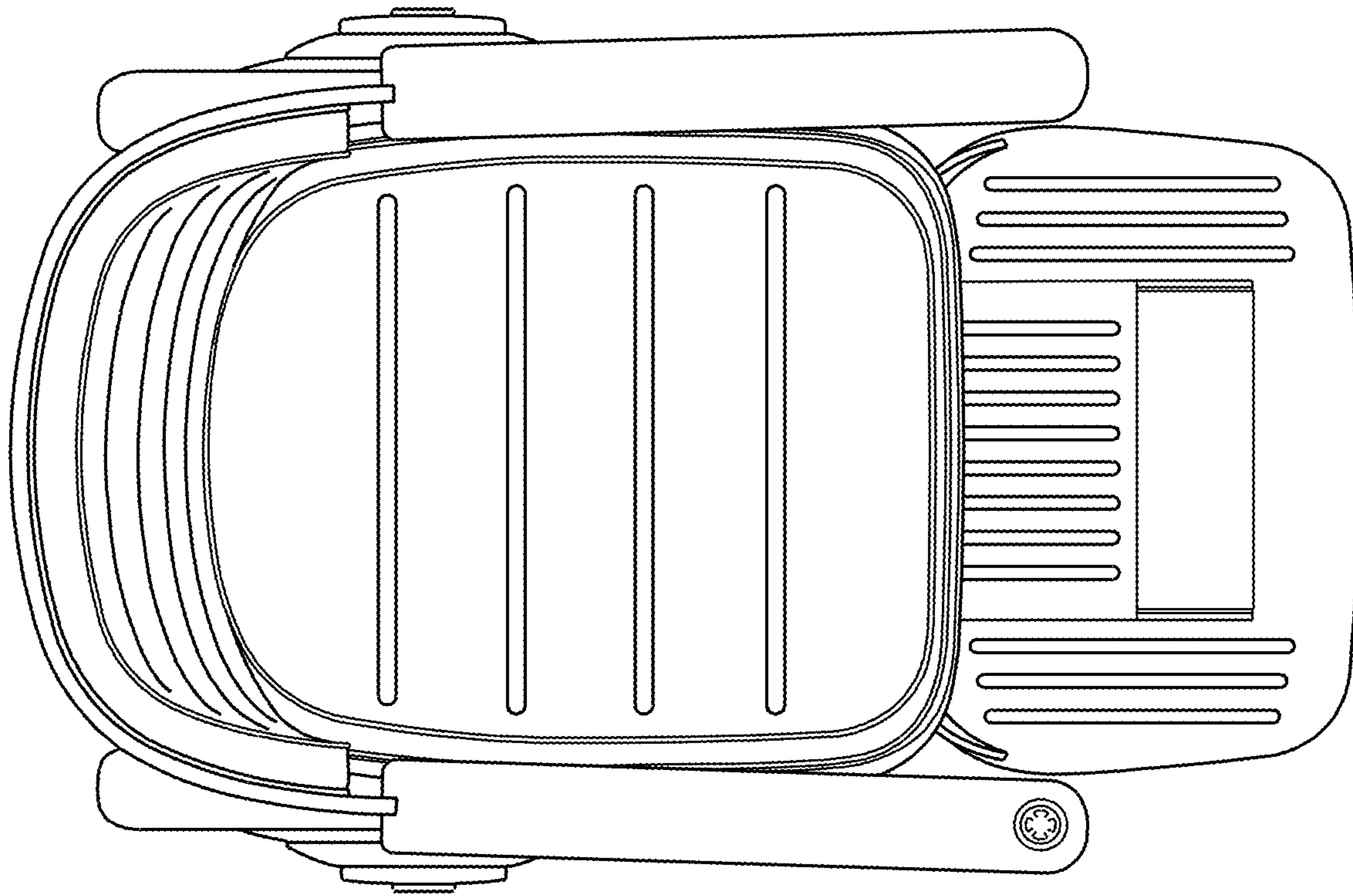

FIG. 7



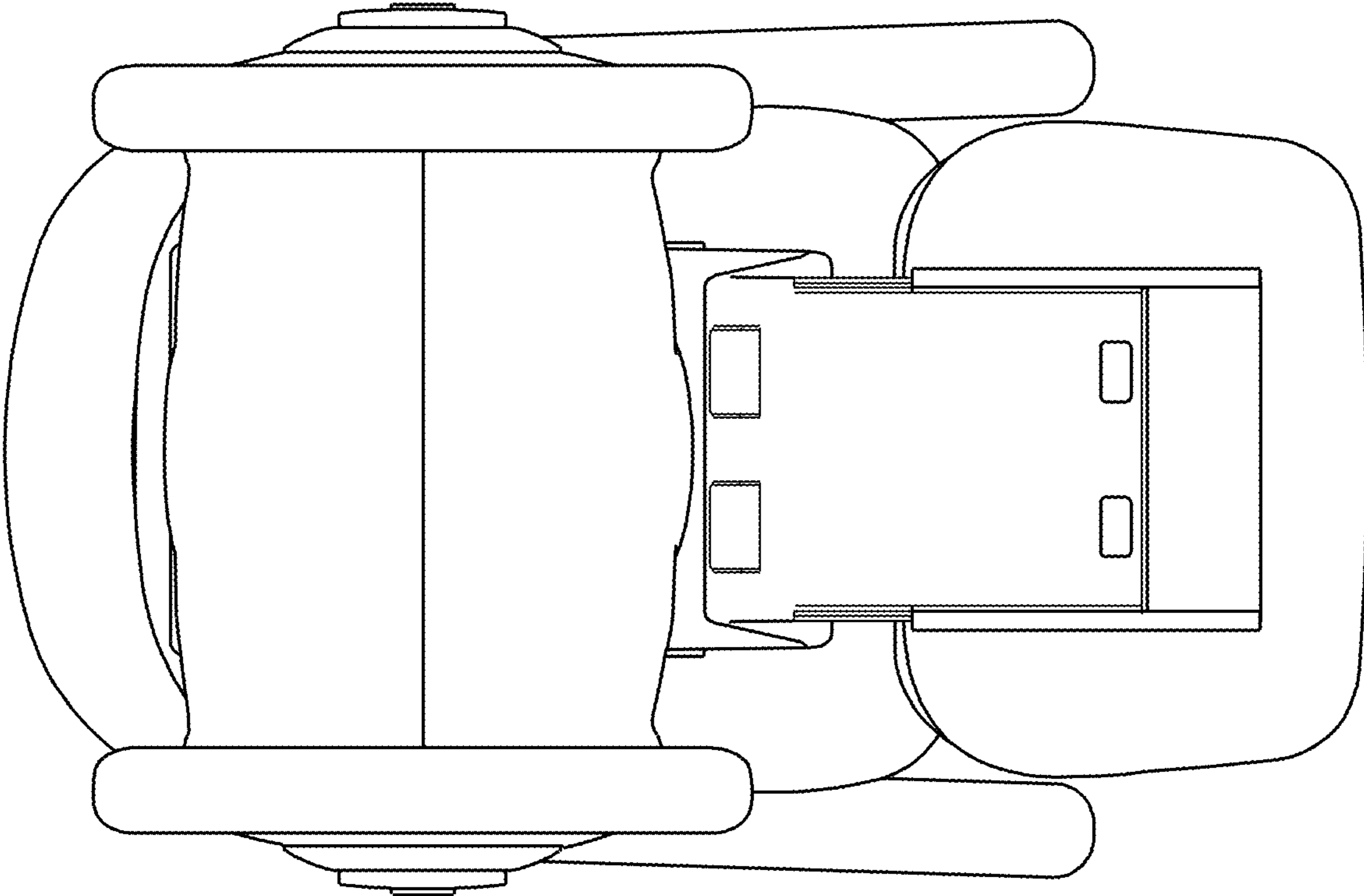

FIG. 8