



US00D891604S

(12) **United States Design Patent** (10) **Patent No.:** **US D891,604 S**
Daniels (45) **Date of Patent:** **** Jul. 28, 2020**

- (54) **ROOF VENT ASSEMBLY**
- (71) Applicant: **Gregory S. Daniels**, Santa Rosa, CA (US)
- (72) Inventor: **Gregory S. Daniels**, Santa Rosa, CA (US)
- (**) Term: **15 Years**
- (21) Appl. No.: **29/618,892**
- (22) Filed: **Sep. 25, 2017**

3,895,467 A	7/1975	Clement
3,951,336 A	4/1976	Miller et al.
4,040,867 A	8/1977	Forestieri et al.
4,051,999 A	10/1977	Granger et al.
D247,510 S	3/1978	Kujawa, Jr.
4,083,097 A	4/1978	Anagnostou et al.
4,097,308 A	6/1978	Klein et al.
D249,158 S	8/1978	Morrow
4,108,580 A	8/1978	Felter
4,189,881 A	2/1980	Hawley
D254,442 S	3/1980	Cervone
4,201,121 A	5/1980	Brandenburg, Jr.
4,224,081 A	9/1980	Kawanura et al.
4,228,729 A	10/1980	Messick
4,239,555 A	12/1980	Scharkack et al.
4,251,026 A	2/1981	Siegel et al.
D259,138 S	5/1981	Giles
D261,803 S	11/1981	Bohanon, Jr.
4,314,548 A	2/1982	Hanson
4,382,435 A	5/1983	Brill-Edwards
4,383,129 A	5/1983	Gupta et al.
4,404,958 A	9/1983	Boettcher
4,418,685 A	12/1983	Frazier
4,432,273 A	2/1984	Devitt
4,433,200 A	2/1984	Jester et al.
D276,261 S	11/1984	Shaftner
4,485,264 A	11/1984	Izu et al.
4,498,267 A	2/1985	Beck
4,501,194 A	2/1985	Brown
4,510,851 A	4/1985	Sarnosky et al.
4,574,160 A	3/1986	Cull et al.
4,594,940 A	6/1986	Wolbrink et al.
4,602,739 A	6/1986	Sutton, Jr.
D285,829 S	9/1986	Lock
4,625,469 A	12/1986	Gentry et al.
4,633,769 A	1/1987	Milks
4,651,805 A	3/1987	Bergeron, Jr.
4,677,903 A	7/1987	Mathews, III
4,692,557 A	9/1987	Samuelson et al.
4,759,272 A	7/1988	Zaniewski
4,803,816 A	2/1989	Klober
4,843,794 A	7/1989	Holtgreve
4,850,166 A	7/1989	Taylor
4,860,509 A	8/1989	Laaly et al.
4,965,971 A	10/1990	Jean-Jacques et al.
4,977,818 A	12/1990	Taylor et al.
4,986,469 A	1/1991	Sutton, Jr.
D318,109 S *	7/1991	Sullivan D23/354
5,048,255 A	9/1991	Gonzales
5,049,801 A	9/1991	Potter
5,060,444 A	10/1991	Paquette
5,070,771 A	12/1991	Mankowski
5,078,047 A	1/1992	Wimberly

Related U.S. Application Data

- (63) Continuation-in-part of application No. 29/546,178, filed on Nov. 19, 2015, now Pat. No. Des. 841,797.
- (51) **LOC (12) Cl.** **23-03**
- (52) **U.S. Cl.**
USPC **D23/393**
- (58) **Field of Classification Search**
USPC D23/387, 354, 419, 393
CPC F24F 7/00; F24F 7/02
See application file for complete search history.

References Cited

U.S. PATENT DOCUMENTS

D30,059 S	1/1899	Tracy
2,299,317 A	10/1942	Fink
D134,477 S	12/1942	Leslie
2,551,223 A	5/1951	Schneider
2,638,835 A	5/1953	Strawsine
2,692,548 A	10/1954	Knorr
2,733,649 A	2/1956	Le Barron
3,027,090 A	3/1962	Zerhan, Jr.
3,083,633 A	4/1963	Hochberg
D204,715 S	5/1966	Warner
3,376,164 A	4/1968	Bachwansky
3,459,597 A	8/1969	Baron
D215,940 S	11/1969	Kahn
D217,610 S	5/1970	Stoop
3,553,030 A	1/1971	Lebrun
3,658,596 A	4/1972	Osborne
3,769,091 A	10/1973	Leinkram et al.
3,888,697 A	6/1975	Bogus et al.

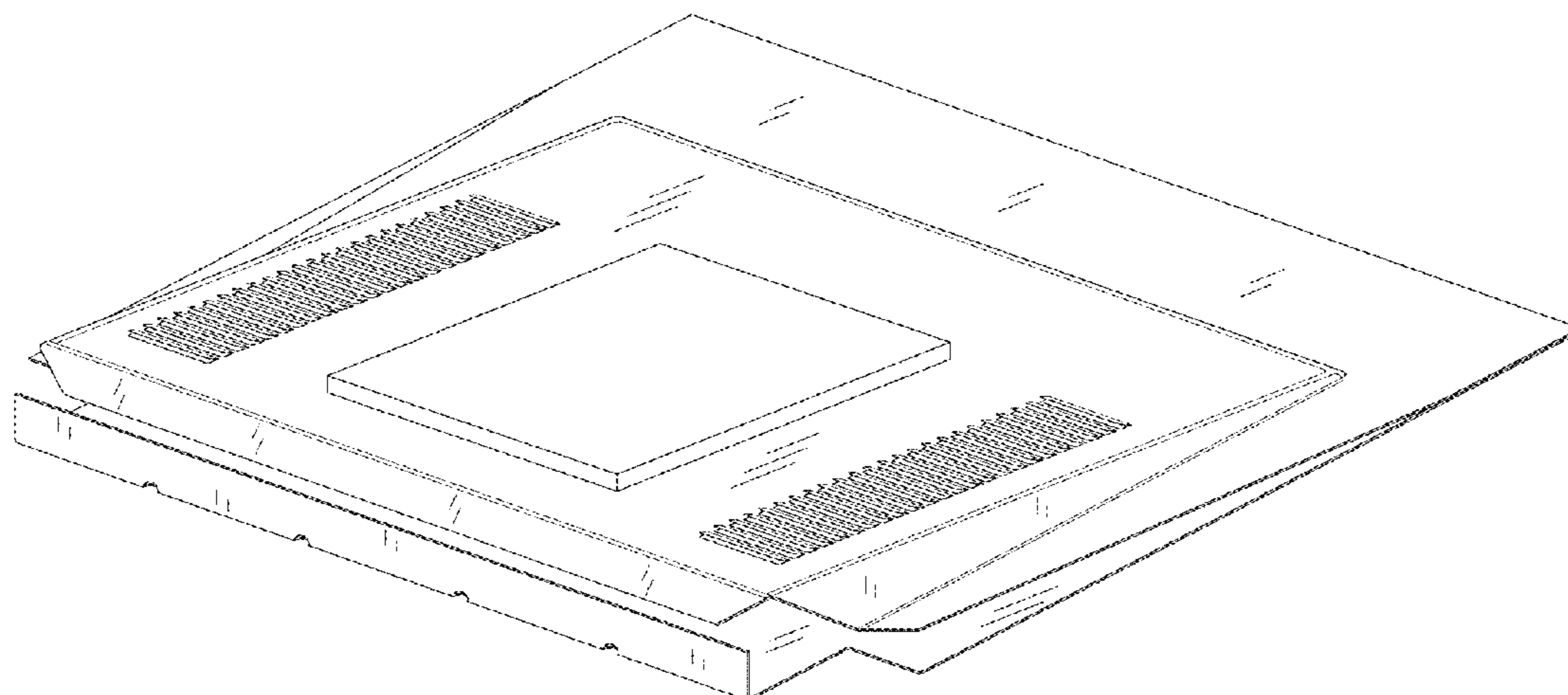

US D891,604 S

5,092,939 A	3/1992	Nath et al.	6,336,304 B1	1/2002	Mimura et al.
5,094,697 A	3/1992	Takabayashi et al.	6,340,403 B1	1/2002	Carey et al.
5,121,583 A	6/1992	Hirai et al.	6,365,824 B1	4/2002	Nakazima et al.
5,131,200 A	7/1992	McKinnon	6,380,477 B1	4/2002	Curtin
5,131,888 A	7/1992	Adkins, II	D457,234 S	5/2002	O'Hagin et al.
5,133,810 A	7/1992	Morizane et al.	D458,391 S	6/2002	O'Haqin et al.
D332,139 S	12/1992	Courchesne	D458,392 S	6/2002	O'Haqin et al.
5,176,758 A	1/1993	Nath et al.	6,415,559 B1	7/2002	Reeves et al.
5,228,925 A	7/1993	Nath et al.	6,418,678 B2	7/2002	Rotter
5,232,518 A	8/1993	Nath et al.	6,439,466 B2	8/2002	Fikes
5,238,519 A	8/1993	Nath et al.	6,447,390 B1	9/2002	O'Hagin
D342,129 S *	12/1993	Goetz, Jr. D23/387	6,453,629 B1	9/2002	Nakazima et al.
5,273,608 A	12/1993	Nath	6,459,032 B1	10/2002	Luch
5,296,043 A	3/1994	Kawakami et al.	6,491,579 B1	12/2002	O'Hagin
5,316,592 A	5/1994	Dinwoodie	6,501,013 B1	12/2002	Dinwoodie
5,326,318 A	7/1994	Rotter	6,541,693 B2	4/2003	Takada et al.
5,333,783 A	8/1994	Catan	6,553,729 B1	4/2003	Nath et al.
5,364,026 A	11/1994	Kundert	6,606,830 B2	8/2003	Nagao et al.
5,385,848 A	1/1995	Grimmer	D479,885 S	9/2003	O'Hagin et al.
5,391,235 A	2/1995	Inoue	6,695,692 B1	2/2004	York
5,409,549 A	4/1995	Mori	D489,834 S	5/2004	Weston
5,419,781 A	5/1995	Hamakawa et al.	6,729,081 B2	5/2004	Nath et al.
5,437,735 A	8/1995	Younan et al.	6,730,841 B2	5/2004	Heckerroth
5,480,494 A	1/1996	Inoue	6,767,762 B2	7/2004	Guha
5,486,238 A	1/1996	Nakagawa et al.	6,799,742 B2	10/2004	Nakamura et al.
5,505,788 A	4/1996	Dinwoodie	D503,156 S	3/2005	Provenzano
5,528,229 A	6/1996	Mehta	6,870,087 B1	3/2005	Gallagher
5,549,513 A	8/1996	Thomas et al.	D503,790 S	4/2005	Dodge et al.
D374,927 S *	10/1996	Chabot D23/386	D504,172 S	4/2005	O'Hagin
5,575,861 A	11/1996	Younan et al.	6,875,914 B2	4/2005	Guha et al.
5,591,080 A	1/1997	Ward	D505,195 S	5/2005	Snyder
5,602,457 A	2/1997	Anderson et al.	6,928,775 B2	8/2005	Banister
5,620,368 A	4/1997	Bates et al.	6,941,706 B2	9/2005	Austin et al.
5,636,481 A	6/1997	De Zen	D512,774 S	12/2005	O'Hagin et al.
D380,823 S	7/1997	LaZar	D518,158 S	3/2006	Cho et al.
5,651,226 A	7/1997	Archibald	D519,219 S	4/2006	Dodge et al.
5,672,101 A	9/1997	Thomas	D520,149 S	5/2006	Dodge et al.
5,697,192 A	12/1997	Inoue	7,044,852 B2	5/2006	Horton
5,697,842 A	12/1997	Donnelly	7,053,294 B2	5/2006	Tuttle et al.
5,706,617 A	1/1998	Hirai et al.	7,097,557 B2	8/2006	Kutschman
5,722,887 A	3/1998	Wolfson et al.	D527,813 S	9/2006	Dodge et al.
5,738,581 A	4/1998	Rickert et al.	D527,836 S	9/2006	O'Hagin
5,740,636 A	4/1998	Archard	7,101,279 B2	9/2006	O'Hagin et al.
5,746,653 A	5/1998	Palmer et al.	D536,778 S	2/2007	O'Hagin
5,746,839 A	5/1998	Dinwoodie	D537,519 S	2/2007	Sigillo
5,766,071 A	6/1998	Kirkwood	7,176,543 B2	2/2007	Beernink
D397,431 S	8/1998	Meyer	7,178,295 B2	2/2007	Dinwoodie
5,800,631 A	9/1998	Yamada et al.	D538,422 S *	3/2007	Hooijmaaijers D23/387
5,816,909 A	10/1998	Wunder	7,250,000 B2	7/2007	Daniels, II
D403,755 S	1/1999	Liang	D549,316 S	8/2007	O'Hagin et al.
5,879,232 A	3/1999	Luter, II et al.	D555,237 S	11/2007	O'Hagin
D408,514 S	4/1999	Hornig	7,320,774 B2	1/2008	Simmons et al.
5,890,322 A	4/1999	Fears	D562,440 S *	2/2008	Negrao D23/354
D409,741 S	5/1999	Yuen-Ming	D562,993 S	2/2008	Shepherd et al.
5,968,287 A	10/1999	Nath	7,365,266 B2	4/2008	Heckerroth
5,990,414 A	11/1999	Posnansky	D578,633 S	10/2008	Schluter et al.
6,005,236 A	12/1999	Phelan et al.	D579,096 S	10/2008	Guzorek
6,008,450 A	12/1999	Ohtsuka et al.	D580,542 S	11/2008	Miyake
6,036,102 A	3/2000	Pearson	D582,905 S	12/2008	Takisawa et al.
6,050,039 A	4/2000	O'Hagin	7,469,508 B2	12/2008	Ceria
6,051,774 A	4/2000	Yoshida et al.	7,470,179 B1	12/2008	Ritter et al.
D424,186 S	5/2000	Dodson	D588,255 S	3/2009	Daniels
D424,672 S *	5/2000	Nanjo D23/353	D588,256 S	3/2009	Daniels
6,061,977 A	5/2000	Toyama et al.	D589,134 S	3/2009	O'Hagin et al.
6,061,978 A	5/2000	Dinwoodie et al.	7,497,774 B2	3/2009	Stevenson et al.
6,077,159 A	6/2000	Clayton	7,506,477 B2	3/2009	Flaherty et al.
6,105,317 A	8/2000	Tomiuchi et al.	7,507,151 B1	3/2009	Parker et al.
6,129,628 A	10/2000	O'Hagin et al.	7,509,775 B2	3/2009	Flaherty et al.
6,155,006 A	12/2000	Mimura et al.	7,517,465 B2	4/2009	Guha et al.
6,220,956 B1	4/2001	Kilian et al.	7,531,740 B2	4/2009	Flaherty et al.
D442,273 S	5/2001	Pestell	D593,193 S	5/2009	Jackson
6,241,602 B1	6/2001	Allen	D595,402 S	6/2009	Miyake
6,242,685 B1	6/2001	Mizukami et al.	7,578,102 B2	8/2009	Banister
6,243,995 B1	6/2001	Reeves et al.	D601,237 S *	9/2009	Nishio D23/354
D444,869 S	7/2001	Yip	7,587,864 B2	9/2009	McCaskill et al.
6,294,724 B1	9/2001	Sasaoka et al.	7,618,310 B2	11/2009	Daniels
6,306,030 B1	10/2001	Wilson	7,642,449 B2	1/2010	Korman et al.
D450,378 S	11/2001	Minakuchi	D610,245 S	2/2010	Daniels
6,311,436 B1	11/2001	Mimura et al.	D612,040 S	3/2010	Daniels

7,678,990 B2 3/2010 McCaskill et al.
D618,780 S 6/2010 Williams, Sr.
7,736,940 B2 6/2010 Basol
7,757,440 B2 7/2010 Austin et al.
D625,800 S 10/2010 Daniels
7,901,278 B2 3/2011 O'Hagin
8,079,898 B1 12/2011 Stevenson
D654,161 S 2/2012 Holland et al.
8,167,216 B2 5/2012 Schultz et al.
8,292,707 B2 10/2012 Grisham et al.
8,316,592 B2 11/2012 Lanza
D685,112 S 6/2013 Henriquez
D685,113 S 6/2013 Henriquez
8,479,458 B2 7/2013 Morita et al.
8,535,128 B2 9/2013 Chwala
D696,392 S 12/2013 Funnell, II
8,607,510 B2 12/2013 Daniels
8,608,533 B2 12/2013 Daniels
D702,827 S 4/2014 Mase et al.
D703,305 S 4/2014 Stollenwerk O'Hagin
8,701,360 B2 4/2014 Ressler
8,740,678 B2 6/2014 Railkar et al.
8,776,455 B2 7/2014 Azoulay
8,782,967 B2 7/2014 Daniels
8,793,943 B2 8/2014 Daniels
D713,953 S 9/2014 Jepson
D719,253 S 12/2014 Francescon
9,011,221 B2 4/2015 Daniels
D748,239 S 1/2016 Daniels
D755,944 S 5/2016 Daniels
D766,413 S * 9/2016 Zhou D23/354
D768,276 S * 10/2016 Kim D23/354
D779,650 S 2/2017 Poehlman et al.
D788,281 S 5/2017 Daniels
D788,902 S 6/2017 Daniels
D796,661 S 9/2017 Oswald
D810,257 S * 2/2018 Lai D23/354
D812,211 S * 3/2018 Daniels D23/371
D841,797 S * 2/2019 Daniels D23/393
2001/0027804 A1 10/2001 Inoue et al.
2001/0040201 A1 11/2001 Paxton
2002/0036010 A1 3/2002 Yamawaki et al.
2002/0104562 A1 8/2002 Emoto et al.
2003/0000158 A1 1/2003 Borges
2003/0159802 A1 8/2003 Steneby et al.
2004/0031219 A1 2/2004 Banister
2004/0098932 A1 5/2004 Broatch
2005/0074915 A1 4/2005 Tuttle et al.
2005/0127379 A1 6/2005 Nakata
2005/0130581 A1 6/2005 Dodge
2005/0144963 A1 7/2005 Peterson et al.
2005/0176270 A1 8/2005 Luch
2005/0178429 A1 8/2005 McCaskill et al.
2005/0191957 A1 9/2005 Demetry et al.
2005/0233691 A1 10/2005 Horton
2005/0239393 A1 10/2005 Reese
2005/0239394 A1 10/2005 O'Hagin et al.
2005/0263178 A1 12/2005 Montello et al.
2005/0263179 A1 12/2005 Gaudiana et al.
2005/0263180 A1 12/2005 Montello et al.
2005/0274408 A1 12/2005 Li et al.
2006/0017154 A1 1/2006 Eguchi et al.
2006/0032527 A1 2/2006 Stevens et al.
2006/0052047 A1 3/2006 Daniels, II
2006/0052051 A1 3/2006 Daniels
2006/0086384 A1 4/2006 Nakata
2006/0124827 A1 6/2006 Janus et al.
2006/0199527 A1 9/2006 Peters
2006/0223437 A1 10/2006 O'Hagin
2007/0049190 A1 3/2007 Singh
2007/0066216 A1 3/2007 McIntire
2007/0067063 A1 3/2007 Ahmed
2007/0072541 A1 3/2007 Daniels et al.
2007/0084501 A1 4/2007 Kalberlah et al.
2007/0094953 A1 5/2007 Galeazzo et al.
2007/0173191 A1 7/2007 Daniels, II
2007/0178827 A1 8/2007 Erni
2007/0184775 A1 8/2007 Perkins
2007/0207725 A1 9/2007 O'Hagin

2007/0243820 A1 10/2007 O'Hagin
2007/0246095 A1 10/2007 Schaefer
2008/0040990 A1 2/2008 Vendig et al.
2008/0098672 A1 5/2008 O'Hagin et al.
2008/0163576 A1 7/2008 Oaten
2008/0220714 A1 9/2008 Caruso et al.
2008/0287053 A1 11/2008 Carlson et al.
2008/0287054 A1 11/2008 Carlson et al.
2008/0299892 A1 12/2008 Robinson
2009/0203308 A1 8/2009 O'Hagin
2009/0253368 A1 10/2009 Rotter
2009/0286463 A1 11/2009 Daniels
2009/0311959 A1 12/2009 Shepherd
2010/0064605 A1 3/2010 Corvaglia et al.
2010/0068985 A1 3/2010 Park
2010/0229940 A1 9/2010 Basol
2010/0287852 A1 11/2010 Bortoletto
2010/0300128 A1 12/2010 Chen
2010/0330898 A1 12/2010 Daniels
2011/0294412 A1 12/2011 Vagedes
2012/0110924 A1 5/2012 Makin
2012/0151856 A1 6/2012 Azoulay
2012/0178357 A1 7/2012 Rheume
2012/0190288 A1 7/2012 Willen
2012/0252348 A1 10/2012 Rheume
2012/0322359 A1 12/2012 Chen et al.
2013/0019548 A1 1/2013 Daniels
2013/0040553 A1 2/2013 Potter
2013/0078903 A1 3/2013 Mantyla et al.
2013/0247480 A1 9/2013 Ridgway
2014/0065944 A1 3/2014 Chamness
2014/0099878 A1 4/2014 Daniels
2014/0248834 A1 9/2014 Kolt et al.
2015/0143760 A1 5/2015 Daniels
2015/0253021 A1 9/2015 Daniels

FOREIGN PATENT DOCUMENTS

DE	28 04 301	2/1979
DE	198 23 356	11/1999
GB	2183819	6/1987
GB	2279453	1/1995
GB	2345536	7/2000
JP	59-060138	4/1984
JP	H06 13304 U	2/1994
JP	06-241517	8/1994
JP	06-272920	9/1994
JP	09-158428	6/1997
JP	10-061133	3/1998
JP	11-044035	2/1999
JP	11-229576	8/1999
JP	2000-274032	10/2000
JP	2002/357344	12/2002
JP	2004-092298	3/2004
JP	2007-534924	11/2007
WO	WO 05/108708	11/2005
WO	WO 2013/106882	7/2013

OTHER PUBLICATIONS

International Search Report for PCT/US2014/060964 dated Jan. 29, 2015.
Flat-Type Vent. Formfomts.com[online] 1 page. Designed/built 2008 [retrieved on Feb. 12, 2015]. <https://www.formfonts.com/3D-Model/11_030/1_/b3020-roof-openings/b3020-roof-openings/b3020-roof-openings/b3020-roof-openings/b3020-roof-openings/ohagins-concrete-tile-vent-type-flat/>.
Roof Vents. (1/8-Designs-© Questel). orbit.com [online PDF] 27 pages. Uploaded 2014 [retrieved on Feb. 12, 2015]. Retrieved from Internet: <<http://sobjprd.questel.fr/exportIQPTUJ214/pdf2/5f7850eaf617-4548-bc47-08c3edb41caO-222833.pdf>>.
S-Type Vent. Formfomts.com[online] 1 page. Designed/built 2008 [retrieved on Feb. 12, 2015]. <http://www.formfonts.com/3D-Model/11_032/shell/b30-roofing/b3010-roof-coverings/b3020-roof-openings/ohagins-concrete-tile-vent-type/>.
M-Type Vent. Formfomts.com[online] 1 page. Designed/built 2008 [retrieved on Feb. 12, 2015]. <<https://www.formfonts.com/3D->

Model/1 /11031/1 /shell/b30-roofing/b301 0-roof-coverings/b3020-roof-openings/ohagins-concrete-tile-vent-type-config/.

* cited by examiner

Primary Examiner — Charles D Hanson
(74) *Attorney, Agent, or Firm* — Knobbe Martens Olson & Bear LLP

(57) **CLAIM**

The ornamental design for a roof vent assembly, as shown and described.

DESCRIPTION

FIG. 1 is a top perspective view of a roof vent assembly;
FIG. 2 is a top view of the roof vent assembly of FIG. 1;
FIG. 3 is a bottom view of the roof vent assembly of FIG. 1;
FIG. 4 is a bottom view of an embodiment of the roof vent assembly of FIG. 1 without a lower screen;
FIG. 5 is a front view of the roof vent assembly of FIG. 1;
FIG. 6 is a rear view of the roof vent assembly of FIG. 1;
FIG. 7 is a right side view of the roof vent assembly of FIG. 1, with the left side view being a mirror image of FIG. 7;
FIG. 8 is a top perspective view of an embodiment of the roof vent assembly of FIG. 1, the only difference being the configuration of the bottom flange;
FIG. 9 is a top view of the roof vent assembly of FIG. 8;
FIG. 10 is a bottom view of the roof vent assembly of FIG. 8;

FIG. 11 is a bottom view of an embodiment of the roof vent assembly of FIG. 8 without a lower screen;
FIG. 12 is a front view of the roof vent assembly of FIG. 8;
FIG. 13 is a rear view of the roof vent assembly of FIG. 8;
FIG. 14 is a right side view of the roof vent assembly of FIG. 8, with the left side view being a mirror image of FIG. 14;
FIG. 15 is a top perspective view of another embodiment of the roof vent assembly of FIG. 1, without a solar panel;
FIG. 16 is a top view of the roof vent assembly of FIG. 15;
FIG. 17 is a bottom view of the roof vent assembly of FIG. 15;
FIG. 18 is a bottom view of an embodiment of the roof vent assembly of FIG. 15 without a lower screen;
FIG. 19 is a front view of the roof vent assembly of FIG. 15;
FIG. 20 is a rear view of the roof vent assembly of FIG. 15;
FIG. 21 is a right side view of the roof vent assembly of FIG. 15, with the left side view being a mirror image of FIG. 21;
FIG. 22 is a top perspective view of a second embodiment of the roof vent assembly of FIG. 15, the only difference being the configuration of the bottom flange;
FIG. 23 is a top view of the roof vent assembly of FIG. 22;
FIG. 24 is a bottom view of the roof vent assembly of FIG. 22;
FIG. 25 is a bottom view of an embodiment of the roof vent assembly of FIG. 22 without a lower screen;
FIG. 26 is a front view of the roof vent assembly of FIG. 22;
FIG. 27 is a rear view of the roof vent assembly of FIG. 22;
and,
FIG. 28 is a right side view of the roof vent assembly of FIG. 22, with the left side view being a mirror image of FIG. 28;

1 Claim, 24 Drawing Sheets

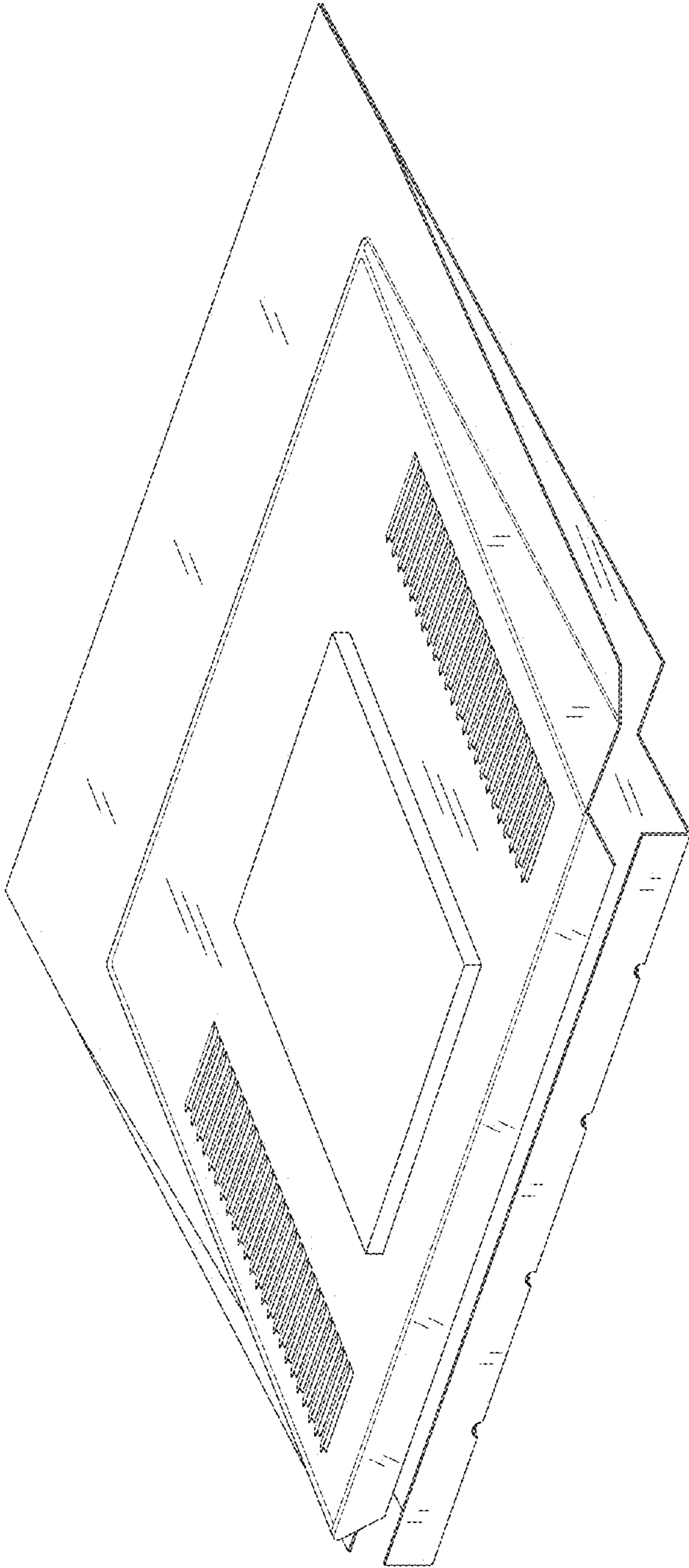

FIG. 1

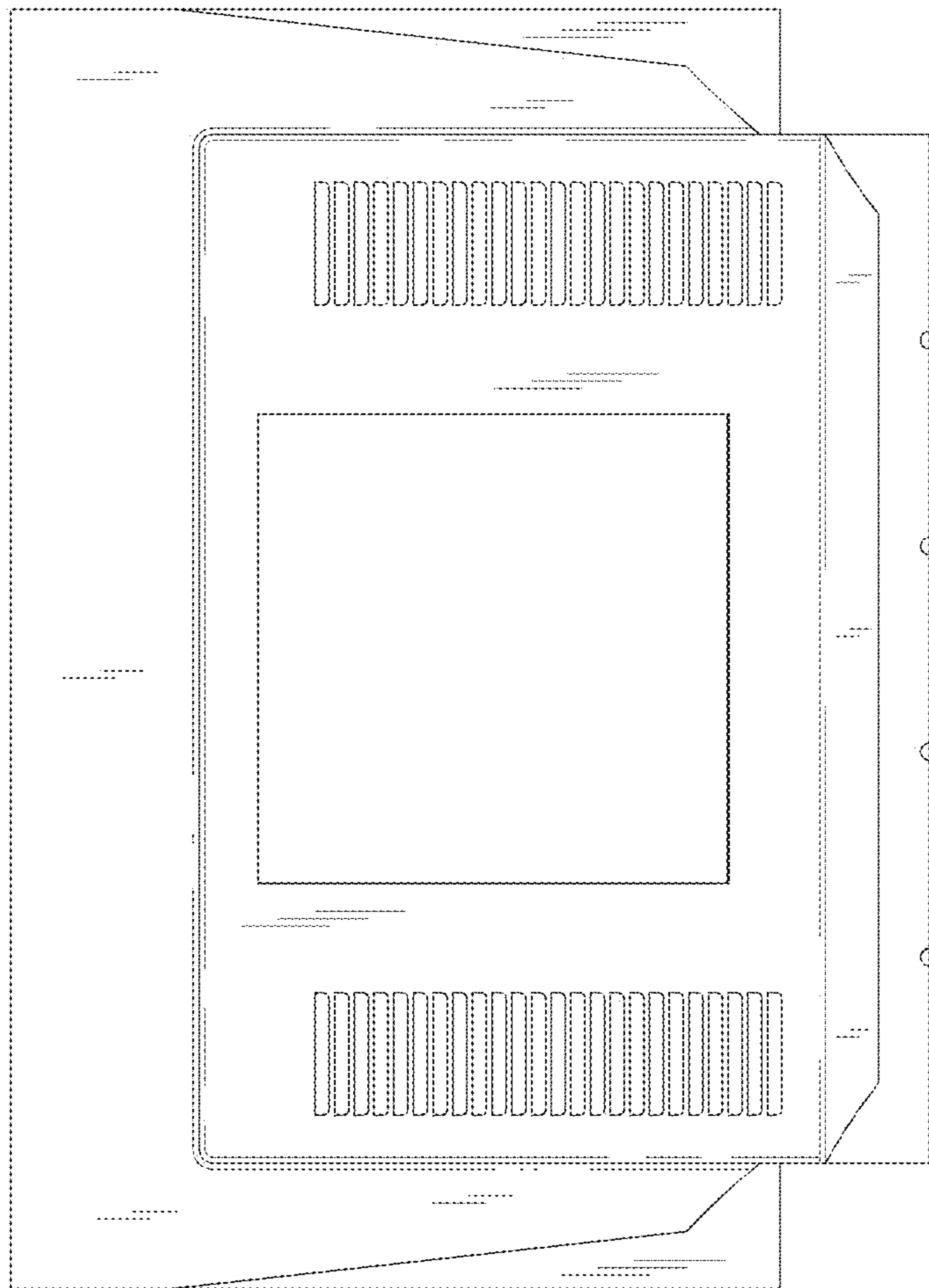

FIG. 2

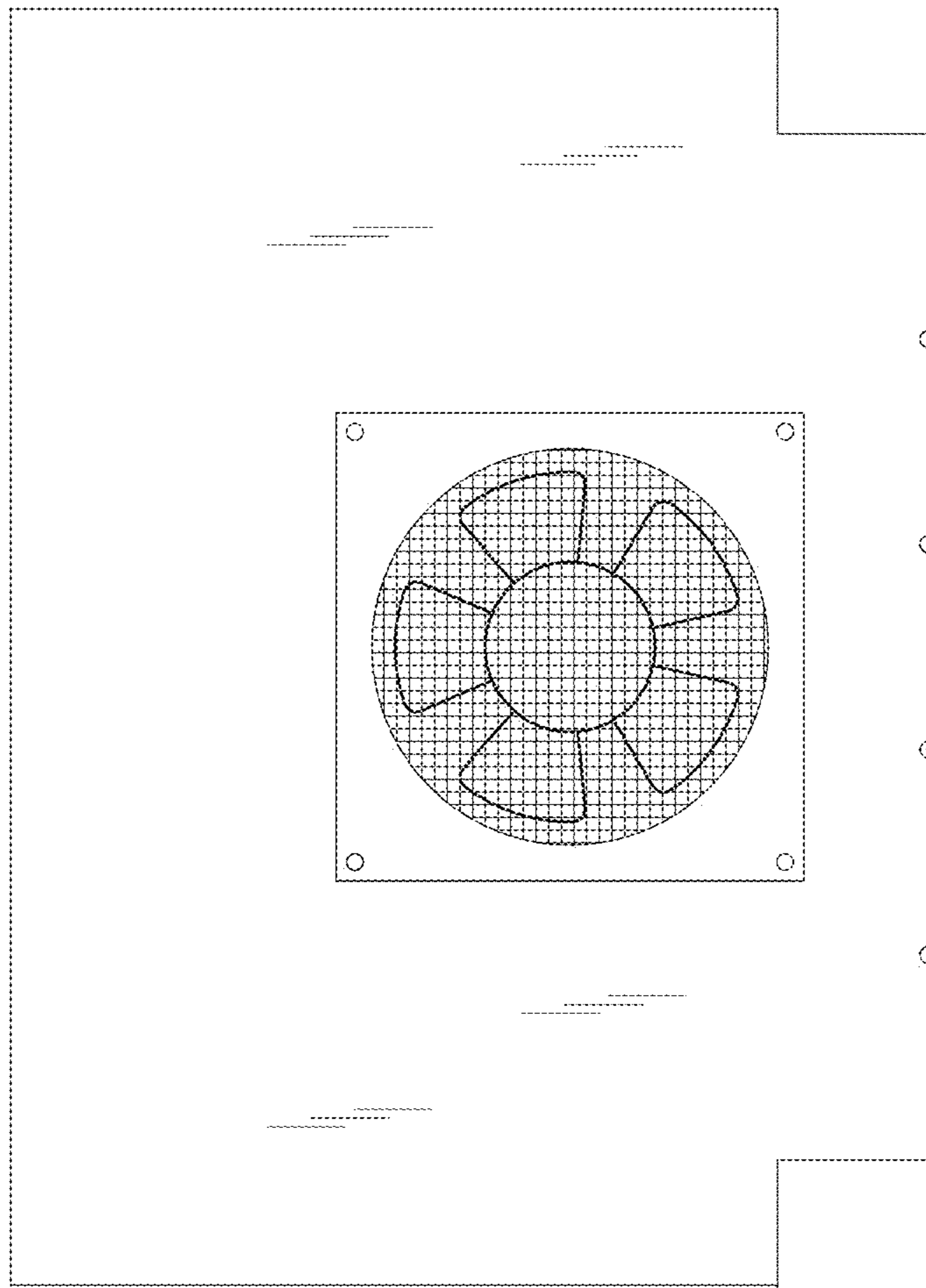

FIG. 3

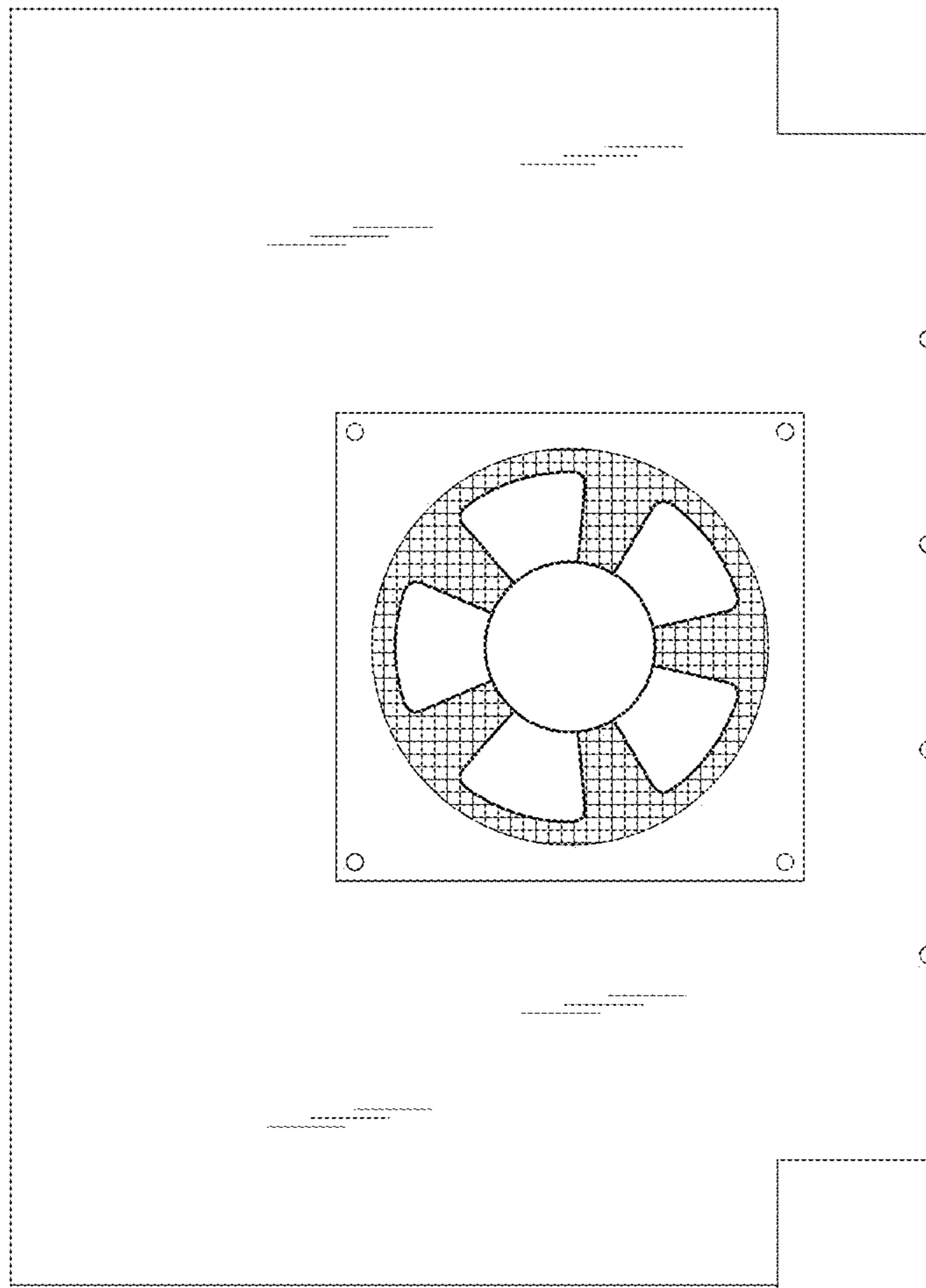

FIG. 4

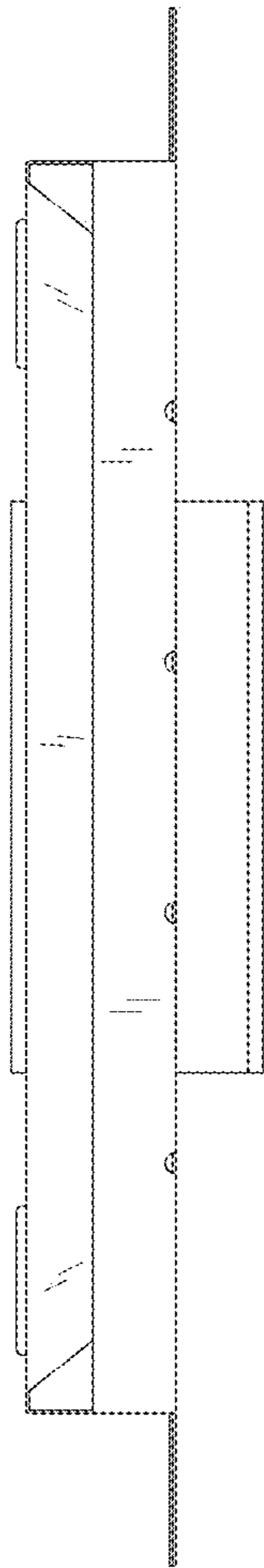

FIG. 5

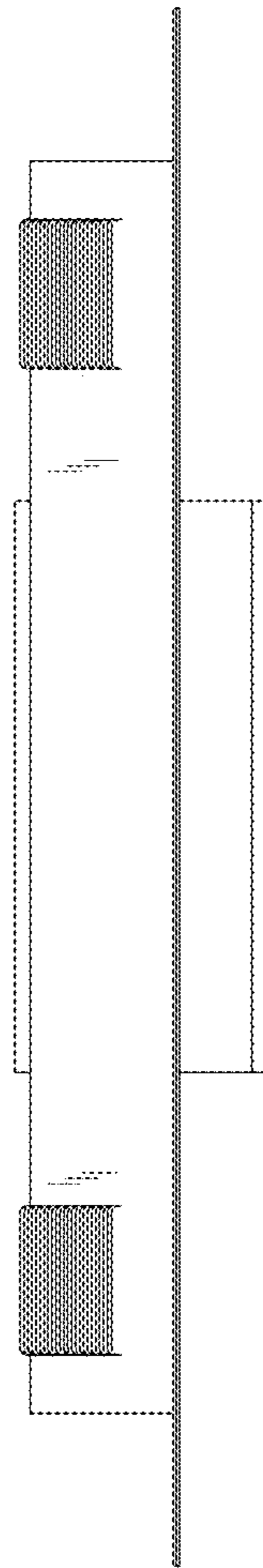

FIG. 6

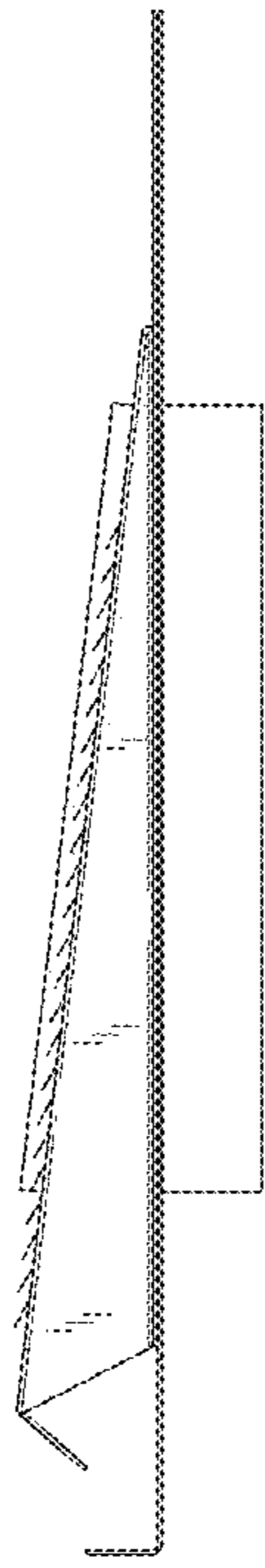

FIG. 7

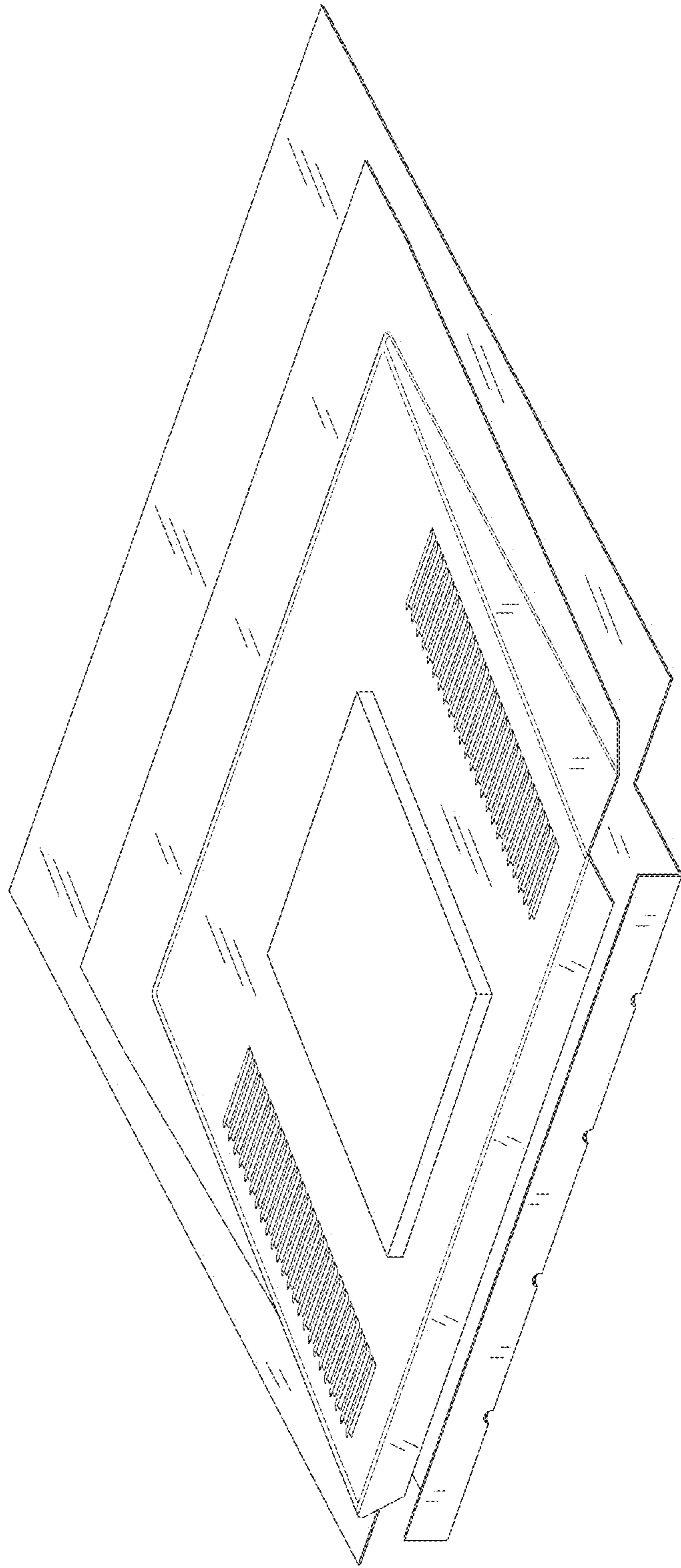

FIG. 8

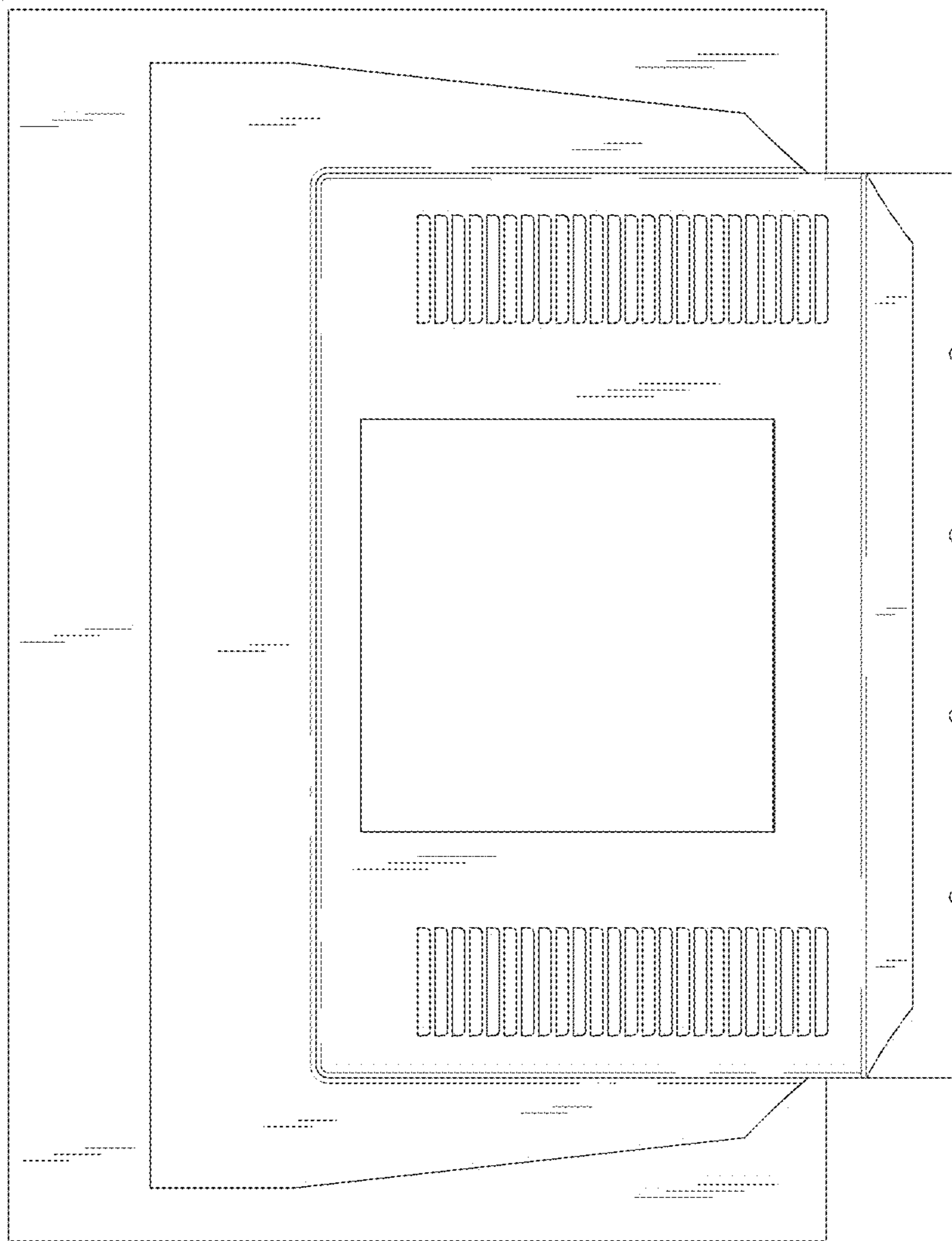

FIG. 9

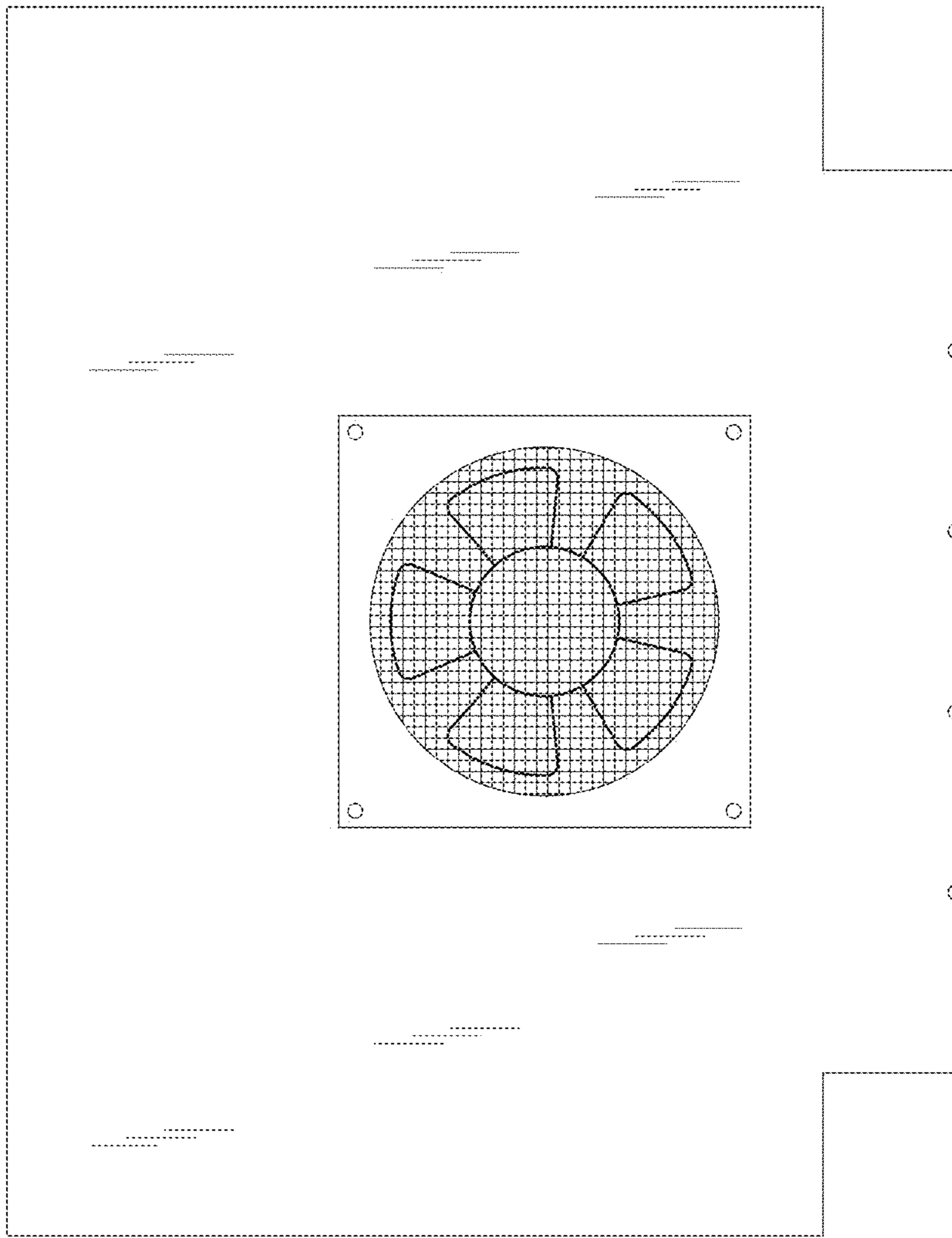

FIG. 10

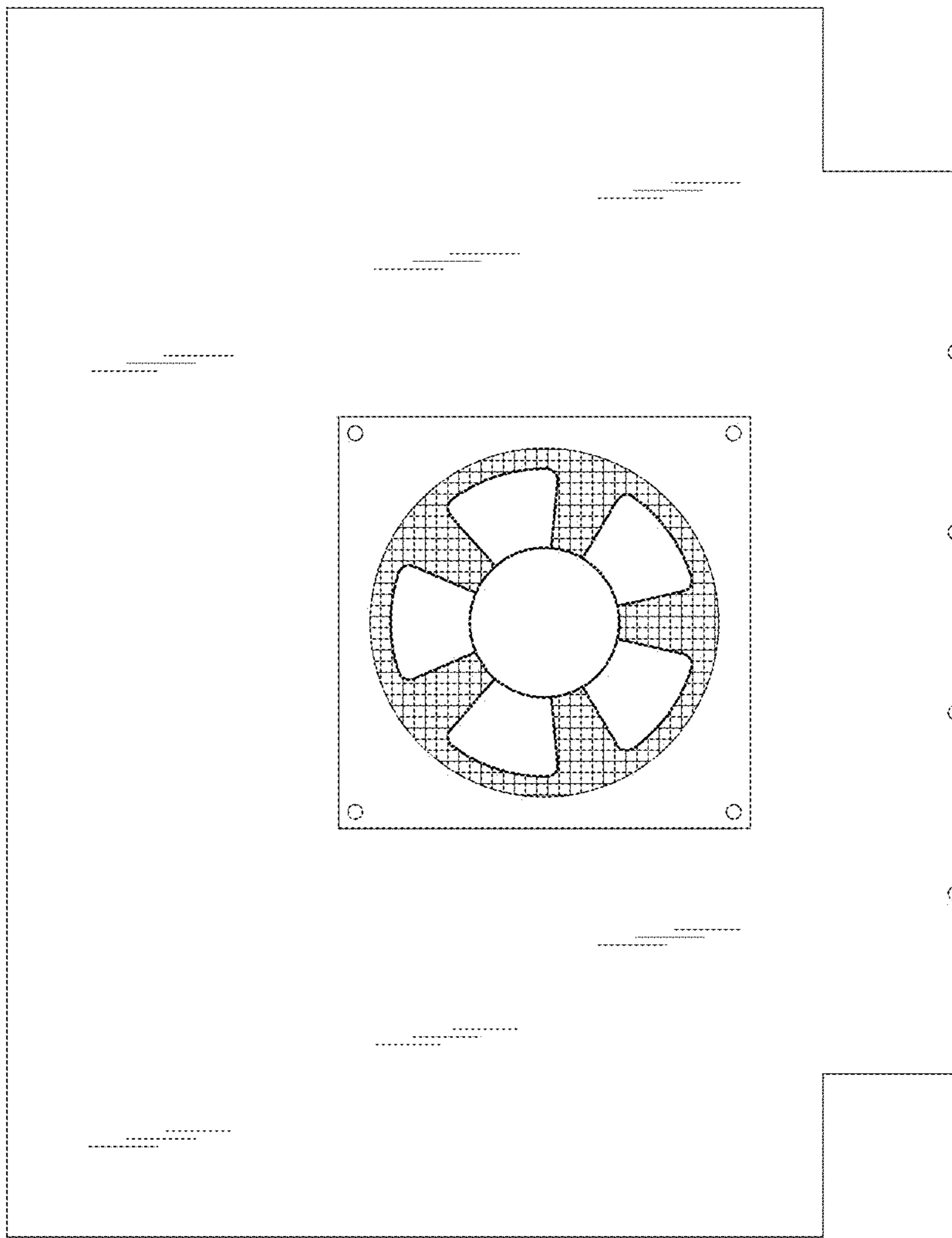

FIG. 11

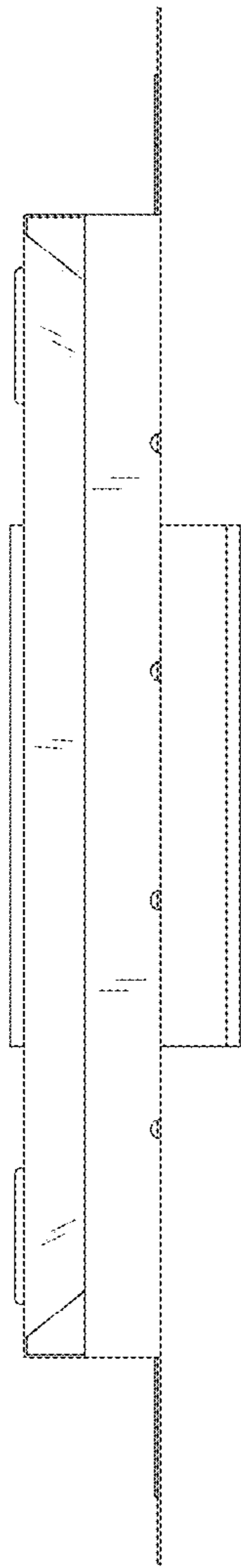

FIG. 12

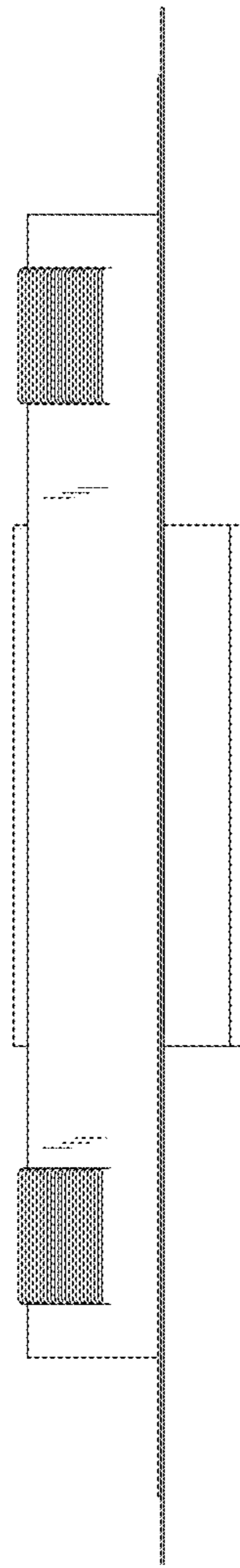

FIG. 13

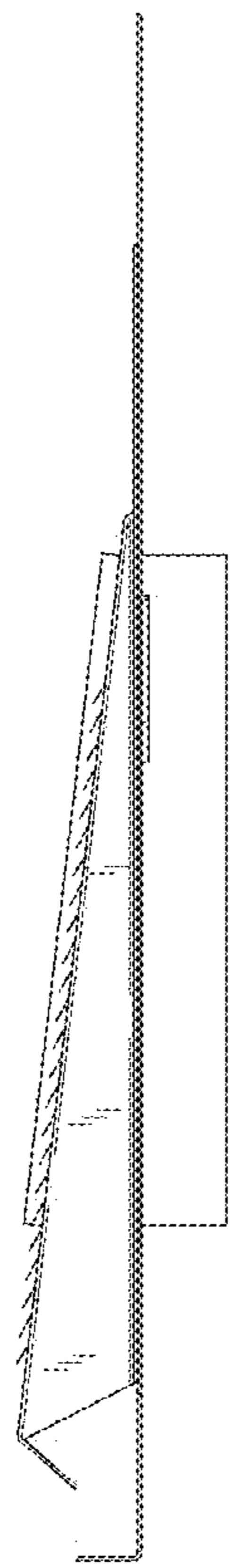

FIG. 14

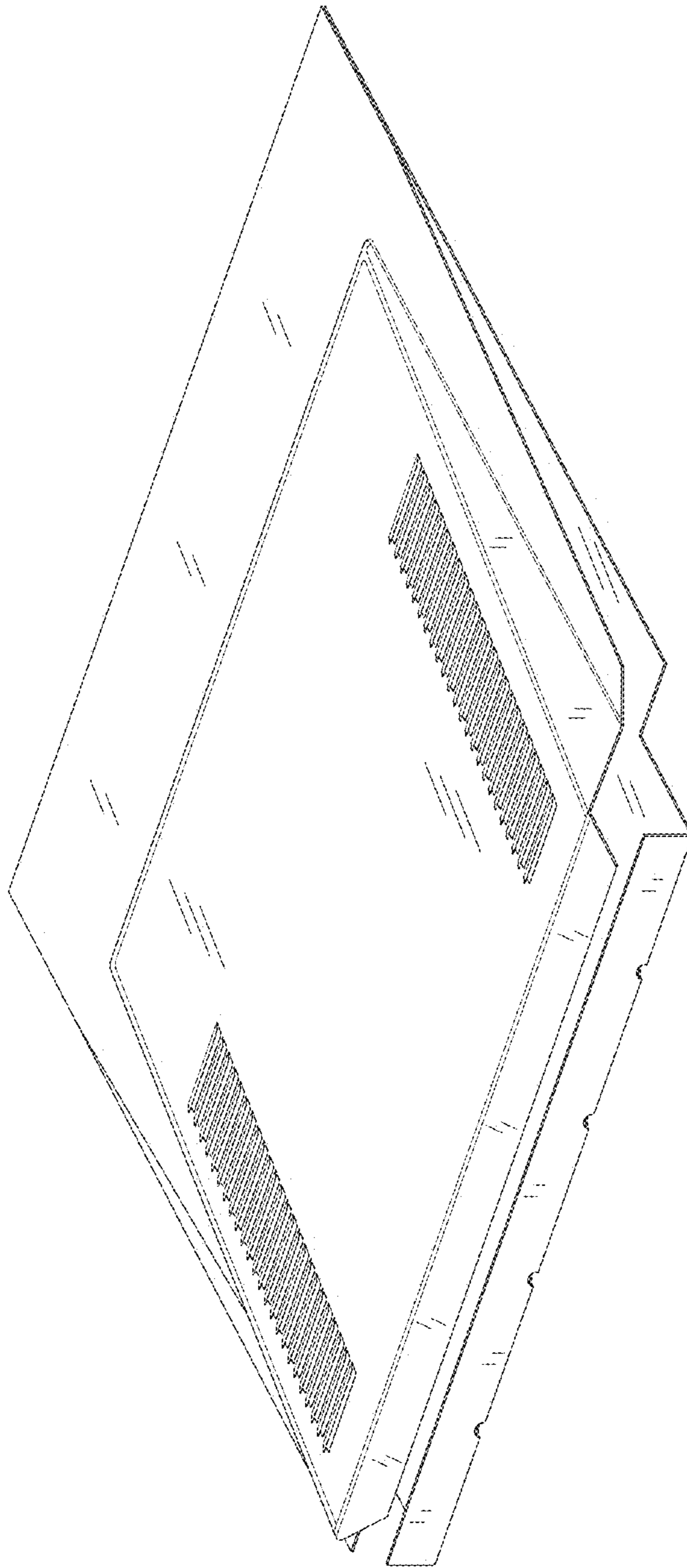

FIG. 15

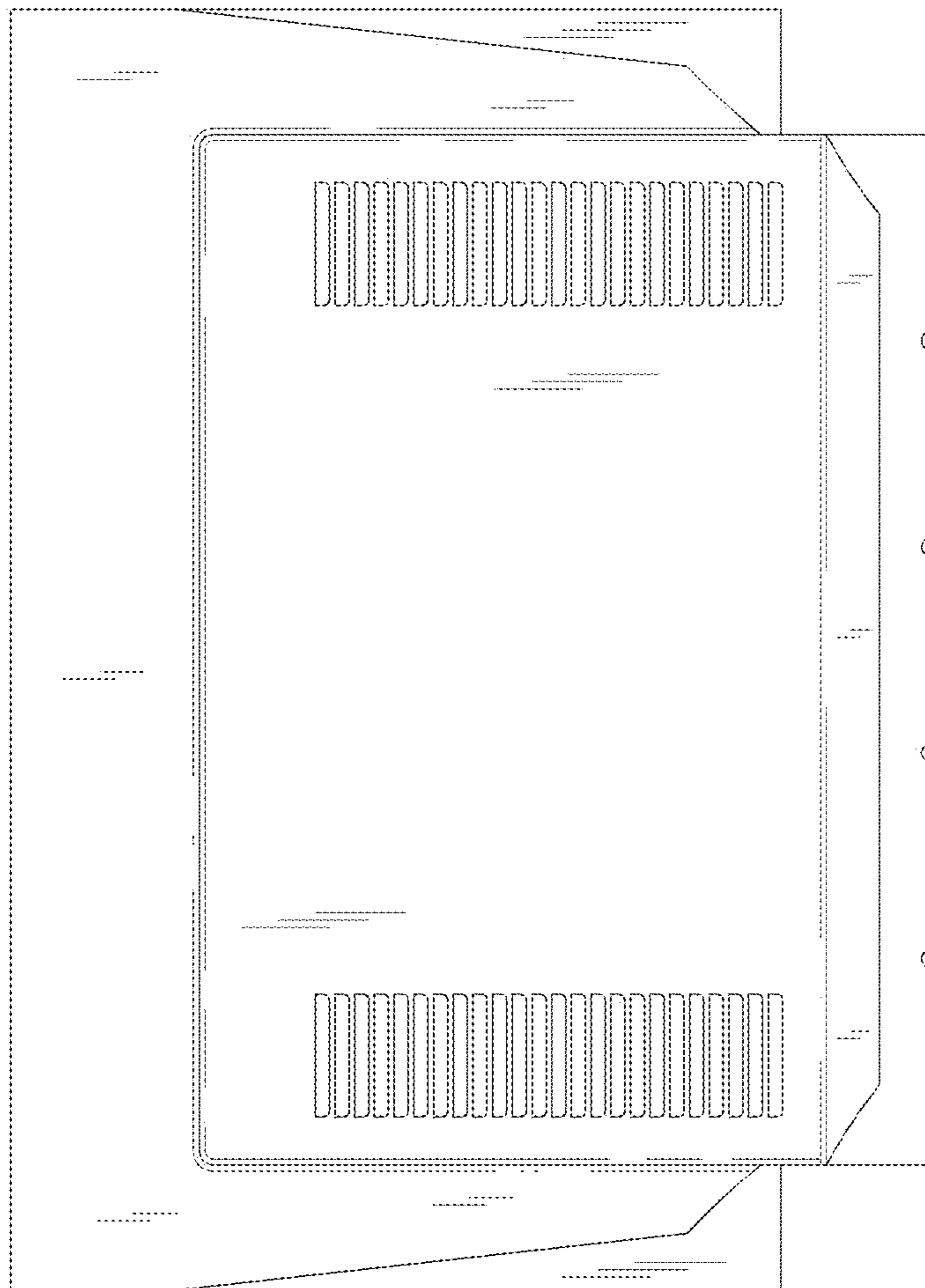

FIG. 16

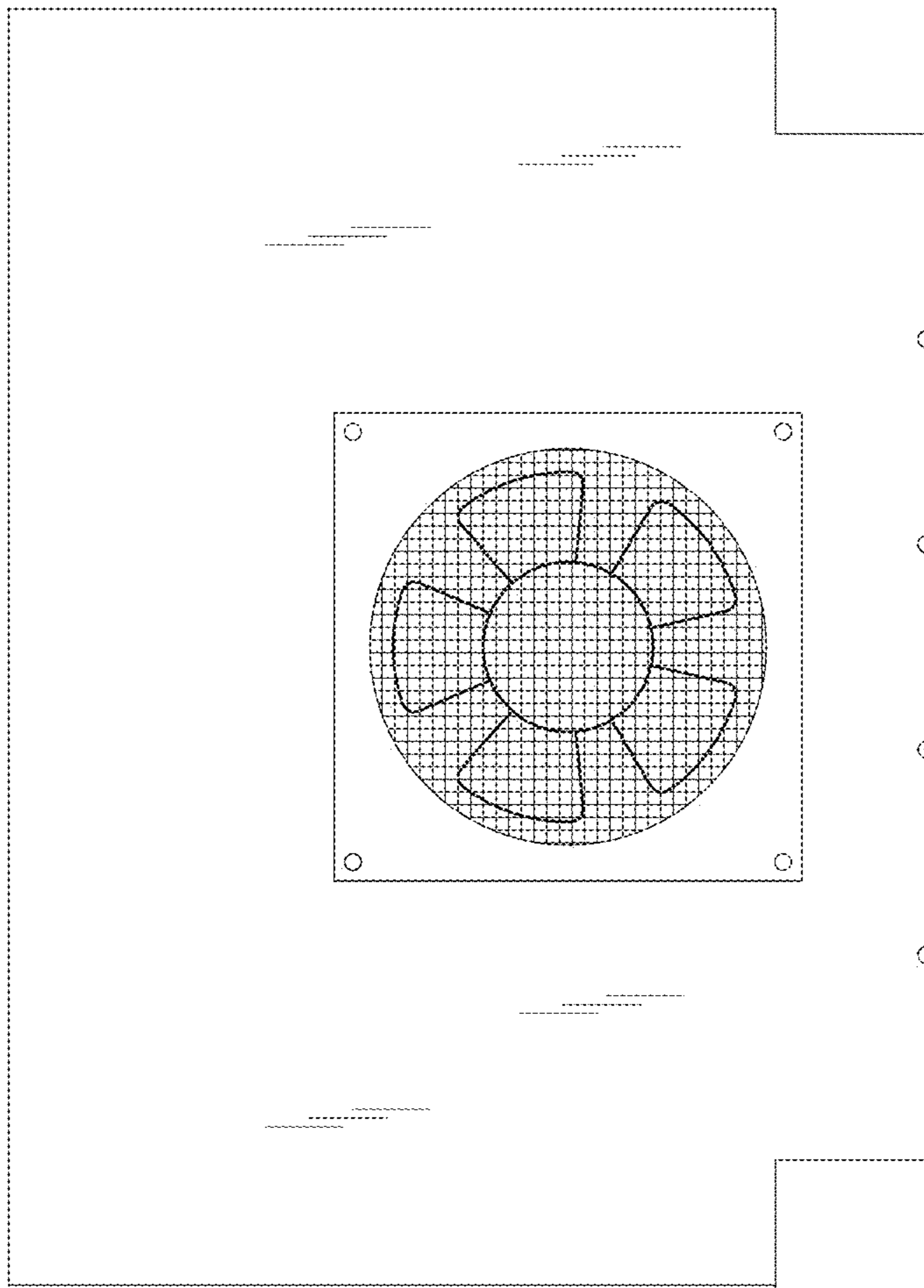

FIG. 17

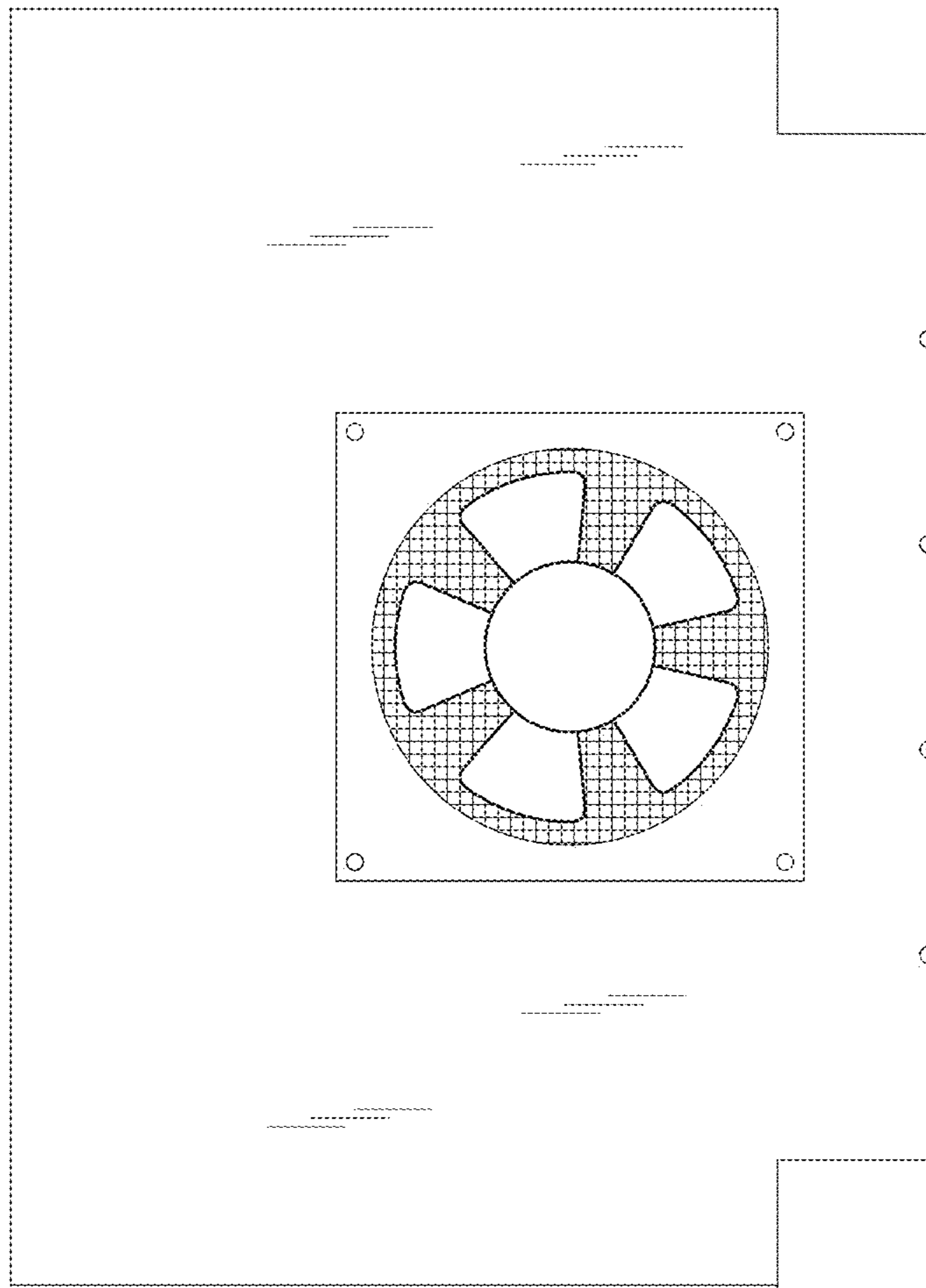

FIG. 18

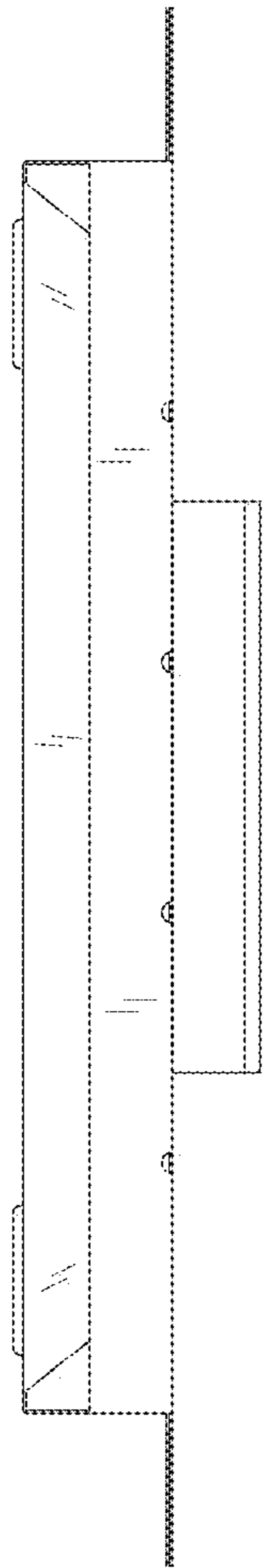

FIG. 19

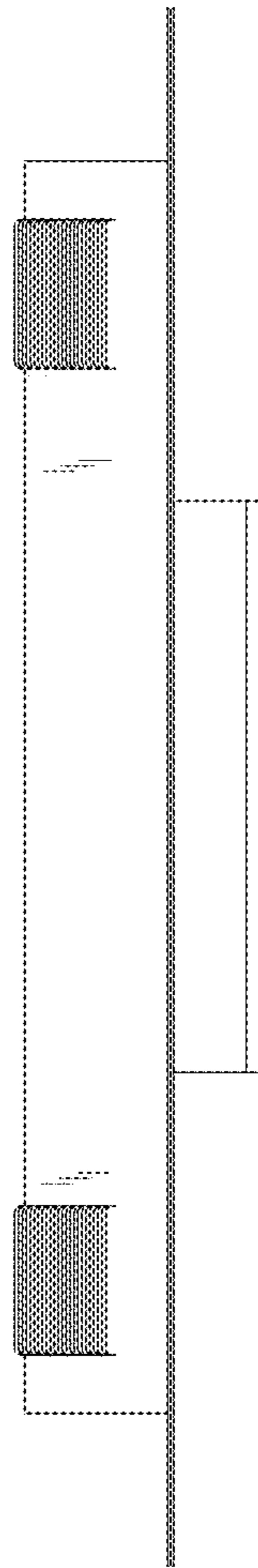

FIG. 20

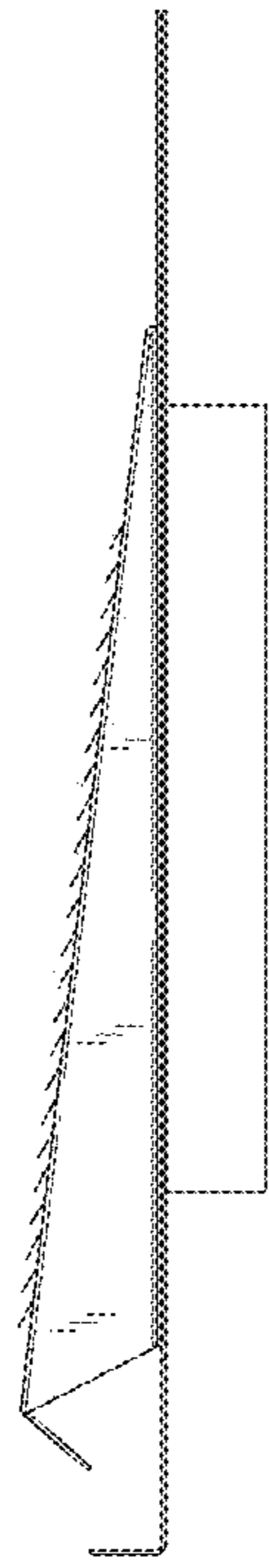

FIG. 21

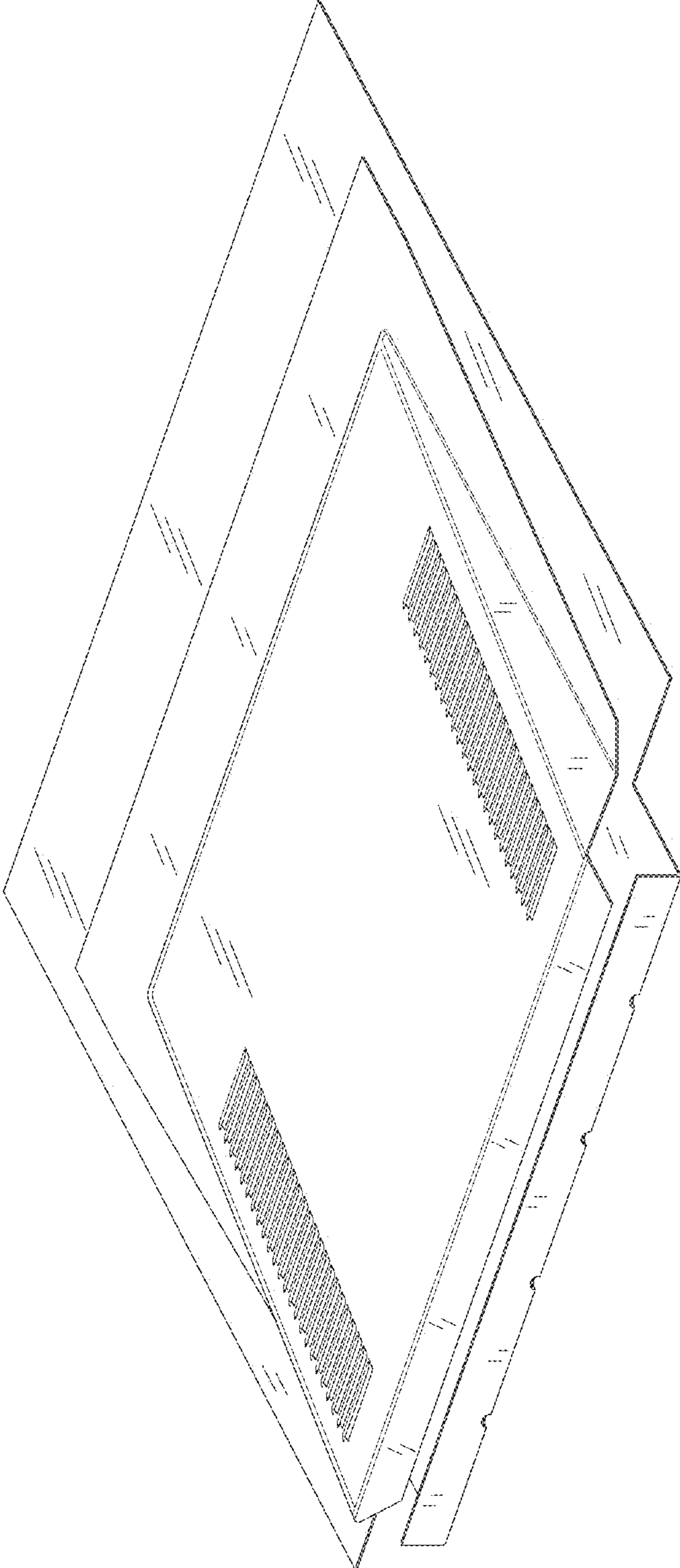

FIG. 22

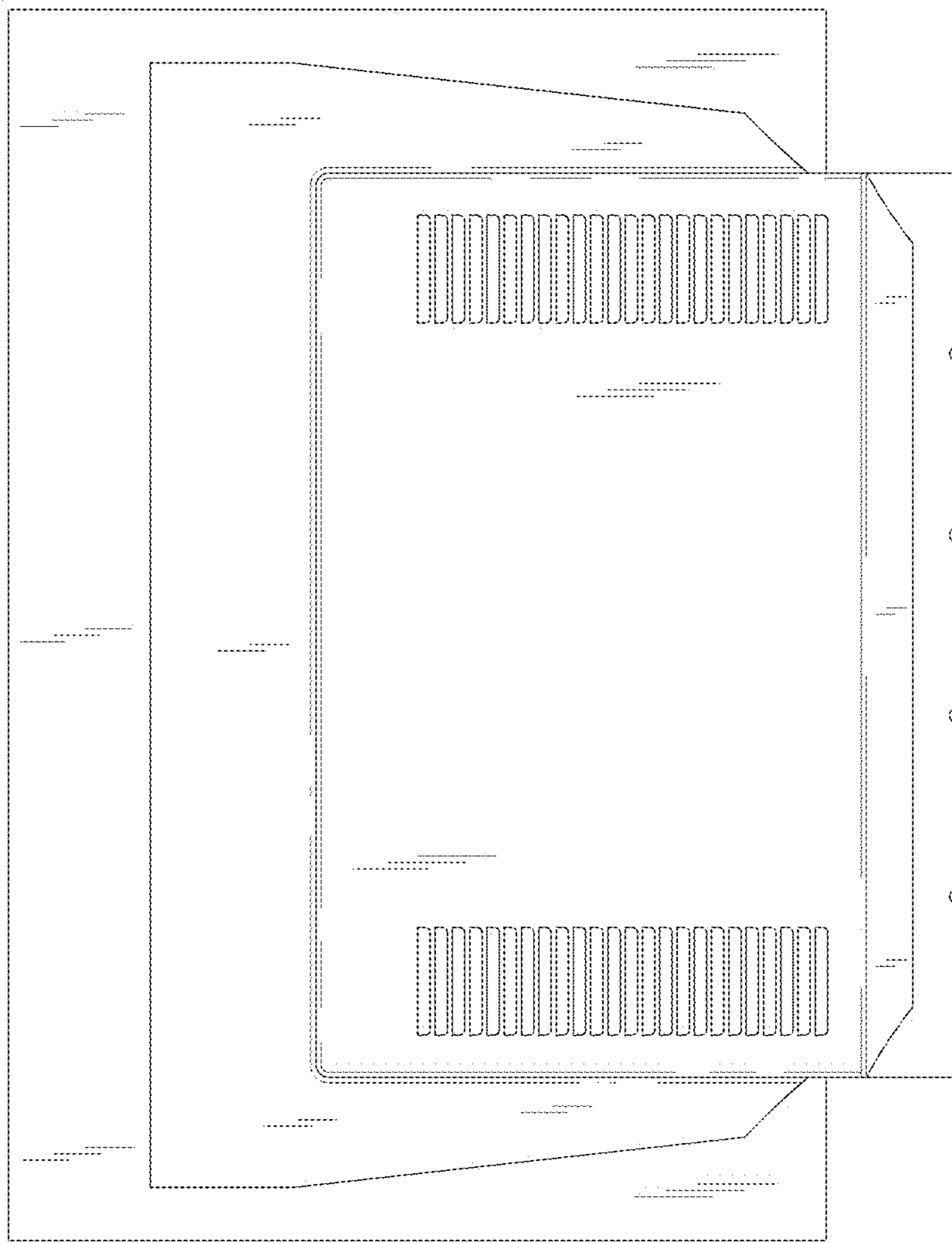

FIG. 23

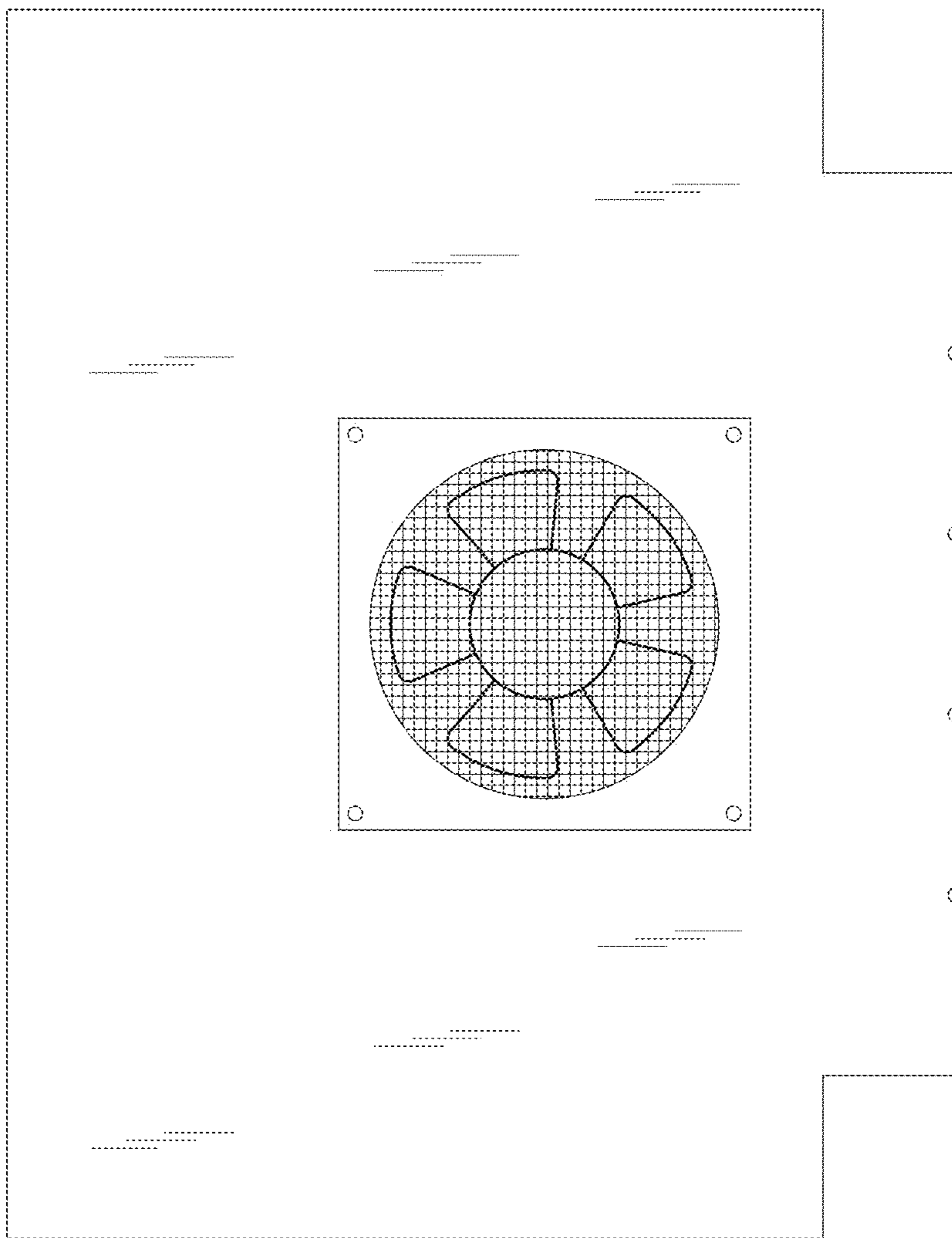

FIG. 24

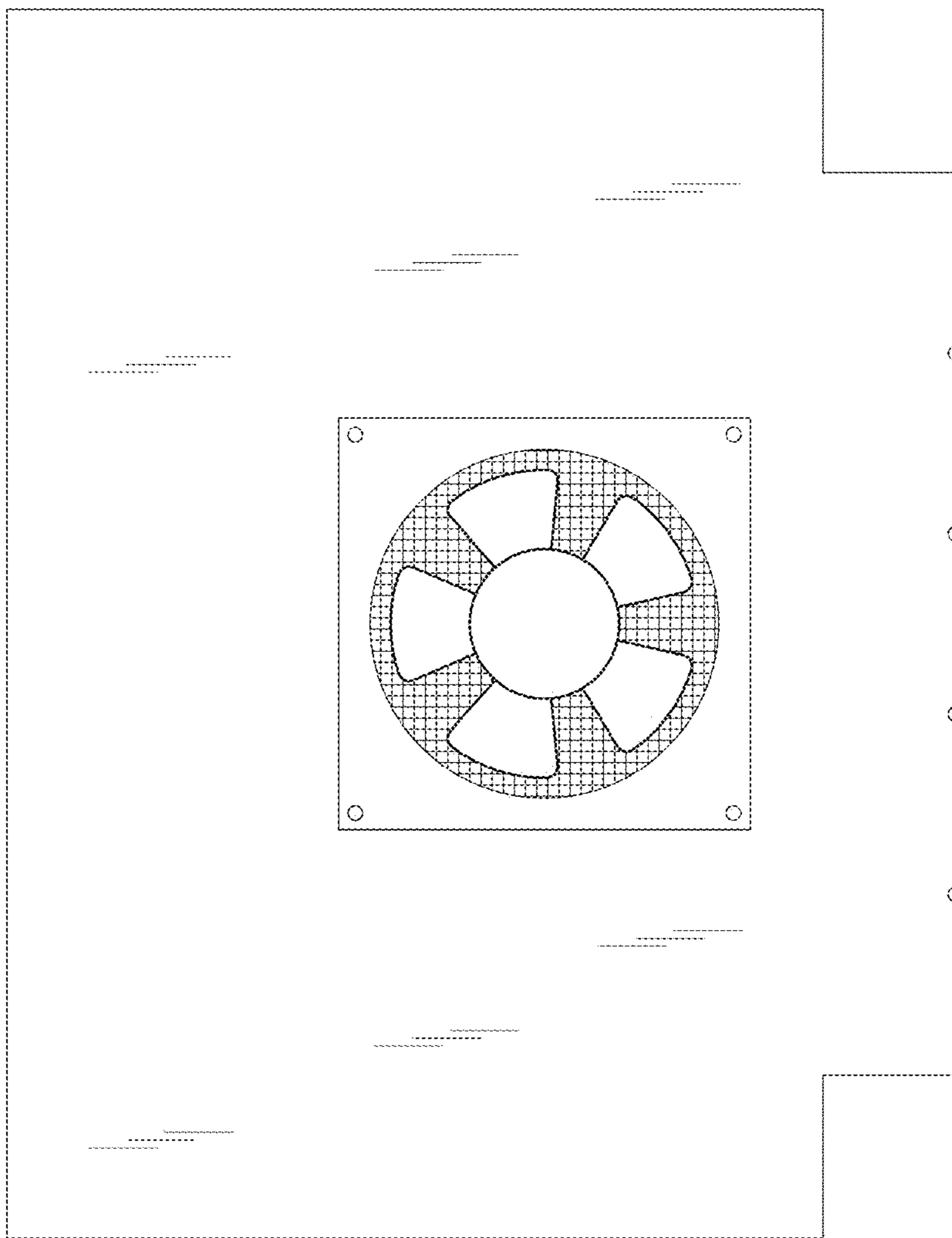

FIG. 25

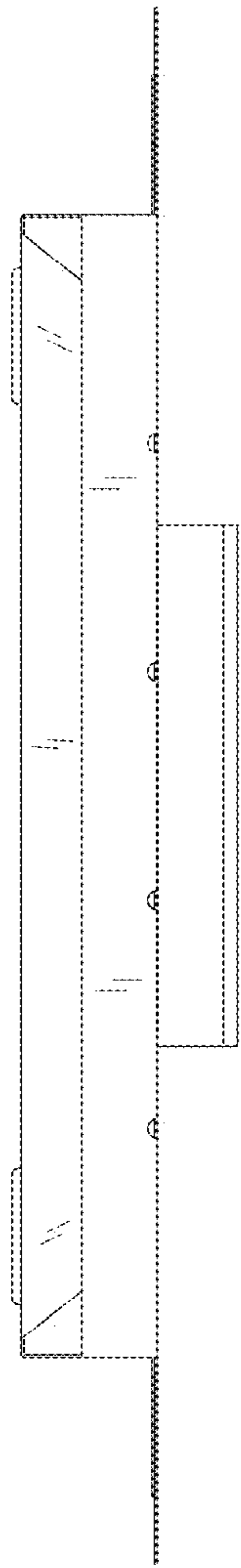

FIG. 26

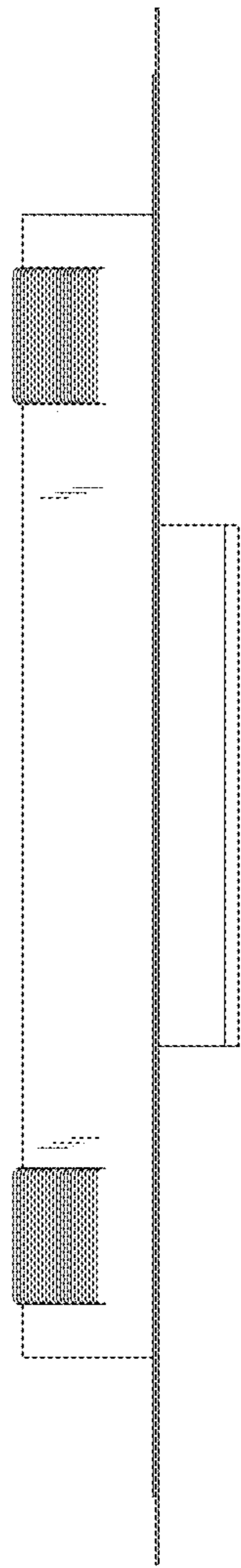

FIG. 27

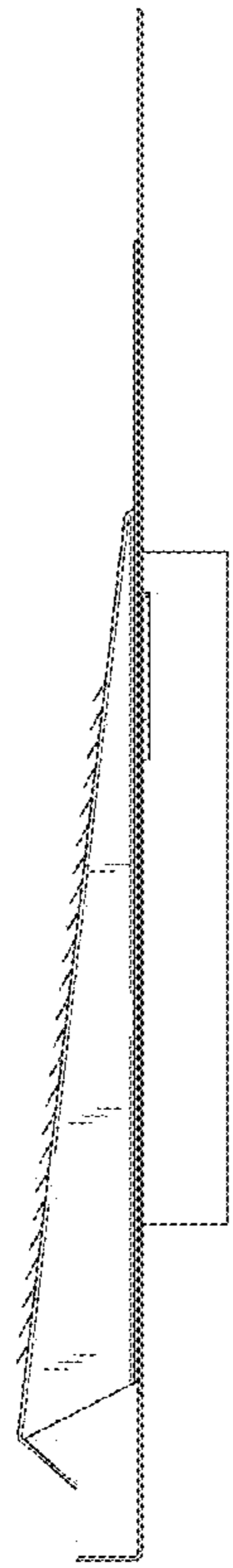

FIG. 28