



US00D891567S

(12) **United States Design Patent** (10) **Patent No.:** **US D891,567 S**
Burrow et al. (45) **Date of Patent:** **** Jul. 28, 2020**

(54) **AMMUNITION CARTRIDGE NOSE HAVING AN ANGLED SHOULDER**

676,000 A 6/1901 Henneberg
743,242 A 11/1903 Bush
865,979 A 9/1907 Bailey
869,046 A 10/1907 Bailey
905,358 A 12/1908 Peters
957,171 A 5/1910 Loeb
963,911 A 7/1910 Loeble

(71) Applicant: **True Velocity IP Holdings, LLC**,
Garland, TX (US)

(72) Inventors: **Lonnie Burrow**, Carrollton, TX (US);
Christopher William Overton, Wylie,
TX (US); **Nimmy Mammoottil**,
Richardson, TX (US); **Florian Herzog**,
Dallas, TX (US)

(Continued)

FOREIGN PATENT DOCUMENTS

(73) Assignee: **True Velocity IP Holdings, LLC**,
Garland, TX (US)

CA 2813634 A1 4/2012
CN 102901403 B 6/2014

(Continued)

OTHER PUBLICATIONS

(**) Term: **15 Years**

AccurateShooter.com Daily Bulletin "New PolyCase Ammunition and Injection-Molded Bullets" Jan. 11, 2015.

(21) Appl. No.: **29/683,244**

(22) Filed: **Mar. 12, 2019**

Primary Examiner — Michael A. Pratt

(51) **LOC (12) Cl.** **22-16**

(74) *Attorney, Agent, or Firm* — Chainey P. Singleton

(52) **U.S. Cl.** **D22/116**
USPC **D22/116**

(57) **CLAIM**

(58) **Field of Classification Search**
USPC D22/115-116
See application file for complete search history.

The ornamental design for an ammunition cartridge nose having an angled shoulder, as shown and described.

DESCRIPTION

(56) **References Cited**

U.S. PATENT DOCUMENTS

99,528 A 2/1870 Boyd
113,634 A 4/1871 Crispin
130,679 A 8/1872 Whitmore
159,665 A 2/1875 Gauthey
169,807 A 11/1875 Hart
207,248 A 8/1878 Bush et al.
462,611 A 11/1891 Comte de Sparre
475,008 A 5/1892 Bush
498,856 A 6/1893 Overbaugh
498,857 A 6/1893 Overbaugh
640,856 A 1/1900 Bailey
662,137 A 11/1900 Tellerson

FIG. 1 is an isometric view of an ammunition cartridge nose having an angled shoulder showing my new design of the nose portion of an ammunition cartridge.
FIG. 2 is a top view of my new design of the nose portion of an ammunition cartridge.
FIG. 3 is a cross sectional view along 3-3 of FIG. 2 showing my new design of the nose portion of an ammunition cartridge; and,
FIG. 4 is a cross sectional view along 4-4 of FIG. 2 showing my new design of the nose portion of an ammunition cartridge.

1 Claim, 4 Drawing Sheets

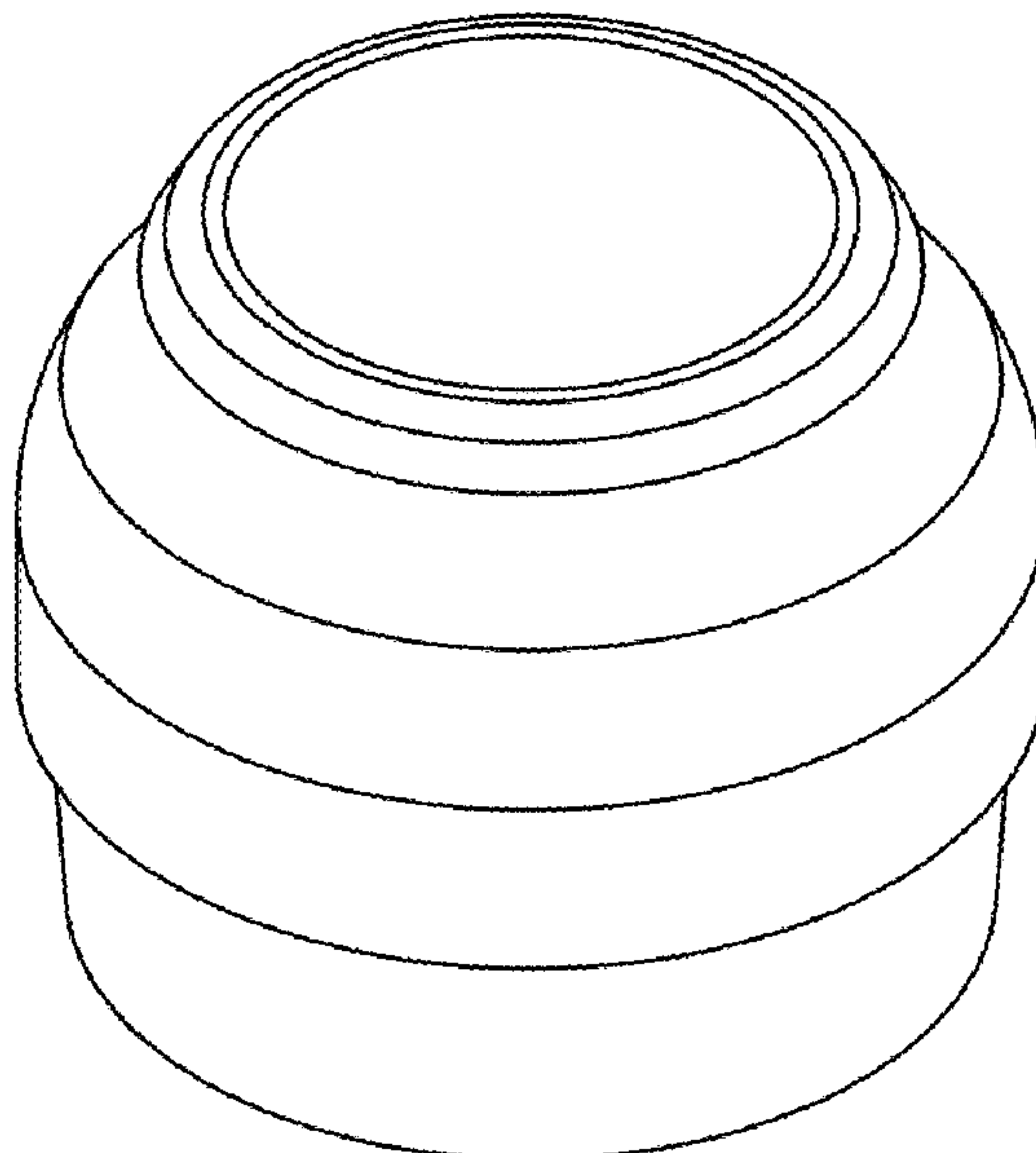

(56)

References Cited

U.S. PATENT DOCUMENTS

1,060,817 A	5/1913	Clyne	5,090,327 A	2/1992	Bilgeri
1,060,818 A	5/1913	Clyne	5,127,331 A	7/1992	Stoops
1,064,907 A	6/1913	Hoagland	5,151,555 A	9/1992	Vatsvog
1,187,464 A	6/1916	Offutt	5,165,040 A	11/1992	Andersson et al.
1,936,905 A	11/1933	Gaidos	5,237,930 A	8/1993	Belanger et al.
1,940,657 A	12/1933	Woodford	5,247,888 A	9/1993	Conil
2,294,822 A	9/1942	Norman	5,259,288 A	11/1993	Vatsvog
2,465,962 A	3/1949	Allen et al.	5,265,540 A	11/1993	Ducros et al.
2,654,319 A	10/1953	Roske	D345,676 S	4/1994	Biffle
2,823,611 A	2/1958	Thayer	5,433,148 A	7/1995	Barratault et al.
2,862,446 A	12/1958	Lars	5,535,495 A	7/1996	Gutowski
2,918,868 A	12/1959	Lars	5,563,365 A	10/1996	Dineen et al.
2,936,709 A	5/1960	Seavey	5,616,642 A	4/1997	West et al.
2,953,990 A	9/1960	Miller	D380,650 S	7/1997	Norris
2,972,947 A	2/1961	Fitzsimmons et al.	5,679,920 A	10/1997	Hallis et al.
3,034,433 A	5/1962	Karl	5,758,445 A	6/1998	Casull
3,099,958 A	8/1963	Daubenspeck et al.	5,770,815 A	6/1998	Watson
3,157,121 A	11/1964	Daubenspeck et al.	5,798,478 A	8/1998	Beal
3,159,701 A	12/1964	Herter	5,950,063 A	9/1999	Hens et al.
3,170,401 A	2/1965	Johnson et al.	5,961,200 A	10/1999	Friis
3,171,350 A	3/1965	Metcalf et al.	5,969,288 A	10/1999	Baud
3,242,789 A	3/1966	Woodring	5,979,331 A	11/1999	Casull
3,256,815 A	6/1966	Davidson et al.	6,004,682 A	12/1999	Rackovan et al.
3,288,066 A	11/1966	Hans et al.	6,048,379 A	4/2000	Bray et al.
3,292,538 A	12/1966	Hans et al.	6,070,532 A	6/2000	Halverson
3,332,352 A	7/1967	Olson et al.	D435,626 S	12/2000	Benini
3,444,777 A	5/1969	Lage	6,257,148 B1	7/2001	Toivonen et al.
3,446,146 A	5/1969	Stadler et al.	6,257,149 B1	7/2001	Cesaroni
3,485,170 A	12/1969	Scanlon	D447,209 S	8/2001	Benini
3,485,173 A	12/1969	Morgan	6,272,993 B1	8/2001	Cook et al.
3,491,691 A	1/1970	Vawter	6,283,035 B1	9/2001	Olson et al.
3,565,008 A	2/1971	Gulley et al.	6,357,357 B1	3/2002	Glasser
3,590,740 A	7/1971	Herter	D455,052 S	4/2002	Gullickson et al.
3,609,904 A	10/1971	Scanlon	D455,320 S	4/2002	Edelstein
3,614,929 A	10/1971	Herter et al.	6,375,971 B1	4/2002	Hansen
3,659,528 A	5/1972	Santala	6,408,764 B1	6/2002	Heitmann et al.
3,688,699 A	9/1972	Horn et al.	6,450,099 B1	9/2002	Desgland
3,690,256 A	9/1972	Schnitzer	6,460,464 B1	10/2002	Attarwala
3,745,924 A	7/1973	Scanlon	6,523,476 B1	2/2003	Riess et al.
3,749,021 A	7/1973	Burgess	6,644,204 B2	11/2003	Pierrot et al.
3,756,156 A	9/1973	Schuster	6,649,095 B2	11/2003	Buja
3,765,297 A	10/1973	Skochko et al.	6,672,219 B2	1/2004	Mackerell et al.
3,768,413 A	10/1973	Ramsay	6,708,621 B1	3/2004	Forichon-Chaumet et al.
3,797,396 A	3/1974	Reed	6,752,084 B1	6/2004	Husseini et al.
3,842,739 A	10/1974	Scanlon et al.	6,796,243 B2	9/2004	Schmees et al.
3,866,536 A	2/1975	Greenberg	6,810,816 B2	11/2004	Rennard
3,874,294 A	4/1975	Hale	6,840,149 B2	1/2005	Beal
3,955,506 A	5/1976	Luther et al.	6,845,716 B2	1/2005	Husseini et al.
3,977,326 A	8/1976	Anderson et al.	7,000,547 B2	2/2006	Amick
3,990,366 A	11/1976	Scanlon	7,014,284 B2	3/2006	Morton et al.
4,005,630 A	2/1977	Patrick	7,032,492 B2	4/2006	Meshirer
4,020,763 A	5/1977	Iruetagoyena	7,056,091 B2	6/2006	Powers
4,132,173 A	1/1979	Amuchastegui	7,059,234 B2	6/2006	Husseini
4,147,107 A	4/1979	Ringdal	7,165,496 B2	1/2007	Reynolds
4,157,684 A	6/1979	Clausser	D540,710 S	4/2007	Charrin
4,173,186 A	11/1979	Dunham	7,204,191 B2	4/2007	Wiley et al.
4,179,992 A	12/1979	Ramnarace et al.	7,213,519 B2	5/2007	Wiley et al.
4,187,271 A	2/1980	Rolston et al.	7,231,519 B2	6/2007	Joseph et al.
4,228,724 A	10/1980	Leich	7,232,473 B2	6/2007	Elliott
4,276,830 A	7/1981	Alice	7,299,750 B2	11/2007	Schikora et al.
4,353,304 A	10/1982	Hubsch et al.	7,353,756 B2	4/2008	Leasure
4,475,435 A	10/1984	Mantel	7,380,505 B1	6/2008	Shiery
4,483,251 A	11/1984	Spalding	7,383,776 B2	6/2008	Amick
4,598,445 A	7/1986	O'Connor	7,392,746 B2	7/2008	Hansen
4,614,157 A	9/1986	Grelle et al.	7,441,504 B2	10/2008	Husseini et al.
4,679,505 A	7/1987	Reed	D583,927 S	12/2008	Benner
4,718,348 A	1/1988	Ferrigno	7,458,322 B2	12/2008	Reynolds et al.
4,719,859 A	1/1988	Ballreich et al.	7,461,597 B2	12/2008	Brunn
4,726,296 A	2/1988	Leshner et al.	7,568,417 B1	8/2009	Lee
4,763,576 A	8/1988	Kass et al.	7,585,166 B2	9/2009	Buja
4,867,065 A	9/1989	Kaltmann et al.	7,610,858 B2	11/2009	Chung
4,970,959 A	11/1990	Bilsbury et al.	7,750,091 B2	7/2010	Maljkovic et al.
5,021,206 A	6/1991	Stoops	D626,619 S	11/2010	Gogol et al.
5,033,386 A	7/1991	Vatsvog	7,841,279 B2	11/2010	Reynolds et al.
5,063,853 A	11/1991	Bilgeri	D631,699 S	2/2011	Moreau
			D633,166 S	2/2011	Richardson et al.
			7,930,977 B2	4/2011	Klein
			8,007,370 B2	8/2011	Hirsch et al.
			8,056,232 B2	11/2011	Patel et al.

(56)

References Cited

U.S. PATENT DOCUMENTS							
8,156,870	B2	4/2012	South	D779,024	S	2/2017	Burrow
8,186,273	B2	5/2012	Trivette	D780,283	S	2/2017	Burrow
8,201,867	B2	6/2012	Thomeczek	9,587,918	B1	3/2017	Burrow
8,206,522	B2	6/2012	Sandstrom et al.	9,599,443	B2	3/2017	Padgett et al.
8,240,252	B2	8/2012	Maljkovic et al.	9,625,241	B2	4/2017	Neugebauer
D675,882	S	2/2013	Crockett	9,631,907	B2	4/2017	Burrow
8,408,137	B2	4/2013	Battaglia	9,644,930	B1	5/2017	Burrow
D683,419	S	5/2013	Rebar	9,658,042	B2	5/2017	Emary
8,443,729	B2	5/2013	Mittelstaedt	9,683,818	B2	6/2017	Lemke et al.
8,443,730	B2	5/2013	Padgett	D792,200	S	7/2017	Baiz et al.
8,511,233	B2	8/2013	Nilsson	9,709,368	B2	7/2017	Mahnke
D689,975	S	9/2013	Carlson et al.	D797,880	S	9/2017	Seecamp
8,522,684	B2	9/2013	Davies et al.	9,759,554	B2	9/2017	Ng et al.
8,540,828	B2	9/2013	Busky et al.	D800,244	S	10/2017	Burczynski et al.
8,561,543	B2	10/2013	Burrow	D800,245	S	10/2017	Burczynski et al.
8,573,126	B2	11/2013	Klein et al.	D800,246	S	10/2017	Burczynski et al.
8,641,842	B2	2/2014	Hafner et al.	9,784,667	B2	10/2017	Lukay et al.
8,689,696	B1	4/2014	Seeman et al.	9,835,423	B2	12/2017	Burrow
8,763,535	B2	7/2014	Padgett	9,835,427	B2	12/2017	Burrow
8,790,455	B2	7/2014	Borissov et al.	9,857,151	B2	1/2018	Dionne et al.
8,807,008	B2	8/2014	Padgett et al.	9,869,536	B2	1/2018	Burrow
8,813,650	B2	8/2014	Maljkovic et al.	9,879,954	B2	1/2018	Hajjar
D715,888	S	10/2014	Padgett	9,885,551	B2	2/2018	Burrow
8,850,985	B2	10/2014	Maljkovic et al.	D813,975	S	3/2018	White
8,857,343	B2	10/2014	Marx	9,921,040	B2	3/2018	Rubin
8,869,702	B2	10/2014	Padgett	9,927,219	B2	3/2018	Burrow
D717,909	S	11/2014	Thrift et al.	9,933,241	B2	4/2018	Burrow
8,875,633	B2	11/2014	Padgett	9,939,236	B2	4/2018	Drobockyi et al.
8,893,621	B1	11/2014	Escobar	9,964,388	B1	5/2018	Burrow
8,978,559	B2	3/2015	Davies et al.	D821,536	S	6/2018	Christiansen et al.
9,003,973	B1	4/2015	Padgett	9,989,339	B2	6/2018	Riess
9,032,855	B1	5/2015	Foren et al.	10,041,770	B2	8/2018	Burrow
9,091,516	B2	7/2015	Davies et al.	10,041,771	B1	8/2018	Burrow
9,103,641	B2	8/2015	Nielson et al.	10,041,776	B1	8/2018	Burrow
9,157,709	B2	10/2015	Nuetzman et al.	10,041,777	B1	8/2018	Burrow
9,170,080	B2	10/2015	Poore et al.	10,048,049	B2	8/2018	Burrow
9,182,204	B2	11/2015	Maljkovic et al.	10,048,050	B1	8/2018	Burrow
9,188,412	B2	11/2015	Maljkovic et al.	10,048,052	B2	8/2018	Burrow
9,200,157	B2	12/2015	El-Hibri et al.	10,054,413	B1	8/2018	Burrow
9,200,880	B1	12/2015	Foren et al.	D828,483	S	9/2018	Burrow
9,212,876	B1	12/2015	Kostka et al.	10,081,057	B2	9/2018	Burrow
9,212,879	B2	12/2015	Whitworth	D832,037	S	10/2018	Gallagher
9,213,175	B2	12/2015	Arnold	10,101,140	B2	10/2018	Burrow
9,254,503	B2	2/2016	Ward	10,124,343	B2	11/2018	Tsai
9,255,775	B1	2/2016	Rubin	10,145,662	B2	12/2018	Burrow
D752,397	S	3/2016	Seiders et al.	10,190,857	B2	1/2019	Burrow
D754,223	S	4/2016	Pederson et al.	10,234,249	B2	3/2019	Burrow
9,329,004	B2	5/2016	Pace	10,234,253	B2	3/2019	Burrow
9,335,137	B2	5/2016	Maljkovic et al.	10,240,905	B2	3/2019	Burrow
9,337,278	B1	5/2016	Gu et al.	10,254,096	B2	4/2019	Burrow
9,347,457	B2	5/2016	Ahrens et al.	10,260,847	B2	4/2019	Viggiano et al.
9,366,512	B2	6/2016	Burczynski et al.	D849,181	S	5/2019	Burrow
9,377,278	B2	6/2016	Rubin	10,302,403	B2	5/2019	Burrow
9,389,052	B2	7/2016	Conroy et al.	10,302,404	B2	5/2019	Burrow
9,395,165	B2	7/2016	Maljkovic et al.	10,330,451	B2	6/2019	Burrow
D764,624	S	8/2016	Masinelli	10,345,088	B2	7/2019	Burrow
D765,214	S	8/2016	Padgett	10,352,664	B2	7/2019	Burrow
9,429,407	B2	8/2016	Burrow	10,352,670	B2	7/2019	Burrow
9,441,930	B2	9/2016	Burrow	10,359,262	B2	7/2019	Burrow
9,453,714	B2	9/2016	Bosarge et al.	10,365,074	B2	7/2019	Burrow
D773,009	S	11/2016	Bowers	D861,118	S	9/2019	Burrow
9,500,453	B2	11/2016	Schluckebier et al.	D861,119	S	9/2019	Burrow
9,506,735	B1	11/2016	Burrow	10,408,582	B2	9/2019	Burrow
D774,824	S	12/2016	Gallagher	10,408,592	B2	9/2019	Boss et al.
9,513,096	B2	12/2016	Burrow	10,415,943	B2	9/2019	Burrow
9,518,810	B1	12/2016	Burrow	10,429,156	B2	10/2019	Burrow
9,523,563	B1	12/2016	Burrow	10,458,762	B2	10/2019	Burrow
9,528,799	B2	12/2016	Maljkovic	10,466,020	B2	11/2019	Burrow
9,546,849	B2	1/2017	Burrow	10,466,021	B2	11/2019	Burrow
9,551,557	B1	1/2017	Burrow	10,480,911	B2	11/2019	Burrow
D778,391	S	2/2017	Burrow	10,480,912	B2	11/2019	Burrow
D778,393	S	2/2017	Burrow	10,480,915	B2	11/2019	Burrow et al.
D778,394	S	2/2017	Burrow	10,488,165	B2	11/2019	Burrow
D778,395	S	2/2017	Burrow	10,533,830	B2	1/2020	Burrow et al.
D779,021	S	2/2017	Burrow	2003/0127011	A1	7/2003	Mackerell et al.
				2003/0131751	A1	7/2003	Mackerell et al.
				2004/0074412	A1	4/2004	Kightlinger
				2004/0200340	A1	10/2004	Robinson et al.
				2005/0056183	A1	3/2005	Meshirer

(56)

References Cited

U.S. PATENT DOCUMENTS

2005/0081704	A1	4/2005	Husseini	2017/0089679	A1	3/2017	Burrow
2005/0257712	A1	11/2005	Husseini et al.	2017/0115105	A1	4/2017	Burrow
2006/0027125	A1	2/2006	Brunn	2017/0153093	A9	6/2017	Burrow
2006/0260500	A1	11/2006	Engel et al.	2017/0153099	A9	6/2017	Burrow
2006/0278116	A1	12/2006	Hunt	2017/0191812	A1	7/2017	Padgett et al.
2006/0283345	A1	12/2006	Feldman et al.	2017/0199018	A9	7/2017	Burrow
2007/0056343	A1	3/2007	Cremonesi	2017/0205217	A9	7/2017	Burrow
2007/0181029	A1	8/2007	Mcaninch	2017/0261294	A1	9/2017	Riess
2007/0214992	A1	9/2007	Dittrich	2017/0261296	A1	9/2017	Burrow
2007/0214993	A1	9/2007	Cerovic et al.	2017/0299352	A9	10/2017	Burrow
2007/0267587	A1	11/2007	Dalluge	2018/0066925	A1	3/2018	Skowron et al.
2009/0314178	A1	12/2009	South	2018/0106581	A1	4/2018	Rogers
2010/0101444	A1	4/2010	Schluckebier et al.	2018/0224252	A1	8/2018	O'Rourke
2010/0212533	A1	8/2010	Brunn	2018/0224253	A1	8/2018	Burrow
2010/0234132	A1	9/2010	Hirsch et al.	2018/0224256	A1	8/2018	Burrow
2010/0258023	A1	10/2010	Reynolds et al.	2018/0259310	A1	9/2018	Burrow
2010/0275804	A1	11/2010	Trivette	2018/0292186	A1	10/2018	Padgett et al.
2010/0282112	A1	11/2010	Battaglia	2018/0306558	A1	10/2018	Padgett et al.
2011/0179965	A1	7/2011	Mason	2018/0321023	A1*	11/2018	Teig F42B 12/02
2012/0024183	A1	2/2012	Klein	2019/0011232	A1*	1/2019	Boss F42C 19/0807
2012/0037029	A1	2/2012	Klement	2019/0011233	A1	1/2019	Boss et al.
2012/0111219	A1	5/2012	Burrow	2019/0011234	A1	1/2019	Boss et al.
2012/0180685	A1	7/2012	Se-Hong	2019/0011235	A1	1/2019	Boss et al.
2012/0180687	A1	7/2012	Padgett et al.	2019/0011236	A1	1/2019	Burrow
2012/0180688	A1*	7/2012	Padgett F42B 5/313	2019/0011237	A1	1/2019	Burrow
			102/466	2019/0011238	A1	1/2019	Burrow
2012/0199033	A1	8/2012	Bybee et al.	2019/0011239	A1	1/2019	Burrow
2012/0291655	A1	11/2012	Jones	2019/0011240	A1	1/2019	Burrow
2013/0008335	A1	1/2013	Menefee	2019/0011241	A1	1/2019	Burrow
2013/0014664	A1*	1/2013	Padgett F42B 5/313	2019/0025019	A1	1/2019	Burrow
			102/439	2019/0025020	A1	1/2019	Burrow
2013/0014665	A1	1/2013	Maljkovic et al.	2019/0025021	A1	1/2019	Burrow
2013/0076865	A1	3/2013	Tateno et al.	2019/0025022	A1	1/2019	Burrow
2013/0186294	A1	7/2013	Davies et al.	2019/0025023	A1	1/2019	Burrow
2013/0291711	A1	11/2013	Mason	2019/0025024	A1	1/2019	Burrow
2014/0060372	A1	3/2014	Padgett	2019/0025025	A1	1/2019	Burrow
2014/0224144	A1	8/2014	Neugebauer	2019/0025026	A1	1/2019	Burrow
2014/0260925	A1	9/2014	Beach et al.	2019/0025035	A1	1/2019	Burrow
2014/0261044	A1	9/2014	Seecamp	2019/0025036	A1	1/2019	Burrow
2014/0311332	A1	10/2014	Carlson et al.	2019/0078862	A1	3/2019	Burrow
2015/0033970	A1	2/2015	Maljkovic et al.	2019/0106364	A1	4/2019	James
2015/0075400	A1	3/2015	Lemke et al.	2019/0107375	A1	4/2019	Burrow
2015/0226220	A1	8/2015	Bevington	2019/0137228	A1	5/2019	Burrow et al.
2015/0241183	A1	8/2015	Padgett et al.	2019/0137229	A1	5/2019	Burrow et al.
2015/0268020	A1	9/2015	Emary	2019/0137230	A1	5/2019	Burrow et al.
2016/0003585	A1	1/2016	Carpenter et al.	2019/0137231	A1	5/2019	Burrow et al.
2016/0003588	A1*	1/2016	Burrow C22C 33/0257	2019/0137232	A1	5/2019	Burrow et al.
			102/466	2019/0137233	A1	5/2019	Burrow et al.
2016/0003589	A1	1/2016	Burrow	2019/0137234	A1	5/2019	Burrow et al.
2016/0003590	A1	1/2016	Burrow	2019/0137235	A1	5/2019	Burrow et al.
2016/0003593	A1	1/2016	Burrow	2019/0137236	A1	5/2019	Burrow et al.
2016/0003594	A1	1/2016	Burrow	2019/0137237	A1	5/2019	Burrow et al.
2016/0003595	A1	1/2016	Burrow	2019/0137238	A1	5/2019	Burrow et al.
2016/0003596	A1	1/2016	Burrow	2019/0137239	A1	5/2019	Burrow et al.
2016/0003597	A1	1/2016	Burrow	2019/0137240	A1	5/2019	Burrow et al.
2016/0003601	A1	1/2016	Burrow	2019/0137241	A1	5/2019	Burrow et al.
2016/0033241	A1	2/2016	Burrow	2019/0137242	A1	5/2019	Burrow et al.
2016/0102030	A1	4/2016	Coffey et al.	2019/0137243	A1	5/2019	Burrow et al.
2016/0146585	A1	5/2016	Padgett	2019/0137244	A1	5/2019	Burrow et al.
2016/0209186	A1	7/2016	Hajjar	2019/0170488	A1	6/2019	Burrow
2016/0245626	A1	8/2016	Drieling et al.	2019/0204050	A1	7/2019	Burrow
2016/0265886	A1	9/2016	Aldrich et al.	2019/0204056	A1	7/2019	Burrow
2016/0349022	A1*	12/2016	Burrow F42B 5/307	2019/0212117	A1	7/2019	Burrow
2016/0349023	A1	12/2016	Burrow	2019/0242679	A1	8/2019	Viggiano et al.
2016/0349028	A1	12/2016	Burrow	2019/0242682	A1	8/2019	Burrow
2016/0356588	A1	12/2016	Burrow	2019/0242683	A1	8/2019	Burrow
2016/0377399	A1	12/2016	Burrow	2019/0249967	A1	8/2019	Burrow et al.
2017/0030690	A1	2/2017	Viggiano et al.	2019/0257625	A1	8/2019	Burrow
2017/0030692	A1	2/2017	Drobockyi et al.	2019/0310058	A1	10/2019	Burrow
2017/0080498	A1	3/2017	Burrow	2019/0310059	A1	10/2019	Burrow
2017/0082409	A1	3/2017	Burrow	2019/0316886	A1	10/2019	Burrow
2017/0082411	A1	3/2017	Burrow	2019/0360788	A1	11/2019	Burrow
2017/0089673	A1	3/2017	Burrow	2019/0376773	A1	12/2019	Burrow
2017/0089674	A1	3/2017	Burrow	2019/0376774	A1	12/2019	Boss et al.
2017/0089675	A1	3/2017	Burrow	2019/0383590	A1	12/2019	Burrow
				2020/0011645	A1	1/2020	Burrow et al.
				2020/0011646	A1	1/2020	Burrow et al.

(56)

References Cited

U.S. PATENT DOCUMENTS

2020/0025536 A1 1/2020 Burrow et al.
2020/0025537 A1 1/2020 Burrow et al.

FOREIGN PATENT DOCUMENTS

DE 16742 C 1/1882
EP 2625486 A4 8/2017
FR 1412414 A 10/1965
GB 783023 A 9/1957

RU 2172467 C1 8/2001
WO 0034732 6/2000
WO 2007014024 A2 2/2007
WO 2012047615 A1 4/2012
WO 2012097320 A1 7/2012
WO 2012097317 A3 11/2012
WO 2013070250 A1 5/2013
WO 2013096848 A1 6/2013
WO 2014062256 A2 4/2014
WO 2016003817 A1 1/2016
WO 2019094544 A1 5/2019
WO 2019160742 A2 8/2019

* cited by examiner

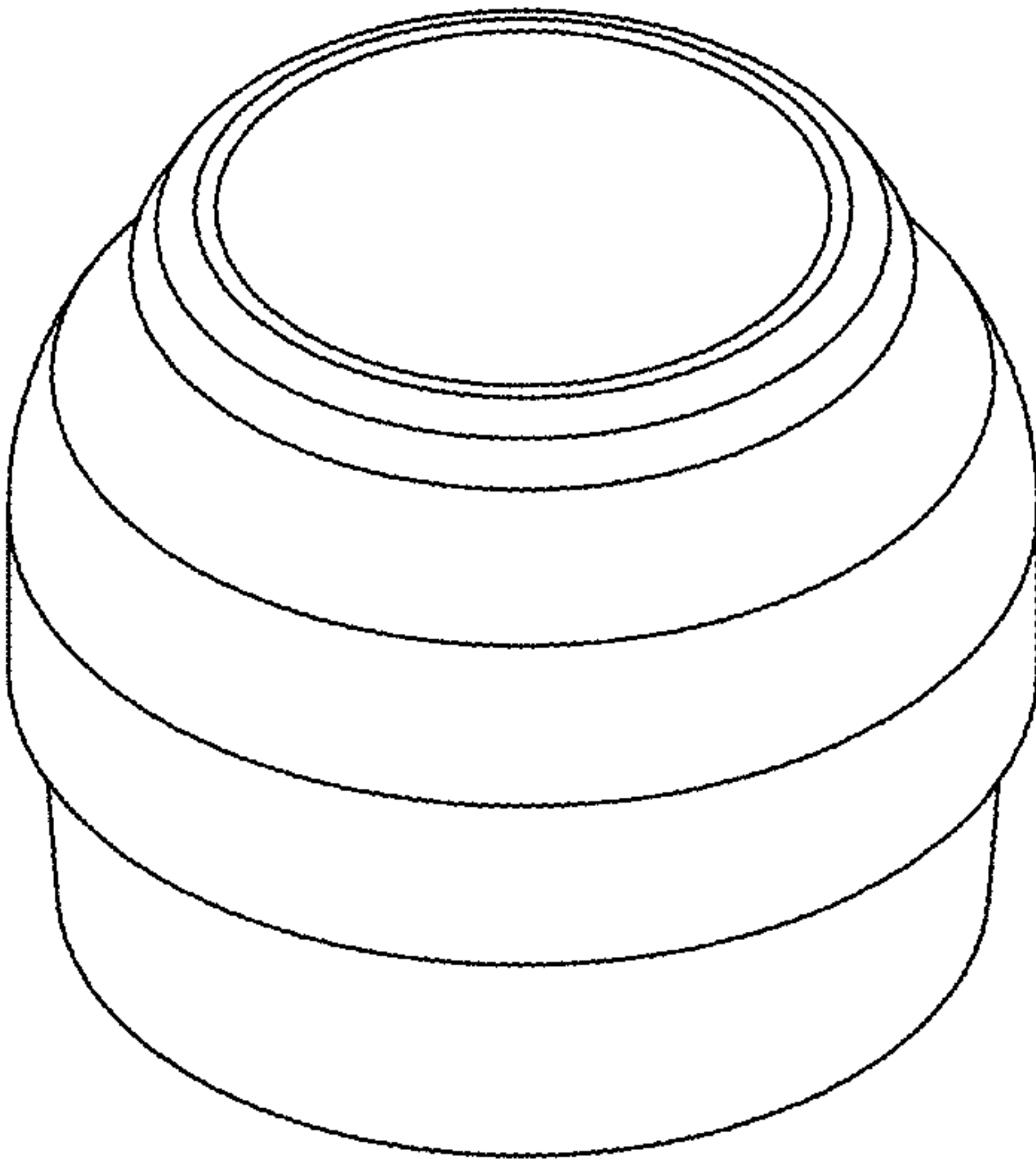

FIG. 1

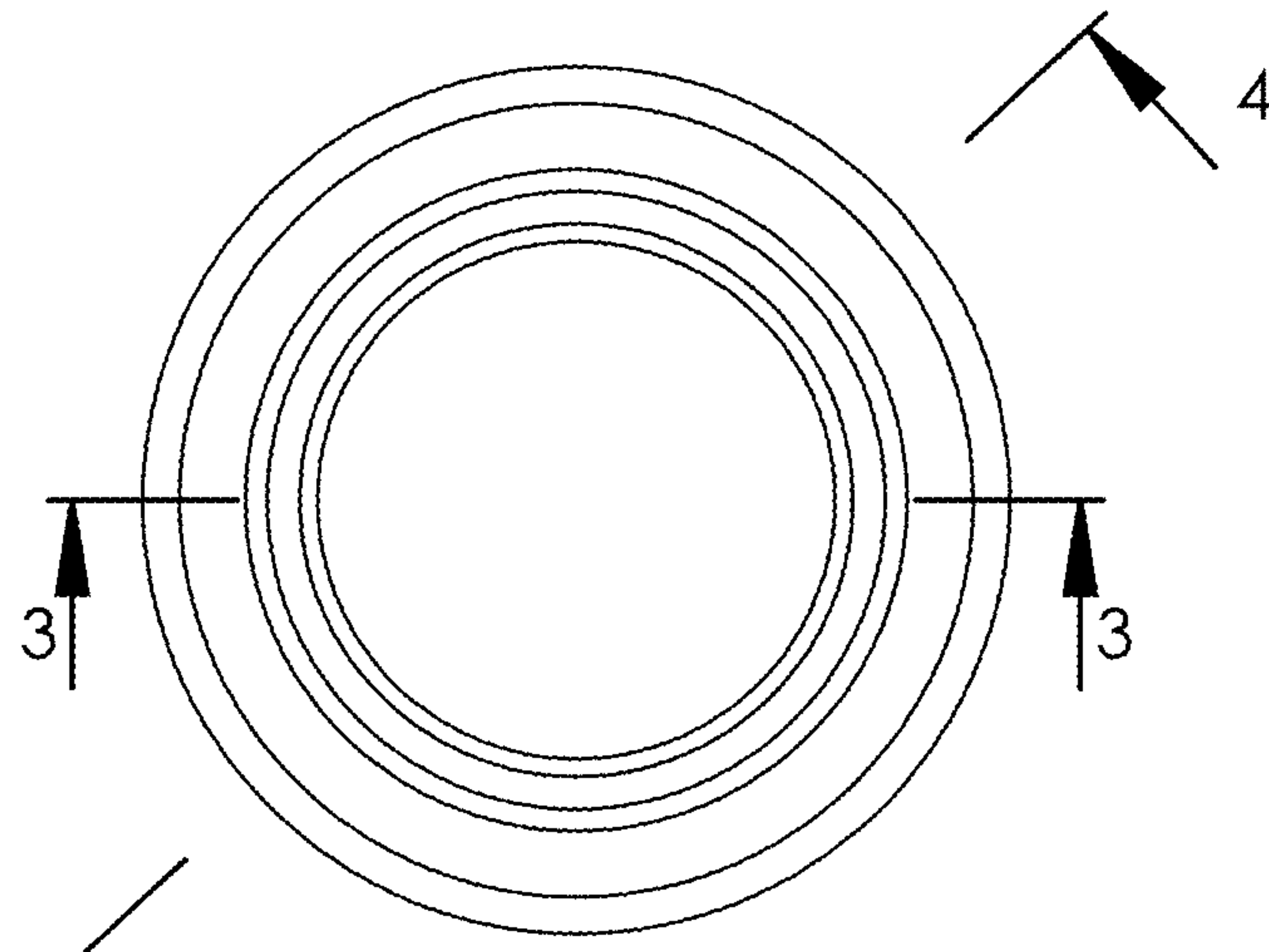

FIG. 2

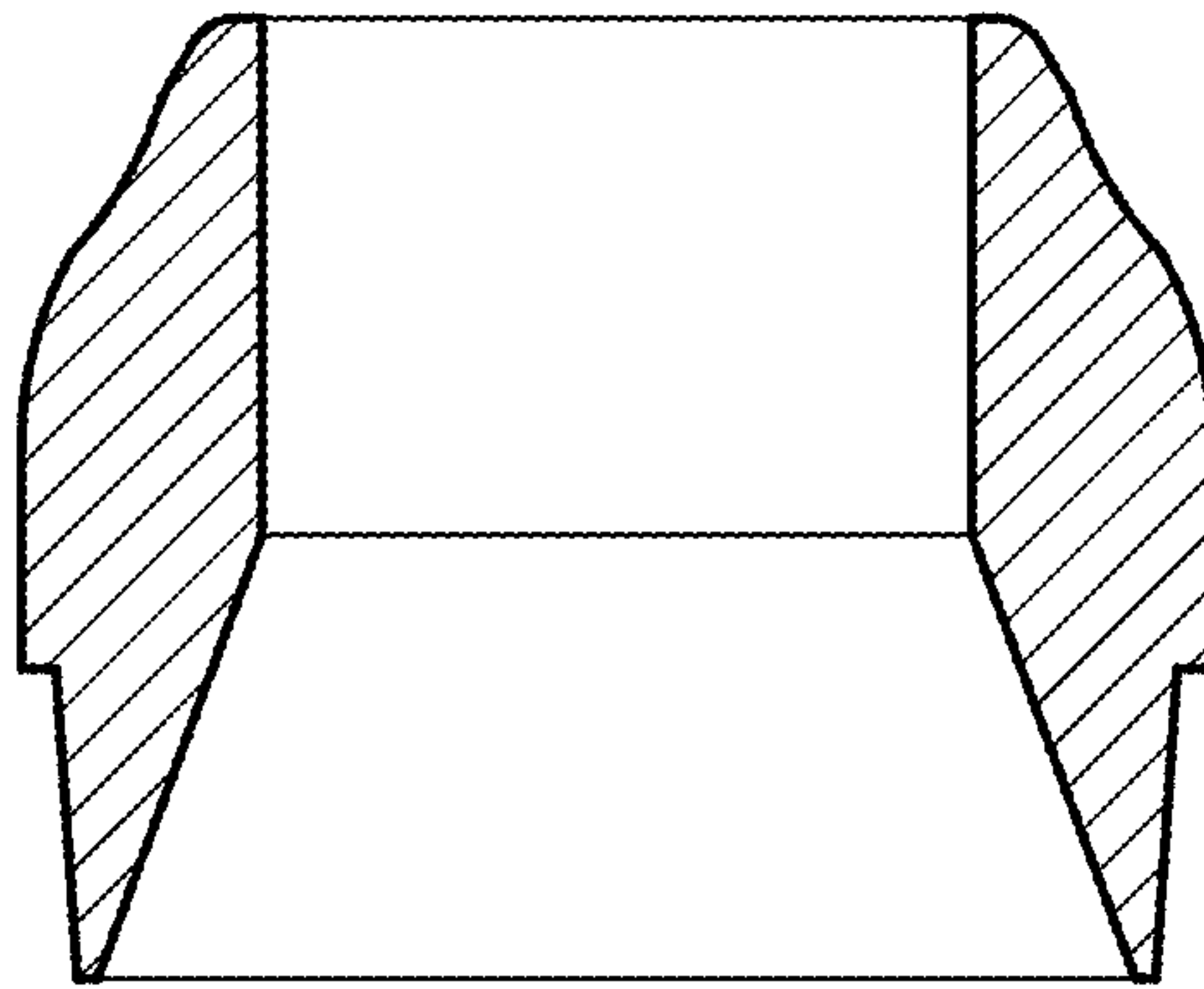

FIG. 3

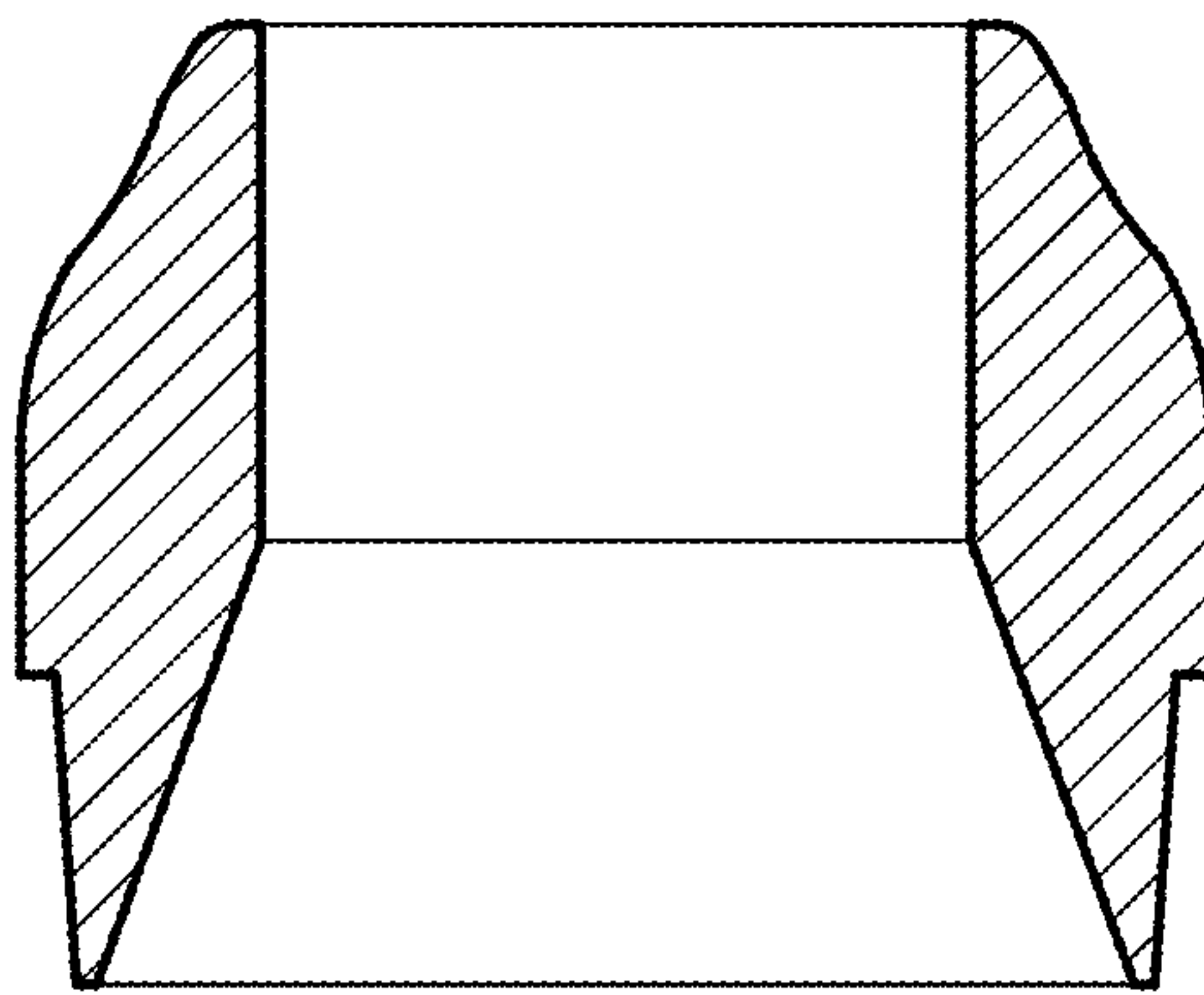

FIG. 4